

Top View of Assembly

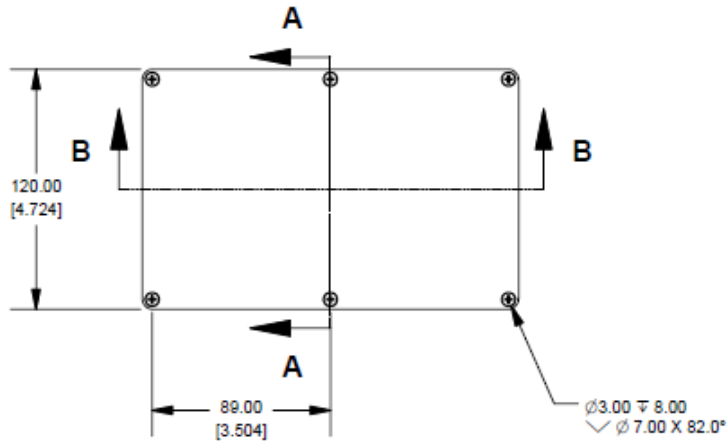

**SECTION A-A
End View of Assembly**

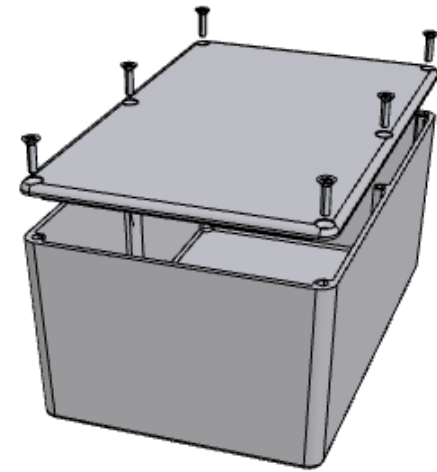
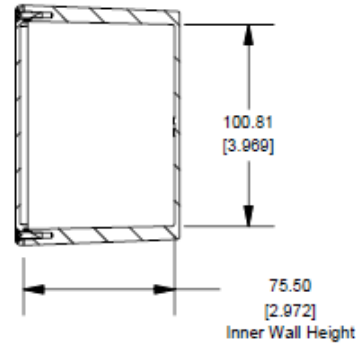

**SECTION B-B
Side View of Assembly**

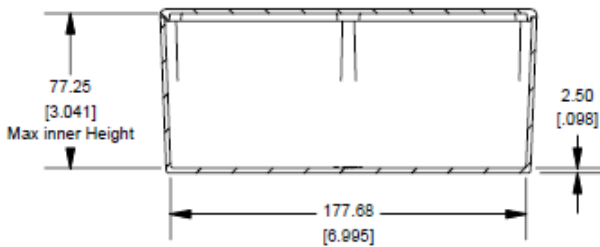

Top View Looking Inside Box

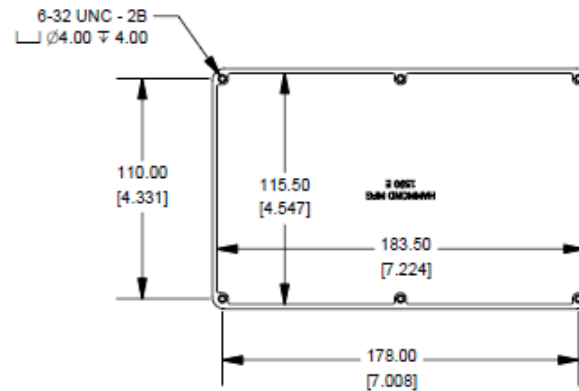

Lid

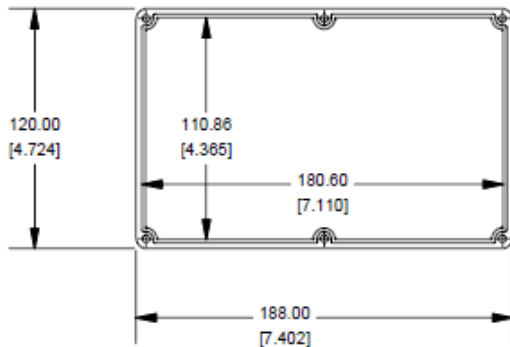

NOTE

Purchased assembly includes box, lid and 6 cover screws.
Box and lid are made from Diecast Aluminum Alloy (alloy type 380).
Silicone Gasket Loctite #5950

PART NUMBERS

1590E Enclosure	
Unfinished	1590E
Grey Textured Polyester Powder Paint - RAL 7038	1590EGY
Black Textured Polyester Powder Paint - RAL 9011	1590EBK
1590E Liquid Resistant Enclosure (Silicon Factory Installed Gasket)	
Unfinished	1590WE
Black Textured Powder Paint	1590WEBK
ACCESSORIES	
Recommended Torque: 75 ozf.in / 55 cN.m	
Black Textured Cover Screws (Pkg 50) [6-32 x 1/2" SS Type 304]	1590WMS100BK
Unfinished Cover Screws (Pkg 100) [6-32 x 1/2" Nickel Plated Screws]	1590WMS100
Standard Cover Screws	
Unfinished Cover Screws (Pkg 100) [6-32 x 1/2" Nickel Plated Screws]	1590MS100
Black Textured Cover Screws (Pkg 50) [6-32 x 1/2" SS Type 304]	1590MS100BK