

AUXILIARY WORKBENCH

A32 & A37 SERIES ASSEMBLY INSTRUCTIONS

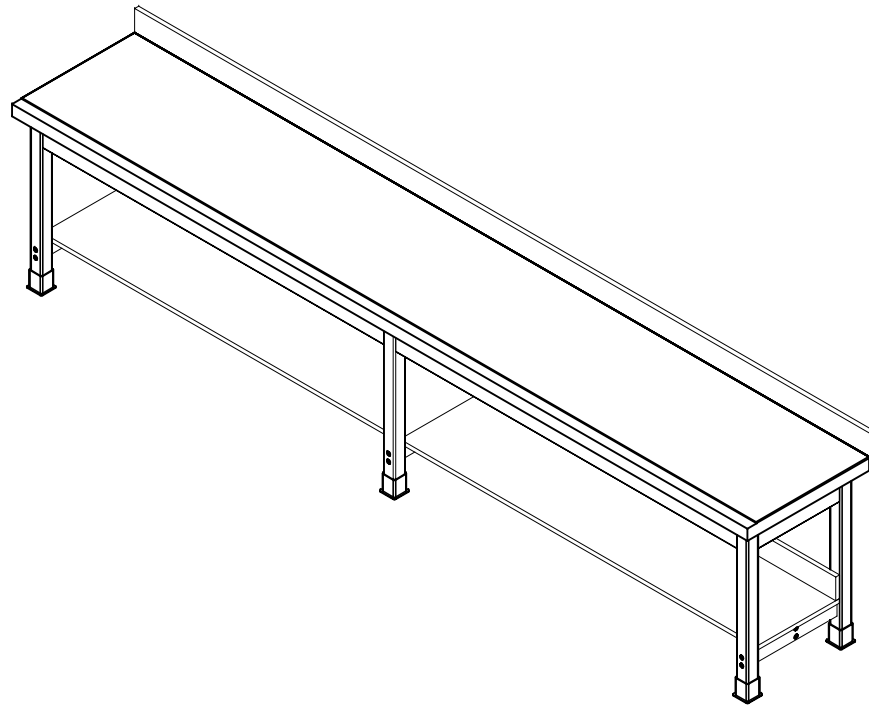

NOTE:

1. MODEL VIEWS MAY NOT REPRESENT EXACT MODEL PURCHASED

DWN BY:	EMK	DWN DATE:	9/11/14
APR BY:		DATE APR:	
APR BY:		DATE APR:	

UNLESS OTHERWISE SPECIFIED
DIMENSION ARE IN INCHES
CABINET SQUARENESS ± .0625
FRACTIONAL VALUES ± 1/32"
- ALL VALUES ± OVERALL -



300 South Krueger Street
Suring, WI 54174
diversifiedwoodcrafts.com

TITLE:
**AUXILIARY WORKBENCH
ASSEMBLY INSTRUCTIONS**

REV.	DESCRIPTION	DATE	NAME	ECH NO.
A	CREATED ASSEMBLY INSTRUCTIONS	9/11/14	EMK	-
REVISION LEVEL				

THIS DRAWING IS THE SOLE PROPERTY OF
DIVERSIFIED WOOD CRAFTS. IT MAY NOT
BE ALTERED OR CHANGED WITHOUT
PERMISSION

DRAWING NUMBER:	SCALE:	SHEET:	REVISION:
A32 & A37 SERIES	NTS	1 OF 6	REV A

TOOLS REQUIRED

1/2" WRENCH
1/2" SOCKET AND TORQUE WRENCH - OPTIONAL
4MM ALLEN WRENCH
PHILLIPS SCREW DRIVER
1/8" DRILL BIT

ASSEMBLY COMPONENTS

ITEMS INCLUDED	PART #	PART DESCRIPTION	QTY
TOP AND APRON ASSEMBLY	N/A	TOP ASSEMBLY (FACTORY ASSEMBLED)	1
TOP BACKSPLASH	236938	BACKSPLASH,MPL - SIZE VARIES WITH TABLE STYLE	1
LEGS	VARIES	LEG,MPL 2.25X2.25X HEIGHT VARIES	4 OR 6
LEG LEVELERS	100079	LEG LEVELER,BLK BASE 1	4 OR 6
LEG BOOT	100076	LEG BOOT,BLK RUBBER	4 OR 6
WASHER - CORNER LEG BRACKET	100039	WASHER,SPLIT LOCK 5/16	4
HEX NUT - CORNER LEG BRACKET	100044	NUT,HEX 5/16-18 STEEL ZINC	4
LEG BRACE	N/A	LEG BRACE - 16.00" LONG	2 OR 3
STRETCHER	N/A	STRETCHER - SIZE VARIES WITH TABLE STYLE	1 OR 2
CONFRIMATS - LEGS	227578	SCREW,7MMX90MM,CONN,ALLENHEAD, BLACK	8 OR 12
CONFIRMATS - STRETCHER	228564	SCREW,7MMX50MM,CONN,ALLENHEAD, BLACK	4
SHELF	N/A	SHELF - SIZE VARIES WITH TABLE STYLE	1 OR 2
SHELF BACKSPLASH	N/A	BACKSPLASH - SIZE VARIES WITH TABLE STYLE	1 OR 2
SCREWS - SHELF AND BACKSPLASH	100597	SCREW,#8X1.5 QUAD ROUND WASHER	VARIES
STRETCHER BRACKET	100525	BRACKET,RAIL 1.5X 1.5X .125,1.885L	2
SCREWS-STRETCHER BRACKET	100649	SCREW,#8X3/4 PHIL TRUSS HEAD SMS	8

NOTE:

1. ****XX**** INDICATES ITEMS ONLY USED FOR THE A32-10W, A32-12W, A37-10W, AND A37-12W.
2. QUANTITIES VARY WITH CHOICE OF TABLE STYLE.
3. A32 = 31 1/4" H, A37 = 37 1/4" H

DWN BY:	EMK	DWN DATE:	9/11/14
APR BY:		DATE APR:	
APR BY:		DATE APR:	

UNLESS OTHERWISE SPECIFIED
DIMENSION ARE IN INCHES
CABINET SQUARENESS ± .0625
FRACTIONAL VALUES ± 1/32"
- ALL VALUES ± OVERALL -



300 South Krueger Street
Suring, WI 54174
diversifiedwoodcrafts.com

TITLE:
**AUXILIARY WORKBENCH
TOOLS AND ASSEMBLY COMPONENTS**

REV.	DESCRIPTION	DATE	NAME	ECH NO.
A	CREATED ASSEMBLY INSTRUCTIONS	9/11/14	EMK	-
				REVISION LEVEL

THIS DRAWING IS THE SOLE PROPERTY OF
DIVERSIFIED WOOD CRAFTS. IT MAY NOT
BE ALTERED OR CHANGED WITHOUT
PERMISSION

DRAWING NUMBER:

A32 & A37 SERIES

SCALE:	SHEET:	REVISION:
NTS	2 OF 6	REV A

ASSEMBLY COMPONENTS

ITEMS INCLUDED	PART #	PART DESCRIPTION	QTY
WASHER - CENTER LEG BRACKET	100039	WASHER,SPLIT LOCK 5/16	4
WASHER - CENTER LEG BRACKET	218589	WASHER, 1/4" FLAT, USS ZINC PLATED	4
BOLT - CENTER LEG BRACKET	100638	BOLT,5/16X3 HEX HEAD	4
HEX NUT - CENTER BRACKET	100044	NUT,HEX 5/16-18 STEEL ZINC	4

NOTE:

1. ****XX**** INDICATES ITEMS ONLY USED FOR THE A32-10W, A32-12W, A37-10W, AND A37-12W.
2. QUANTITIES VARY WITH CHOICE OF TABLE STYLE.
3. A32 = 31 1/4"H, A37=37 1/4"H

DWN BY:	EMK	DWN DATE:	9/11/14
APR BY:		DATE APR:	
APR BY:		DATE APR:	

UNLESS OTHERWISE SPECIFIED
DIMENSION ARE IN INCHES
CABINET SQUARENESS ± .0625
FRACTIONAL VALUES ± 1/32"
- ALL VALUES ± OVERALL -



300 South Krueger Street
Suring, WI 54174
diversifiedwoodcrafts.com

TITLE:
**AUXILIARY WORKBENCH
TOOLS AND ASSEMBLY COMPONENTS**

A	CREATED ASSEMBLY INSTRUCTIONS	9/11/14	EMK	-
REV.	DESCRIPTION	DATE	NAME	ECH NO.

THIS DRAWING IS THE SOLE PROPERTY OF
DIVERSIFIED WOOD CRAFTS. IT MAY NOT
BE ALTERED OR CHANGED WITHOUT
PERMISSION

DRAWING NUMBER: A32 & A37 SERIES	SCALE: NTS	SHEET: 3 OF 6	REVISION: REV A
--	---------------	------------------	--------------------

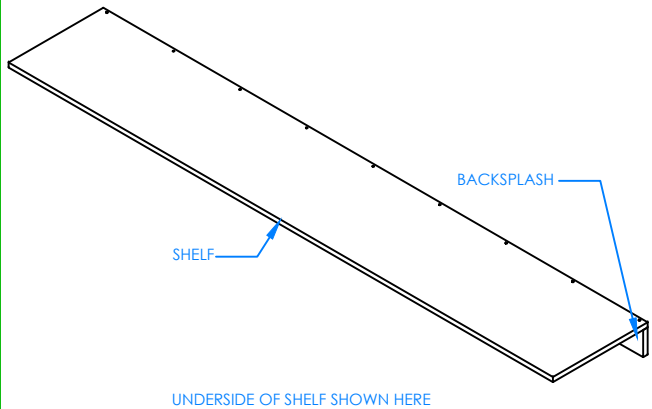

STEP 1:

SCREW THE SHELF BACKSPASH TO EACH SHELF BY GOING THROUGH THE PREDRILLED HOLES ON BACKSIDE OF SHELF. ONCE ASSEMBLED, SET ASIDE.

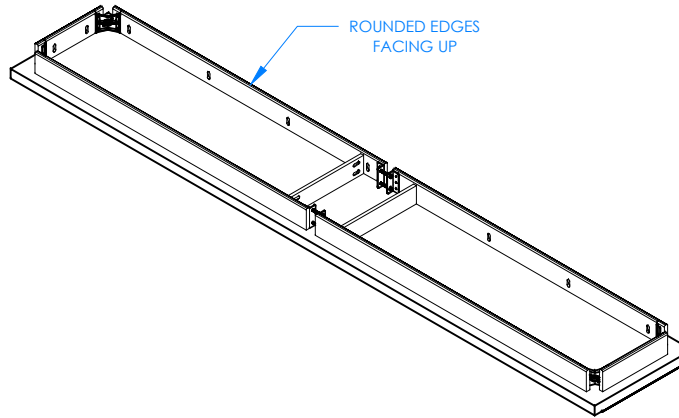

STEP 2:

LAY TOP ASSEMBLY ON FLOOR, WITH ROUNDED EDGES FACING UP. BE SURE TO LAY THE TOP ASSEMBLY ON A CLEAN SURFACE SO TABLE TOP DOES NOT GET DAMAGED.

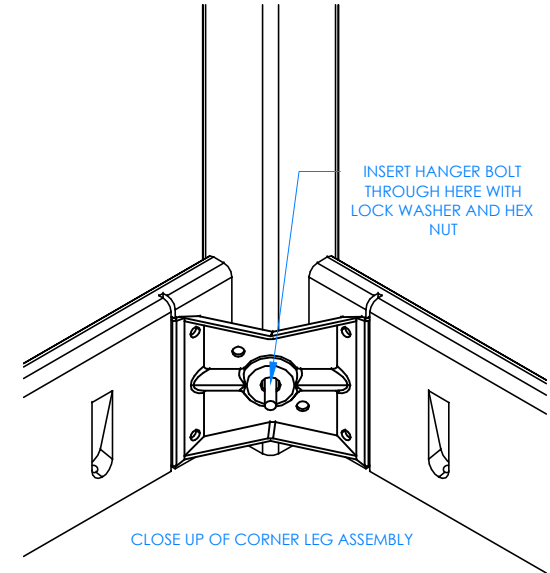

STEP 3:

INSERT HANGER BOLT THROUGH THE CORNER BRACKET AND PUT ON THE WASHER AND NUT PROVIDED. USING A 1/2" WRENCH OR 1/2" SOCKET AND TORQUE WRENCH, SCREW ON THE NUT BUT DO NOT TIGHTEN ALL THE WAY. REPEAT FOR OTHER 3 CORNER LEGS.

NOTE:

1.

DWN BY:	EMK	DWN DATE:	9/11/14
APR BY:		DATE APR:	
APR BY:		DATE APR:	

UNLESS OTHERWISE SPECIFIED DIMENSION ARE IN INCHES
 CABINET SQUARENESS ± .0625
 FRACTIONAL VALUES ± 1/32"
 - ALL VALUES ± OVERALL -



300 South Krueger Street
 Suring, WI 54174
 diversifiedwoodcrafts.com

TITLE:
AUXILIARY WORKBENCH ASSEMBLY INSTRUCTIONS

REV.	DESCRIPTION	DATE	NAME	ECH NO.
A	CREATED ASSEMBLY INSTRUCTIONS	9/11/14	EMK	-
REVISION LEVEL				

THIS DRAWING IS THE SOLE PROPERTY OF DIVERSIFIED WOOD CRAFTS. IT MAY NOT BE ALTERED OR CHANGED WITHOUT PERMISSION

DRAWING NUMBER:	SCALE:	SHEET:	REVISION:
A32 & A37 SERIES	NTS	4 OF 6	REV A

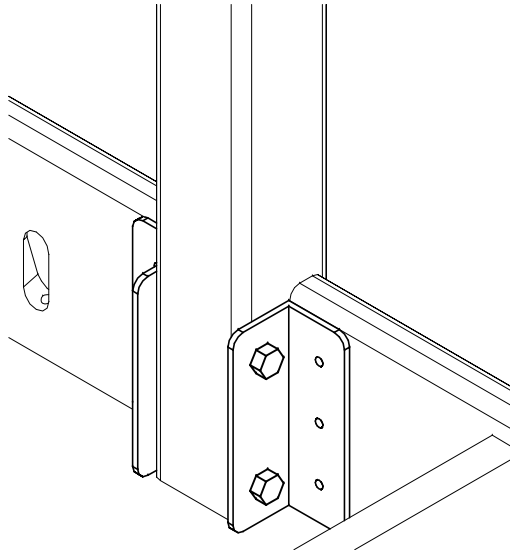

CLOSE UP OF CENTER LEG ASSEMBLY

STEP 4:

(IF YOUR MODEL DOES NOT HAVE 6 LEGS, SKIP TO STEP 5). PUT ONE OF THE CENTER LEGS IN PLACE AND INSERT THE BOLT, WASHERS, AND HEX NUT. USING A 1/2" WRENCH OR 1/2" SOCKET AND TORQUE WRENCH, SCREW ON THE NUT BUT AGAIN, DO NOT TIGHTEN ALL THE WAY. REPEAT FOR THE OTHER CENTER LEG.

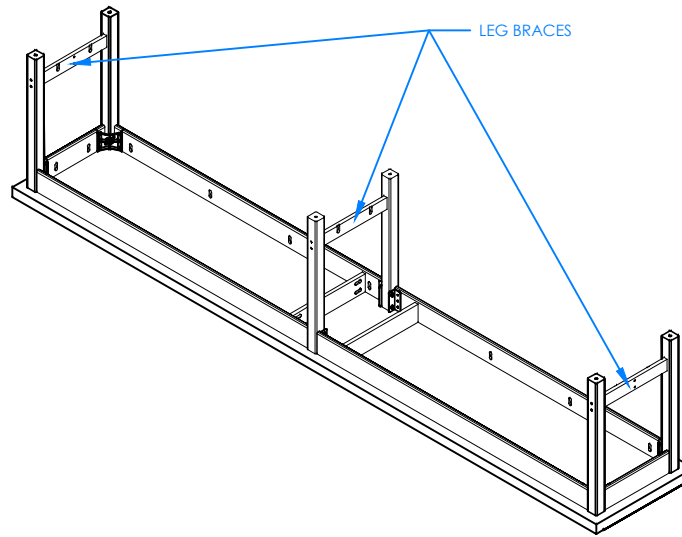

LEG BRACES

STEP 5:

USING A 4MM ALLEN WRENCH, INSERT THE LEG CONFIRMATS INTO ONE LEG AND SCREW INTO THE BRACE. REPEAT FOR OTHER SIDE OF BRACE. DO THE SAME FOR THE OTHER BRACES. MAKE SURE BRACES ARE STRAIGHT AND ALL THE CONFIRMATS ARE TIGHT.

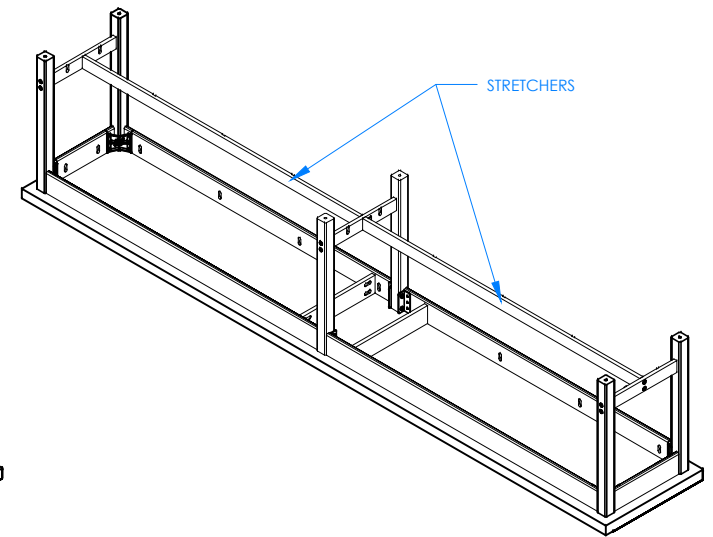

STRETCHERS

STEP 6:

INSERT THE STRETCHERS ONCE THE LEG BRACES ARE IN POSITION, ATTACH WITH THE STRETCHER CONFIRMATS AND TIGHTEN WITH A 4MM ALLEN WRENCH. IF YOU HAVE AN A32-10W, A32-12W, A37-10W, OR A37-12W, ATTACH STRETCHER TO CENTER BRACE USING THE STRETCHER BRACKETS PROVIDED. OFFSET BRACKETS ON EACH SIDE OF STRETCHER SO THE SCREWS DON'T HIT EACH OTHER. PREDRILL HOLES IN STRETCHERS WITH A 1/8" BIT AND ATTACH WITH #8 X 3/4" SCREWS. MAKE SURE EACH LEG BRACE AND STRETCHER IS TIGHT BEFORE MOVING ON. GO BACK TO STEP 2 AND TIGHTEN UP THE HANGER BOLTS FOR EACH CORNER LEG USING 1/2" WRENCH OR 1/2" SOCKET AND TORQUE WRENCH, TO A MINIMUM OF 12FT LBS BUT NOT TO EXCEED 17FT LBS.

NOTE:

- 1.

DWN BY:	EMK	DWN DATE:	9/11/14
APR BY:		DATE APR:	
APR BY:		DATE APR:	

UNLESS OTHERWISE SPECIFIED DIMENSION ARE IN INCHES
 CABINET SQUARENESS ± .0625
 FRACTIONAL VALUES ± 1/32"
 - ALL VALUES ± OVERALL -



300 South Krueger Street
 Suring, WI 54174
 diversifiedwoodcrafts.com

TITLE:
**AUXILIARY WORKBENCH
 ASSEMBLY INSTRUCTIONS**

REV.	DESCRIPTION	DATE	NAME	ECH NO.
A	CREATED ASSEMBLY INSTRUCTIONS	9/11/14	EMK	-
REVISION LEVEL				

THIS DRAWING IS THE SOLE PROPERTY OF DIVERSIFIED WOOD CRAFTS. IT MAY NOT BE ALTERED OR CHANGED WITHOUT PERMISSION

DRAWING NUMBER:	SCALE:	SHEET:	REVISION:
A32 & A37 SERIES	NTS	5 OF 6	REV A

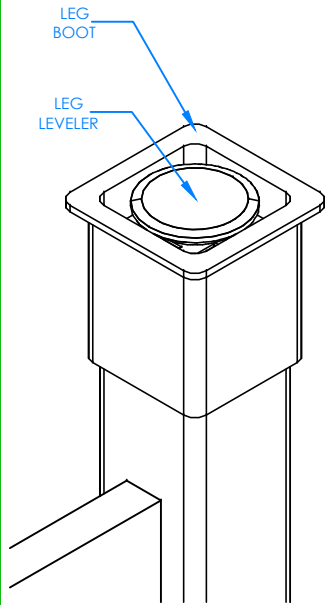

CLOSE UP OF LEG BOOT AND LEVELER ASSEMBLY

STEP 7:

SLIDE LEG BOOTS ONTO THE LEGS WITH FLARED END TOWARDS THE BOTTOM OF THE LEG. SCREW LEG LEVELERS INTO THE T-NUT IN THE BOTTOM OF THE LEG.

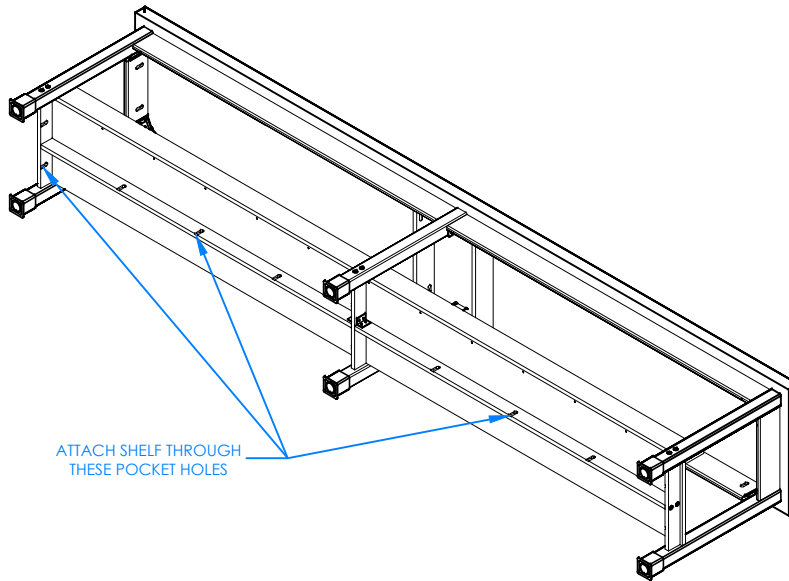

UNDERSIDE OF TABLE SHOWN

STEP 8:

ATTACH THE SHELF AND/OR SHELVES TO THE TOP OF THE STRETCHERS AND BRACES BY TIPPING TABLE ON ITS SIDE AND INSERTING THE SCREWS PROVIDED INTO THE POCKET HOLES ON BACK OF THE STRETCHERS AND BRACES.

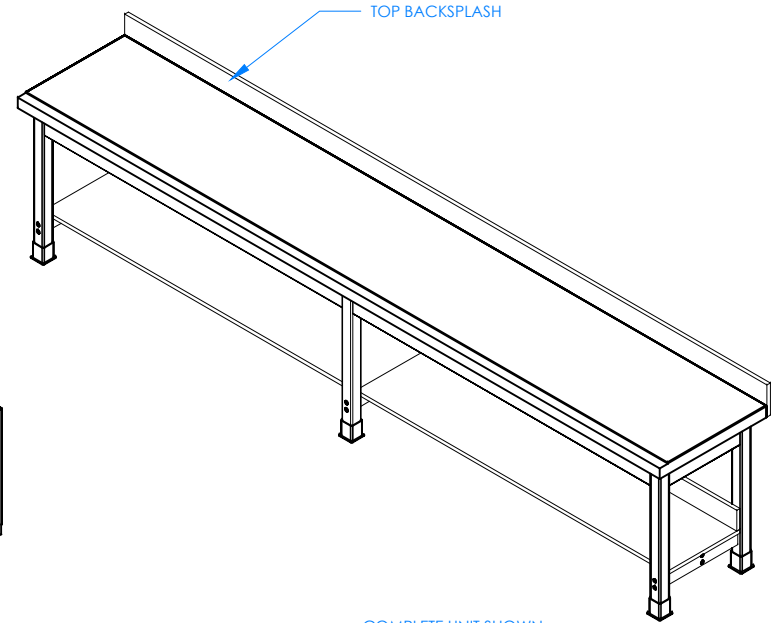

COMPLETE UNIT SHOWN

STEP 9:

TURN TABLE OVER SO TOP IS UP. SCREW ON THE BACKSPLASH TO THE TOP USING THE SCREWS PROVIDED. SET YOUR TABLE IN PLACE AND ADJUST THE LEG LEVELERS TO LEVEL THE TABLE. SLIDE LEG BOOTS DOWN TO THE FLOOR.

NOTE:

- 1.

DWN BY:	EMK	DWN DATE:	9/11/14
APR BY:		DATE APR:	
APR BY:		DATE APR:	

UNLESS OTHERWISE SPECIFIED DIMENSION ARE IN INCHES
 CABINET SQUARENESS ± .0625
 FRACTIONAL VALUES ± 1/32"
 - ALL VALUES ± OVERALL -



300 South Krueger Street
 Suring, WI 54174
 diversifiedwoodcrafts.com

TITLE:
**AUXILIARY WORKBENCH
 ASSEMBLY INSTRUCTIONS**

REV.	DESCRIPTION	DATE	NAME	ECH NO.
A	CREATED ASSEMBLY INSTRUCTIONS	9/11/14	EMK	-
REVISION LEVEL				

THIS DRAWING IS THE SOLE PROPERTY OF DIVERSIFIED WOOD CRAFTS. IT MAY NOT BE ALTERED OR CHANGED WITHOUT PERMISSION

DRAWING NUMBER:	SCALE:	SHEET:	REVISION:
A32 & A37 SERIES	NTS	6 OF 6	REV A