

YAKIMA



MEGA WARRIOR

RECOMMENDED TOOLS:

Phillips screwdriver
Tapemeasure or ruler

OUTILS RECOMMANDÉS

Tournevis cruciforme
Ruban à mesurer

HERRAMIENTAS RECOMENDADAS:

Destornillador Phillips
Cinta métrica o regla

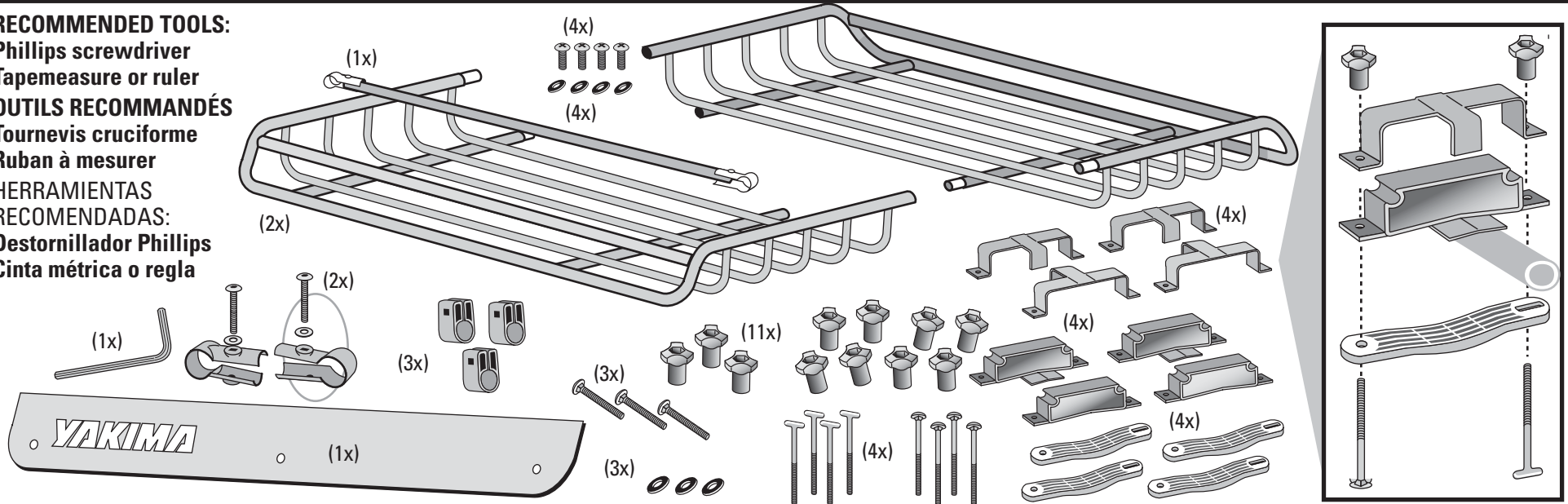

US ! LOAD LIMITS:

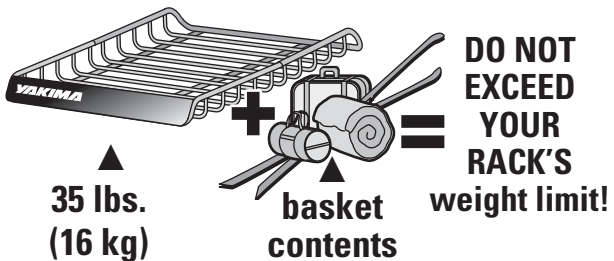

Always tie down long loads at front and rear.

FR ! LIMITES DE CHARGE:

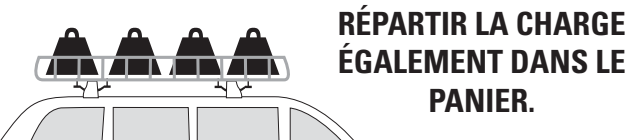
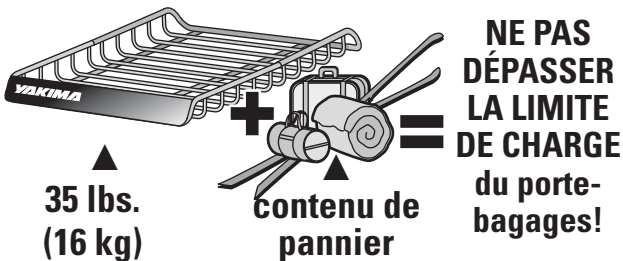

Toujours attacher les charges longues à l'avant et à l'arrière.

ES ! LIMITES DE CARGA:

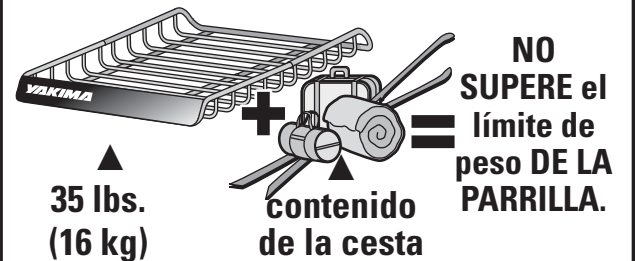

Siempre ate las cargas largas al frente al frente y atrás.

•IF YOU HAVE FIXED BARS:

1

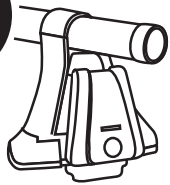

IF YOU HAVE "Q TOWERS"
OR BARS THAT CANNOT MOVE...
Continue to STEP 2.



**Q TOWER OWNERS:
NEVER REPOSITION THE Q TOWERS!**

•IF YOUR BARS MOVE:

IF YOU HAVE BARS THAT CAN BE MOVED...
Move the bars to minimum 30" (76cm) apart.



**TIGHTEN YOUR CROSSBARS
IF YOU LOOSENED THEM.**

2 ASSEMBLE THE BASKET.

• Remove the machine screws from the ends of the LoadWarrior tubes.

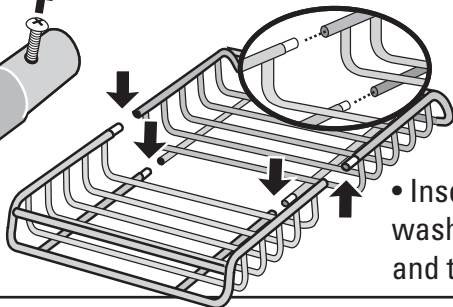
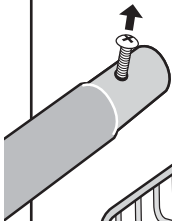

• Insert screws with washers into each joint and tighten them.

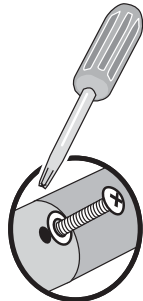

3 ATTACH FAIRING TO EITHER END OF BASKET.

Pry open the SnapArounds, attach them to the LOWER FRONT BAR.

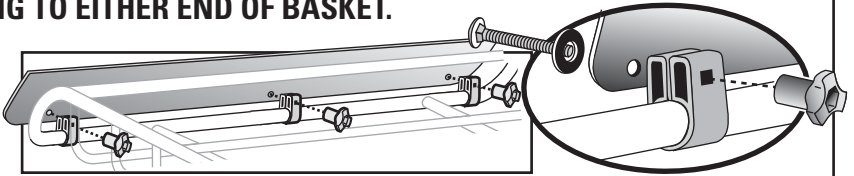
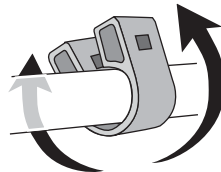

- Insert bolts through washers, fairing and SnapArounds.
- Attach knobs and TIGHTEN.

NOTE: The fairing can fold down when carrying accessories and long loads.

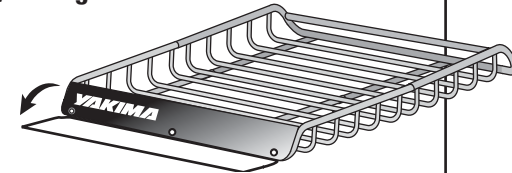

4 LOAD BASKET ONTO RACKS.

Center basket over your rack's crossbars.

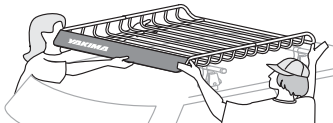

A friend would make this easier.



DO NOT ATTACH BRACKETS TO UNSTABLE POINTS.



Do not attach brackets at these locations.

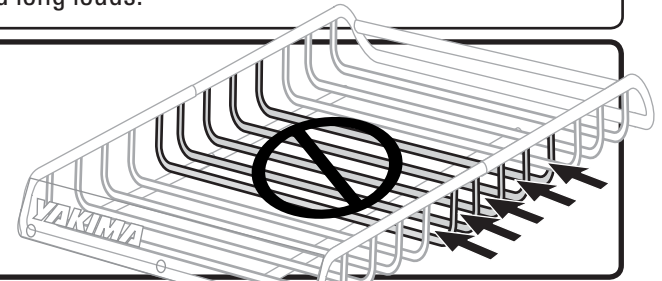

5 Position the support brackets above your vehicle's crossbars.

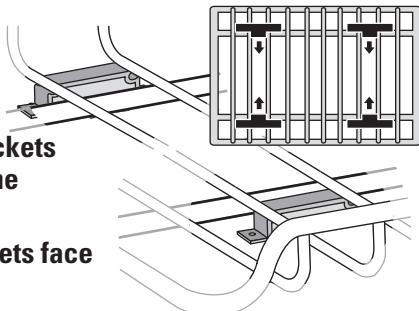

- Place the brackets **OUTSIDE** of the basket frame.
- Tabs on brackets face **INBOARD**.

KEEP BAR BELOW TAB!

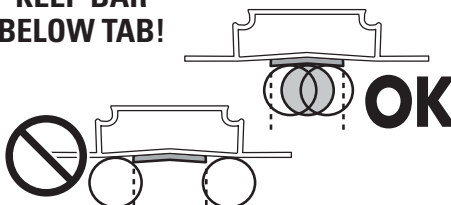

It may be necessary to move the bracket to a new position, or to adjust the basket position.

6 POSITION THE COVER BRACKETS.

Position cover bracket onto installed support brackets.

Hooked tab should cover the larger support bar.

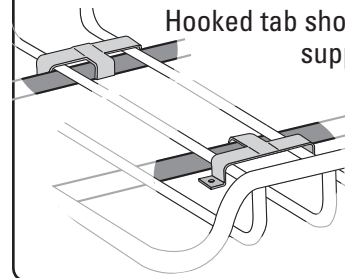

Arrow points inboard to center of vehicle.

7 ATTACH BOLTS.

Insert bolt into round hole, and T-bolt into slotted hole.

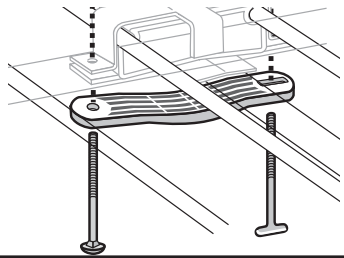

8 ATTACH THE KNOBS:

Engage the threads of the bolts.

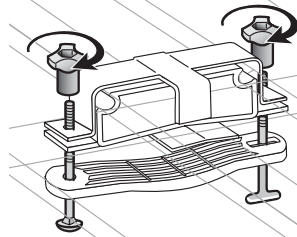

9 SECURE THE BASKET TO THE BARS.

Lock the T-Bolts.

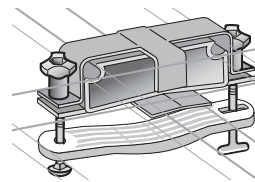

T-BOLT IS LOCKED when the "T" of the bolt is turned inside the hole:

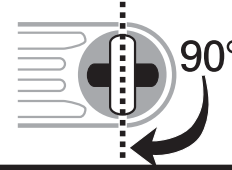

10

TIGHTEN THE KNOBS.

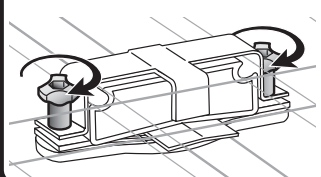

11 ATTACH LOAD BAR.

With a washer on the bolt, align the end clamps to the hole in the bar. Thread the bolts into the embedded nuts.

DO NOT COVER JOINT SCREWS WITH END CLAMPS.

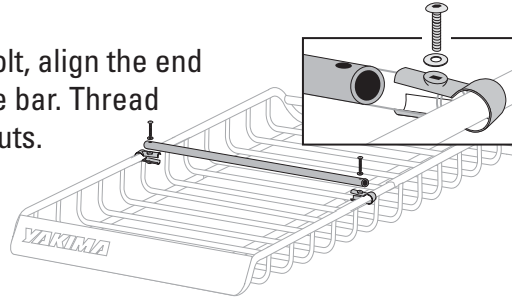
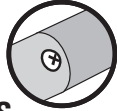

12 REFER TO THE DRAWINGS BELOW FOR BAR PLACEMENT, or to determine if the bar is required.

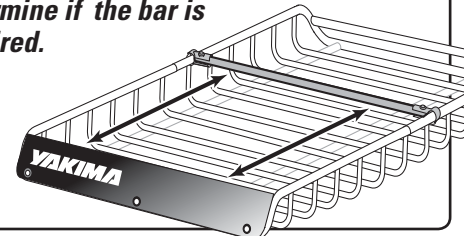

13 Tighten bolts while pushing the end clamps together.

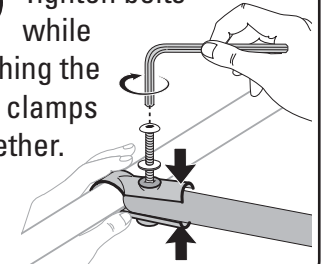

14 ACCESSORIES MUST BE ATTACHED TO THE FRONT OF THE BASKET (FRONT OF VEHICLE).

BIKES

- Attach carrier at front of basket and to load bar.
- Adjust the bar for load stability.

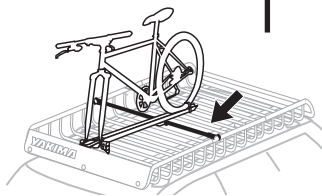
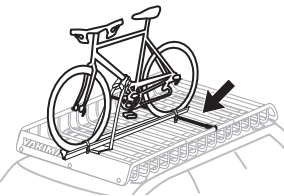

BOATS

- For shorter boats, attach accessory at front of basket and to load bar.
- Longer loads, such as canoes or sea kayaks, require the load bar to be removed.

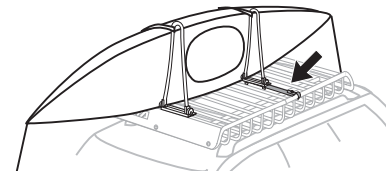
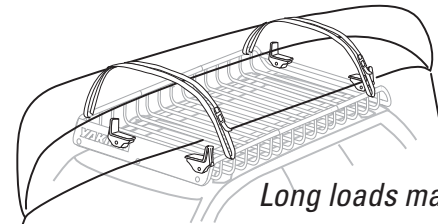

Long loads may interfere with LoadBar.

SKIS

- Attach accessory at front of basket and to load bar.

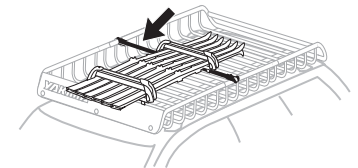

15 CHECK INSTALLATION:

Make sure installation is secure by tugging at basket.

The basket should NOT SLIDE on the bars. Tighten knobs.



TO REMOVE THE BASKET, DO NOT DISASSEMBLE THE HARDWARE.

- Loosen the knobs until barely attached.
- Unlock the T-bolts and let curved brackets swing freely.
- Remove basket.

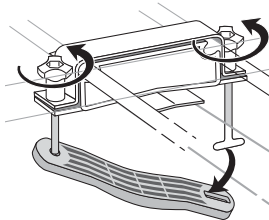

USE CAUTION WHEN OPENING YOUR HATCH.

On some vehicles, hatch interference is unavoidable.

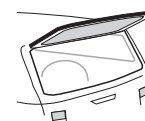

Always tie down long loads to front and rear of vehicle.



1

•SI LES BARRES SONT FIXES:

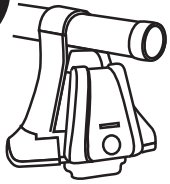

SI L'ON A DES "PIEDS Q" OU DES BARRES QUI NE BOUGENT PAS... passer à l'opération 2.



PROPRIÉTAIRES DE PIEDS Q: IL NE FAUT JAMAIS MODIFIER LA POSITION DES PIEDS Q!

•SI LES BARRES SONT MOBILES:

S'IL EST POSSIBLE DE DÉPLACER LES BARRES... placer les barres à 76 cm (30 po) l'une de l'autre.



RESSERRER LES BARRES SI ON LES A DESSERRÉES.

2

ASSEMBLER LE PANIER.

- Enlever les vis à métal qui se trouvent dans le bout des tubes du LoadWarrior.

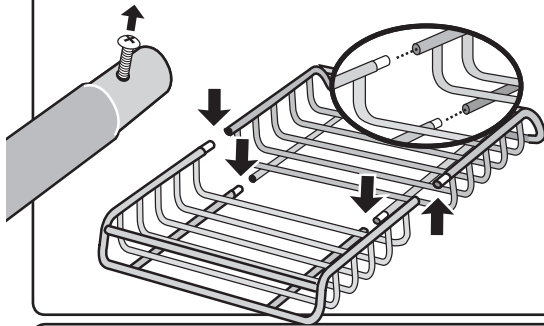

- Poser les bonnes vis dans les joints et les serrer.

3

POSER LE DÉFLECTEUR À L'UN OU L'AUTRE BOUT DU PANIER.

Écarter les colliers SnapAround et les engager sur la BARRE AVANT INFÉRIEURE.

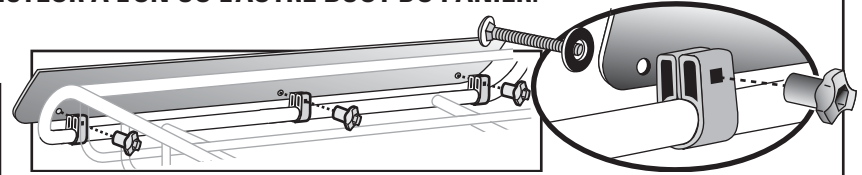
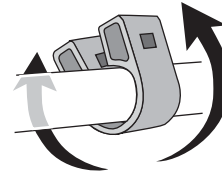

- Glisser les boulons à travers la rondelle, le déflecteur et le collier.
- Installer le bouton et SERRER.

REMARQUE: On peut rabattre le déflecteur quand on transporte des accessoires ou une charge longue.

4

LOAD BASKET ONTO RACKS.

Center basket over your rack's crossbars.

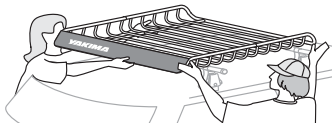

A friend would make this easier.



NE PAS FIXER LES ÉTRIERS À DES POINTS INSTABLES.



Ne pas fixer les étriers à ces endroits.

(VUE DE CÔTÉ)

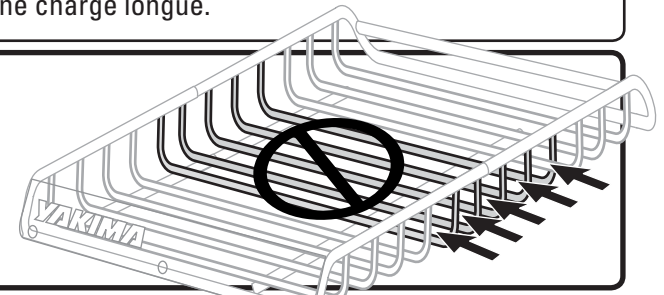

5

POSITIONNER LES ÉTRIERS INFÉRIEURS AU-DESSUS DES BARRES TRANSVERSALES DU VÉHICULE.

- Placer les étriers À L'EXTÉRIEUR du cadre du panier.
- La patte des étriers doit pointer VERS L'INTÉRIEUR.

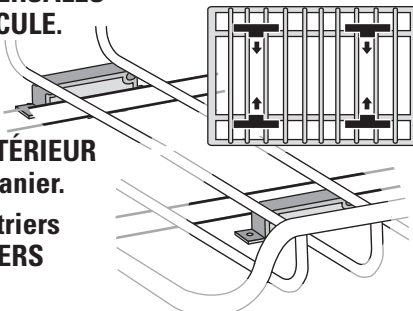

LA BARRE DOIT ÊTRE SOUS LA PATTE!



OK
BIEN

Il faudra peut-être déplacer l'étrier ailleurs ou modifier la position du panier.

6

METTRE EN PLACE LES ÉTRIERS SUPÉRIEURS.

Placer les étriers supérieurs sur les étriers inférieurs.

La patte recourbée doit recouvrir le tube du panier.

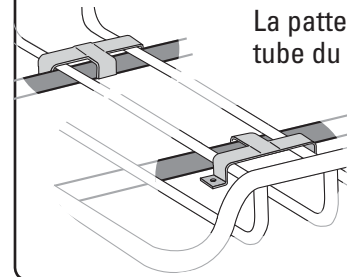

La flèche pointe vers l'intérieur du véhicule.

7 POSER LES BOULONS.
Glisser le boulon à tête ronde dans le trou rond et le boulon en "T" dans la fente.

8 METTRE LES BOUTONS EN PLACE. Engager les premiers filets sur les boulons.

9 FIXER LE PANIER AUX BARRES TRANSVERSALES.
Verrouiller les boulons en "T".

LE BOULON EN "T" EST VERROUILLÉ
quand sa tête en "T" est perpendiculaire à la fente:

10 SERRER LES BOUTONS.

11 FIXER LA BARRE
Après y avoir mis une rondelle, enfiler le boulon à travers les trous de l'embout et de la barre.
Engager le boulon dans l'écrou incorporé.

NE PAS POSER LES EMBOUTS PAR-DESSUS LES VIS DES JOINTS..

12 CONSULTER LES ILLUSTRATIONS CI-DESSOUS POUR SAVOIR où placer la barre, ou s'il faut l'installer.

13 Serrer les boulons en comprimant les embouts.

14 LES ACCESSOIRES DOIVENT ÊTRE FIXÉS À L'AVANT DU PANIER (L'AVANT DU VÉHICULE).

<p>VÉLOS</p> <ul style="list-style-type: none"> • Fixer le porte-vélos à l'avant du panier et à la barre intermédiaire. • Placer la barre de manière que la charge soit stable. 	<p>EMBARCATIONS</p> <ul style="list-style-type: none"> • Pour les embarcations courtes, fixer l'accessoire à l'avant du panier et à la barre intermédiaire. • Pour les embarcations longues, comme les canots ou les kayaks de mer, il faut enlever la barre intermédiaire. 	<p>SKIS</p> <ul style="list-style-type: none"> • Fixer l'accessoire à l'avant du panier et à la barre intermédiaire.
--	--	--

Si la charge est longue, la barre intermédiaire peut gêner

15 VÉRIFIER LE MONTAGE:
Contrôler la solidité du montage en essayant de bouger le panier.
Le panier **NE DOIT PAS GLISSER** sur les barres transversales.
Serrer les boutons au besoin.

POUR ENLEVER LE PANIER, NE PAS DÉMONTÉ LES ÉTRIERS.

- Desserrer les boutons presque complètement.
- Déverrouiller les boulons en "T" et décrocher la patte courbe.
- Enlever le panier.

FAIRE ATTENTION EN OUVRANT LE HAYON.

Sur certains véhicules, le hayon touche au panier.

Toujours attacher les charges longues à l'avant et à l'arrière.

1

•PARA TRAVESAÑOS FIJOS:

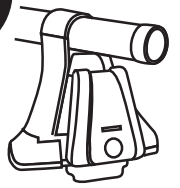

SI TIENE SOPORTES "Q-TOWERS" O TRAVESAÑOS QUE NO PUEDEN MOVERSE: Continúe al Paso 2.

¡ATENCIÓN: NUNCA CAMBIE DE LUGAR LOS Q-TOWERS!

•PARA TRAVESAÑOS MÓVILES:

SI LOS TRAVESAÑOS PUEDEN MOVERSE:
Sepárelos a 76 cm (30").

¡AJUSTE LOS TRAVESAÑOS SI LOS HA AFLOJADO!

2 MONTE LA CESTA.

• Quite los tornillos mecánicos de los extremos de los tubos del LoadWarrior.

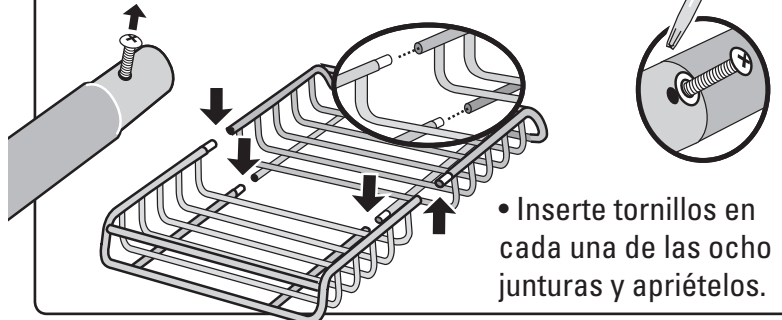

• Inserte tornillos en cada una de las ocho juntas y apriételes.

3 COLOQUE LAS CARENAS A AMBOS EXTREMOS DE LA CESTA.

Abra los broches SnapAround, y colóquelos sobre el travesaño inferior delantero.

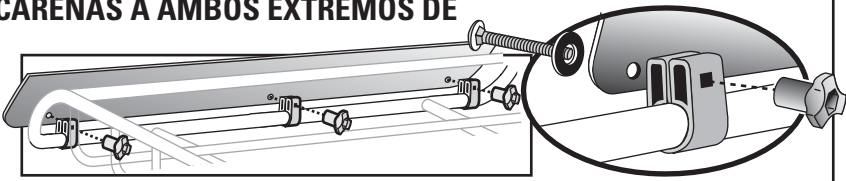
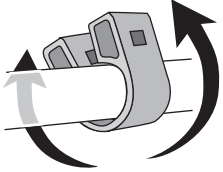

- Inserte tornillos a través de las arandelas, la carena y los SnapAround.
- Coloque las perillas y ajuste.

NOTA: Las carenas pueden bajarse para transportar accesorios o cargas largas.

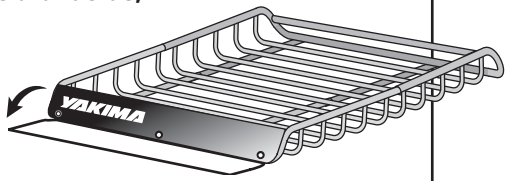

4 COLOQUE LA CESTA SOBRE LA PARRILLA. Centre la cesta sobre los travesaños.

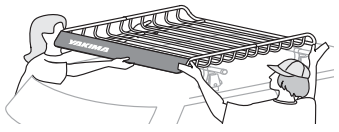

Un amigo puede facilitar esta tarea.



NO COLOQUE LAS ESCUADRAS EN PUNTOS INESTABLES.



No coloque escuadras en estos lugares.

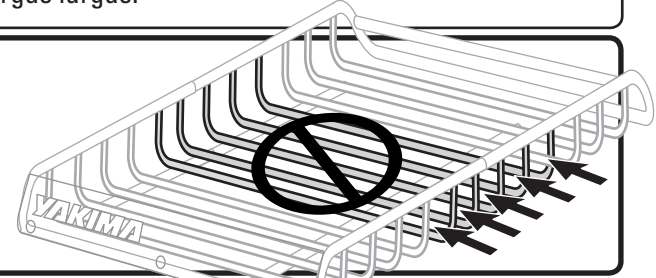

5 COLOQUE LAS ESCUADRAS DE APOYO ENCIMA DE LOS TRAVESAÑOS DEL VEHÍCULO.

- Coloque las escuadras FUERA de l marco de la cesta.
- Las aletas de las escuadras deben dirigirse HACIA ADENTRO.

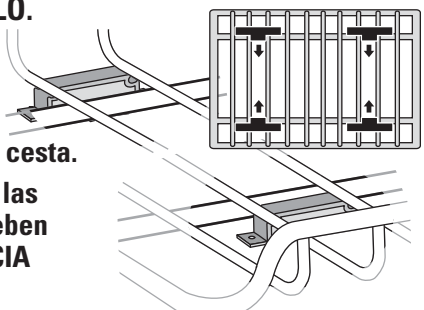

¡MANTENGA EL TRAVESAÑO DEBAJO DE LA ALETA!

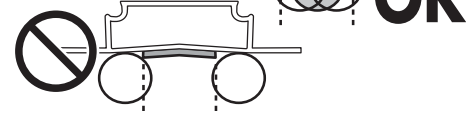

Puede ser necesario mover la escuadra a una nueva posición, o ajustar la posición de la cesta.

6 COLOQUE LAS ESCUADRAS SUPERIORES.

Coloque las escuadras superiores sobre las escuadras de apoyo instaladas.

La aleta con gancho debe ir por encima del travesaño de apoyo más grande.

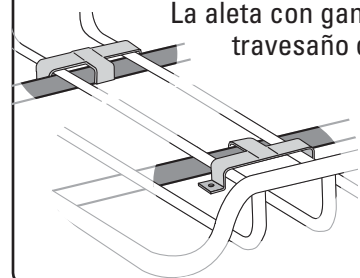

La flecha apunta hacia dentro al centro del vehículo.

7 COLOQUE LOS TORNILLOS.
 Inserte el tornillo común en el agujero redondo y el tornillo T en el agujero con ranura.

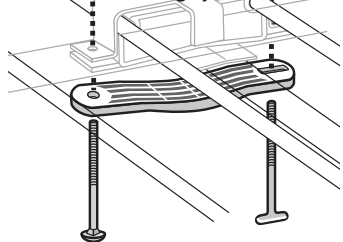

8 COLOQUE LAS PERILLAS:
 Siga la rosca de los tornillos.

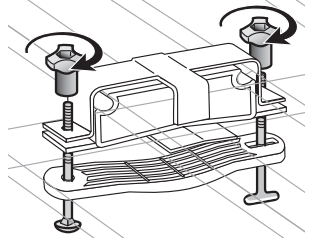

9 ASEGURE LA CESTA A LOS TRAVESAÑOS.
 Tranque los tornillos T.

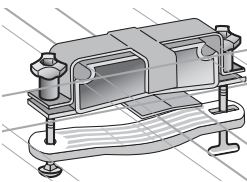

EL TORNILLO 'T' ESTÁ ASEGURADO cuando la "T" del tornillo queda dentro del agujero:

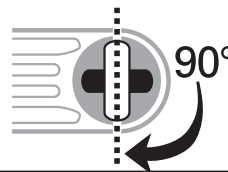

10 AJUSTE LAS PERILLAS.

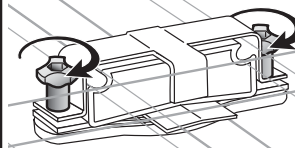

11 MONTE LA BARRA Con una arandela en el tornillo, haga coincidir las piezas de extremo con el agujero en la barra. Introduzca los tornillos en las tuercas roscadas.

NO CUBRA LOS TORNILLOS DE LAS JUNTURAS CON LAS PIEZAS DE EXTREMO.

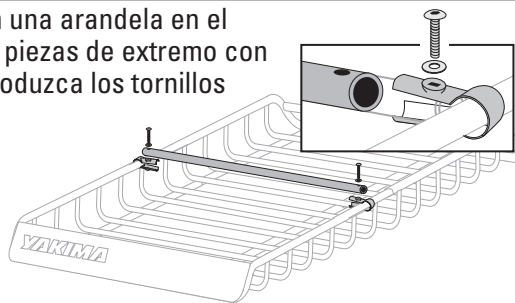
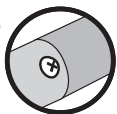

12 VEA LOS DIBUJOS QUE SIGUEN PARA SABER DÓNDE COLOCAR LA BARRA o saber si la necesita.

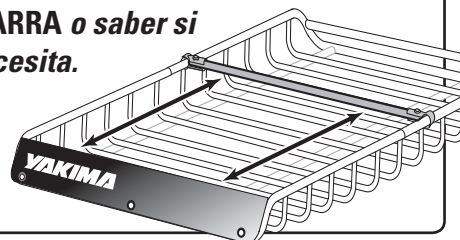

13 Ajuste los tornillos mientras aprieta para unir las piezas de extremo.



14 LOS ACCESORIOS DEBEN COLOCARSE AL FRENTE DE LA CESTA (FRENTE DEL VEHÍCULO).

BICICLETAS



- Monte el portabicicletas al frente de la cesta y sobre la barra de carga.
- Ajuste la barra para lograr estabilidad.

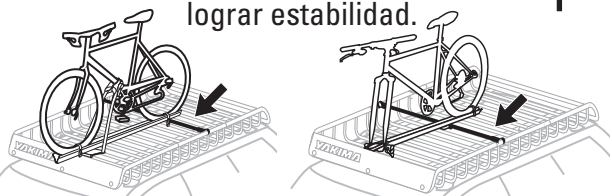

EMBARCACIONES



- Para botes cortos, coloque el accesorio al frente de la cesta y sobre la barra.
- Para canoas, kayaks marinos y similares se debe sacar la barra.

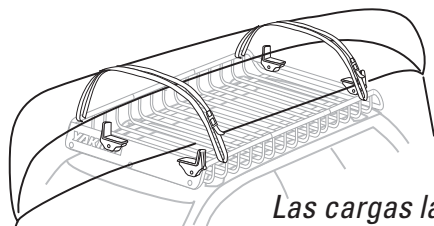

ESQUÍES



- Coloque el accesorio al frente de la cesta y sobre la barra.

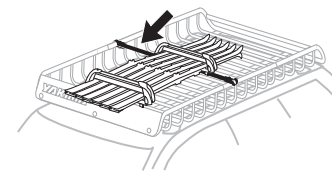

Las cargas largas pueden interferir con la barra

15 VERIFIQUE LA INSTALACIÓN:
 Cerciérese de que la instalación está segura sacudiendo la cesta.

La cesta **NO DEBE** DESLIZARSE sobre los travesaños. Ajuste las perillas si es necesario.



PARA SACAR LA CESTA, NO DESMONTE EL CONJUNTO.

- Afloje las perillas hasta que quedan casi sueltas.
- Destranque los tornillos T para que las escuadras curvas cuelguen libres.
- Saque la cesta.

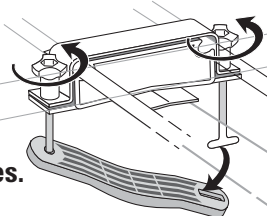

TENGA CUIDADO CUANDO ABRA LA MEDIA PUERTA TRASERA.



En algunos vehículos, es inevitable la interferencia.

Siempre ate las cargas largas al frente al frente y atrás.



US**MAINTENANCE**

Use non-water soluble lubricant on bolts.
Use a soft cloth with water and mild detergent to clean plastic parts.

**NOT RECOMMENDED FOR USE WITH
DRIVE THROUGH CAR WASHES.**

WARNING

Attachment hardware can loosen over time. Check before each use, and tighten if necessary. Failure to perform safety checks can result in property damage, personal injury, or death.

**TECHNICAL ASSISTANCE
OR REPLACEMENT PARTS:**

Contact your dealer or call (888) 925-4621
Monday through Friday
7:00 am to 5:00 pm PST



This product is covered by YAKIMA's
"Love It Till You Leave It" Limited Lifetime Warranty
To obtain a copy of this warranty, go online to
www.yakima.com
or email us at yakwarranty@yakima.com
or call (888) 925-4621

KEEP THESE INSTRUCTIONS!**FR****ENTRETIEN**

Appliquer un lubrifiant non soluble à l'eau sur les boulons. Nettoyer les pièces en plastique avec un chiffon doux et de l'eau savonneuse.

**IL EST DÉCONSEILLÉ DE PASSER DANS UN
LAVE-AUTO AUTOMATIQUE QUAND LE PORTE-
BAGAGES EST EN PLACE.**

AVERTISSEMENT

Les dispositifs de fixation peuvent se desserrer à la longue. Les inspecter avant chaque utilisation et les resserrer au besoin. Si l'on n'effectue pas les vérifications de sécurité avant de prendre la route, on risque de provoquer des dommages, des blessures ou même la mort.

**RENSEIGNEMENTS TECHNIQUES OU PIÈCES
DE RECHANGE:** prière de contacter votre
dépositaire ou appelez-nous au (888) 925-4621
du lundi au vendredi, entre 7 heures et 17
heures, heure du Pacifique.



Ce produit est couvert par la garantie limitée
« Tant que durera notre histoire d'amour » YAKIMA
Pour se procurer une copie de cette garantie, aller en
ligne à www.yakima.com <<http://www.yakima.com/>>
ou nous envoyer un courriel à yakwarranty@yakima.com
<<mailto:yakwarranty@yakima.com>>
ou appeler au (888) 925-4621

CONSERVER CES INSTRUCTIONS!**ES****MANTENIMIENTO**

Use lubricante no soluble en agua en los cerrojos.
Use un paño blando con agua y detergente suave para limpiar las partes de plástico.

**NO SE RECOMIENDA UTILIZAR EN
LAVADEROS AUTOMÁTICOS DE VEHÍCULOS.**

ADVERTENCIA

Las uniones y piezas de montaje pueden aflojarse con el tiempo. Verifique antes de cada uso y ajuste si es necesario. Si no verifica la seguridad podrían producirse daños a la propiedad, heridas corporales o muerte.

**SI NECESITA MÁS ASISTENCIA TÉCNICA O
REPUESTOS:** Comuníquese con su concesionario
o llámenos al (888) 925-4621 de lunes a viernes
de 7:00 am a 5:00 pm, hora del Pacífico



Este producto está cubierto por la garantía limitada a vida "mientras dure el romance" de YAKIMA. Para obtener una copia de esta garantía, visítenos en www.yakima.com, envíenos un correo electrónico a yakwarranty@yakima.com o llámenos al (888) 925-4621

¡CONSERVE ESTAS INSTRUCCIONES!