

**Semi-Automatic
Strapping Machine**
OPERATION MANUAL
MAINTENANCE MANUAL
PARTS LIST

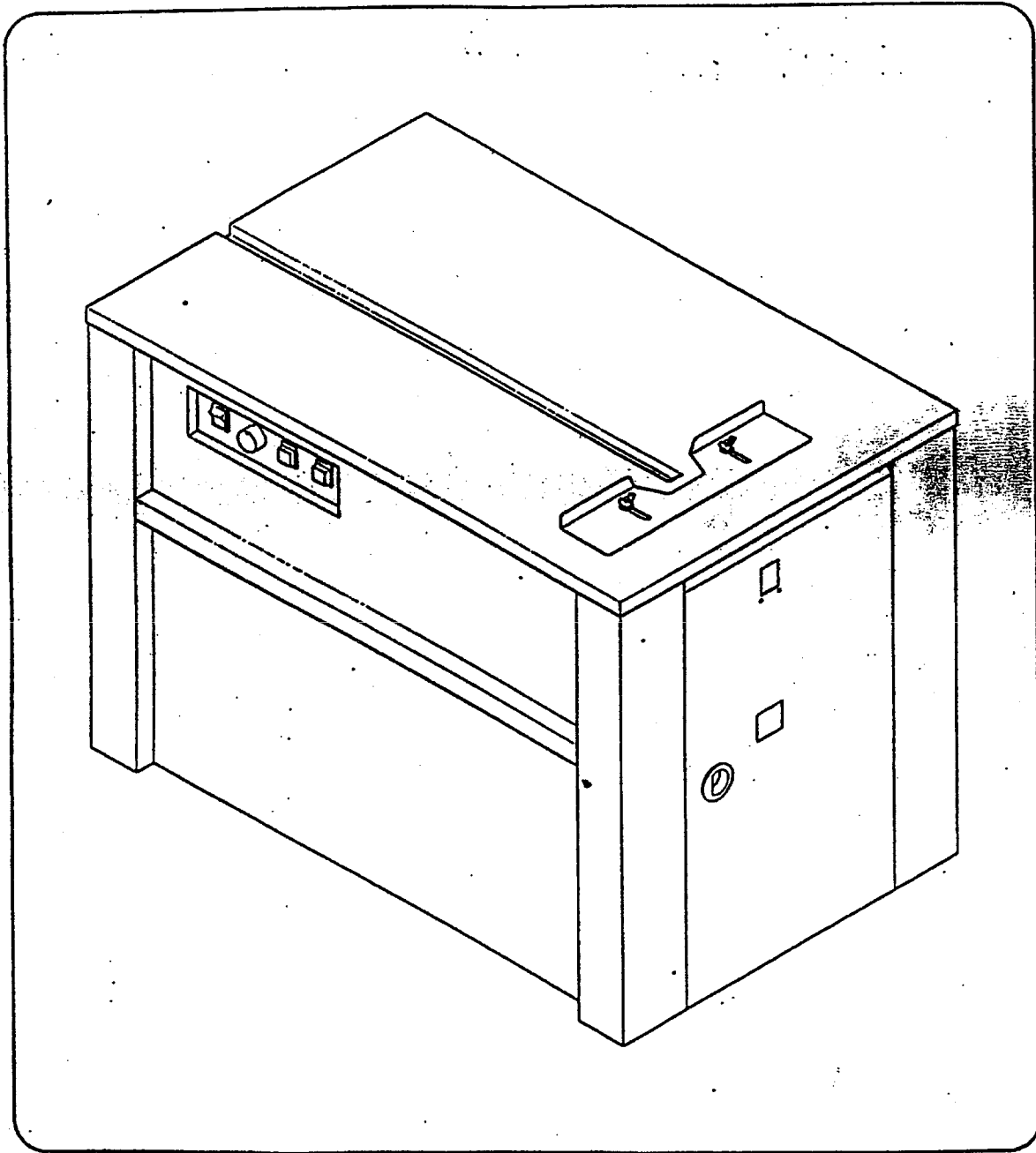

Read all instructions before operating this product.

Please notice if date of publish is suitable and correct when using this brochure.

Please confirm voltage specification of machine when using this brochure.

CONTENTS

	Page
CONTENTS	1
LIST OF ILLUSTRATIONS	2
SECTION 1 - SIMPLE OPERATION	3
Operating instructions.....	3
SECTION 2 - FUNCTION AND OPERATING	4
Parts function	4
Installation of coil	4
Threading procedure	6
Operating procedure	6
Welding temp., strap tension and strap guide adjustments	7
Welding temperature	7
Strap tension	7
Strap guide adjustment	7
Blower	7
SECTION 3 - PRINCIPLES OF OPERATION	9
General	9
Mechanical description	9
Tightening	9
Welding	9
Feeding	11
Electrical description	11
Instant heating system	11
SECTION 4 - ADJUSTMENTS AND CLEARANCES	12
General	12
Top slide	12
Tension trip arm	13
Switch cam	13
Plunger and end gripper	14
Tension lever	14
Feed roller and tension rollers	15
SECTION 5 - LUBRICATION	17
SECTION 6 - MAINTENANCE	18
General	18
Inspection	18
Trouble shooting	18

LIST OF ILLUSTRATIONS

Figure	Subject	Page
1	SIMPLE OPERATION	3
2	CONTROL PANNEL ON FRONT PLATE	5
3	OPERATING ADJUSTMENTS	5
4	5
5	5
6	5
7	5
8	STRAP THREADING DIAGRAM	6
9	STRAP GUIDE ADJUSTMENTS	8
10	STRAPPING OPERATIONAL DETAILS	10
11	TOP SLIDE CLEARANCE	12
12	TENSION TRIP ARM ADJUSTMENT DETAILS	13
13	CAM SWITCH ADJUSTMENT DETAILS	14
14	PLUNGER AND END GRIPPER CLEARANCE DETAILS	14
15	TENSION LEVER ADJUSTMENT DETAILS	14
16	ROLLER ASSEMBLY ADJUSTMENT DETAILS	15
17	TOP SLIDE, GUIDE PLATES, PLUNGER, END GRIPPER, AND HOLDING GRIPPER	17
18	COMPONENT LOCATIONS, FRONT VIEW	20

SECTION 1 SIMPLE OPERATION

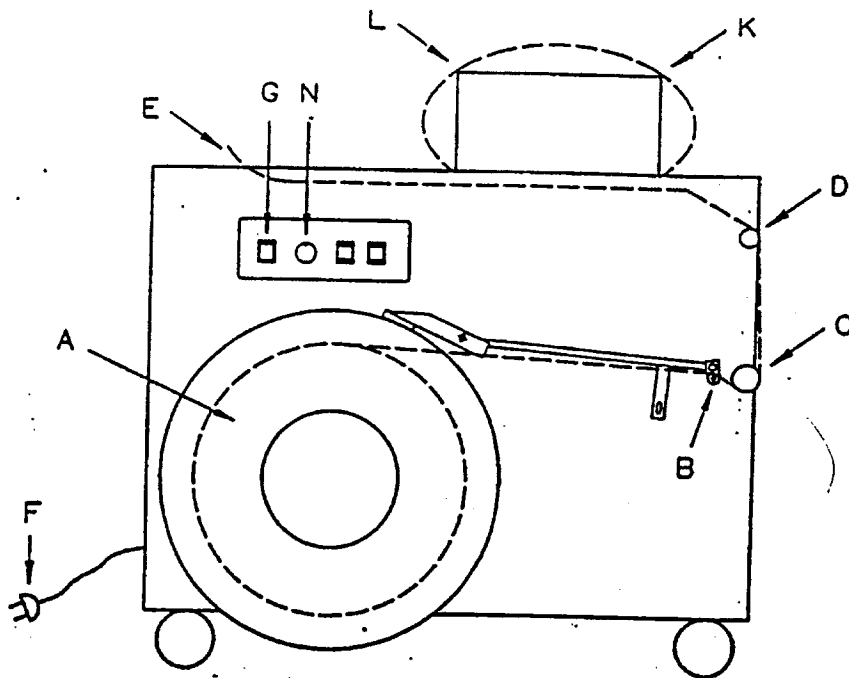

FIGURE 1. SIMPLE OPERATION

OPERATION

1. Install coil A on dispenser (refer to Section 2, Installation of Coil).
2. Open the right door. Thread strap through looper B, in take-up arm, pass through C to outdoors, and insert between guide and roller D.
3. Continue to push strap between guide and roller D until strap end appears on point E in table top. Close the right door.
4. Connect power plug F to power source.
5. Set POWER switch G to ON position.
6. Put package K on the table top.
7. Manually pull the strap L to encircle package.
8. Insert strap end into slot M. Then machine will work automatically.
9. After strapping, remove the package.
10. Adjust STRAP LENGTH control N to feed the length desired.
11. Adjust the strap tension if necessary. (refer to Section 2, Strap Tension, fig. 3)

SECTION 2-FUNCTION AND OPERATING

PARTS FUNCTION

1. **POWER SWITCH:** Press this button to get electric power.
2. **TIMER:** Rotate clockwise to lengthen the strap. Counterclockwise shorter the strap.
3. **FEED BUTTON:** Press this button, and will get the length required.
4. **RE-SET BUTTON :** Our machine "RE-SET" button include two functions. (strap backward). Press this button double times to get "RE-SET" function (To put the machine in neutral condition). If press this button and keep about 2 seconds, and will get the function both of "MANUAL" and "RE-SET"
5. **HEATER TEMPERATURE CONTROL:** Rotate the knob (Fig.9) clockwise to raise the heater blade temperature. Or counterclockwise to lower the temperature.
6. **HEATING COOLING TIME CONTROL:** To push this button (Fig.3) forward to the position "2" to get longer cooling time. To push this button backward to the position "0" to get shorter cooling time. The position "1" is in standard condition.
7. **STRAP TENSION KNOB:** Rotate the knob (Fig.3) clockwise to increase the tension. Counterclockwise to decrease the tension.
8. **STRAP WIDTH ADJUST GUIDES:** Loosen the setscrew on the strap guides and then adjust strap guides according to the width of the strap used. (Fig.3)

INSTALLATION OF COIL

To install the coil as the following proceeds:

1. Open the left door. Remove the dispenser (Fig.4), and lay it down horizontally. Slightly hold the lower flange and pull up the upper flange by release the wing nut. (Fig.5)
2. Mount a new coil on the lower flange. Place the upper flange by fixing the wing nut, and then remove the paper wrap from the new coil. (Fig.6)
3. Install the dispenser on cradle in the machine from left door. (Fig.7)
4. Close the door.

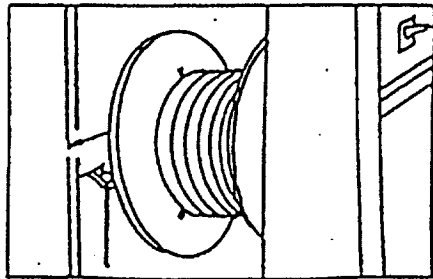

FIGURE 4

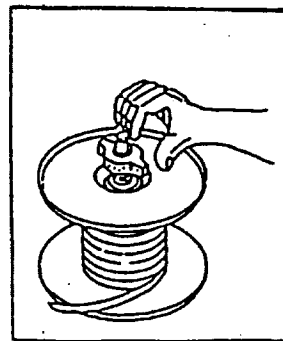

FIGURE 5

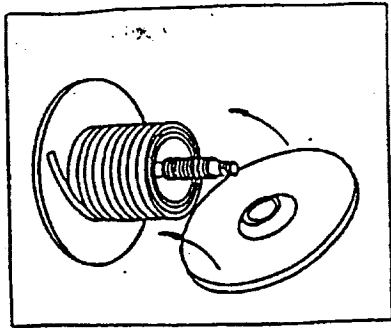

FIGURE 6

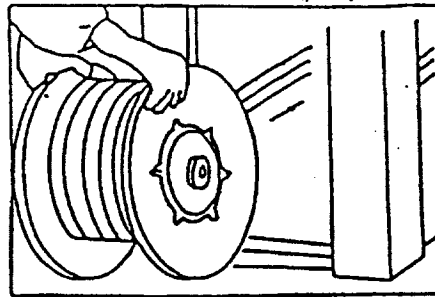

FIGURE 7

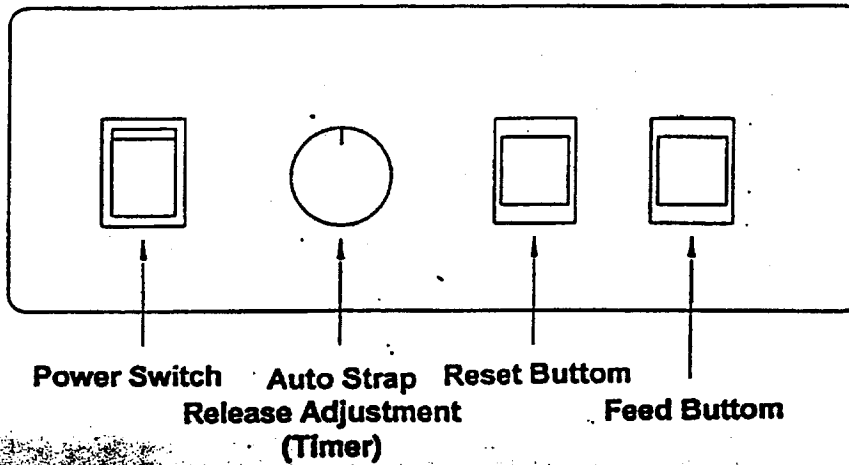

FIGURE 2 CONTROL PANEL ON FRONT PLATE

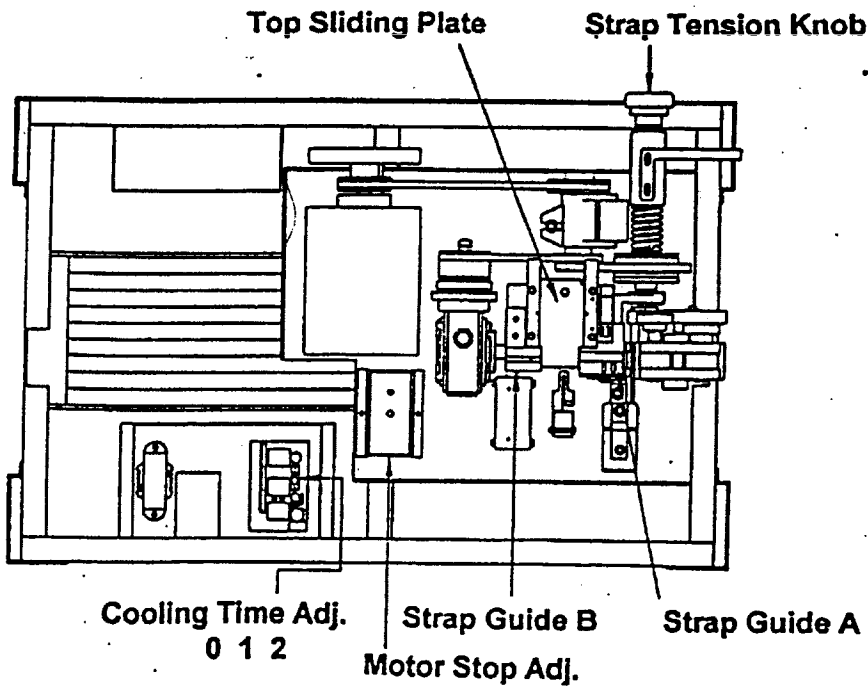

FIGURE 3 MAJOR COMPONENTS TOP VIEW

THREADING PROCEDURE

Before strapping, the threading procedure should be completed as follows: (Fig8)

1. Open the right door.
2. Make sure that strap is from top of coil, if not, turn the dispenser up side down, thread strap through looper (A) in take-up arm, and insert between the two rollers on point B.
3. Insert strap between guide and roller (C).
4. Continue to push until strap appears on the table top.
5. Close the right door.

OPERATING PROCEDURE

1. Connect the power plug to power source.
2. Set POWER switch to ON position.
3. Put the package on the table top cover.
4. Press feed button to gain enough for encircling package.
(Also can pull strap manually to obtain enough length)
5. Encircle package and insert strap into slot on the table top cover then strapping is automatically initiated, withdraw hands before strapping.
6. After package is automatically strapped, remove package.
7. Adjust AUTO STRAP RELEASE to get the length required.
8. Adjust STRAP TENSION to the tension desired. (See the paragraph below)
9. Inspect strap welding. Adjust heater blade temperature if necessary.
(See the paragraph below)
10. Inspect the welding alignment. Adjust strap guide if necessary.
(See the paragraph below)

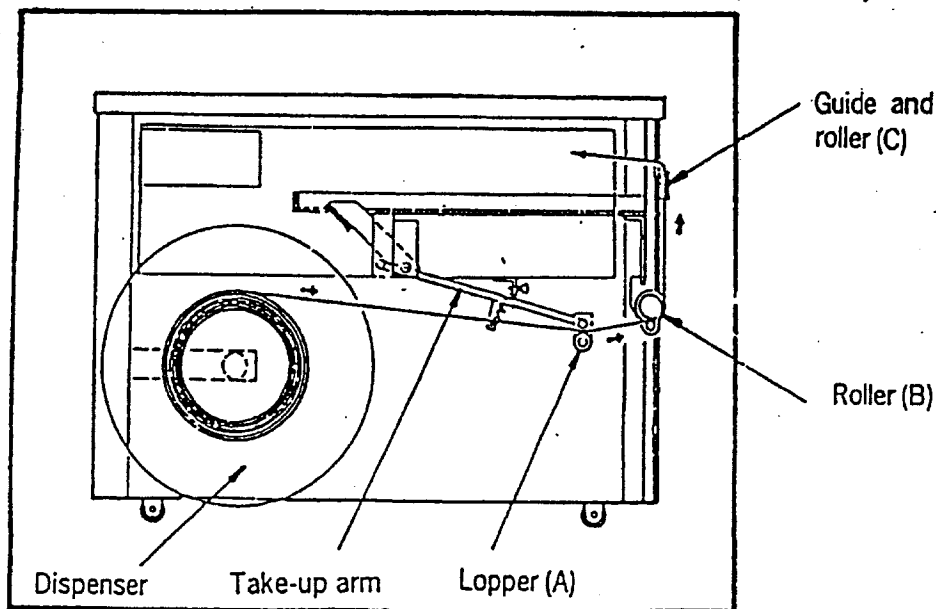
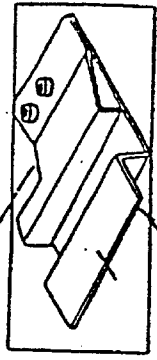
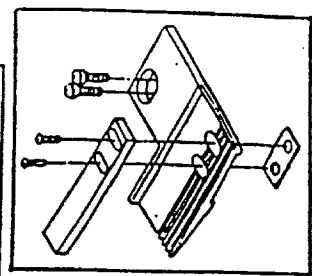
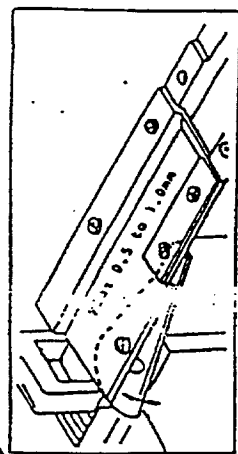
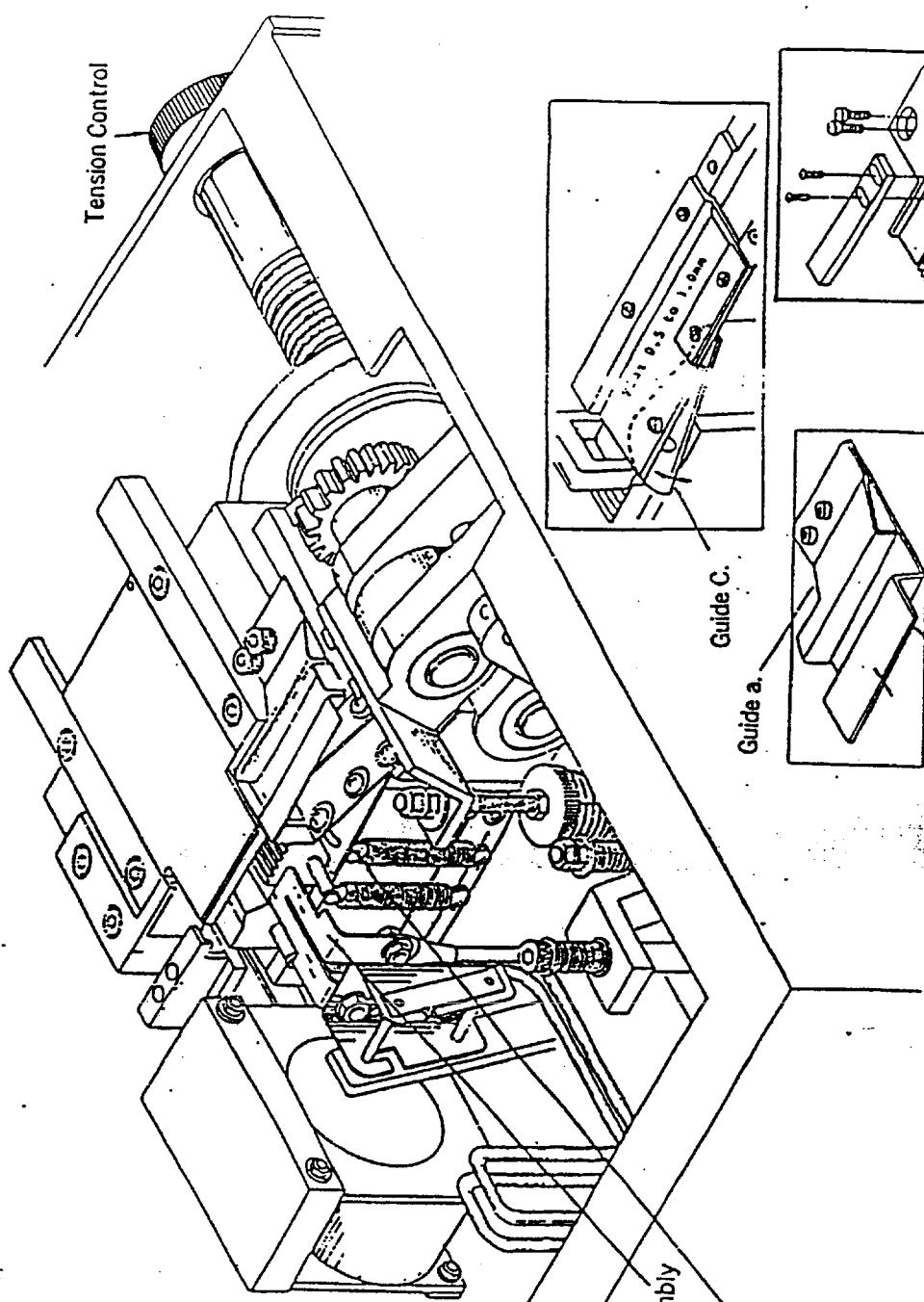
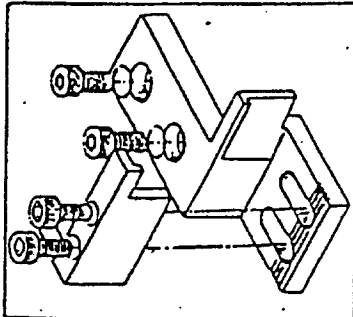

FIG. 8 STRAP THREADING DIAGRAM



B.

Guide C.

Guide a.

Guide b.

Heater assembly

Guide C.

SECTION 3 -PRINCIPLE OF OPERATION

GENERAL

This section is to introduce you the operational principles and the complete strapping process of instant heating system strapping machine. Basically, a complete strapping process includes three steps:

1. Tightening.
2. Welding.
3. Feeding.

For the following descriptions, please refer to Fig. 10.

MECHANICAL DESCRIPTION

TIGHTENING

See Fig.10(a),the correct path of the strap will be guided between two sets of rollers (tension & feed rollers), then through the passage of end gripper, plunger and holding gripper, and coming out of the table top cover.

Turn on the POWER and MOTOR switches. Press the FEED button to obtain the length required. Put the packaged on the top cover, encircle the strap around the package, see Fig.10(b),and insert the strap end into the slot. When the strap end touch the LIMIT SWITCH (Ls1), the tension rollers start to tighten the strap.

WELDING

When the strap is tightened by the tension rollers, the current of LS2 is turn on, then there has power supply to clutch, the cam shaft is in neutral position. Please refer to Fig.10(c) and circuit diagram on page 10.

If the cam shaft is not in neutral position, refer to Fig.10(d) the heater blade will go into the gap between straps, at this moment, the plunger moves upward and squeeze the heater blade, therefore, straps are heated.

See Fig.10(e) , when the heater blade returns to its original position the plunger keep squeezing the straps for about one second to cool the strap temperature down. After that, the plunger and holding gripping return to the original position simultaneously. Then, the top slide move back and complete the packaging.

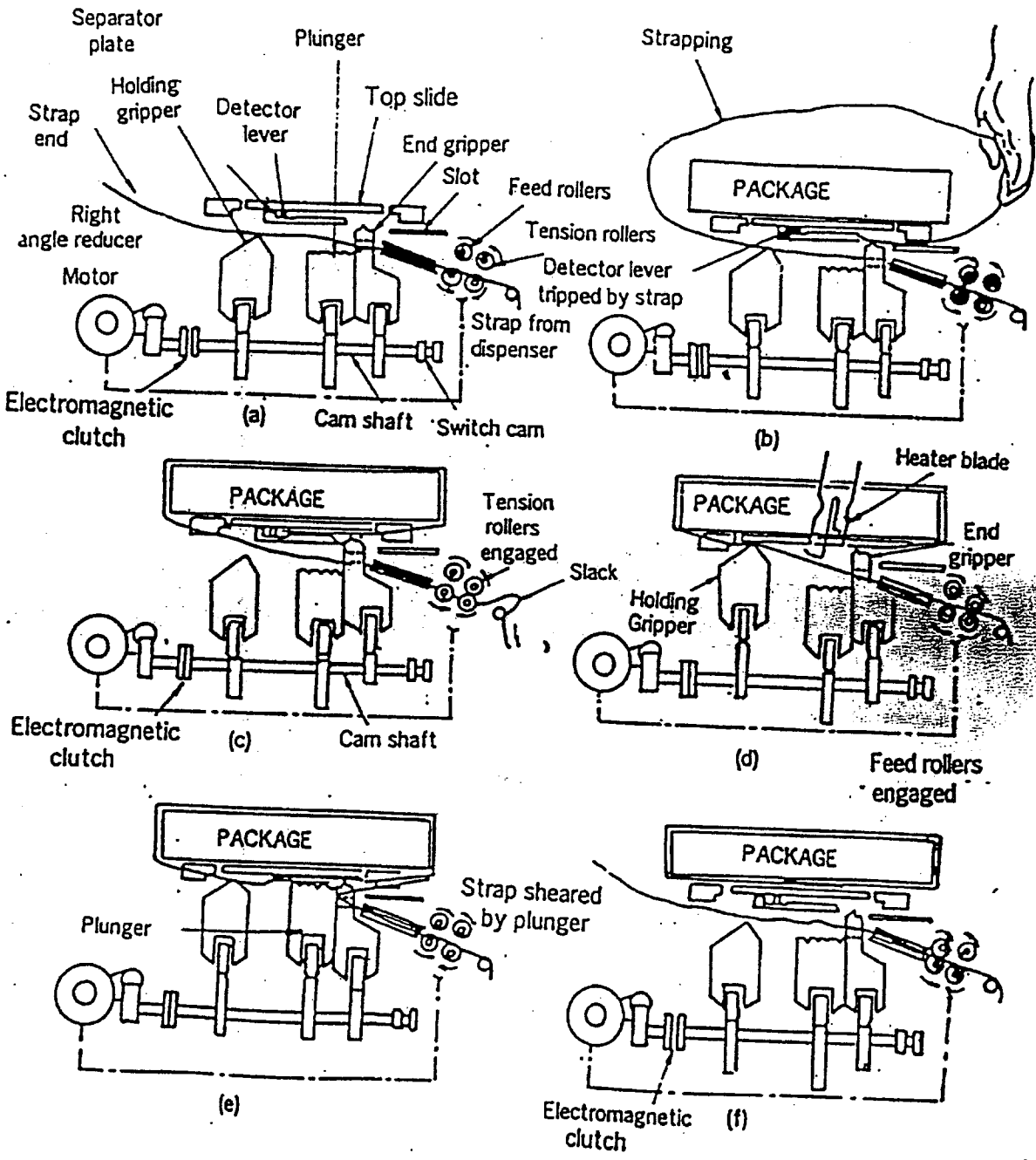

FIGURE 10. STRAPPING OPERATIONAL DETAILS

ELECTRICAL DESCRIPTION

A circuit diagram of the electric system is illustrated in page 36. Here we only state functions of each main switch on circuit.

- LS1:** Is located under TOP SLIDE, and keep open ordinarily. When packing, insert the tip of strap will touch ACTUATOR and provide the electrical current for the electromagentic clutch.
- LS2:** Place above tension trip arm assembly and is a switch of permanent OFF. When packing tightly, the tension trip arm moves upward to make it as power open switch and cut electrical current of electro-magnetic clutch.
- LS3:** Is a switch of permanent ON and place in the left outside of switch cam. When Ls1 gives power to the electromagnetic clutch, the cam shaft turns to make the convex part of switch cam touch ACTUATOR of LS4. Is helps LS1 to provide the power supply for electromagnetic clutch.
- LS4:** Is a switch of permanent OFF and is placed with the SWITCH CAM. It delays the time of plunger pressing the heated straps.
- LS5:** This switch is at inside of the switch of LS3 (Refer to page 13, figure 13). It is used to control the timer and is a switch of permanent OFF at neutral position.

SAFETY REQUISITIONS:

- 1) Do not remove the electric control box cover if not necessary.
- 2) Only trained engineerrs are allowed to open the electric box. While opening, be sure to pull the power plug off.
- 3) Do not remove the transformer cover under the machine.
- 4) There are safety switches on the top cover and left right doors, please replace them immediatley, if any one of the safety switches is broken down.

QUICK HEATING SYSTEM

Quick heating transformer is under the base plate. After the machine is turned on, it can reach the appropriate temperature in 30 seconds.

NOTE: Do not remove the protecting cover of the hot heater blade.

SECTION 4-ADJUSTMENTS AND CLERANCES

GENERAL

Instant heating system strapping machine is preadjusted to be ready for use. However, during the process being used, the clearance should be checked if necessary. Besides the tools supplied within the machine, no special tools or equipments are required.

TABLE 2. CLEARANCE AND ADJUSTMENTS

Clearances / Adjustment	Page No.
Top Slide	12
Tension Trip Arm Assembly	13
Switch Cam	13
Plunger and End Gripper	14
Tension Lever	14
Feed Rollers and Tension Rollers	15

TOP SLIDE

Adequate minimum clearance is required between the top slide and both left and right guides to insure top slide operating smoothly. To adjust and proceed as follows: (refer to Fig. 11)

1. Make sure that the right guide is mounted securely.
2. Loosen the mounting screw of the right guide.
3. Insert 0.05mm thick, 3mm wide, 130mm long shim between shoulder of top slide and right guide (see view A)
4. Place the right guide against top slide smoothly and tighten the mounting screws.
5. Remove shim.
6. Move the top slide forward and backward to check that whether the sliding is smooth or not.

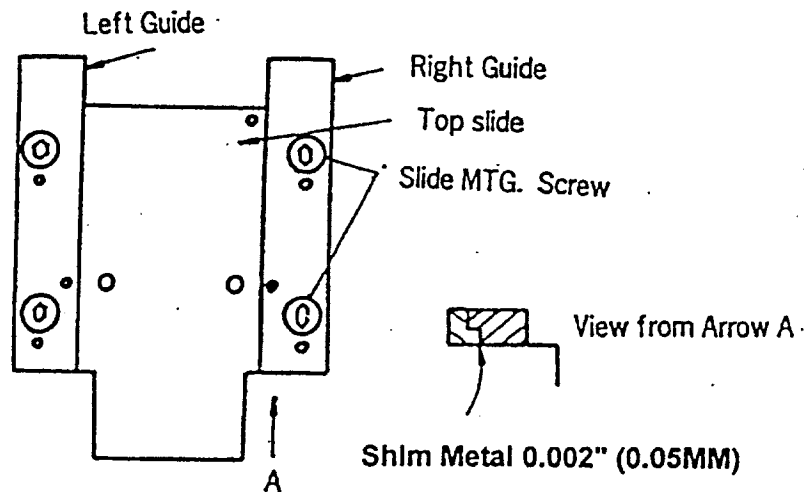

FIGURE11. TOP SLIDE CLEARANCE

TENSION TRIP ARM

When the tension trip is at neutral position the point B should be ungaped and point A should make the switch of LS2 at ON condition.

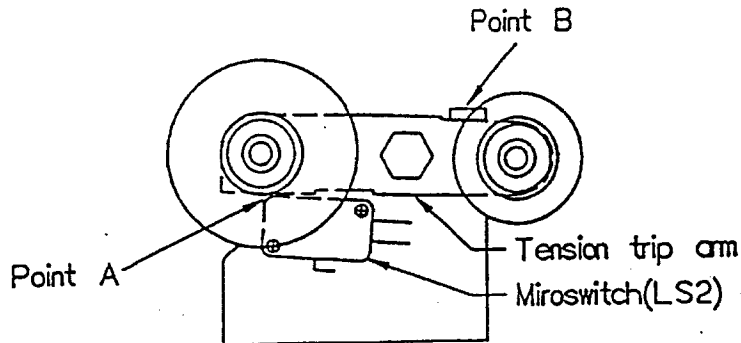
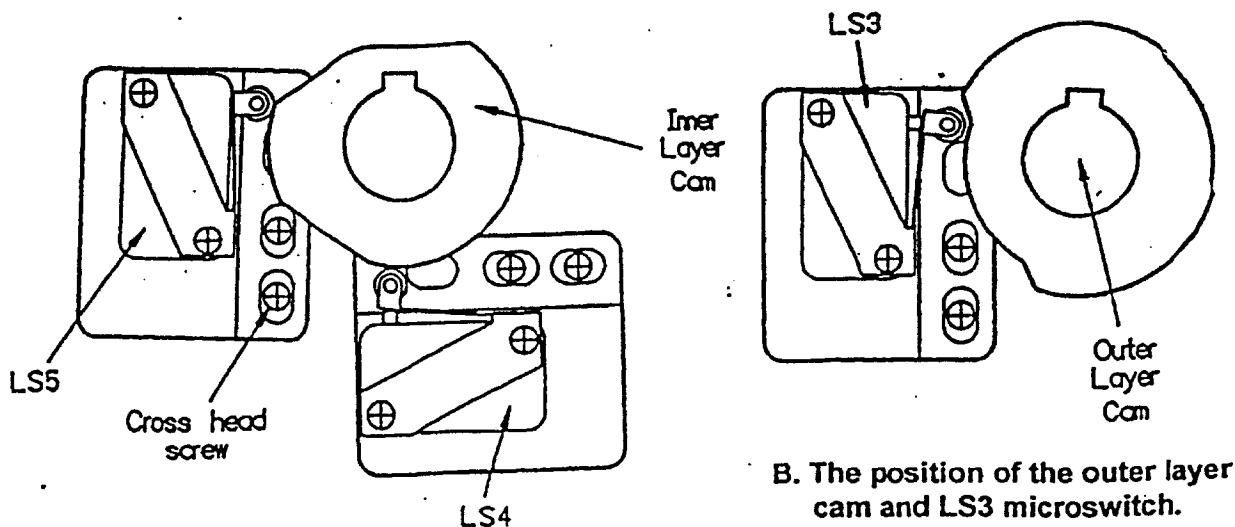

FIGURE 12. TENSION TRIP ARM ADJUSTMENT DETAILS

SWITCH CAM

When the machine is in neutral position, the switch cam must depress the microswitch actuator (LS5), while LS3 and LS4 can not be depressed. (refer to Fig.13) The switch cam has double layers which divided into inner layer and out layer. The inner layer controls LS5 & LS4 and the outer layer controls LS3. To adjust the clearance, proceed as follows:

1. Make sure that the machine is in neutral position.
1. Loosen the screw of the cam and screws in the microswitch.
3. Adjust LS4 as Figure 13. (A) shown.
4. Adjust LS3 as Figure 13. (B) shown.
5. Tighten screws in cam and microswitch.



A. The position of the inner cam and LS4, LS5 microswitch.

B. The position of the outer layer cam and LS3 microswitch.

FIGURE 13. CAM SWITCH ADJUSTMENT DETAILS

PLUNGER AND END GRIPPER

The clearance between the plunger and the end gripper will expand after long term of friction, the clearance would be too wide to cut the strap. Therefore proper adjustment is necessary. To adjust the clearance, proceed as follows:

1. Remove the top slide.
2. Use 4mm hexagon wrench to loose the screws of the L-type adjusting block, and push the block from left to right to make the plunger and the end gripper closer. The clearance should be more than 0.02mm.
3. Tighten the screws of the L-type adjusting block.

Note: If the cutting ability becomes poor, because of the dull plunger take out the plunger and change another cutting face of the plunger. Then install into sliding slot block by reverse order. (refer to Fig. 14)

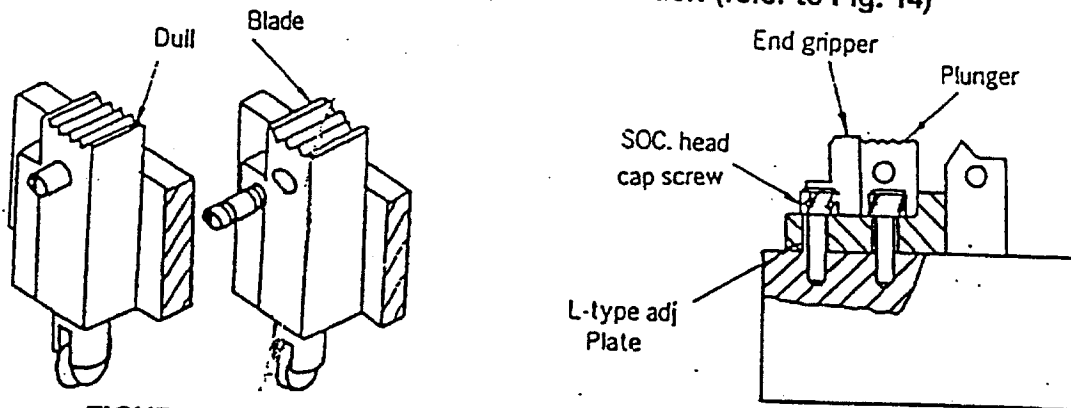

FIGURE 14 PLUNGER AND END GRIPPER CLEARANCE DETAILS

TENSION LEVER

The gap between tension lever will be adjusted at proper position before selling. If the operator wish to adjust the width of P.P. strap, please adjust the lock nut (1) and lock nut (2) (Refer to fig. 15-2) and make sure the tension lever is on accurated gap. Please use hand to let the (A) (B) (C) touching the top sliding plate (Refer to fig. 15-1) and the distance of (E) (F) & (D) does not allowed to have any gap (Refer to fig. 15-2)

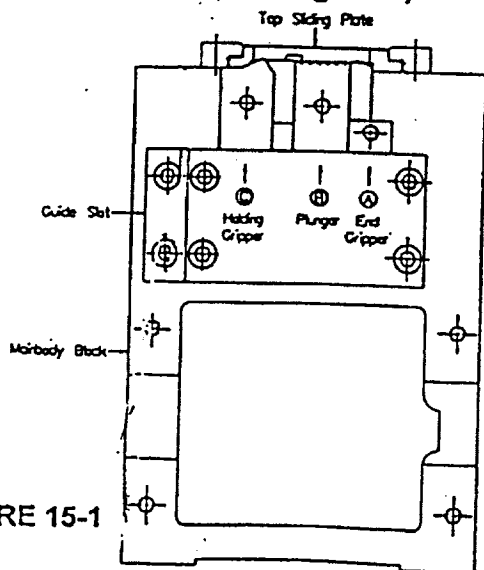

FIGURE 15-1

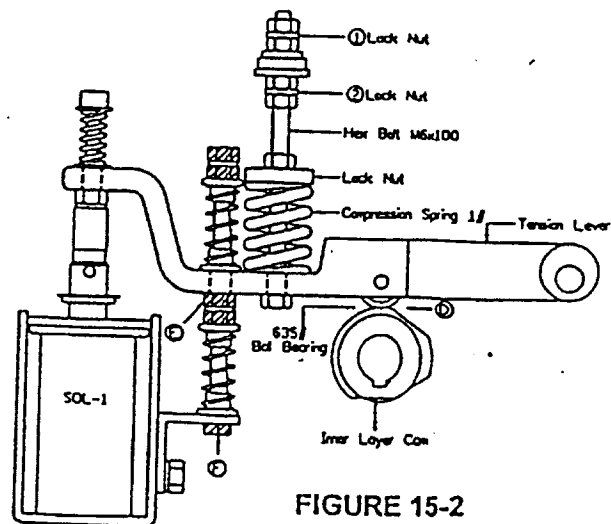

FIGURE 15-2

FIGURE 15 TENSION LEVER ADJUSTMENT DETAILS

1. Manually turn the rotor of the electromagnetic clutch of the speed reducer, and the speed reduction end of the reducer will move the CAM SHAFT while the largest easement face of the inner layer switch cam and the bearing of the tension are connected (in vertical position).
2. Loosen the locknuts A and B, and make the connecting point E of the bearing and the cam remaining no clearance.
3. Tighten the locknuts A and B, and make the connecting point D of the compression spring # 2 and the lever remaining no clearance. Thus the tension lever will be in level.

FEED ROLLERS AND TENSION ROLLERS

When the machine is in neutral position, the feed and tension rollers couldn't touch the strap. The gap between the feed or tension rollers should be kept in 1.0mm (generally, the thickness of the strap is 0.6 to 0.8mm). If the strap is too thick or too thin, please refer to Fig.16 and adjust as follows.

1. When the machine turns normally, the strap is going forward while the SOL 1 keeps still, this means that the clearance of the feed rollers is too narrow (smaller than 1mm). Please use two open wrenches(10mm) to adjust the locknuts 1 and 2 upward. Be sure to keep 0.5mm clearance between the holder arm and each locknut.
2. If the strapping cycle is completed, the strap stop moving forward while the SOL 1 acts. This indicates that the clearance of the tension rollers is too narrow. Adjust the locknuts 1 and 2 downward and to be sure to keep 0.5mm clearance between the holder arm and each locknut.

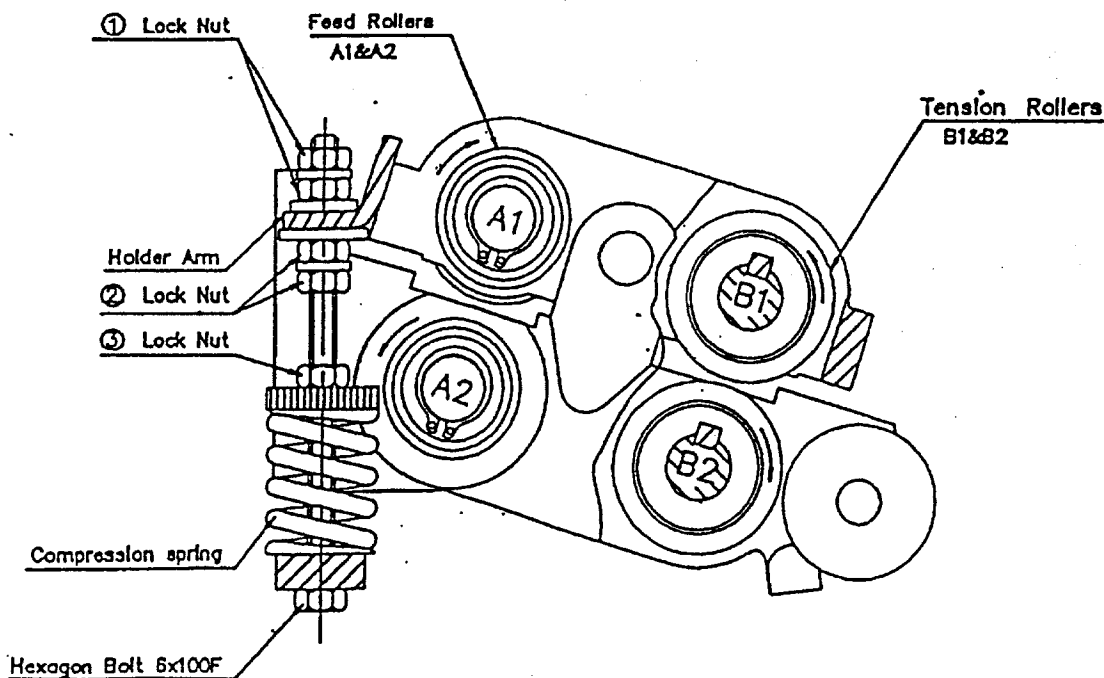

FIGURE16 ROLLER ASSEMBLY ADJUSTMENT DETAILS

- NOTE: 1. When adjusting, do not raise or lower the locknut too much each time.
2. After adjusting, make sure that the screwnuts are tightened.
3. The pressure of the compression spring is concerned about the effect of tightening. When adjusting, the tightness of the spring should match the tightness of the package. Do not adjust the compression spring too tight to prevent the bearing of the shaft from breaking down.

SPECIFICATIONS OF INSTALLATION THE P.P. STRAP (LOW TABLE TYPE)

The steps of installation:

1. Take the dispenser frame out of the machine. (Refer to drawing A)
2. To install the dispenser frame on the machine and use the screw to fixed it. (Refer to drawing B)
3. To install the P.P. strap on the dispenser frame, please notice the right direction of P.P. strap. (Refer to drawing C)

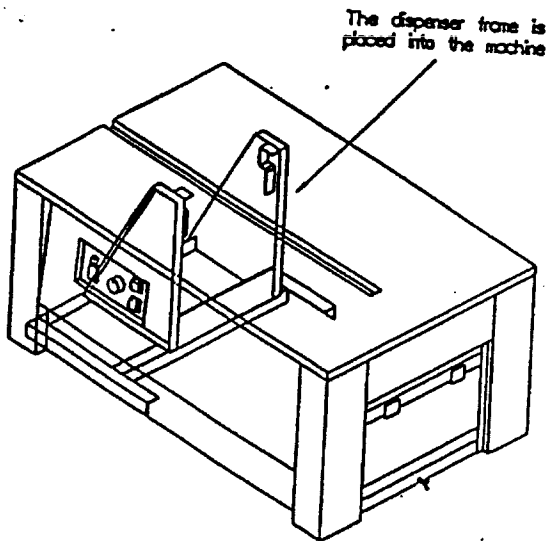

Drawing A

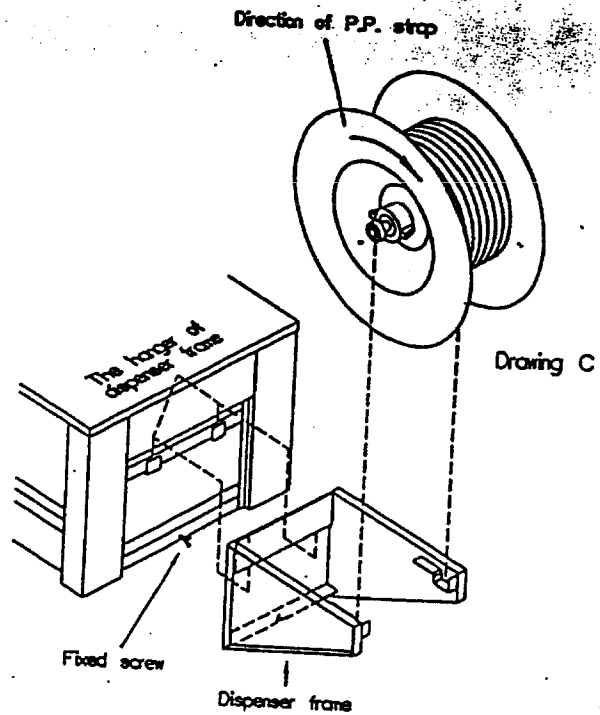

Drawing B

SECTION 5 LUBRICATION

Before oiling, its necessary to clean all parts of machine. If not, sand and strap chips will slide into clearance of the machine, amd will obstacle the movement of the mechanical parts.

TABLE 3. LUBRICATION GUIDE

PART NAME

Sleeve located on tension trip arm assembly.

WHERE TO APPLY

on edge of the sleeve, so that the oil can panetrate to the shoulder of screw.

Top slide, guide, plates, plunger, end gripper and holding gripper.(Fig.17)

Shown in Fig.17

Warm gear reducer, replace gear oil once a year.

Remove oil filling plung on the top,and drain plung in the bottom to drain oil. Replace drain plung and fill gear oil about 0.2 liter, replace the filling plug.

Three drops in each oil cup.

Drive motor at each 150 hours of operation.

NOTE: Do not lubricate the parts below:

1. Electromagnetic clutch.
2. Belts and pulley.
3. Rollers assembly.
4. Clutch disc.

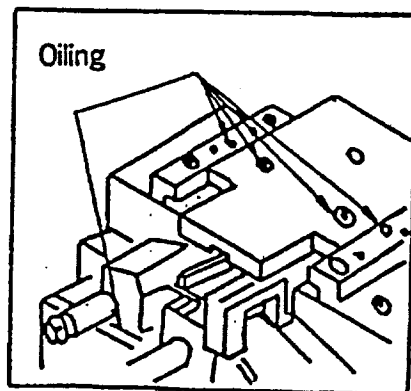

FIGURE17 TOP SLIDE, GUIDE PLATES, PLUNGER, END GRIPPER, AND HOLDING GRIPPER.

SECTION 6 MAINTENANCE

GENERAL

Maintenance is necessary for the machine under long-term of usage. Before maintenancing, pay attention to the following points:

1. Make sure that the power plug is disconnected, and the heater blade is cold.
2. If not necessary, do not loosen or adjust the nuts and screw which are painted red.
3. Keep flammable material and or solvents away from heater blade.

INSPECTION

Check the belts, and replace if the belts are worn out, too loose, or break down.

TROUBLESHOOTING

1. Symptom: Strap jams.

Cause: Strap buckles or wind.

Remedy: Please refer to Fig.16, page 15

- (1) Turn off the MOTOR switch.
- (2) Remove nut, flat washer and spring washer in part(1).
- (3) Remove 5mm setscrew.
- (4) Remove feed roller shaft.
- (5) Take away feed roller assembly.
- (6) Clean dirt in the guide by brush.
- (7) Cut off the buckled or wound strap.
- (8) According to order, (5)--(4)--(3)--(2), to install feed roller assembly.

2. Symptom: Strap does not feed.

Cause: SOL 1 keeps still(no magnetic force).

Remedy: The clearance of LS5 & switch cam need to be adjusted. or renew LS5 due to damage. (Refer to 13, Fig.13)

Symptom: After straping, the strap is not cut.

3-1. Cause: The round belt is broken or slip out.

Remedy: Renewal or remounting.

3-2. Cause: Poor connection of LS2.

Remedy: Renew LS2.

3-3. Cause: Poor clearance between LS3 & cam, or LS3 in poor condition.

Remedy: Refer to Fig.16 on page 15, adjust or renew.

4. **Symptom:** After strapping, the strap cannot be cut off.
Cause: The clearance between plunger end gripper is too large, or plunger is dull.
Remedy: Refer to Fig.14, page 14.
5. **Symptom:** Poor sealing of the strap.
 - 5-1. **Cause:** The temperature of the heater blade is too high.
Remedy: Lower the temperature of the heater blade.
(Refer to page 7, Welding)
 - 5-2. **Cause:** The temperature of the heater blade is too low.
Remedy: Rise the temperature of the heater blade.
(Refer to page 7, Welding)
 - 5-3. **Cause:** There is no current pass through the blade.
The fuse is broken down.
Remedy: Replace the 5A fuse located on the base plate.

Figure 18. COMPONENT LOCATIONS FRONT VIEW(740AU)

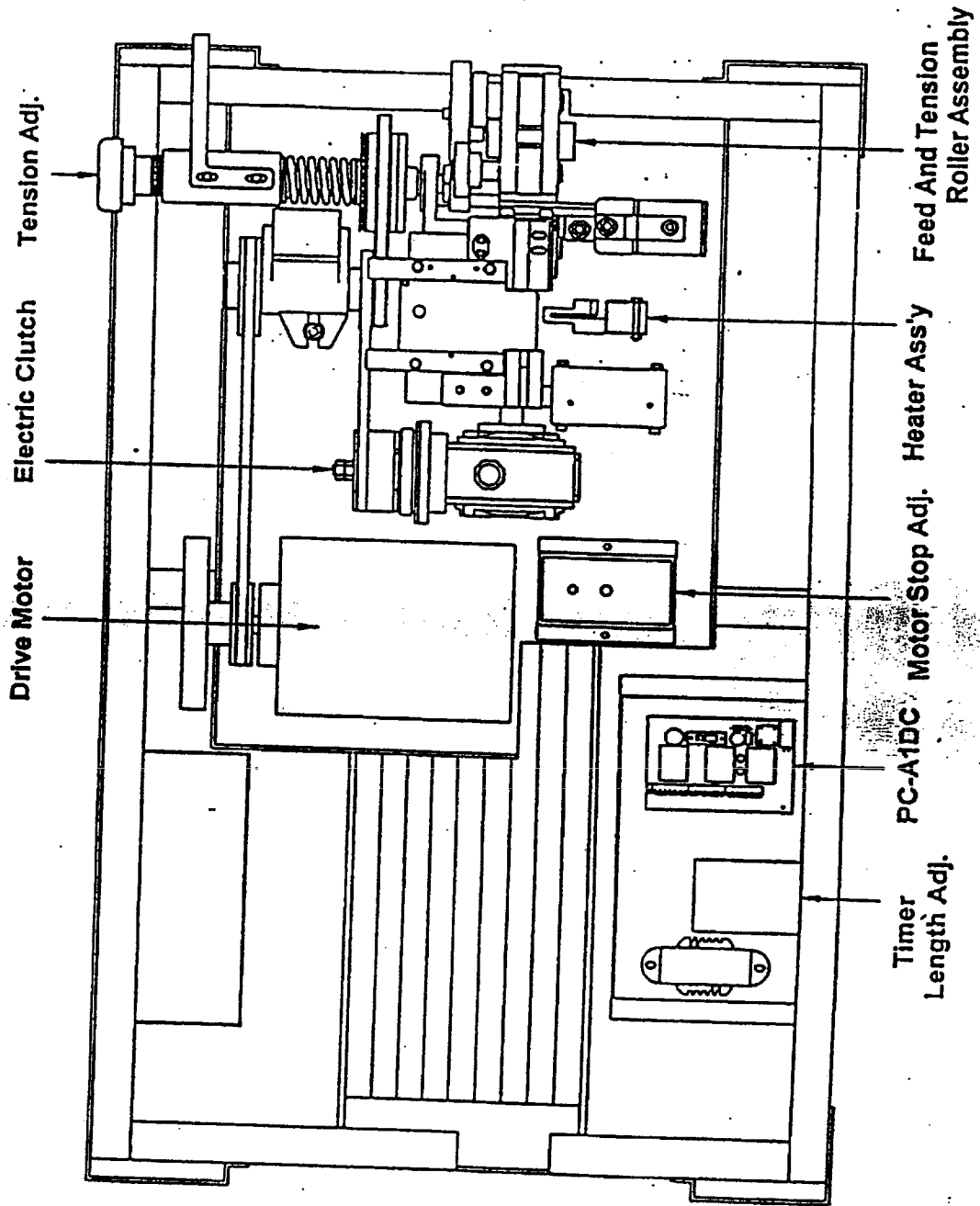

05/10/04

UNDERSEA SENSOR SYSTEM

S219790

S-2001 STRAPPING MACHINE

10. Electric circuit

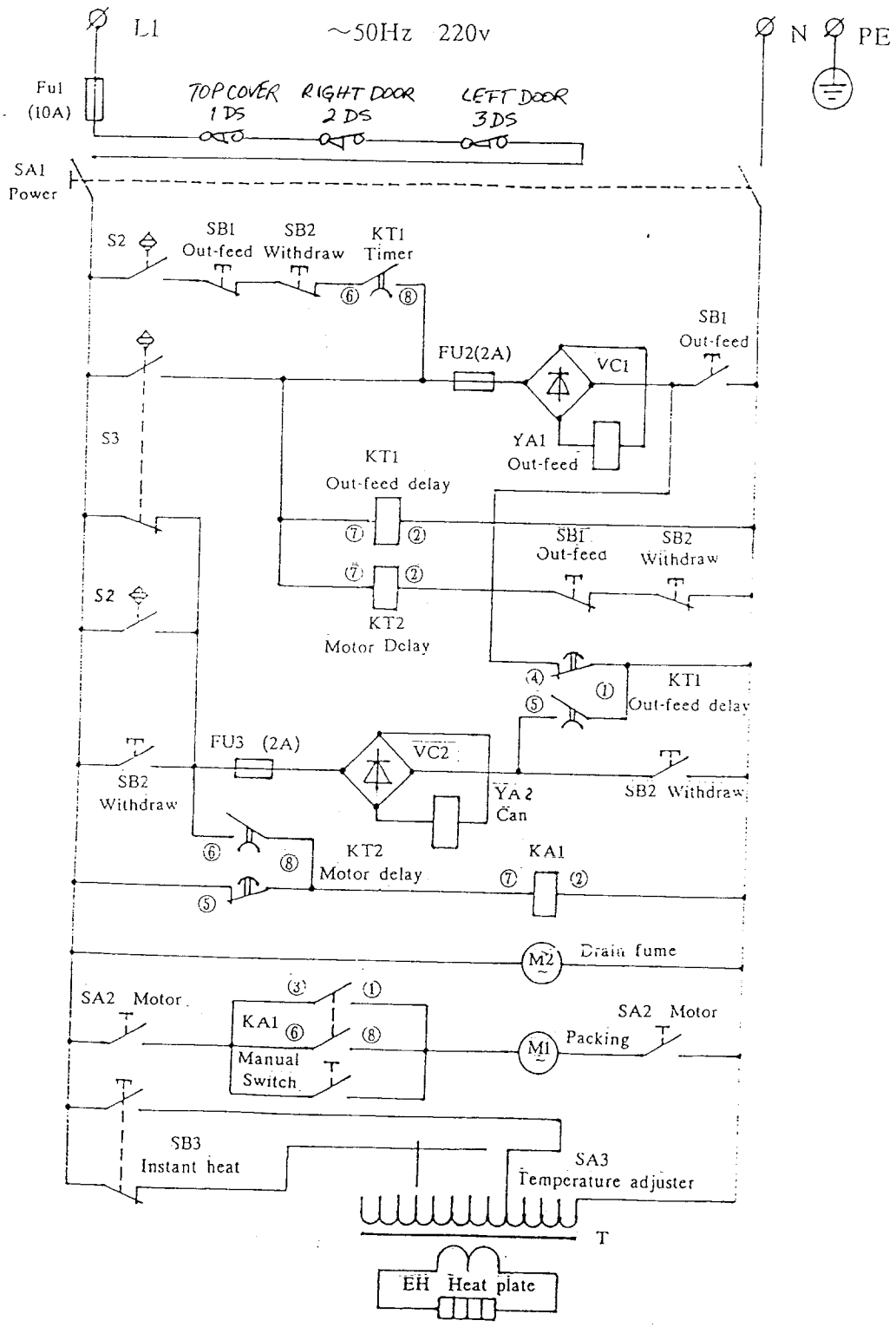

Fig. 14

1-3 DS--
 CPI switch BS111-18
 in E1092 body