

PRODUCT DATA SHEET

Product Description: Dead bolt door lock, double cylinder. ANSI Grade 3 dead bolt with a Kwikset KW 1 solid brass keyway. Escutcheons are brass with US11P venetian bronze finish. Internal mechanism fabricated from hardened steel with a zinc dichromate corrosion preventive finish. Key opens outside and inside. Ships with mounting hardware. Lock ships with mortise latch. Optional drive in latch (product #87396) and UL10C fire rated latch (product #87375) available.

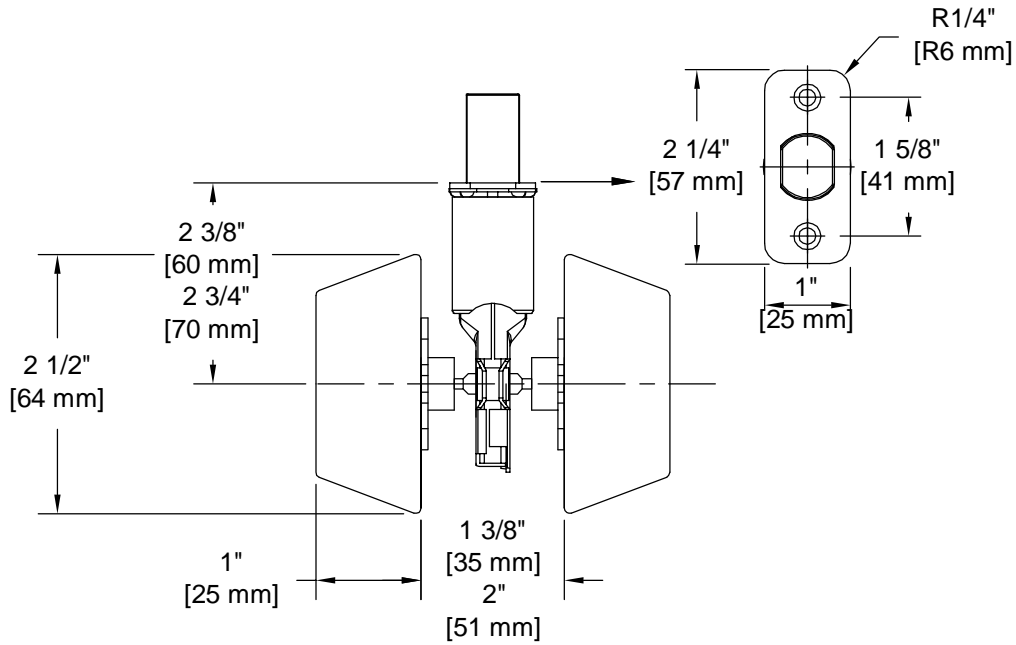

Door Prep: Cross Bore 2 1/8+, Edge Bore 1+, Mortise Latch Face 1+x 2 1/4+, Optional Drive In Latch 1" Diameter Drilled Hole

Latches: Ships With Mortise Latch As Shown Above. Optional Drive In Or UL10C Fire Rated Latches Available

Backset: Adjustable Latch to 2 3/8+ or 2 3/4+

Door Thickness: Fit all 1 3/8+ - 1 3/4+ Standard Doors

Cylinder: Brass with Nickel Plated Brass Keys and 5 Pin Tumbler Kwikset KW1 Keyway

Strike Plate: 2 1/4+ Full Lip Strike

Bolt: 1+ Throw

REKEY OPTIONAL



Overall Size: 2 1/2" W X 2 1/2" H X 1" D

Material: Brass Escutcheons, Hardened Steel Mechanism

Finish: US11P Venetian Bronze

Cross Reference

Manufacturer	Part Number



Description:

**Dead Bolt, Double
Cylinder, Premier Series,
KW1, ANSI Grade 3**

Part Number:

87351

Date

09/16

Rev.

04

Sheet 1 of 1