

PLEASE NOTE:

- 1) FOR SAFE OPERATION AND CONTINUED HIGH PERFORMANCE FROM THIS EQUIPMENT, INSPECTION AND MAINTENANCE MUST BE PERFORMED BEFORE EACH USE
- 2) USE OF THIS EQUIPMENT OTHER THAN INTENDED, MAY BE HAZARDOUS.
- 3) ALTERATION OR MODIFICATION OF EQUIPMENT MAY BE HAZARDOUS. FOR REPAIR OR REPLACEMENT, PLEASE CALL YOUR DEALER

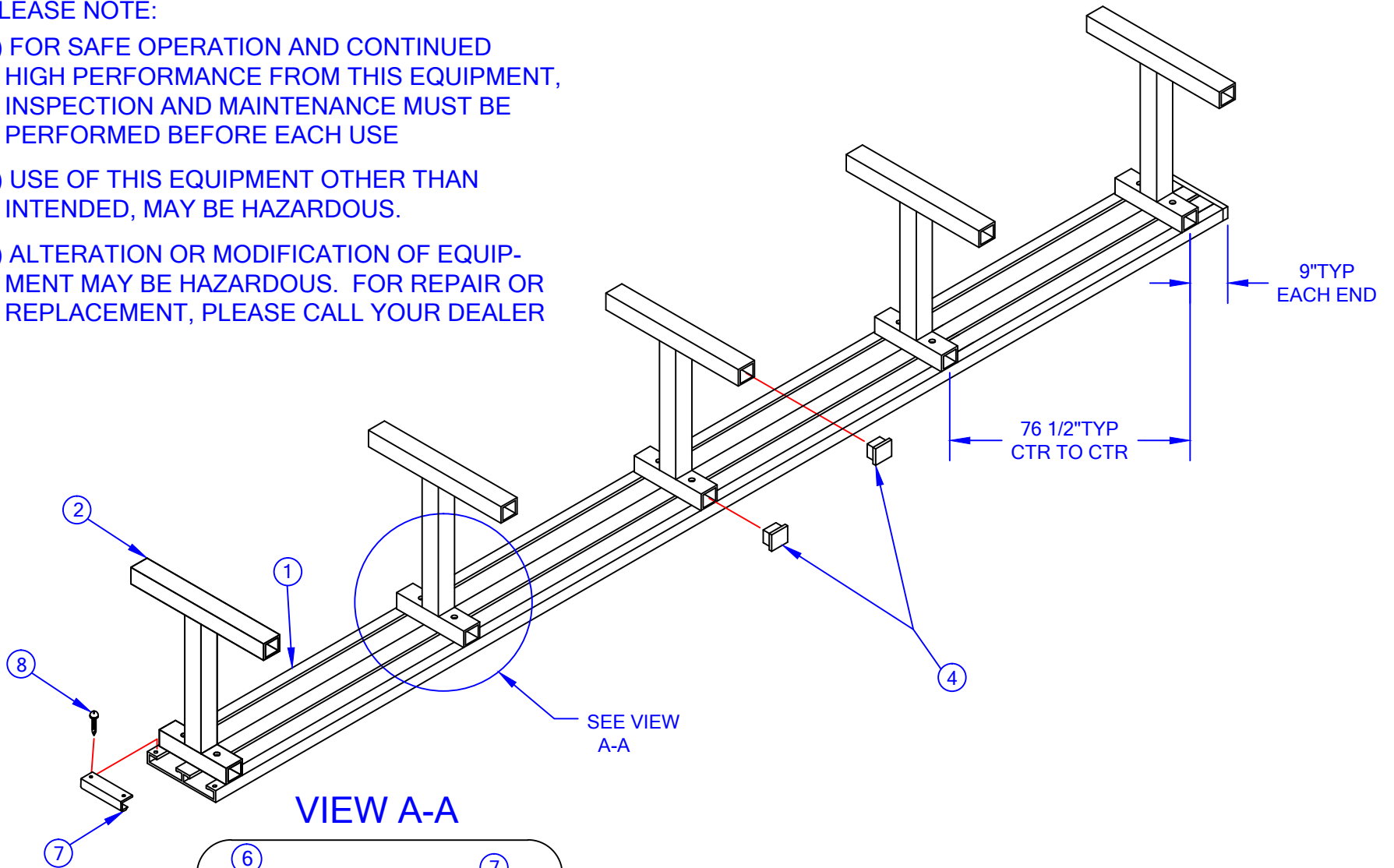

VIEW A-A

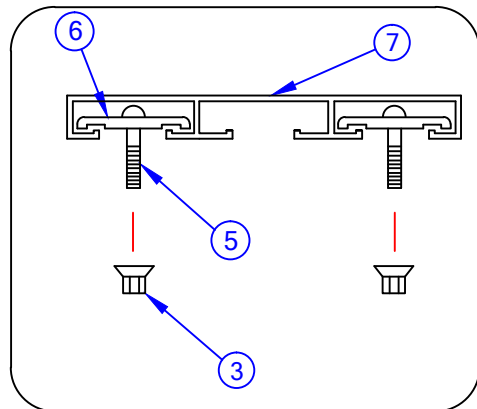

Jaypro Sports

976 Hartford Turnpike
Waterford, CT 06385 USA
(800)243-0533
(800)988-3363 Fax
www.jaypro.com

MODEL NO.:
PB-95

PRODUCT NAME:
27' PLAYERS BENCH

DRAWN BY: MT

EFFECTIVE DATE:
1/24/2011

JAYPRO SPORTS
27' PLAYER'S BENCH, PB-95
LIST OF MATERIALS

<u>PIECE #</u>	<u>PART #</u>	<u>DESCRIPTION</u>	<u>QTY.</u>
1	AR5111	SEAT PLANK 27'	1
2	PB751	BENCH LEG	5
3	HN5046	5/16" FLANGE NUT	10
4	EP0018	2" x 2" END CAP	20
5	HB5030	5/16"-18 x 3" CARRIAGE BOLT	10
6	AR5044	HOLD DOWN CLIP	10
7	AR5045A	END CAP	2
8	HS5035	#8 PAN HEAD SCREW x 1/2"	4

ASSEMBLY INSTRUCTIONS

TOOLS REQUIRED: PHILLIPS SCREWDRIVER BIT W/ ELECTRIC DRILL (1),
1/2" SOCKET WRENCH OR ADJUSTABLE WRENCH (1)

- 1) Slip the end caps (7) snugly onto each end of the plank (1). Using the electric drill, assemble a self-drilling screw (8) through the cap and into the flange of the plank. Two screws are required per end cap.
- 2) For easiest assembly, position seat plank (1) on a level raised surface such as a desk top, bleacher seat or work bench. Place the carriage bolt (5) and bolt clips (6) approximately into place within the slots of the plank. Note that the legs should be no more than 8" from the plank edge or 9" from edge to center leg.
- 3) Position the legs as shown and loosely assemble the hardware illustrated in detail 'a-a'. Do not fully tighten the hardware at this time. Level the bench and make sure the legs are adequately spaced apart. Tighten all fasteners fully.