



-- WALL MOUNTED ALUMINUM PLAYERS BENCH --
Installation Instructions

PBW-75 / PBW-75PC → 7-1/2 Ft Aluminum Players Bench.

PBW-15 / PBW-15PC → 15 Ft Aluminum Players Bench.

PBW-5 / PBW-5PC → 21 Ft Aluminum Players Bench.

PBW-95 / PBW-95PC → 27 Ft Aluminum Players Bench.

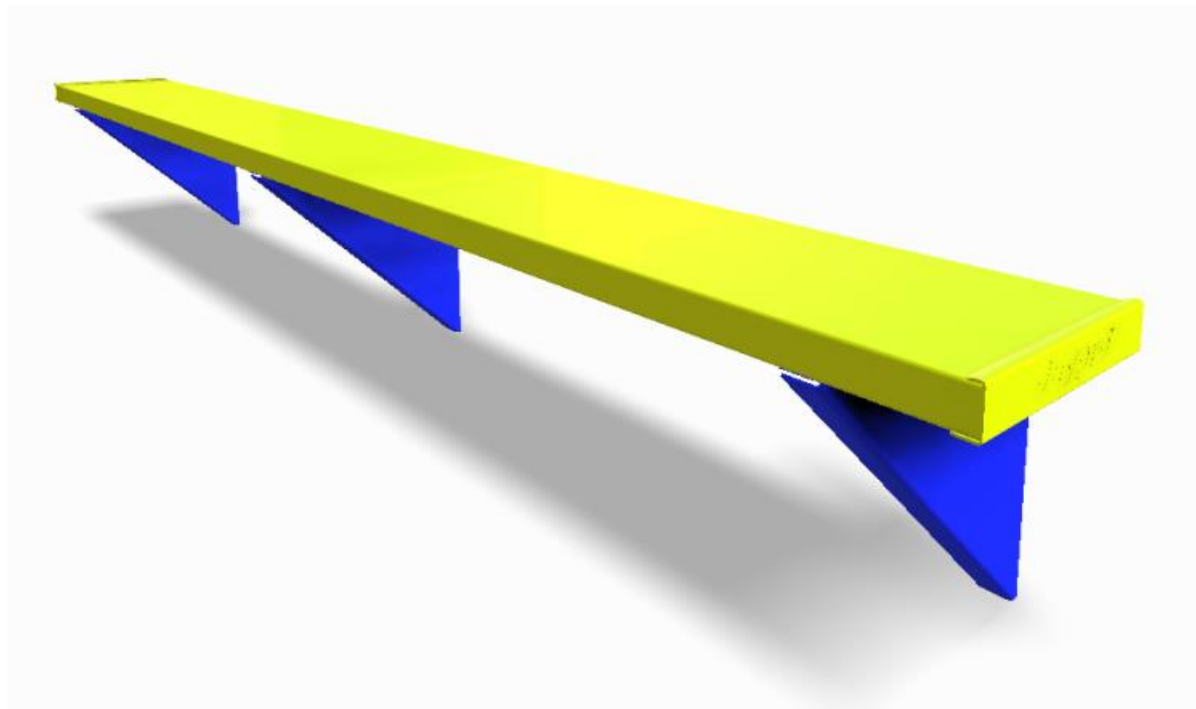

Call Jaypro Sports Equipment at 1-800-243-0533
during regular business hours for technical support.

www.jaypro.com

JAYPRO SPORTS
(WALL MOUNTED ALUMINUM PLAYERS BENCH)

ITEM	IMAGE	DESCRIPTION	PBW-75	PBW-15	PBW-5	PBW-95
1		WALL MOUNT BRACKET	3	3	5	5
2		STADIUM PLANK	1	1	1	1
3		5/16"-18 FLANGE NUT, SS	6	6	10	10
4		5/16-18 x 1 1/4 CARRIAGE BOLT, SS	6	6	10	10
5		5/16" BOLT CLIP	6	6	10	10
6		9 1/2" ALUMINUM SEAT PLANK END CAP	2	2	2	2
7		#8 x 1/2" PAN HEAD PHILIP SCREW SELF DRILL, SS	4	4	4	4
ITEM	IMAGE	DESCRIPTION	QTY	QTY	QTY	QTY

- Unpack all parts and check against parts list to ensure that all have been included.
- Inspect all parts for damage. Report any damages to the trucking company.
- Images shown are not to scale.
- PARTS LIST FOR SINGLE UNIT!

NOTE: 7/16" wall anchors are not supplied. Installer to size wall anchors per wall type.

IMPORTANT NOTICE:

- 1) BEFORE EACH USE CHECK EQUIPMENT FOR PROPER CONNECTING HARDWARE AND STRUCTURAL INTEGRITY. REPLACE DAMAGED OR MISSING HARDWARE IMMEDIATELY.
- 2) USE OF THIS EQUIPMENT OTHER THAN INTENDED, MAY BE HAZARDOUS.
- 3) ALTERATION OR MODIFICATION OF THIS EQUIPMENT MAY BE HAZARDOUS AND RESULT IN INJURY. FOR REPAIR OR REPLACEMENT, CONTACT YOUR DEALER OR JAYPRO SPORTS.
- 4) TO AVOID RISK OF INJURY ENSURE THAT THE SAFETY END CAPS ARE INSTALLED ON BOTH THE SEATING PLANK AND BACK PLANK.

TOOLS REQUIRED:

Electric Drill with Drill Bits

(1) ½” Socket Wrench and Box Wrench Set

(1) Rubber mallet

Wall Bracket Assembly:

1. Recommended height of finish seat height is 18” to finish floor.
2. Verify the correct orientation of the wall bracket, but noting the different hole pattern. Two holes on one side indicate the top. Three holes on one side indicate the back side to attach to the wall.
3. Each wall bracket gets three 7/16” wall anchors. This not provided installer to provide depending on your wall construction. Use “double dual expansion machine bolt wall anchor for solid concrete wall, including pre-cast concrete or filled block. For hollow walls, no-filled CMU (when anchoring into hollow block wall) use #1 type tumble toggle wall anchor. Sometimes the wall may be inappropriate to be attached to. If that is the case, a custom backing must be installed or relocate the wall bench elsewhere.
4. Mark your holes and spacing per Figure 1 & 2, before drilling wall bracket.

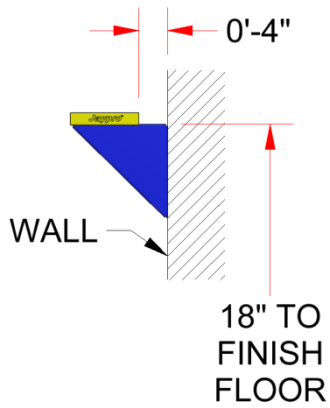

Figure 1

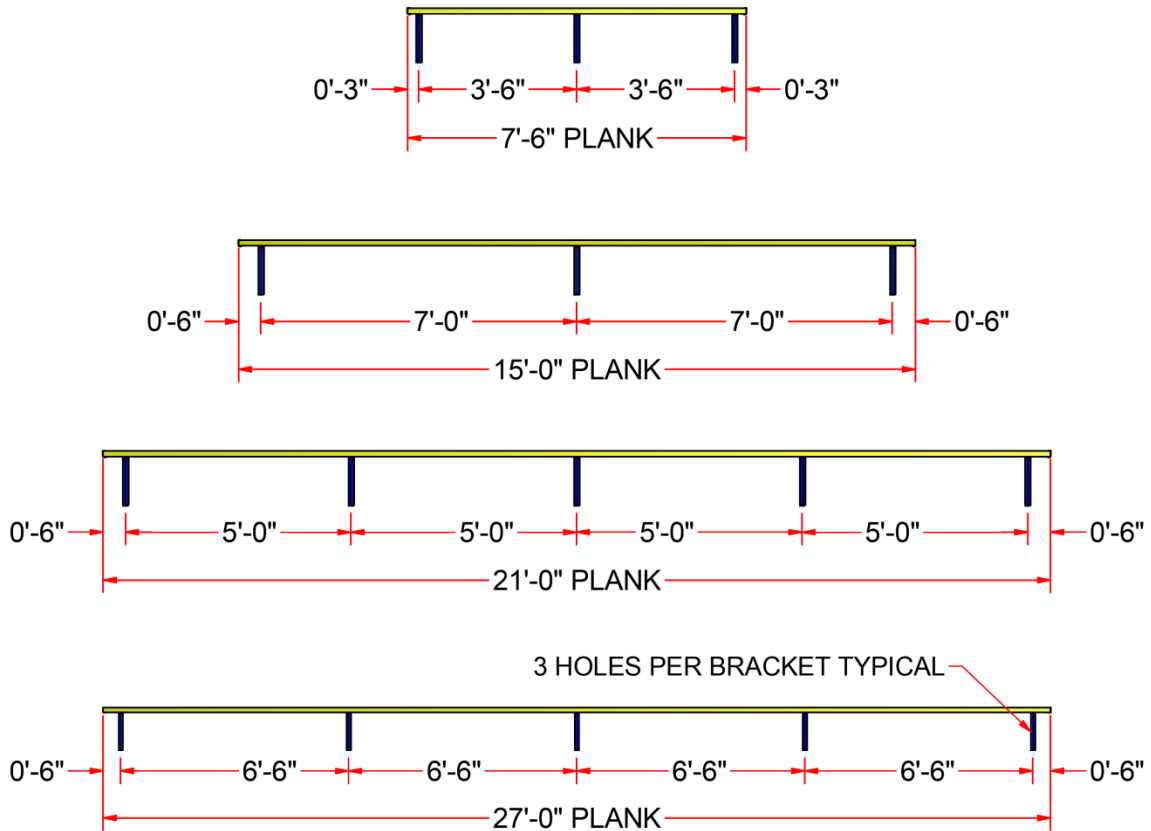

Figure 2

Plank Assembly:

1. The seating planks are assembled using 5/16" carriage bolt, bolt clip & flange nut (Figure 3).
2. Note that the planks end cap is factory installed. If yours comes bare, cap and drill two #8 pan head Philip screw into both ends of plank (Figure 4).

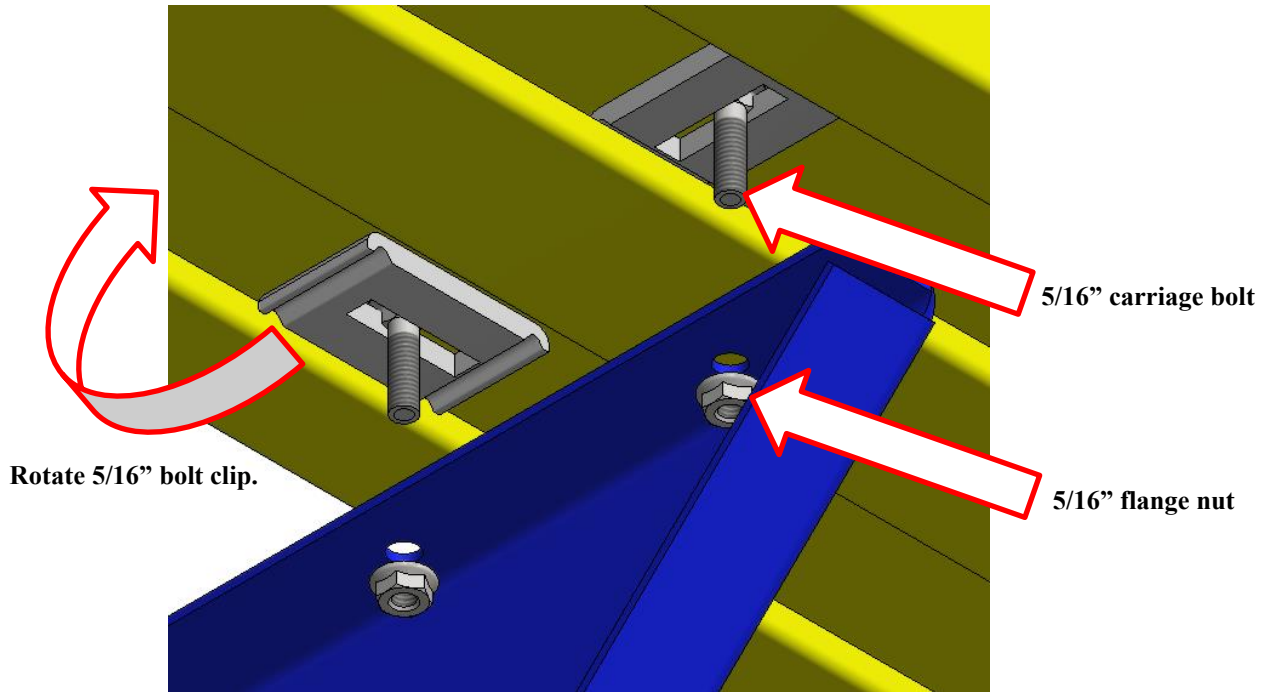

Figure 3

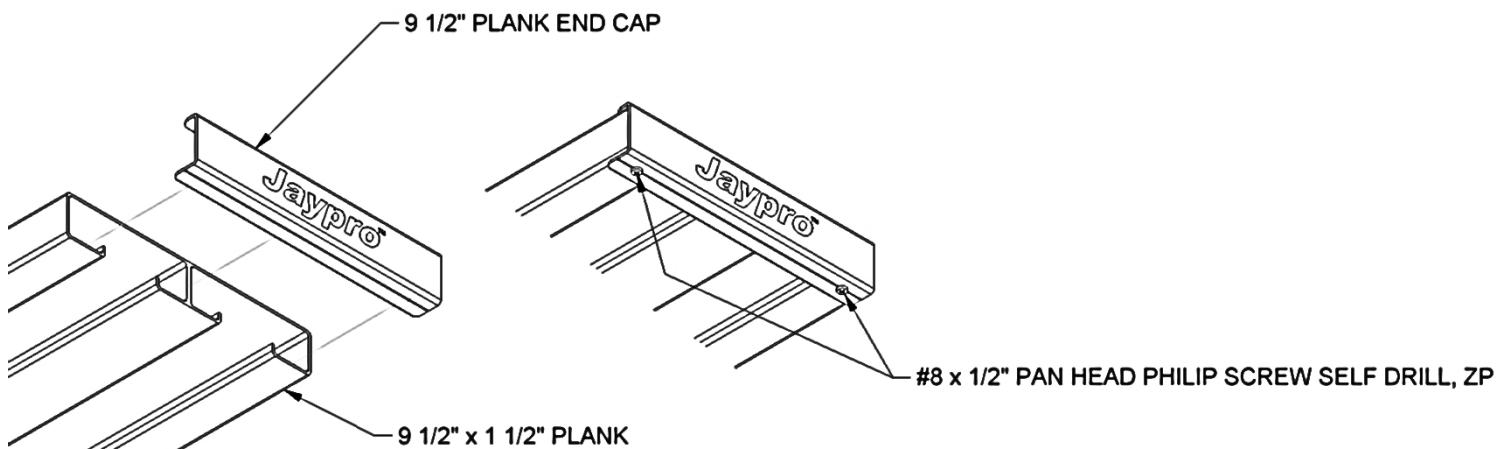

Figure 4