

TEKNA® ProLite BASECOAT/CLEARCOAT GRAVITY FEED SPRAY GUNS



Includes:

- HAV-555 air adjusting valve with digital gauge
- Gun wrench
- Color identification rings
- Additional fluid tips
- QuickClean™ coating

EPA and SCAQMD Approved

EPA Compliant. Approved in most HVLP areas.

Waterborne compatible when using a plastic or disposable cup system.

Order No.	Fluid Tips	Cup	Air Caps
703517*	1.3, 1.4, 1.5mm	Uncupped	TE20, HV30
703567*	1.2, 1.3, 1.4mm	Uncupped	TE10, TE20
703566	1.2, 1.3, 1.4mm	900cc Aluminum	TE10, TE20

* Uncupped guns include disposable cups adapter

TEKNA® ProLite Air Caps

HV30 air cap (HVLP)	Basecoats, clearcoats Air Cap Order/Model No. 703540 14.5-16.5 CFM @ 20-24 PSI inlet for HVLP approved areas	Air Cap Pattern 13-14"
TE10 air cap (HE)	Basecoats, low solids clearcoats Air Cap Order/Model No. 703538 7.5-11.0 CFM @ 20-35 PSI inlet	Air Cap Pattern 12-13"
TE20 air cap (HE)	Basecoats, high solids clearcoats Air Cap Order/Model No. 703539 9-12 CFM @ 16-26 PSI inlet	Air Cap Pattern 12-13"
Fluid Tips	1.2mm, 1.3mm, 1.4mm, 1.5mm	



Refer to Technical Bulletin: TB-1008

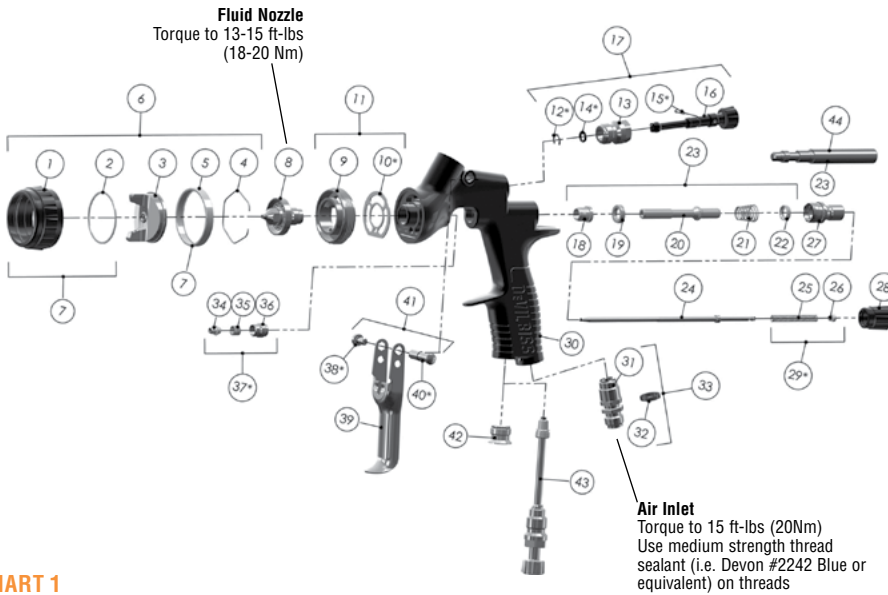

CHART 1
Air Cap Replacement Parts

Air Cap Order No.	Application	Air Cap No.	Recommended Inlet Pressure BAR/PSI	Air Flow LPM/SCFM
703540	Basecoats Clearcoats	HV30	1.4-1.6 bar 20-24 psi	411-467 LPM 14.5-16.5 CFM
703538	Basecoats, low solids clearcoats	TE10	1.4-2.4 bar 20-35 psi	212-311 LPM 7.5-11.0 CFM
703539	Basecoats, high solids clearcoats	TE20	1.1-1.8 bar 16-26 psi	255-340 LPM 9-12 CFM

CHART 2
Fluid Nozzles

Fluid Nozzle Order No.	No. on Fluid Nozzle	Tip Size (mm)
703521	PRO-200-12	1.2
703522	PRO-200-13	1.3
703523	PRO-200-14	1.4
703589	PRO-200-15	1.5

Ref #	Description	Part #	Qty
1	Air Cap Retaining Ring		1
2	Slip Ring		1
3	Air Cap		1
4	Air Cap Retaining Clip	191972	1
5	Retaining Ring Seal		1
6	Aircap & Ring	Chart 1	1
7	Air Cap Retaining Ring & Seals	702725	1
8	Fluid Nozzle	Chart 2	1
9	Spray head		1
*10	Spray head Seal	702726	1
11	Spray head kit	703529	1
*12	Circlip		1
13	Valve Body		1
*14	O Ring		1
*15	Spreader Valve Pin		1
16	Spreader Valve Adjusting Knob		1
17	Spreader Valve Assembly	702730	1
18	Front Valve Seal		1
19	Valve Seat		1
20	Spindle		1
21	Air Valve Spring		1
22	Rear Valve Seal		1
23	Air Valve Kit	703530	1
24	Fluid Needle	703531	1
25	Needle Spring		1
26	Spring Pad		1
27	Housing & Seal Kit	703532	1
28	Fluid Adjusting Knob	703533	1
*29	Needle Spring Kit	703534	1
30	Gunbody		1
31	Air Inlet		1
32	Colour ID Ring Kit (4 Colours)	702735	1
33	Air Inlet Kit	702734	1
34	Needle Packing		1
35	Packing Spring		1
36	Packing Nut		1
*37	Packing, Spring and Packing Nut Kit	702731	1
*38	Trigger Screw		1
39	Trigger		1
*40	Trigger Stud		1
41	Trigger Stud & Screw Kit	703535	1
42	Plug		1
43	Cheater Valve (optional)	702737	1
44	Air Valve Service Tool (only included in the Air Valve Kit 23)		1

SERVICE PARTS

Spray Gun repair kit (includes items marked *)	703536
Seal and Pin Kit, kit of 5 (items 12, 14 and 15)	192229

TEKNA® Pro BASECOAT/CLEARCOAT GRAVITY FEED SPRAY GUNS



Includes:

- Multiple air caps and nozzles
- HAV-555 digital air adjusting valve with gauge
- Gun wrench and color ID rings
- Full-size gun body

EPA Compliant.
Approved in most
HVLV areas.

EPA and
SCAQMD
Approved

Waterborne
Compatible

Waterborne compatible when using a plastic or disposable cup system.

Order No.	Fluid Tips	Cup	Air Caps
703582*	1.3, 1.4, & 1.5mm	Uncupped	TE20 & HV30
703581*	1.2, 1.3, & 1.4mm	Uncupped	TE10 & TE20
703580	1.2, 1.3, & 1.4mm	900cc Aluminum	TE10 & TE20

* Uncupped guns include disposable cups adapter

TEKNA® Pro Air Caps

TE10 air cap (HE)	Basecoats, low solids clearcoats Air Cap Order/Model No. 703538 7.5–11 CFM @ 20–35 PSI inlet	Air Cap Pattern 12-13"
TE20 air cap (HE)	Basecoats, high solids clearcoats Air Cap Order/Model No. 703539 9–12 CFM @ 16–26 PSI inlet	Air Cap Pattern 12-13"
HV30 air cap (HVLV)	Basecoats, clearcoats Air Cap Order/Model No. 703540 14.5–16.5 CFM @ 20–24 PSI inlet	Air Cap Pattern 13-14"
Fluid Tips	1.2mm, 1.3mm, 1.4mm, 1.5mm	



Refer to Technical Bulletin: TB-1012

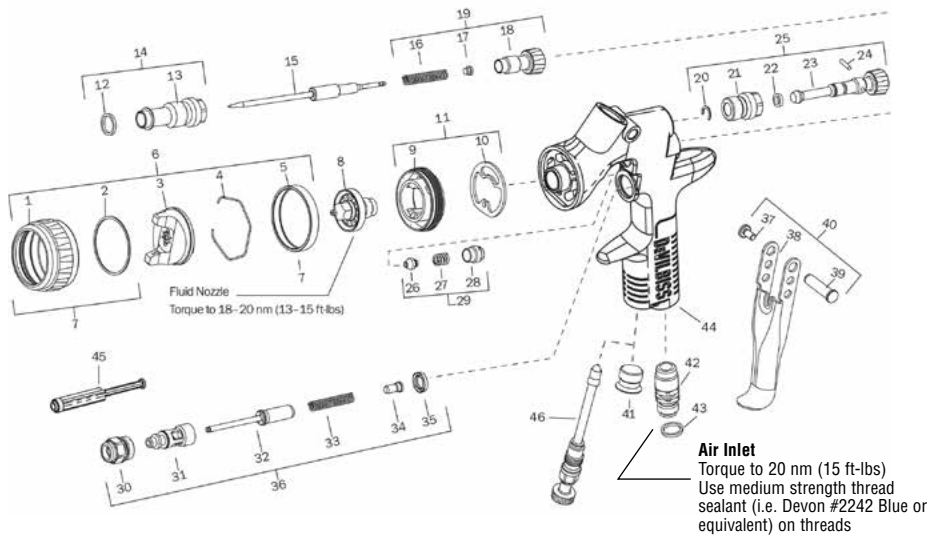

**CHART 1
Air Cap Replacement Parts**

Air Cap Order No.	Application	Air Cap No.	Recommended Inlet Pressure BAR/PSI	Air Flow LPM/SCFM
703540	Basecoats Clearcoats	HV30	1.4–1.6 bar 20–24 psi	411–467 LPM 14.5–16.5 CFM
703538	Basecoats, low solids clearcoats	TE10	1.4–2.4 bar 20–35 psi	212–311 LPM 7.5–11.0 CFM
703539	Basecoats, high solids clearcoats	TE20	1.1–1.8 bar 16–26 psi	255–340 LPM 9–12 CFM

**CHART 2
Fluid Nozzles**

Fluid Nozzle Order No.	No. on Fluid Nozzle	Tip Size (mm)
703521	PRO-200-12	1.2
703522	PRO-200-13	1.3
703523	PRO-200-14	1.4
703589	PRO-200-15	1.5

Wrench (10 & 14mm)	702740
Seal and Pin Kit, kit of 5 (items 20, 22 and 24)	192229

* The TEKNA Spray Gun Repair Kit (702736) contains all the parts indicated with an asterisk.

Ref #	Description	Part #	Qty
1	Air Cap Retaining Ring		1
2	Slip Ring		1
3	Air Cap		1
4	Air Cap Retaining Clip	191972	1
5	Retaining Ring Seal		1
6	Air Cap & Ring	Chart 1	1
7	Air Cap Retaining Ring & Seals	702725	1
8	Fluid Nozzle	Chart 2	1
9	Air Separator		1
*10	Air Separator Seal (kit of 2)	702726	1
11	Air Separator & Seal Kit	703529	1
*12	Body Bushing Gasket		1
13	Body Bushing		1
14	Body Bushing & Gasket	702728	1
15	Fluid Needle	Chart 2	1
*16	Needle Spring		1
*17	Needle Spring Pad		1
18	Fluid Adjusting Knob		1
19	Fluid Adjusting Knob, Spring, & Pad Kit	702729	1
*20	Retaining Clip		1
21	Spreader Valve Body		1
*22	O-ring		1
23	Spreader Valve Adjusting Knob		1
*24	Spreader Valve Pin		1
25	Spreader Valve Assembly	702730	1
*26	Needle Packing		1
*27	Packing Spring		1
*28	Packing Nut		1
29	Packing, Spring & Packing Nut Kit	702731	1
30	Air Valve Body		1
31	Air Valve Cage		1
32	Air Valve Poppet		1
33	Air Valve Spring		1
34	Air Valve Spring Pad		1
35	Air Valve Seal Seal (Kit of 5)	803307	1
36	Air Valve Assembly	702732	1
*37	Trigger Stud Screw (T20 Star)		1
38	Trigger		1
*39	Trigger Stud		1
40	Trigger, Stud & Screw Kit	702733	1
41	Plug		1
42	Air Inlet	702734	1
43	Colour ID Ring Kit (4 Colours)	702735	1
44	Gun Body		1
45	Air Valve Service Tool (only included with Air Valve Assembly 36)		1
46	Air Adjusting Valve (optional)	702737	1