

DEVILBISS[®]

**DAD-503 (130089)
AIR STATION WITH DESICCANT**

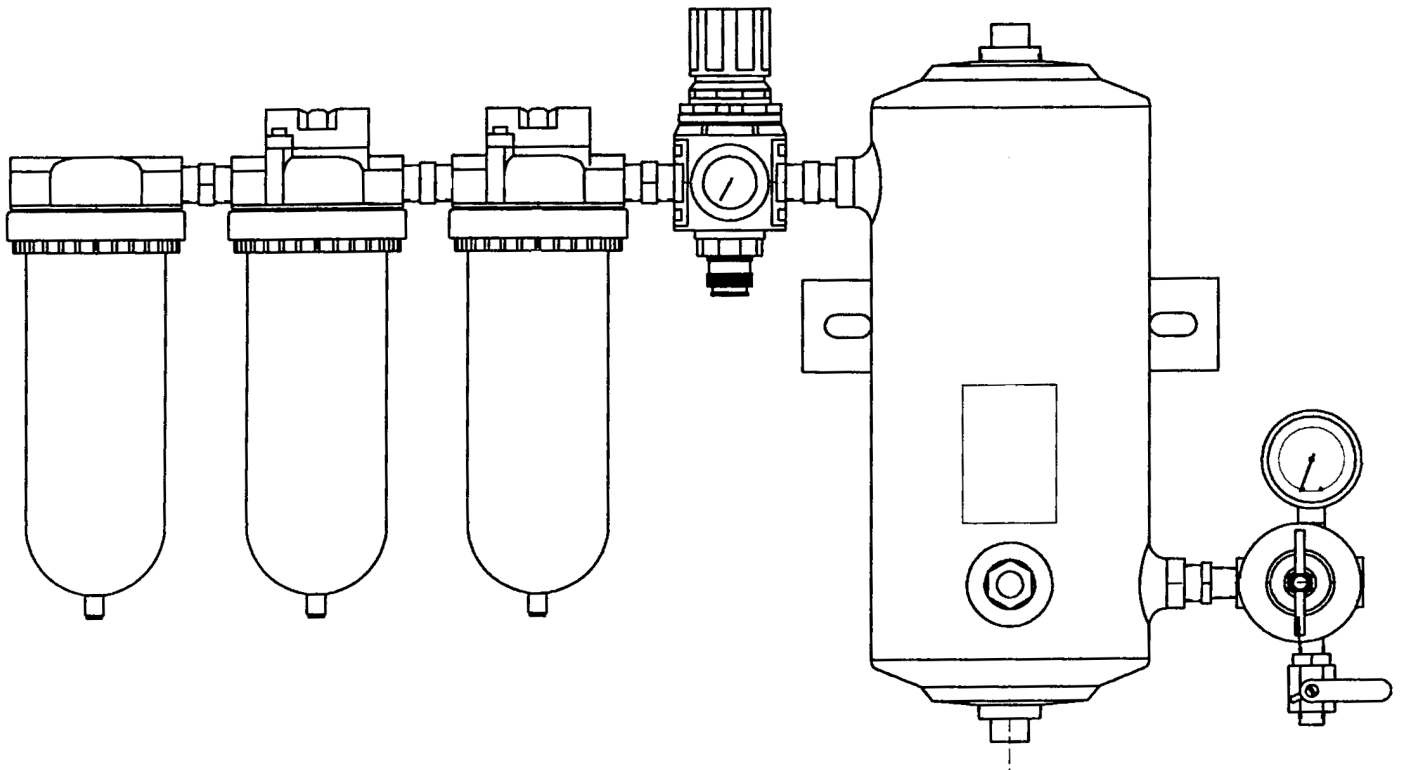

IMPORTANT! DO NOT DESTROY

It is the Customer's responsibility to have all operators and service personnel read and understand this manual.
Contact your local DeVilbiss representative for additional copies of this manual.

READ ALL INSTRUCTIONS BEFORE OPERATING THIS DEVILBISS PRODUCT.

SAFETY PRECAUTIONS

This manual contains important information that all users must know and understand before using the equipment. This information relates to **USER SAFETY and PREVENTING EQUIPMENT PROBLEMS.**

To help you recognize this information, we use the following terms to draw your attention to certain equipment labels and portions of this manual. Please pay special attention to any label or information that is highlighted by one of these terms:

WARNING

Important information to alert you to a situation that might cause serious injury if instructions are not followed.

CAUTION

Important information that tells how to prevent damage to equipment, or how to avoid a situation that might cause minor injury.

Note

Information that you should pay special attention to.



WARNING

Risk of injury. Do not place unit in service without metal bowl guard installed. Filter units are sold only with metal bowl guards. To minimize the danger of flying fragments in the event of plastic bowl failure, guard must not be removed. If the unit is in service without the metal bowl guard installed, manufacturer's warranties are void and the manufacturer assumes no responsibility for any resulting loss. If unit has been in service and does not have a metal bowl guard, order one and install before placing back in service.

CAUTION

Certain compressor oils, cleaning agents and solvents may attack the plastic and rubber components used in the construction of this product. This product should not be used in conjunction with or in the vicinity of these materials. Read and follow material labels carefully. Please consult DeVilbiss if in doubt.

INSTALLATION - AIR STATION



WARNING

Risk of explosion and injury. Release all air pressure from system before servicing system. Be sure to read and understand all Service Bulletins on the separate components before using the system. Use only specified DeVilbiss parts.

CAUTION

Risk of equipment damage! Do not install your air station where it is subjected to sudden depressurization cycles exceeding 20 PSIG. Quick relieving air solenoid valves, typical in some spray booths, will eventually fail pressure gauges and filters.

To minimize sudden depressurization effect, replace the existing solenoid with a "slow closing solenoid valve". (One source: Automatic Switch Co). Or, install an air adjusting valve at the existing solenoid valve outlet.

For ease of installation and maintenance, attach the assembled air station to the main air line using a pipe union, (not included).

1. Be sure to read all "**Warnings**" and "**Cautions**" in this manual and component manuals on the unit before installation or using this equipment.
2. Install air station system as close as possible to the point where the air is being used. Use enclosed mounting bracket to support Air Station.
3. Install main air supply shut off valve upstream of air drying system to allow maintenance to the unit.
4. Install unit with air flow through filter in direction of arrow on top of filters.
5. Minimum 3/4" NPT piping is recommended. Avoid using fittings, couplings, etc. that restrict air flow.
6. **Maximum inlet pressure and operating temperature is: 150 PSIG and 120° F (48.9 C)**
7. Three 6' lengths of vinyl tubing are shipped loose with the system. Slide over drains which protrude from bottom of the filters. Place the other end of vinyl tubing into appropriate receptacle. Prevent vinyl tubing from becoming kinked which would prevent free movement of liquids discharged from the automatic or manual drain.
8. An optional manual drain HAF-11) can be installed in place of the automatic drains.

IT IS THE RESPONSIBILITY OF THE EMPLOYER TO PROVIDE THIS INFORMATION TO THE OPERATOR OF THE EQUIPMENT. FOR FURTHER SAFETY INFORMATION REGARDING THIS EQUIPMENT, SEE THE GENERAL EQUIPMENT SAFETY BOOKLET (77-5300).

DAD-503 (130089) AIR STATION WITH DESICCANT

IMPORTANT: Read and follow all **INSTRUCTIONS** and **SAFETY PRECAUTIONS** before installing, operating or maintaining this equipment. Keep this manual for future reference.

DESCRIPTION

The DAD-503 is designed to be a point of use system. It is capable of removing dirt, water, oil and water vapor hydrocarbons and odors from compressed air. It consists of a filter separator, coalescing filter, charcoal filter, flow thru regulator, desiccant dryer, air regulator, and main air supply shut off valve.

A clean filtered supply of air must be provided for use with a supplied air respirator. In addition, air for spray operations passes through the desiccant filled tank that removes any remaining water vapor to a -40° F Dew Point, providing the ultimate air supply for spray finish applications.

SPECIFICATIONS

Air Filter (Separator):

Air Inlet	1/2" NPT(F)
Air Outlet	1/2" NPT(F)
Air Flow Capacity	100 CFM
Maximum Operating Press.	150 PSIG (10.3 Bar)
Maximum Temperature	150° F (65.6°C)
Automatic Mechanical Drain Filter	Supplied 5 micron

Coalescing Filter:

Air Inlet	1/2" NPT(F)
Air Outlet	1/2" NPT(F)
Air Flow Capacity	55 CFM
Maximum Operating Press.	150 PSIG (10.3 Bar)
Maximum Temperature	150° F (65.6°C)
Automatic Mechanical Drain	Standard
Pressure Differential Ind.	Standard
Filter	0.01 Micron

Charcoal Filter:

Air Inlet	1/2" NPT(F)
Air Outlet	1/2" NPT(F)
Air Flow Capacity	75 CFM
Maximum Operating Pressure	150 PSIG (10.3 Bar)
Maximum Temperature	150° F (65.6°C)
Manual Mechanical Drain	Standard
Pressure Differential Indicator	Standard
Aerosol Filter	.003 ppm./wt.
Particulate Filter	3.0 micron

Flow Thru Regulator:

Flow Thru Ports	1/2" NPT(F)
Regulated Ports	1/4" NPT(F)
Air Flow Capacity(regulated) with 100 PSI Inlet	28 CFM @ 60 PSI
Maximum Inlet Pressure	300 PSIG
Regulated Pressure	0-125 PSIG
Maximum Temperature	175° F (79.4°C)

Desiccant Dryer:

Air Inlet	1/2" NPT(F)
Air Outlet	1/2" NPT(F)
Air Flow Capacity	25 CFM
Maximum Operating Pressure	150 PSIG (10.3 Bar)
Maximum Temperature	150° F (65.6°C)
Humidity Indicator	Standard
Water Vapor Removal	-40° F Dew Point

Tool Air Regulator:

Air Inlet	3/8" NPT(F)
Air Outlet	1/4" NPT(F) (3 ea.)
Air Flow	60 CFM
Maximum Operating Pressure	150 PSIG (10.3 Bar)
Maximum Temperature	120° F (48.9°C)

VA-595 Main Air Supply Shut Off Valve:

Air Inlet and Air Outlet	1/2" NPT(M)
Maximum Operating Pressure	175 PSIG (12.0 Bar)

BREATHING AIR REQUIREMENTS

Supplied breathing air, as defined by OSHA 29 CFR 1910.134i and NIOSH 42 CFR 84.141, **MUST** meet or exceed the following requirements for Type 1-Grade D breathable air, as defined in Compressed Gas Association (CGA-G7-1-1997):

Oxygen = 19.5-23.5% (Typical atmospheric levels)

Oil (condensed) = 5 mg/m (milligrams per cubic meter) maximum

Carbon Monoxide (CO) = 10 ppm (parts per million) max.

Carbon Dioxide (CO₂) = 1000 ppm (parts per million) max. (Typical atmospheric levels)

Odor = The presence of a pronounced odor should render the air as unsatisfactory

It is up to the employer to assure that the air compressor is properly maintained, that the air compressor intake is located in a clean contaminate free location and that the air compressor is drawing in typical atmospheric air, meeting all of the national and local requirements for breathing air.

This filter unit does not remove or filter Carbon Monoxide (CO). It is up to the employer to ensure that the level of CO does not exceed the maximum national or local allowed level. The recommended method to assure that the CO level is not exceeded is to install a carbon monoxide monitor and alarm.

This filter unit will only remove particulate matter, water, oil and odor. This filter unit will meet the particulate matter, oil and odor requirements of Type 1-Grade D Breathable Air and Compressed Breathing Air, CSA-Z180.1 when:

- The filter unit is connected to a compressed air source:
 - The compressor is properly maintained
 - The air compressor intake is located in a clean contaminate free location
 - The air compressor is drawing in typical atmospheric air, meeting all of the national and local requirements for breathing air
- The filters are properly maintained
- A properly operating CO monitor is installed



WARNING

Risk of explosion or fire. Improper use can cause personal injury.

• **This product is designed and intended for use in industrial compressed air systems only. Do not use for liquids or gasses other than air.**

• **Do not use where pressure or temperature can exceed rated operating conditions (see specifications).**

• **Regulated outlet pressure must never be set higher than the maximum operating pressure of the downstream air tool or equipment. An outlet pressure gauge should always be used.**



WARNING

Risk of illness or death. Carbon monoxide can cause nausea, fainting or death. Stop using if carbon monoxide is present. This unit does not remove carbon monoxide. A carbon monoxide monitor should be incorporated into your air supply line to warn of the presence of carbon monoxide.

DAD-503 (130089) AIR STATION WITH DESICCANT

Figure 2 – DAD-503 Air Station

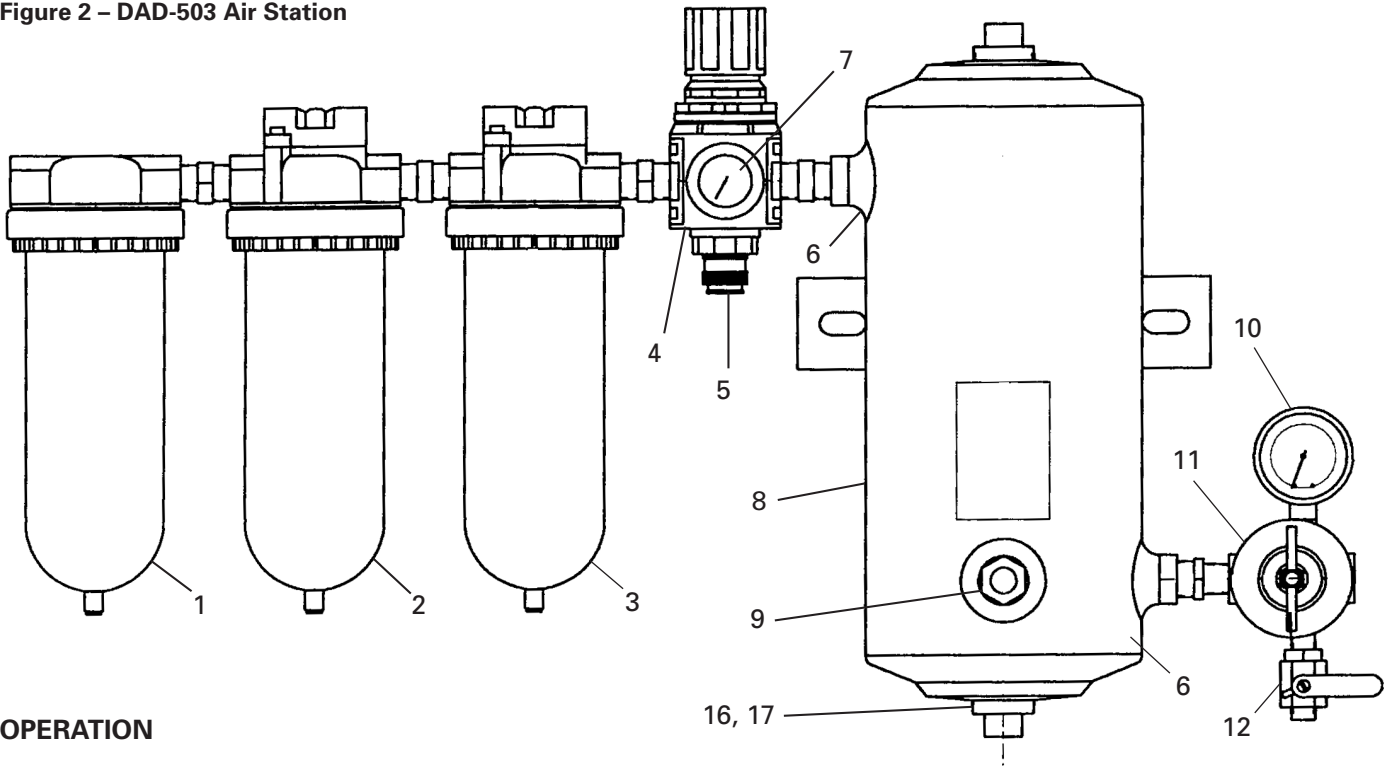

OPERATION

After the system is installed and ready to use;

1. Attach breathable air hose to Q.D. on flow-thru regulator.
2. Attach air hose(s) to outlet valve.
3. Open main shut-off valve upstream of system.
4. Attach breathable air hose to supplied air respirator.
5. Adjust regulator (4) to read 60 PSIG (flowing air to the visor). The pressure should never be allowed to drop below 50 PSI in a flowing condition.
6. Adjust regulator (11) to desired set ting by turning "T" handle in or out.
7. Open ball valve (12) to supply air to spray gun or tool being used. With air flowing, readjust air pressure at regulator if necessary
8. After use, shut off ball valve and bleed off residual air in hose.

MAINTENANCE



Risk of injury. Components under pressure. Relieve air pressure before performing any maintenance.

1. Check system at least once per shift to insure proper drainage. Look for water in the drain tubing.
2. Before performing maintenance on system, close main shut-off valve located upstream. Bleed off residual air in system.

PARTS LIST – DAD-503 Air Station

Ref. No.	Replacement Part No.	Description	Ind. Parts Req.
1	13-0041	Air Filter/Separator	1
2	HAF-505	Coalescing Filter	1
3	HAF-517	Charcoal Filter	1
4	HAR-508	Flow-Thru Regulator	1
5	MPV-424	Breathable Air Quick Release Socket	1
6	DAD-8	Screen (Not Shown)	2
7	GA-316	Gauge	1
8	PT-417	Desiccant Tank (without desiccant, includes Ref. No. 6)	1
9	DAD-400	Humidity Indicator (1 Humidity Indicator Paper Included)	1
10	GA-288	Gauge	1
11	HAR-507	Air Regulator	1
12	VA-542	Ball Valve	1
13	DAD-1	Replacement Desiccant (Not Shown) (1 Humidity Indicator Paper Included)	1
14	DAD-600	Desiccant Tune-Up Kit (Not Shown) (Includes 1 ea: DAD-1 and HAF-6)	1
15	DAD-600-1	Complete Tune-Up Kit (Not Shown) (Includes 1 ea: DAD-1, HAF-21 and HAF-6)	1
16	SSG-8217-K2	O-Ring Kit (2)	1
17	PT-96	Pipe Plug, Special, 1-1/2 NPT	1
18	VA-595	Main Air Supply Shut Off Valve (Not Shown)	1

WATER SEPARATOR FILTER 13-0041 (HAF-502)

Figure 3 – 13-0041 (HAF-502)

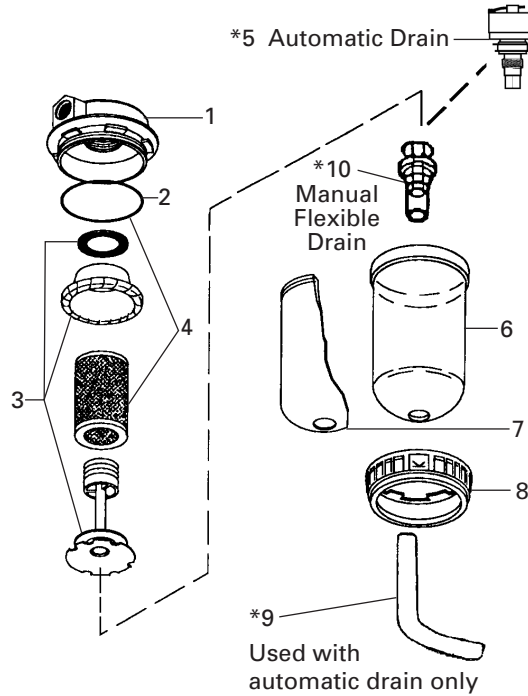

1. Before performing maintenance on unit, close any main shut-off valve located upstream of filter. Bleed off residual air in unit.
2. To open filter, press button located on clamp ring and rotate ring either clock wise or counterclockwise while pulling down on ring. The metal bowl guard and plastic bowl can then be removed from the filter body.
3. Remove the filter element by loosening counterclockwise. Clean or replace the filter element. Frequency of element replacement will depend upon air quality, air usage and condition of the air piping. It is recommended to change the element every six months.
4. Inspect o-ring for damage. Replace if necessary.
5. Inspect plastic bowl for signs of damage such as cracks, crazing or deterioration. Replace if necessary.

PARTS LIST – 13-0041 (HAF-502)

Ref. No.	Replacement Part No.	Description	Ind. Parts Req.
1	—	Cover	1
2	—	O-Ring	1
3	HAF-26	Baffle Kit	1
4	HAF-6	Filter and O-Ring Kit	1
*5	HAF-18	Automatic Drain	1
6	HAF-8	Plastic Bowl	1
7	HAF-19	Metal Bowl Guard	1
8	HAF-409	Clamp Ring	1
*9	—	1/2 x 3/8 Vinyl Tubing (6 ft.)	1
*10	HAF-11	Manual Drain	1

MAINTENANCE – COALESCING FILTER (HAF-505)

Figure 4 – HAF-505 55 CFM Oil Coalescing Filter

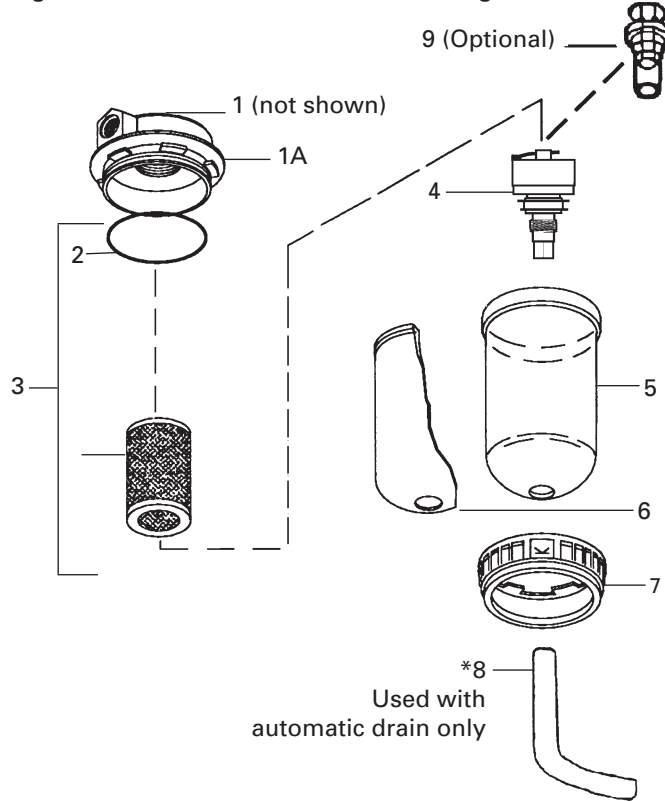

1. Before performing maintenance on unit, close any main shut-off valve located upstream of filter. Bleed off residual air in unit.
2. To open filter, press button located on clamp ring and rotate ring either clockwise or counterclockwise while pulling down on ring. The metal bowl guard and plastic bowl can then be removed from the filter body.
3. Remove the filter element by loosening counterclockwise. Clean or replace the filter element. Frequency of element replacement will depend upon air quality, air usage and condition of the air piping. It is recommended to check the element change indicator daily and replace element when indicator turns red.
4. Inspect o-ring for damage. Replace if necessary.
5. Inspect plastic bowl for signs of damage such as cracks, crazing or deterioration. Replace if necessary.

Note

6. The filter change indicator only operates when air is flowing. It will always be green when there is no air flow.

PARTS LIST HAF-505

Ref No.	Replacement Part No.	Description	Ind. Parts Req.
1	HAF-404	Filter Change Indicator (not shown)	1
1A	---	Cover	1
2	---	O-Ring	1
3	HAF-28	Filter and O-Ring Kit	1
4	HAF-18	Automatic Drain	1
5	HAF-8	Plastic Bowl	1
6	HAF-19	Metal Bowl Guard	1
7	HAF-409	Clamp Ring	1
*8	---	1/2 x 3/8 Vinyl Tubing 6'	1
9	HAF-11	Manual Drain (available separately)	1

MAINTENANCE – CHARCOAL FILTER (HAF-517)

Figure 5 – HAF-517

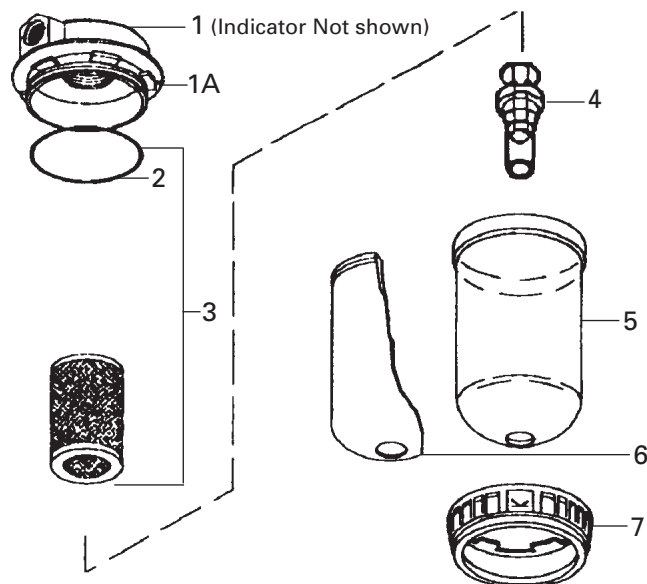

1. Before performing maintenance on unit, close any main shut-off valve located upstream of filter. Bleed off residual air in unit.
2. To open filter, press button located on clamp ring and rotate ring either clockwise or counterclockwise while pulling down on ring. The metal bowl guard and plastic bowl can then be removed from the filter body.
3. Remove the filter element by loosening counterclockwise. Clean or replace the filter element. Replace the charcoal element when it no longer removes oil vapor odors or when the red indicator is visible.
4. Inspect o-ring for damage. Replace if necessary.
5. Inspect plastic bowl for signs of damage such as cracks, crazing or deterioration. Replace if necessary.

PARTS LIST – HAF-517

Ref. No.	Replacement Part No.	Description	Ind. Parts Req.
1	HAF-404	Filter Change Ind. (Not shown)	1
1A	—	Body	1
2	—	O-Ring	1
3	HAF-36	Filter and O-Ring Kit	1
4	HAF-11	Manual Drain	1
5	HAF-8	Plastic Bowl	1
6	HAF-19	Metal Bowl Guard	1
7	HAF-409	Clamp Ring	1

MAINTENANCE – AIR PRESSURE & FLOW-THRU REGULATORS

MAINTENANCE – AIR PRESSURE REGULATOR HAR-507

1. Occasionally remove bottom plug (7) and clean valve seat (11) and body. Clean parts with denatured alcohol, wipe off seat and blow out body with compressed air.
2. To disassemble regulator, remove screws, bonnet, spring and spring button. Diaphragm assembly can now be removed.
3. Check all o-rings for signs of damage. Replace if necessary.
4. Reassemble parts. Insert stem of valve through hole in regulator body. Install spring and o-rings. Screw bottom plug into body.

Note

Erratic operation or loss of regulation is usually due to dirt in the valve area and cleaning is necessary. If cleaning does not correct the problem, replace the items included in Repair Kit KK-4977. If unit leaks air at **A**, install Repair Kit KK-4977.

Figure 6 – HAR-507

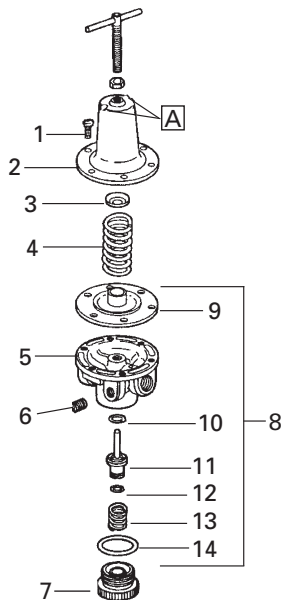

PARTS LIST - Model HAR-507 Regulator Assembly

Ref No.	Replacement Part No.	Description	Ind. Parts Req.
1	---	#10-32 x 9/16 Fillister Head Screw	6
2	HAR-14	Cover	1
3	---	Spring Button	1
4	---	Diaphragm Spring	1
5	---	Body	1
6	---	Pipe Plug 1/4" NPT(M)	1
7	---	Bottom Plug	1
8	KK-4977	Repair Kit (includes Items 9 thru 14)	1
9	---	Diaphragm Assembly	1
10	---	O-Ring	1
11	---	Valve	1
12	---	O-Ring	1
13	---	Spring	1
14	---	O-Ring	1

MAINTENANCE – FLOW-THRU REGULATOR



Do not submerge regulator or components in solvent or use solvent to clean regulator parts. Damage may occur to regulator and components. Use a cloth dampened in warm, soapy water to clean exterior of regulator.

Note

This unit may be serviced without removing the unit from the compressed air line.

1. Frequency of servicing depends largely on the condition of the compressed air system and the degree of contamination in the system.
2. Before attempting to service this product in-line, depressurize both the upstream and downstream sides of regulator.
3. Remove the bottom plug, valve spring and valve assembly. Inspect all seals and components for damage and replace as required. Clean seals and components with mild detergent and water. Use a clean, dry cloth to wipe any contamination from valve seat inside the body. Lubricate the valve

stem and lower valve o-ring seal with a light coat of MAGNALUBE-G or similar lubricant. Reassemble. Bottom plug torque should not exceed 25 in./lbs. (2.8 N-m).

4. To replace main spring or diaphragm, turn adjusting knob counterclockwise to remove all spring force, then remove bonnet. Remove the adjusting screw assembly, main spring, slip ring and diaphragm assembly. Inspect the diaphragm and the relief seat for damage and contamination. Replace diaphragm assembly if necessary. Clean the relief seat with a soft dry cloth. Reassemble in reverse order making sure the slip ring is properly positioned on top of the diaphragm. Bonnet torque should not exceed 120 in./lbs. (13.6 N-m).
5. Before returning unit to service, ensure that all seals have been properly reinstalled or replaced and components requiring torque values have been properly set.
6. If regulated pressure begins to creep (an uncontrolled rise in regulated pressure), it will most likely be caused by contamination on the valve seat.
7. If the unit leaks from the vent holes in the bonnet, it may be caused by contamination, deterioration or damage to the valve seat or diaphragm relief seat. Replace any damaged or worn components.

Figure 7 – HAR-508 Regulator

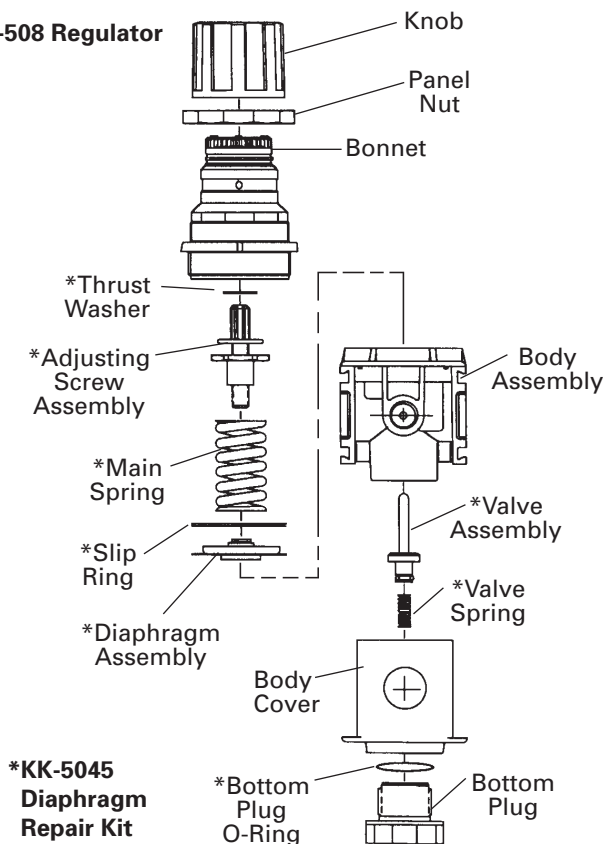

MAINTENANCE – HAF-18 AUTOMATIC DRAIN

Note

The automatic drain includes a float. If water gets into the float, the automatic drain may not function properly. Under normal conditions, water will not enter the float. However, water can get in the float if the filter bowl is washed with the drain installed or if air line contamination causes the drain mechanism to stick.

You can confirm the automatic drain is not operating if the water level in the plastic bowl is higher than the top of the automatic drain.

To remove water from the float, follow these instructions. Be careful not to lose or damage any internal parts of the automatic drain (replacement parts are not available - complete drain replacement will be necessary).

1. Remove automatic drain from plastic bowl by loosening plastic retaining nut. Keep retaining nut and o-ring for reassembly later.
2. Using a knife edge, carefully pry apart the float cover and bottom piece (See Figure 8).

Figure 8

Pry apart with knife edge.

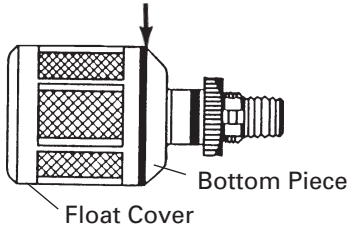
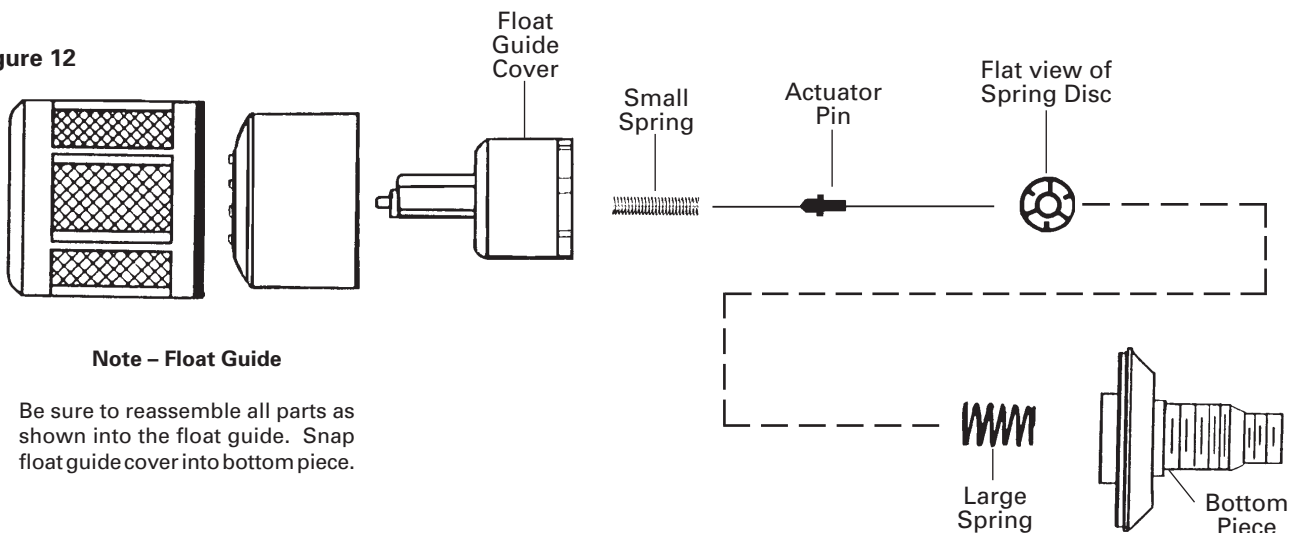

Figure 12



Note – Float Guide

Be sure to reassemble all parts as shown into the float guide. Snap float guide cover into bottom piece.

3. Slide flat off flat guide (See Figure (9)).

Figure 9

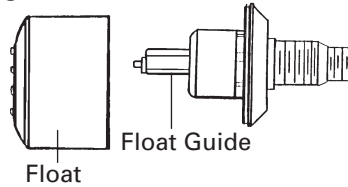

4. Using a knife edge, carefully pry off flat cap (See Figure 10).

Figure 10

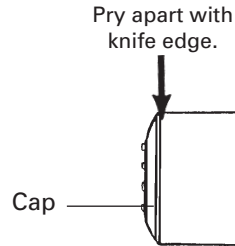

5. Clean inside of flat. Remove all traces of water or dirt.
6. Insure rubber seal is in place in the center of the flat stem (See Figure 11). If the seal comes out, press it back in place in the recess of the stem.

Figure 11

(Inside view of float)

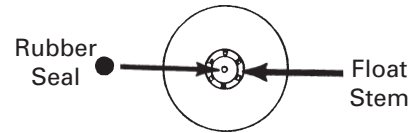

7. Replace the float cap (again, be certain the rubber seal, Figure 11, is in place).
8. Slide float over float guide.
9. Snap float cover onto bottom piece.
10. Install automatic drain into bowl. Be sure o-ring is in place (between the drain and bowl). Tighten the plastic retaining nut firmly by hand.
11. Monitor the automatic drain for proper operation. If it fails to operate properly, replace with a new unit.

Note

If the Float Guide inadvertently came apart, refer to Figure 12 and instructions.

MAINTENANCE – DESICCANT DAD-1

1. Replace the desiccant when the humidity indicator changes to a pink color. Remove the pipe plug at the bottom of the tank. Allow the material to drain into a two (2) gallon or larger container.
2. Once all the material has been removed, replace the pipe plug (see "Note" following) and tighten securely (air tight).

Note

Use PTFE tape on pipe plug threads and all threaded fittings to facilitate removal in the future. Do not use loctite or any material that may bond and make removal difficult.

3. Replace the DAD-3 humidity indicator paper (supplied with DAD-1 Desiccant) by removing the DAD-400 humidity indicator. Pry out the old paper and push in the new paper (printed side facing away from the glass).
4. Remove the pipe plug on top of the unit.
5. Using a funnel (supplied with desiccant), fill the unit using DeVilbiss Desiccant Material Part No. DAD-1 (19-0831) until full.
6. Replace the pipe plug (see "Note" above) and tighten until air tight.
7. The humidity indicator will return to a blue color within five minutes.
8. The desiccant material should be disposed of properly.
9. Refer to the appropriate service bulletin for checking the filters and components.

Note

A desiccant Tune-Up Kit Part No. DAD-600, is available. Contains the following parts to completely recondition a desiccant air station:

Part No.	Description	Qty. Supplied
DAD-1	Desiccant	1
---	Humidity Indicator	1
HAF-6	#1 Filter Element and O-Ring	1

DAD-8 Replacement Instructions for filter between the flow-thru regulator and the desiccant tank air inlet:

Replacing the air filter is not normally needed. It is required only when the filter has been damaged or plugged because the unit was not properly maintained.

10. Be sure air supply to unit is shut off and bleed off all air pressure from the DAD unit.
11. Make sure the desiccant material is drained from unit per above instructions.
12. Disconnect the unit at the union. Remove the filter bowls and filter elements from both the first and second stage filters of the unit.
13. Use an open end 7/8" wrench and remove the hex nipple between the DAD tank and the flow-thru regulator. The nipple should unscrew out of the tank.
14. Using a needle nose pliers, remove the wire screen in the tank fitting.

Note

If the retainer is plastic, use a 1/4" square thread extractor or 1/4" square bar stock to unscrew the retainer out of the tank.

15. Use a #4 Phillips screwdriver and reverse the above procedures to install a new DAD-8 filter. Install about halfway into the tank fitting.
16. Reverse procedure to reassemble. Refill with desiccant.

DAD-8 Replacement Instructions for the filter between the air regulator and the desiccant tank:

17. Be sure air supply to unit is off and bleed all air from the DAD unit.
18. Be sure all desiccant material is drained from the unit. Remove the air regulator (11) from tank by placing a 7/8" wrench on the tank bushing & 1-1/8" wrench on the regulator.
19. Remove the brass bushing from the tank using a 7/8" wrench. The bushing may have a stainless steel screen attached. If so, cut the screen off the bushing with a knife. It will be replaced by the DAD-8 filter. If there is no S/S screen attached, follow the steps below.

Note

If the filter is plastic, use a 1/4" square thread extractor or 1/4" square bar stock to unscrew the filter from the tank.

20. Use a #4 Phillips screwdriver and reverse the above procedures to install a new DAD-8. Install about halfway into the tank fitting.

Note

The air regulator can be installed back on the tank or additional piping can be installed to pipe the air to a different location. Remember that the volume of air flow can be affected by the pipe and distance to the new location. All fittings are regular pipe fittings.

21. Reverse procedure to reassemble. Refill with desiccant.
22. Before placing unit back into service, make sure plastic bowls and metal bowl guards are properly installed and securely locked in place.
23. Confirm automatic drain operates properly after unit is in operation. Replace if necessary.

Refer to SB-6 149 for further instructions.

ACCESSORIES

HAF-407
Mounting Bracket Assembly Kit

DAD-503 (130089) AIR STATION WITH DESICCANT – PIPING

CLEANAIR™ AIR PIPING RECOMMENDATIONS

The plumbing of your shop air lines is very important. Correct installation is necessary for the proper performance of your equipment - for an uncontaminated air supply and for sufficient pressure to your breathing apparatus and spray gun.

Correct air line piping is so important that this one factor alone can reduce contaminants in your air supply up to 75%. Reducing contaminants to the filter also reduces the frequency of filter replacement, maintenance, and of course reduces the risk of contaminants to the painter and paint supply.

Even the size of the pipe is critical. Using pipe that is too small in diameter can cause a pressure drop.

Example: If an air compressor delivers 100 psi through a 100' pipe 1/2" in diameter, there's greater pressure drop than if a 3/4" diameter pipe were used. The chart on the back page provides recommended piping sizes.

AIR LINE PIPING GUIDE

- ① After leaving the air compressor, the air line should go straight up as high as possible. This helps prevent any water from leaving the compressor and travelling through the pipe.
- ② Horizontal pipes should slope back towards the compressor at least 4" per 50'. As warm air leaves the compressor, it cools and thereby water vapor condenses as it travels through the pipe. This water, a problem in itself, also can cause scaling and rust inside the piping. The backward sloping of the pipe helps drain these contaminants back toward the compressor drain which should be drained daily.
- ③ A take off should come from the top of the main air supply line at each air drop. This reduces the risk of water and other contaminants from traveling down the drop into the water separator.

- ④ Pipe diameter must be of sufficient size for the volume of air being passed as well as the length of pipe used. This will minimize pressure drop. See chart.
- ⑤ First air drop should be at least 25' from the compressor, although 50' is optimum. This allows the compressed air to cool so any condensation can occur before it gets to the air filter.
- ⑥ Shut-off valves are installed before the point of use filter. This allows air to be shut off for filter maintenance.
- ⑦ Point-of-use filter - Strongly recommended for eliminating any remaining contaminants. The DeVilbiss CleanAir type air control units are most effective in providing a truly contaminant-free air supply.
- ⑧ Drain valve - The daily draining of the system at each outlet disposes of the contaminants that build up in the air supply.
- ⑨ Drain the compressor trap daily if equipped with a manual drain.

Proper maintenance of the air compressor can reduce airborne contaminants such as particles and oils, and reduce heat and operating cost. Check air filters, oil level and perform regular maintenance per operators manuals.

MINIMUM PIPE SIZE RECOMMENDATIONS CHART

Compressor Size	Compressor Capacity	Main Air Line	Min. Pipe Diameter
1-1/2 and 2 HP	6 to 9 CFM	Over 50 ft.	3/4"
3 and 5 HP	12 to 20 CFM	Up to 200 ft. Over 200 ft.	3/4" 1"
5 to 10 HP	20 to 40 CFM	Up to 100 ft. 100 to 200 ft. Over 200 ft.	3/4" 1" 1-1/4"
10 to 15 HP	40 to 60 CFM	Up to 100 ft. 100 to 200 ft. Over 200 ft.	1" 1-1/4" 1-1/2"

Figure 13 – CleanAir™ Piping

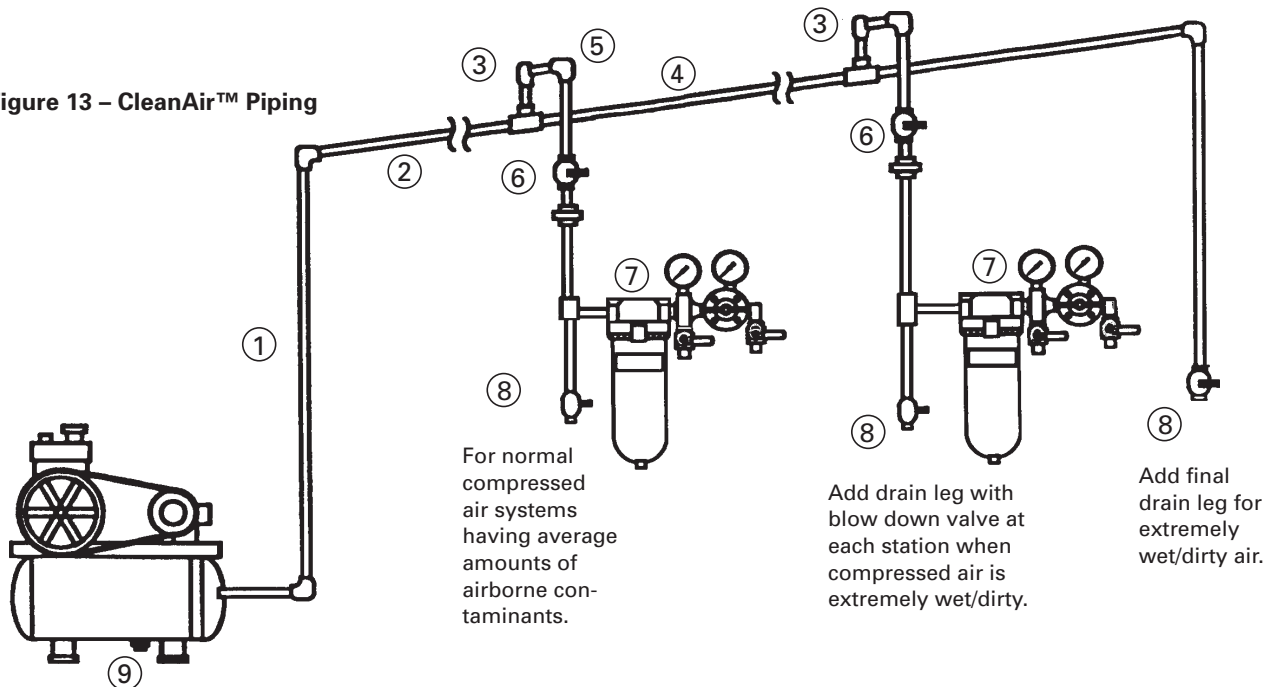

WARRANTY POLICY

This product is covered by Carlisle Fluid Technologies' materials and workmanship limited warranty. The use of any parts or accessories, from a source other than Carlisle Fluid Technologies, will void all warranties. Failure to reasonably follow any maintenance guidance provided may invalidate any warranty.

For specific warranty information please contact Carlisle Fluid Technologies.

Carlisle Fluid Technologies is a global leader in innovative finishing technologies. Carlisle Fluid Technologies reserves the right to modify equipment specifications without prior notice.

DeVilbiss®, Ransburg®, ms®, BGK®, and Binks®
are registered trademarks of Carlisle Fluid Technologies, Inc.

©2019 Carlisle Fluid Technologies, Inc.
All rights reserved.

For technical assistance or to locate an authorized distributor,
contact one of our international sales and customer support locations.

Region	Industrial / Automotive	Automotive Refinishing
Americas	Tel: 1-800-992-4657 Fax: 1-888-246-5732	Tel: 1-800-445-3988 Fax: 1-800-445-6643
Europe, Africa, Middle East, India	Tel: +44 (0)1202 571 111 Fax: +44 (0)1202 573 488	
China	Tel: +8621-3373 0108 Fax: +8621-3373 0308	
Japan	Tel: +81 45 785 6421 Fax: +81 45 785 6517	
Australia	Tel: +61 (0) 2 8525 7555 Fax: +61 (0) 2 8525 7575	

For the latest information about our products, visit www.carlisleleft.com