

# Mini Spray Guns

## Details & Touch-Ups – Gravity



### MGF HVLP Mini Gravity Feed System

The MGF HVLP Mini Gravity Feed system is ideal for all types of touch-up and detail work and sprays all automotive coatings. It is designed for left or right hand use and features an infinitely variable (round to flat) fan control. Includes U07505 (4 oz) aluminum gravity feed cup.

Size	Gun PN	Aircap	Applications
1.4 mm	7040	34806	All automotive colors & clears

- Air Inlet Size: 1/4 in npsm (m)
- Air Consumption: 2.9 CFM
- Max. Inlet Pressure: 40 psi (2.7 bar)
- Aircap Pressure: 10 psi (0.6 bar)
- Weight: 9 oz (0.25 kg)
- Repair Kit: PN 34835
- Instruction Manual: PN 309989
- Reference p. 46

# Mini Spray Guns

## Details & Touch-Ups – Pressure



### MPF HVLP Mini Pressure Feed System

The MPF HVLP Mini Pressure Feed system is excellent for high speed production. It is designed for left or right hand use and features an infinitely variable (round to flat) fan control.

Size	Gun PN	Aircap	Applications
1.1 mm	7045	34808	All automotive colors & clears

- Air Inlet Size: 1/4 in npsm (m)
- Air Consumption: 3.5 CFM
- Max. Inlet Pressure: 40 psi (2.7 bar)
- Aircap Pressure: 10 psi (0.6 bar)
- Repair Kit PN: 34835
- Instruction Manual: PN 309990
- Reference p. 47

### D-5-55 Detail Spray Gun



With atomization equal to a production gun, our D-5-55 Detail Spray Gun is easy to service and easy to use. This gun is ideal for painting small areas. The trigger is designed for right or left hand use. Excellent for all types of paint material.

Size	Gun PN	Aircap	Applications
1.4 mm	7030	29006	All automotive colors & clears

- Air Inlet Size: 1/4 in npsm (R 1/4-19)
- Air Consumption: 4.1 CFM
- Order with Model D-500 cup assembly
- Gun Weight: 8 oz (0.22 kg)
- Repair Kit PN: 29086
- Instruction Manual: PN 309991
- Reference p. 48



- Cup Assembly (6 oz): PN U07510, Model D-500
- Extra Cup with Cover: PN U07530, Model D-500-72

# REFERENCE

## SPRAY GUN REFERENCE GUIDE

	D-5-55	FINEX FX1000	FINEX FX2000	FINEX FX3000	MGF HVLP	MPF HVLP
--	--------	--------------	--------------	--------------	----------	----------

Primers & Sealers						
Nozzle Size mm	1.4	1.4	1.4	1.5	1.4	1.1
Gun PN	7030 (1.4 mm)	289222 (1.4 mm)	288885 (1.4 mm)	288881 (1.5 mm)	7040 (1.4 mm)	7045 (1.1 mm)
Nozzle PN	29021 (1.4 mm)	289290 (1.4 mm)	289293 (1.4 mm)	289299 (1.5 mm)	29021 (1.4 mm)	34811 (1.1 mm)
Aircap PN	29006	Kit	Kit	Kit	34806	34808

Primer Surface						
Nozzle Size mm		1.4	1.8	1.5-1.8		
Gun PN		289222 (1.4 mm)	288887 (1.8 mm)	288881 (1.5 mm) 288882 (1.8 mm)		
Nozzle PN		289290 (1.4 mm)	289295 (1.8 mm)	289299 (1.5 mm) 289300 (1.8 mm)		
Aircap PN		Kit	Kit	Kit		

Single Stage Urethane and Polyurethanes						
Nozzle Size mm		1.2-1.4	1.4	1.3-1.5		1.1
Gun PN		289221 (1.2 mm) 289222 (1.4 mm)	288885 (1.4 mm)	288879 (1.3 mm) 288880 (1.4 mm) 288881 (1.5 mm)		7045 (1.1 mm)
Nozzle PN		289289 (1.2 mm) 289290 (1.4 mm)	289293 (1.4 mm)	289297 (1.3 mm) 289298 (1.5 mm) 289299 (1.8 mm)		34811 (1.1 mm)
Aircap PN		Kit	Kit	Kit		34808

Base Coat						
Nozzle Size mm	1.4	1.2-1.4	1.4	1.3-1.5	1.4	1.1
Gun PN	7030 (1.4 mm)	289221 (1.2 mm) 289222 (1.4 mm)	288885 (1.4 mm)	288879 (1.3 mm) 288880 (1.4 mm) 288881 (1.5 mm)	7040 (1.4 mm)	7045 (1.1 mm)
Nozzle PN	29021 (1.4 mm)	289289 (1.2 mm) 289290 (1.4 mm)	289293 (1.4 mm)	289297 (1.3 mm) 289298 (1.5 mm) 289299 (1.8 mm)	29021 (1.4 mm)	34811 (1.1 mm)
Aircap PN	29006	Kit	Kit	Kit	34806	34808

Clear Coat						
Nozzle Size mm	1.4	1.2-1.4	1.4	1.3-1.5	1.4	1.1
Gun PN	7030 (1.4 mm)	289221 (1.2 mm) 289222 (1.4 mm)	288885 (1.4 mm)	288879 (1.3 mm) 288880 (1.4 mm) 288881 (1.5 mm)	7040 (1.4 mm)	7045 (1.1 mm)
Nozzle PN	29021 (1.4 mm)	289289 (1.2 mm) 289290 (1.4 mm)	289293 (1.4 mm)	289297 (1.3 mm) 289298 (1.5 mm) 289299 (1.8 mm)	29021 (1.4 mm)	34811 (1.1 mm)
Aircap PN	29006	Kit	Kit	Kit	34806	34808

# REFERENCE

## REPLACEMENT PARTS DRAWINGS INDEX

### D-5-55 Detail Spray Gun Parts / Pièces / Piezas

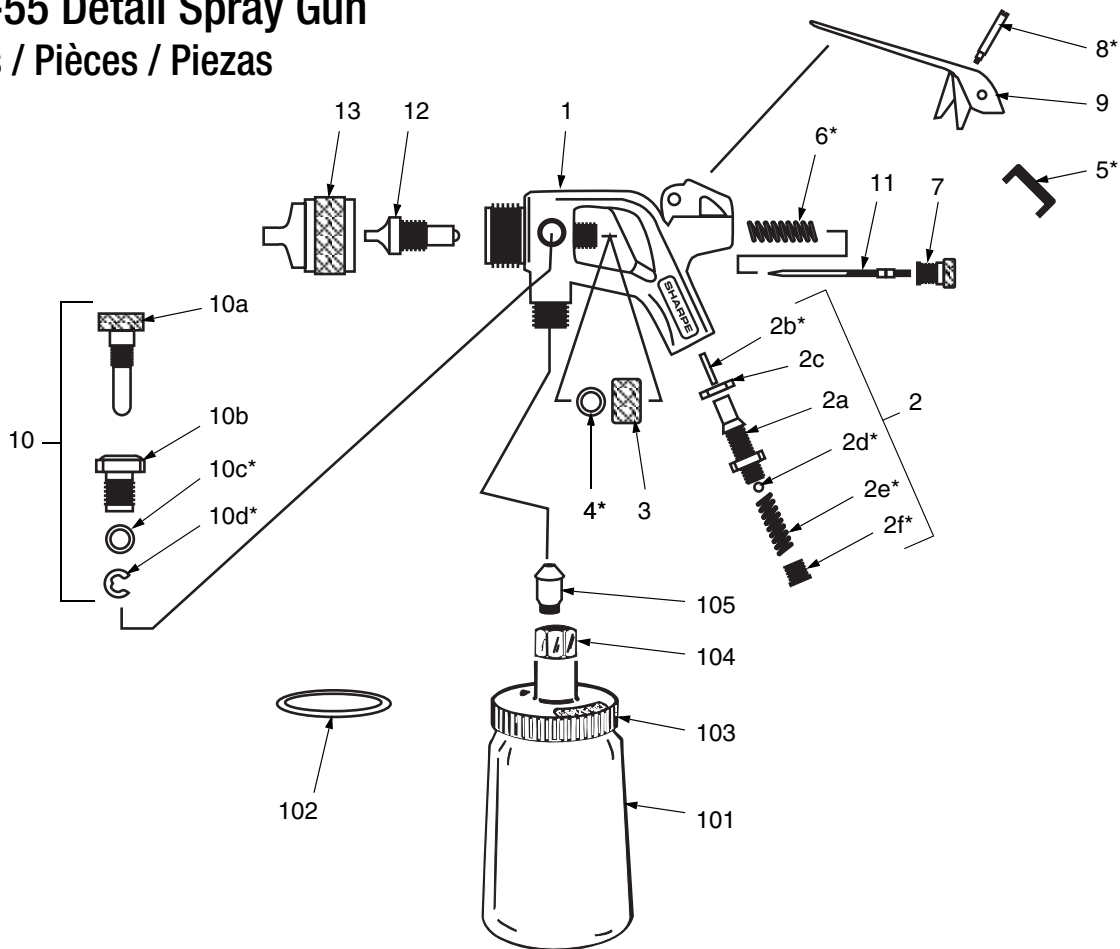

#### Part No. 7030, D-5-55 Detail Spray Gun

Ref. No.	Part No.	Description	Qty.	Ref. No.	Part No.	Description	Qty.
1	29001	Gun Body	1	10a	118749	• Knob	1
2	29054	Air Valve Assembly Includes items 2a-2f	1	10b	118741	• Packing Nut	1
2a	34819	• Housing	1	10c*	29028	• Packing	1
2b*	29049	• Air Valve Stem	1	10d*	29029	• Retaining Ring	1
2c	29053	• Lock Nut	1	11	29041	Fluid Needle	1
2d*	29050	• Ball	1	12	29021	Fluid Nozzle, 0.55	1
2e*	29036	• Needle Spring	1	13	29006	Aircap	1
2f*	29052	• Retainer	1	* Parts included in Repair Kit 29086.			
3	29033	Needle Packing Nut	1	<b>Part No. U07510, D-500 Cup Assembly</b>			
4*	26022	Needle Packing	1	Ref. No.	Part No.	Description	Qty.
5*	29047	Plunger	1	101	U07530	Cup with air-tight cover	1
6*	29036	Needle Spring	1	102	29063	Gasket, pack of 5	1
7	29046	Fluid Control Knob	1	103	29062	Lid with Fluid Tube	1
8*	29056	Trigger Screw	1	104	29057	Coupling Nut	1
9	29055	Trigger	1	105	29058	Nipple Fitting	1
10	29030	Width Control Assembly Includes items 10a-10d	1				