



# MPN Series Poly-Rivet Nut and Thread-Sert

## MPN Series Poly-Rivet Nut

Available in Steel-Zinc Plated or Aluminum

### MPN Series Lowest Profile Poly-Rivet Nut

MPN — Poly-Rivet Nut has very small flange and the lowest profile for near flush installation. Eliminates additional operations of countersinking or dimpling of the parent material. May install with all pneumatic and manual Rivet Nut tools.

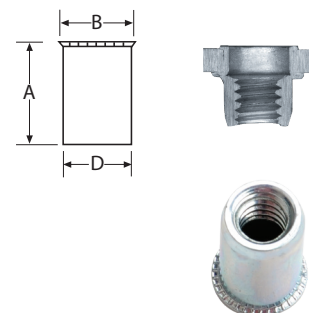

THREAD SIZE	GRIP RANGE Min - Max	STEEL *BULK PART #	ALUMINUM *BULK PART #	A	B	C	D	HOLE SIZE MIN - MAX	DRILL SIZE
				BODY LENGTH @.015	HEAD DIA @.015	HEAD HEIGHT @.005	BODY DIA +0 -005		
				@0.38 MM	@ 0.38 MM	@.0127 MM	TO -0.127 MM		
6-32	.020-.080	M57415	M57510	.410	.287	.017	.249	250-254	1/4
8-32	.020-.080	M57425	M57520	.410	.287	.017	.249	250-254	1/4
10-24	.020-.130	M57435	M57530	.465	.320	.020	.280	281-285	9/32
10-32	.020-.130	M57445	M57540	.465	.320	.020	.280	281-285	9/32
1/4-20	.030-.165	M57455	M57550	.591	.415	.020	.374	375-379	3/8
5/16-18	.030-.165	M57475	M57575	.720	.540	.024	.499	500-504	1/2
3/8-16	.030-.165	M57485	M57585	.720	.540	.024	.499	500-504	1/2
4 MM	.50-2.03	M57407	N/A	10.41	7.29	0.43	6.32	6.35-6.45	6.35
5 MM	.50-3.30	M57409	N/A	11.81	8.13	.61	7.11	7.14-7.23	7.14
6 MM	.76-4.19	M57411	N/A	15.01	10.54	.61	9.50	9.52-9.62	9.52
8 MM	.76-4.19	M57413	N/A	18.29	13.72	.61	12.67	12.7-12.8	12.7
10MM**	.76-4.19	M57414	N/A	18.29	13.72	.61	12.67	12.7-12.8	12.7

\* ALSO AVAILABLE IN SMALL PACKAGED QUANTITIES. \*\* LIMITED AVAILABILITY, MINIMUMS MAY APPLY. INCH SIZES ARE CLASS 2B THREAD. METRIC SIZES ARE CLASS 6H THREAD.

## MTS Series Thread-Sert®

Available in Steel-Zinc Plated or Aluminum

MTS — Thread-Sert fasteners have a small flange and 360 degree swaging action as the Rivet Nut expands inside the hole. Provides high resistance to torque-out with minimal backside protrusion. Can be installed in blind hole with unlimited maximum grip range. May install with all pneumatic and manual Rivet Nut tools.

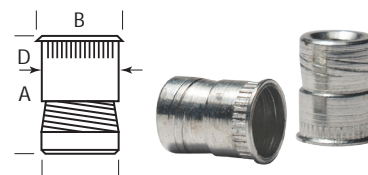

THREAD SIZE	STEEL *BULK PART #	ALUMINUM *BULK PART #	A**	B	D**	MATERIAL THICKNESS .0937-.1562		MATERIAL THICKNESS .1562-INFINITY	
			BODY LENGTH @.005"	HEAD DIA @.005"	BODY DIA @.002"	HOLE SIZE	DRILL SIZE	HOLE SIZE	DRILL SIZE
6-32	M57810	M57910	.375	.250	.215	.221	#2	.234	A(234)
8-32	M57820	M57920	.375	.282	.246	.250	1/4	.261	G(261)
10-24	M57830	M57930	.375	.314	.277	.281	9/32	.290	L(290)
10-32	M57840	M57940	.375	.314	.277	.281	9/32	.290	L(290)
1/4-20	M57850	M57950	.510	.408	.372	.391	3/8	.376	25/64
5/16-18	M57871	M57971	.615	.537	.496	.500	1/2	.516	33/64
3/8-16	M57881	M57981	.740	.600	.559	.562	9/16	.578	37/64

\* ALSO AVAILABLE IN SMALL PACKAGED QUANTITIES. \*\* A AND D DIMENSIONS ARE PRIOR TO SETTING. INCH SIZES ARE CLASS 2B THREAD.



## Rivet Nut Tools and Kits

### Rivet Nut Kit / M39301

Model M39301 Rivet Nut Kit contains the M39300 Rivet Nut tool in a molded plastic case; mandrels and nosepieces for 6-32, 8-32, 10-24 and 1/4-20, instructions and wrench. The kit also includes 103 assorted Klik Rivet Nuts and Klik Poly-Nuts: 25 each M57210, M57425, M57130; 20 each M57250; 8 each M57445. Weight: 2.75 lbs.

### Poly-Nut Kit / M39302

Model M39302 Poly-Nut Kit contains the M39300 Rivet Nut tool in a molded plastic case with 8-32, 10-32 and 1/4-20 mandrels and nosepieces, wrench and instructions. The kit contains 52 assorted Klik Poly-Nuts: 12 each M57425, M57435, M57445; 16 each M57455. Weight: 3 lbs.

### Metric Poly-Nut Kit / M39303

Model M39303 Metric Poly-Nut Kit contains the M39300 Rivet Nut tool in a molded plastic case with 4mm, 5mm, 6mm and 8mm mandrels and nosepieces, wrench and instructions. The kit contains 75 assorted Klik Poly-Nuts: 25 each M57407, M57409; 15 each M57411; 10 each M57413. Weight: 3.25 lbs.

### Ribbed Rivet Nut Kit / M39315

Model M39315 Ribbed Rivet Nut kit contains the M39300 Rivet Nut tool in a molded plastic case; mandrels, nosepieces, wrench and instructions for setting 8-32, 10-24, 10-32 and 1/4-20 Rivet Nuts. The kit also includes 50 assorted Ribbed style Rivet Nuts: 12 each M57320, M57330, M57340; 8 each M57350; 6 each M57354. Weight: 2.75 lbs.

### Quad Leg Nut Installation Tool (MJN-2 / M39043)

Marson's MJN-2 hand-held Quad Leg Nut Installation tool is designed to effortlessly set quad leg nuts and Jack Nuts® in sizes ranging from #6-32 to 1/4-20 and M4 to M6. It works by threading the bolt to the quad leg nut, then dropping the component in the slot of the tool, inserting it into the pre-drilled hole and squeezing until set. Tightening the exposed bolt completes the installation.

Jack Nut® is a registered trademark of Stanley Engineered Fastening.



### Metric Ribbed Rivet Nut Kit / M39316

Model M39316 Ribbed Rivet Nut kit contains the M39300 Rivet Nut tool in a molded plastic case with 4mm, 5mm and 6mm mandrels and nosepieces, wrench and instructions. The kit also includes 50 assorted Ribbed style Rivet Nuts: 12 each M57360, M57385, M57384; 8 each M57386; 6 each M57387. Weight: 2.75 lbs.

### Steel Klik Thread-sert Kit / M39314

Model M39314 Thread-sert Kit contains the M39300 Rivet Nut tool in a plastic case with 6-32, 8-32, 10-24, 10-32, 1/4-20, 5/16-18 and 3/8-16 mandrels and nosepieces, wrench and instructions. The kit contains 62 assorted Steel Klik Thread-serfs: 10 each M57810, M57820, M57830, M57840, M57850; 6 each M57871, M57881. Weight: 3.25 lbs.

### Aluminum Klik Thread-sert Kit / M39313

Model M39313 Thread-sert Kit contains the M39300 Rivet Nut tool in a molded plastic case with 6-32, 8-32, 10-24, 10-32, 1/4-20, 5/16-18 and 3/8-16 mandrels and nosepieces, wrench and instructions. The kit contains 62 assorted Aluminum Klik Thread-serfs: 10 each M57910, M57920, M57930, M57940, M57950; 6 each M57971, M57981. Weight: 3 lbs.

