

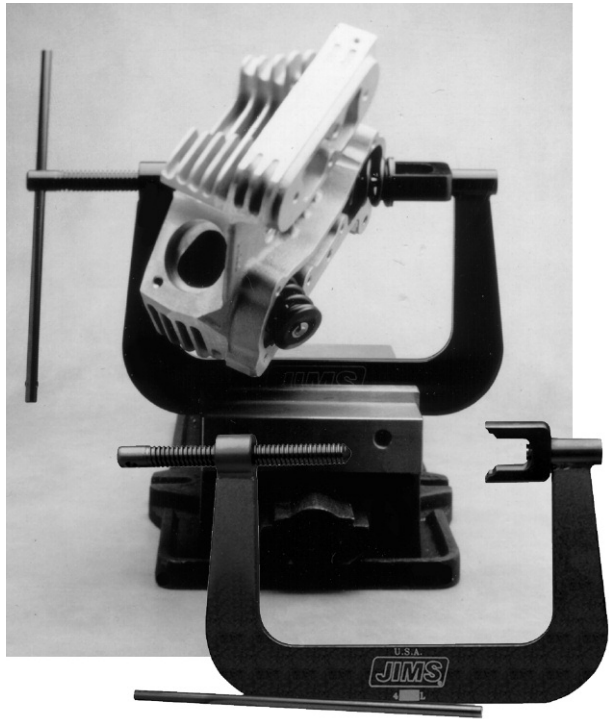

INSTRUCTION SHEET FOR #96600-36B & #988



VALVE SPRING COMPRESSOR TOOL

USE ON ALL BIG TWINS TO 03.
 USE ON ALL K, & XL'S TO 03.
 USE ON ALL BUELLS TO 02.
 USE ON ALL BIG TWIN S.E. MODELS TO PRESENT.
 USE ON ALL V-ROD MODELS TO PRESENT.
 SEE P/N 988 BELOW FOR THE LATEST MODELS.

Necessary for Removing or Installing Valves and Springs.

1. See H.D.® Service Manual for specifications.
2. Apply a small amount of lube to all moving parts.

PART NO. 96600-36B

PARTS AVAILABLE SEPARATELY

No.	Qty.	Description	Part No.
1	1	5/16 HANDLE	96600-36B-4
2	1	5/8 SCREW	96600-36B-3
3	1	MAIN BODY	96600-36B-7
4	1	COLLAR WITH RING	96600-36B-9
5	1	SNAP RING	2145

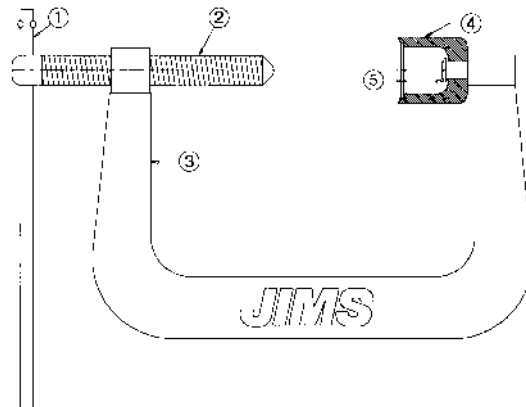

PART NO. 988

CONICAL VALVE SPRING COLLAR

USE ON ALL 05 TO PRESENT BT'S (EXCEPT SE MODELS).
 USE ON ALL 04 TO PRESENT XL'S, 03 TO PRESENT BUELL TWINS.

INSTRUCTIONS

1. Remove item #5 snap ring. Slide off existing collar.
2. Slide on No. 988 and reinstall item #5 snap ring.

**CAUTION: WEAR SAFETY GLASSES. EXCESSIVE FORCE MAY DAMAGE PARTS!
 SEE JIMS® CATALOG FOR HUNDREDS OF TOP QUALITY PROFESSIONAL TOOLS.
 THE LAST TOOLS YOU WILL EVER NEED TO BUY.**

Performance Parts For Harley-Davidson® Motorcycles