

25-Gallon Gas Caddy

Model No. FC-25GC
Owners Manual



151 Snyder Ave.
Barberton, OH 44203
www.johndow.com
customerservice@johndow.com

FC-25GC-MAN

REV 07/17

INSTRUCTIONS PERTAINING TO THE RISK OR INJURY TO PERSONS.

IMPORTANT SAFETY INSTRUCTIONS. SAVE THESE INSTRUCTIONS.



READ THIS MANUAL CAREFULLY BEFORE INSTALLING, OPERATING OR SERVICING THIS EQUIPMENT

It is the responsibility of the employer to place this information in the hands of the operator. Keep for future reference.



DANGER

Indicates an imminently hazardous situation which, if not avoided, will result in death or serious injury.

1. Gasoline and other fuels are extremely flammable. Keep away from heat sparks and open flames as an explosion will result in severe personal injury.
2. Gasoline vapors can explode. Harmful or fatal if swallowed. Avoid breathing fuel vapors.
3. Attach ground wire and bond containers or equipment that are being pumped from and into to neutralize the potential charge between them
4. Ground all containers for extra safety by connecting the containers to a metal pipe or rod that is buried underground.
5. This product is an atmospheric tank. **DO NOT** modify this tank or its components. All components and design features have been tested and approved for use for handling flammable fuels.
6. **DO NOT** use funnels when transferring fuel through the fill tube.
7. Avoid excess agitation, shaking, splashing or high-flow rates as these can increase the risks of static charge build up.
8. **DO NOT** use electronics or mobile communication devices such as mobile phones while dispensing or handling fuel.
9. **DO NOT** smoke near or while using this gas caddy.
10. This product is intended for fuel transfer only and is **NOT** to be used to transport fuel in any vehicle or trailer.



WARNING

Indicates a potentially hazardous situation which, if not avoided, may result in death or serious injury.

1. Obtain Material Safety Data Sheets on fuels being handled. Always wear required proper personal protection equipment and clothing.
2. **DO NOT** tip or operate on incline surfaces.
3. Keep both hands on the handles when maneuvering to maintain control.
4. When using this product precautions should always be followed, including the following:
 - a. Read all instructions before using this product.
 - b. To reduce the risk of injury, close supervision is necessary.
 - c. Keep out of reach of children.
 - d. **DO NOT** put fingers or hands into openings or into the pump.
5. Ensure that all fittings and threaded hose and pipe connections are tightened and leak free.



CAUTION

Indicates a potentially hazardous situation which if not, avoided, may result in minor or moderate personal injury. It may also warn of unsafe practices.

1. Be certain all operators of the equipment have been trained for safe working practices and understand its limitations.
2. Use Caddy for "one type of fuel ONLY" to avoid possible damage to vehicle.
3. Use care when maneuvering to prevent injury or loss of control. Seek assistance to avoid strain or injury when required.
4. Not for prolonged storage of fuel.
5. Monitor flow rate and fill levels to prevent overflows and spills. **DO NOT** overfill containers, drums or tanks.
6. Always empty the pump and hose after use by lifting the hose and turning the handle in the opposite direction of the arrow to empty all remaining liquids back into the caddy.

Product Specifications:

Tank:		Rotary Pump:	
Type:	Steel, portable	Type:	Rotary vane positive displacement, UL listed
Maximum capacity:	25 gallons (95 liters)	Weight:	13 lb (5.9 kg)
		Output per turn:	0.074 gal (0.28L)
		Output rate:	7.4 gpm (28 Lpm) @ 100 rpm

TOOL REQUIRED:

Adjustable Wrench Phillips Screwdriver PTFE Tape (Not Included)

ASSEMBLY:

1. Remove the Gas Caddy tank, pump and accessory kit from shipping carton. Check carefully for concealed damage.
2. Thread the pump (inlet port) to the 3/4" pump stand (top, rear) and tighten. **(See Fig. 1)**
3. The inlet port is marked on the pump with the "IN" arrow. **(See Fig. 2)**
4. Thread the hose assembly into the top of the pump and tighten with a wrench.
5. Assemble the pump handle and attach to the pump. Tighten with wrench.
6. Attach the green ground wire to the metal tab located on the right side of the Gas Caddy handle support bracket. **(See Fig. 3)**
7. Remove shipping tape from the fluid level gauge, attach the plastic dome, seal, and tighten the plastic nut by hand to secure. **(See Fig. 4)** Make certain the indicator mark is positioned to align the float inside the tank. **(See Fig. 5)**
8. If desired, attach identification label. (Unleaded, Gasoline, Diesel, Kerosene or Transmission Fluid) to the front of the Gas Caddy.

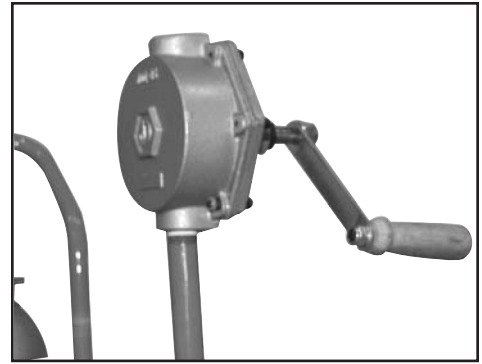

Fig 1

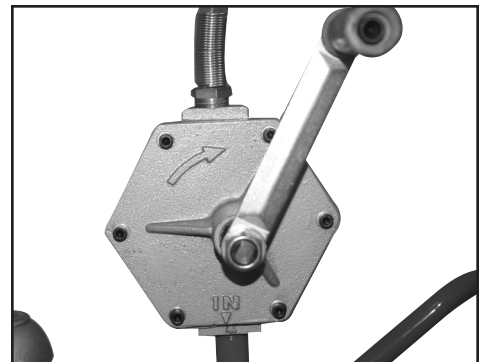

Fig 2



Fig 3



Fig 4

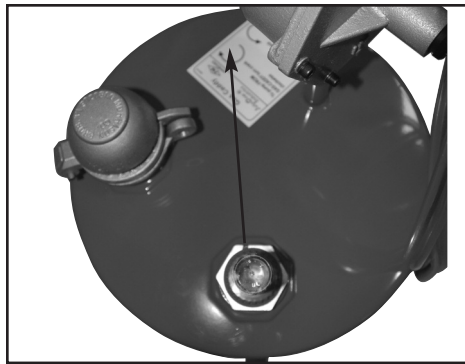

Fig 5

OPERATION:

1. Attach the green ground wire clamp to a known ground on the vehicle being serviced.
2. Place the suction/drain hose in the vehicle.
3. Rotate the pump handle briskly to obtain initial prime.
4. Rotate the handle clockwise (as shown by the arrow on the pump) to draw from the gas caddy, rotate counter-clockwise for suction.
5. The gas caddy may also be filled by removing the fill cap and filling through the fill tube. **DO NOT OVERFILL.** Fuel level must be below the flame arrester screen under the fill tube.

REPLACEMENT PARTS:

Item	Description	Qty	Part No.
1	Tank	1	-
2	Handle	1	-
3	M6 Shoulder Screw	2	-
4	Flat Washer	3	-
5	M6 Nylon Insert Nut	2	-
6	Wheel	2	Included in 25GC-WRK
7	Flat Washer	4	Included in 25GC-WRK
8	M16 Hex Cap Screw	2	Included in 25GC-WRK
9	Axle	2	Included in 25GC-WRK
10	M16 Nylon Insert Nut	2	Included in 25GC-WRK
11	Fuel Gauge Assembly	1	25GC-FG
12	Fill Cap with Vent	1	FIG-379
13	Rotary Hand Pump - UL Listed	1	JDI-35
14	Hose Assembly	1	80-593-NI
15	Ground Wire	1	80-572
16	M6 x 12 Phillips Head Screw	1	-

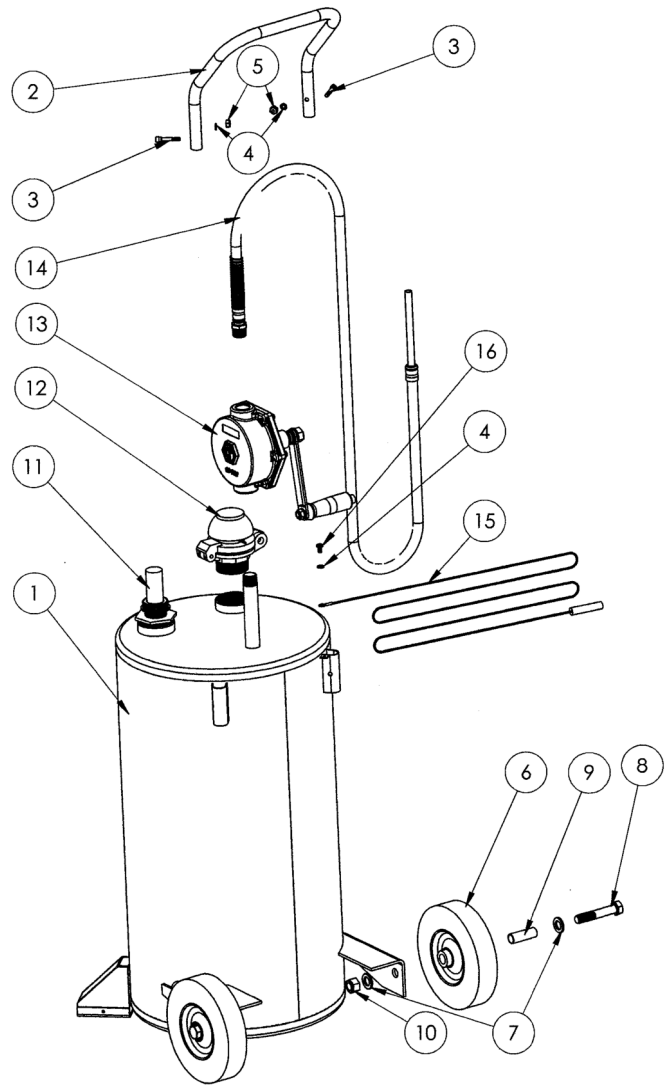

AVAILABLE REPLACEMENT KITS:

Item	Description
25GC-WRK	Wheel Replacement Kit

For Service Assistance
Phone Toll Free 1-800-433-0708
www.johndow.com