



## OWNER'S MANUAL/OPERATING INSTRUCTIONS

### QPK-20 (QUICK PULL KIT)

## WARNINGS & SAFEGUARDS FOR WELDING & CUTTING OPERATIONS

**Important** - Protect yourself and others! Remember that safety depends on you.

The operator, supervisor, and helper must read and understand all warning and safety information provided in these instructions and the power source manual used with this equipment. **Serious injury or death** could result if welding equipment is not properly installed, used, and maintained.

Training and proper supervision are most important for a safe work place. Installation, operation, repair work, and maintenance must be performed by qualified personnel. Retain these instructions for future use. Additional recommended safety and operating information is referenced in each section.

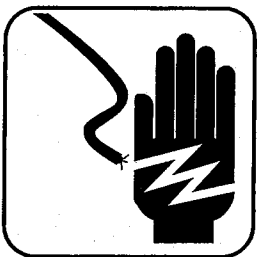

### ELECTRICAL SHOCK CAN CAUSE INJURY OR DEATH

Electrical equipment must be installed and maintained in accordance with the National Electrical Code, NFPA 70, and all local codes. Maintain Electrode Holders, Work Clamp, Welding Cable, and Welding Machines in good, safe operating condition. Replace worn or damaged insulation. Do not try to repair or service equipment while the power is still on. Do not service or repair equipment unless you are trained and qualified to do so. The Electrode and Work (or Ground) circuits are electrically "HOT" when the trigger is pulled.

At no time should you touch the Electrode and Electrical Ground at the same time with bare skin while the trigger is pulled.

Always be sure the work cable makes a good electrical connection with the metal being welded.

Never touch electrically "HOT" parts of electrode holders.

References: See Safety and Operating References A, F, H, and I.

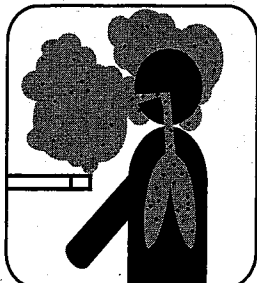

### SMOKE, FUMES, AND GASES CAN BE DANGEROUS TO YOUR HEALTH

Keep smoke, fumes, and gases from your breathing zone and the general area. Smoke, fumes, and gases from the welding process are of various types and strengths, depending on the kind of base metal being welded on. To ensure your safety, do not breath these fumes or gases. Ventilation must be adequate to remove smoke, fumes, and gases during the welding procedure to protect operators and others in the immediate area.

References: See Safety and Operating References A, B, C, H, and I.

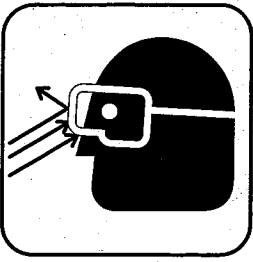

## **MOLTEN MATERIAL, AND SPARKS CAN CAUSE EYE AND SKIN INJURY**

Always wear approved eye, ear and body protection. Remove any and all combustible material from the work area. Never attempt to weld without proper eye protection that conforms to federal guidelines.

Protect other nearby personnel from sparks. Use approved shielding curtains and appropriate goggles. Warn them not to watch the arc or expose themselves to arc rays, sparks, or molten

material.

Always wear protective gloves which will not allow skin to come in contact with heat, or molten material. Wear ear plugs to protect ears from sparks.

References: See Safety and Operating References A, B, H, and I.

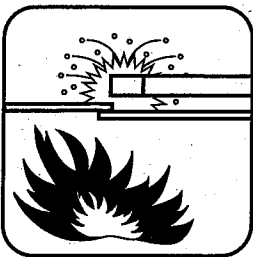

## **SPOT WELDING SPARKS CAN CAUSE FIRES AND EXPLOSIONS**

Remove any and all combustible materials from the work area. If this is not possible, cover them to prevent the welding sparks from starting a fire. Causes of fire and explosion are any combustibles reached by flying sparks or heated materials. Do not wear any gloves or clothing that has oil or a fuel type material on it. Always have a properly working and OSHA recognized Fire Extinguisher near and be sure everyone has proper training in its use.

All hollow spaces, cavities, and containers should be vented prior to welding for they may explode. Make sure proper steps have been taken to ensure that venting procedures will not form flammable or toxic vapors from substances inside containers.

References: See Safety and Operating References A, D, E, F, G, and H.

## **SAFETY AND OPERATING REFERENCES**

- A) ANSI Z49.1, "Safety in Welding and Cutting"
- B) ANSI Z87.1, "Practice for Occupational and Educational Eye and Face Protection"
- C) ANSI Z88.2, "Standard Practice for Respiratory Protection" ANSI: American National Standard Institute, 1430 Broadway, New York, NY 10018
- D) AWS F4.1, "Recommended Safe Practices for Welding and Cutting Containers" AWS: The American Welding Society, P.O. Box 351040, 550 NW Lejeune Rd., Miami, FL 33135
- E) NFPA 51B, "Fire Prevention in Cutting and Welding Processes"
- F) NFPA-70, "National Electrical Code" NFPA: National Fire Protection Association, Batterymarch Park, Quincy, MA 02269
- G) GGA P-1, "Precautions for Safe Handling of Compressed Gases in Cylinders" CGA: Compressed Gas Association, 1235 Jefferson Davis Hwy., Arlington, VA 22202
- H) Code of Federal Regulations (OSHA) 29 CFR 1910 US: U.S. Government Printing Office, Washington, DC 20402
- I) CSA Standard W117.2, "Safety in Welding, Cutting and Allied Processes" CSA: Canadian Standards Association, 178 Rexdale Blvd., Rexdale, Ontario, Canada M9W 1R3

# OPERATING INSTRUCTIONS - QPK-20

## (QUICK PULL KIT)

The **QPK-20** attachment comes complete with 7 ft. power cable assembly, 7 ft. ground cable assembly, A-201 metal shrinking tip, allen wrench, and package of extra star tips (10). The QPK-20 attachment can be used with all Lenco resistant spot welders.

**WARNING:** Operators wearing any type of heart pacemaker should consult a physician before operating or being in area during operation of this equipment.

Follow disarming procedures recommended by automotive manufacturers for electrical and air bag systems.

**HOOKUP:** Bolt the QPK-20 cable lugs on the opposite side of the welder terminals to the existing cable assembly. Make sure both bolts and nuts are tight. Unplug existing trigger switch plug from the receptacle and insert the 2-prong trigger switch plug for the QPK-20. (3000/5000 series welder requires conversion kit [CK-35] or adapter kit [AK-3000].

**CAUTION:** When using the QPK-20, take proper care to ensure the electrodes on the other cable assembly are not contacting one another or contacting any conductive material. (Use enclosed tip covers.)

## QPK-20 OPERATION

### DENT PULLING

1. Turn the power switch to ON position.
2. Set the timer control between 0 and 1/2.
3. Check to ensure the star tip is tight in the electrode head.
4. Remove all paint and rust from contact areas (base metal) on the panel to ensure a good weld of the star tip and ground clamp.
5. Attach the ground clamp directly to the panel being worked on or use optional magnetic base assembly.
6. Using the QPK-20, place the star tip on the panel. Applying moderate pressure, press the trigger switch - you have welded the star tip to the work surface.
7. Applying back pressure to the QPK-20, operate the slide hammer to make the pull.
8. After the pull is made, twist the QPK-20 in a clockwise, counter-clockwise direction to separate the star tip from the work surface.
9. If additional pulls are necessary, repeat using same procedures.
10. The star tip may be rotated to a new point by removing and retightening the compression screw in the electrode head.

### OPTIONAL TIPS

1. A-202 (Slotted Tips) use standard USS 1/4" washer. Set timer control between 1/2 and 1.
2. SPK-102 (Long Stud Welding Tip) to weld SPK-109 (2"x.090 pins) Set timer control to between 1/2 and 1.
3. SPK-103 (Molded Rivet Welding Tip) to weld SPK-110 mold rivets. Set timer control to 1/2.

**Note:** When using above tips, make sure ground is in place and making good contact.

### METAL SHRINKING

1. Remove compression screw and star tip.
2. Insert the A-201 shrink tip in the electrode head with hand pressure.
3. Set the timer control to 5 (maximum).
4. Properly clean shrinking area.
5. Attach the ground clamp directly to the panel being worked on or use optional magnetic base assembly.
6. Using the QPK-20, place the shrink tip on the panel. Applying moderate pressure, press the trigger switch 2 times - this should shrink the metal.
7. Remove the tip by tapping the electrode head to loosen the taper fit.

### HELPFUL HINTS

1. If the star tip is melting, the timer needs to be turned down.
2. If the tips do not operate satisfactorily:
  - a. Paint was not removed from surface.
  - b. Too much pressure was applied.
  - c. Star tip point too blunt - needs to be dressed to a point or rotated to a new point on star tip.
  - d. Timer setting is too low.

Refer to the **LENCOSPOT® MARK II®** Operating Instructions for additional information on panel installation and operation.



# "QUICK-PULL" REPLACEMENT PARTS

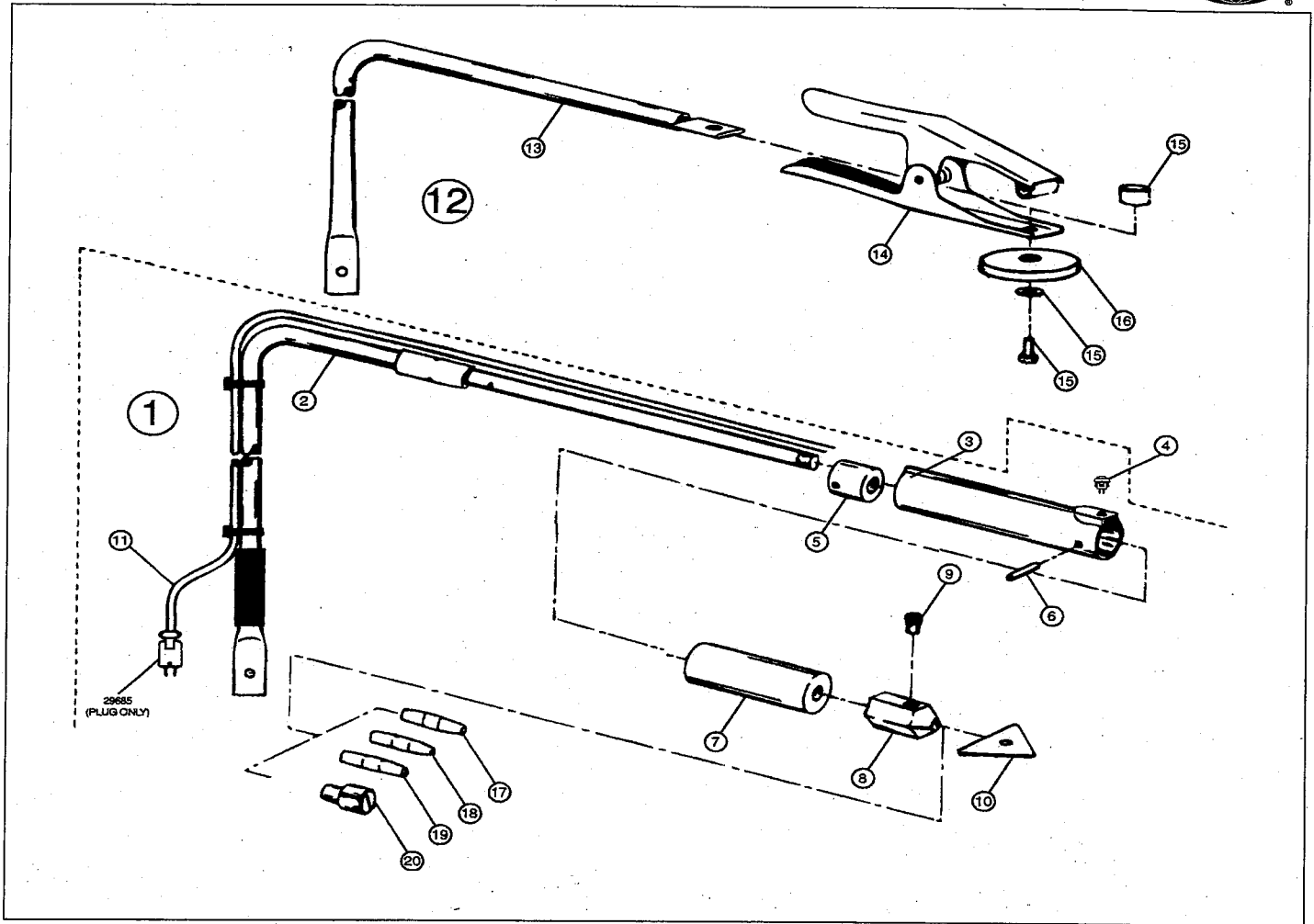

ITEM NO.	PART NO.	ORDERING NO.	DESCRIPTION
	<b>QPK-20</b>	<b>27420</b>	<b>"Quick-Pull" Dent Pulling Attachment</b>
<b>POWER CABLE ASSEMBLY</b>			
1	QP-421	27421	Complete Power Cable Assembly
2	QP-422	27422	Cable Assembly and Electrode Rod w/Lug and Cable Ties (12)
3	QP-449	27449	Handle
4	LAS-170	23170	Switch
5	QP-431	27431	Striker Bushing
6	QP-432	27432	Spring Pin
7	QP-433	27433	Slide Hammer
8	QP-424	27424	Electrode Head Kit (includes head, compression screw, A-201 tip, pkg. 10 star tips, allen wrench)
9	QP-425	27425	Compression Screw
10	QP-451	27451	Star Tip (10 Pieces)
11	QP-443	27443	Switch Cord w/plug and Cable Ties (12)
<b>GROUND CABLE ASSEMBLY</b>			
12	QP-461	27461	Complete Ground Cable Assembly with Magnetic Base
13	QP-462	27462	Cable Assembly w/Lugs
14	QP-463	27463	Ground Clamp
15	QP-464	27464	Ground Tip w/Mounting Bolt
16	QP-465	27465	Magnetic Base Assembly
17	SPK-102	28916	Welding Tip - Long Stud (optional)
18	SPK-103	28917	Welding Tip - Molding Rivets (optional)
19	A-201	21090	Welding Tip - Blunt, Heat Shrinking
20	A-202	21100	Welding Tip - Slotted (optional)

**LENCO AUTOMOTIVE EQUIPMENT**  
**FOR TECHNICAL ASSISTANCE CALL: (800) 747-4743**