

## 43300 PNEUMATIC FAN CLUTCH WRENCH SET

Updated Driving Wrench Assortment in Case.

Quickly removes and installs fan clutch when repairing the water pump or fan clutch. Faster and easier than conventional fan clutch wrenches. No holding wrench is necessary. Set includes 7 driving wrenches that fit Ford, GM, Chrysler & Jeep. Set now includes 7/8", 32mm, 36mm, 40mm thin and new 47mm size to fit Ford 6.0L and 6.4L Powerstroke diesel pickup. 1-7/8" and 2" are still included in the set. 1-1/2", 41mm and 42mm are still available individually. Use with an air hammer.

43300 Pneumatic Fan Clutch Wrench Set. Molded Case. Shipping wt. 9 lbs. 5 oz.

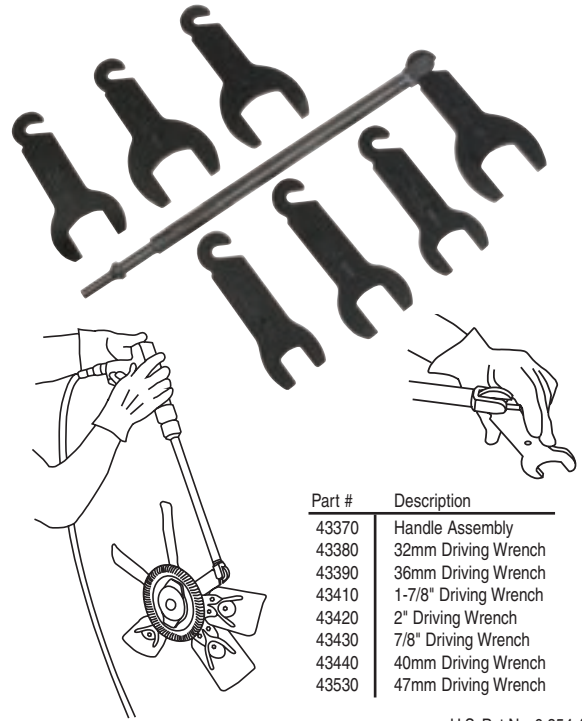

Part #	Description
43370	Handle Assembly
43380	32mm Driving Wrench
43390	36mm Driving Wrench
43410	1-7/8" Driving Wrench
43420	2" Driving Wrench
43430	7/8" Driving Wrench
43440	40mm Driving Wrench
43530	47mm Driving Wrench

U.S. Pat No. 6,354,178

## 44180 FAN CLUTCH SPANNER WRENCH

For GM, Jeep and Dodge Trucks, Vans and SUVs With Pressed on Water Pump Pulleys.

The double-ended spanner wrench fits the holes in pressed-on water pump pulleys. Hold the pulley firm with the spanner wrench. Use the appropriate open end wrench to turn the fan clutch nut (41740 36mm turning wrench works on many applications).

44180 Fan Clutch Spanner Wrench. Skin-packed. Shipping wt. 2 lbs. 5 oz.

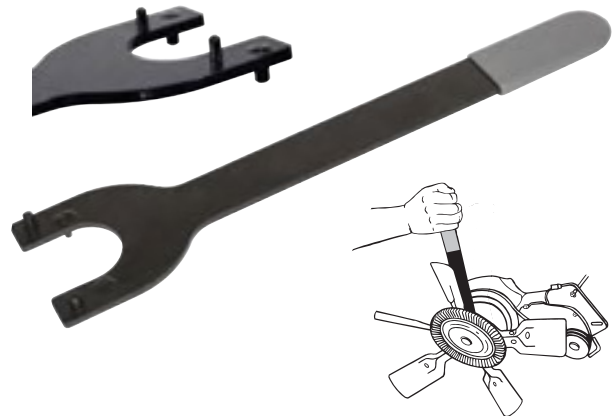

FAN CLUTCH

## 42920 UNIVERSAL FAN CLUTCH WRENCH SET

Removes Fan Clutch on Most Models.

2-piece set removes & installs fan clutches. Includes a universal holding wrench & a universal turning wrench. Holding wrench is adjustable to fit bolts that attach pulley to the water pump. The turning wrench has the 5 common fan clutch nut sizes built into one tool: 7/8" (22mm), 1-7/16" (36mm), 1-9/16" (39mm), 1-7/8" (47mm) and 2" (50mm).

42920 Universal Fan Clutch Wrench Set. Boxed. Shipping wt. 8 lb. 5 oz.

42930 Turning Wrench.

42940 Holding Wrench.

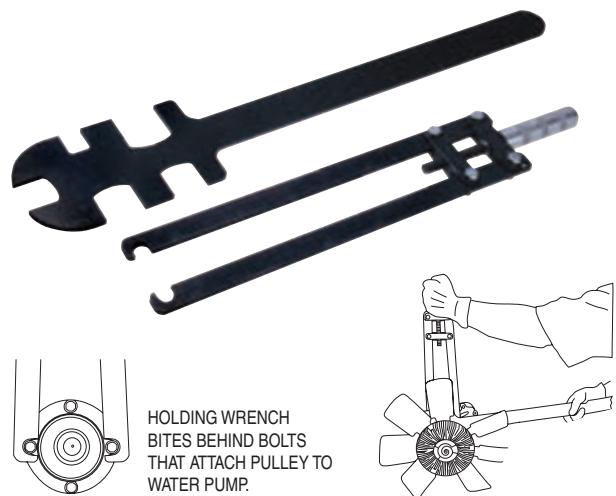

HOLDING WRENCH BITES BEHIND BOLTS THAT ATTACH PULLEY TO WATER PUMP.