

DOOR ALIGNER TOOL

82350

- Align car and truck doors with either bolted or welded hinges in seconds by using leverage
- Quickly and easily mounts in place with no special tools
- Patented feature pulls door against tool to prevent distorting the metal around latches
- Curved handle allows access in restricted areas
- Includes special pin for truck doors
- High quality all steel construction
- Painted safety orange for high visibility

U.S. Patent Nos. 5,331,837 and 7,040,135.

Easily used in 4 steps:

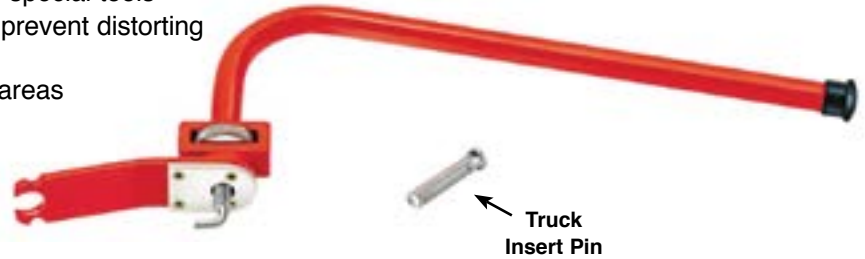

1. Install



2. Tighten

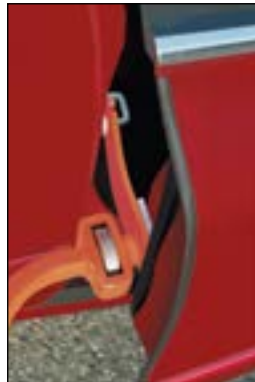

3. Position



4. Adjust



DOOR SPRING TOOL

87675

Use to remove and install the door hinge springs found on late model General Motors cars and light trucks (with larger diameter springs). Makes a hard job easy. Can be used with a 1/2" open end or ratcheting box wrench. Always wear eye and face protection.



CARDED

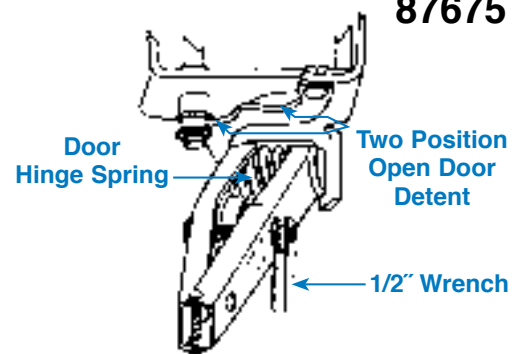

DOOR ALIGNER HINGE SPRINGER

87500

87500 - Repair sprung doors on domestic and foreign made vehicles with box type door hinges in deep or shallow wells. Knurled surface prevents slippage. Use on front and rear door hinges and trunk lids.



CARDED

BUFFING BONNET CLEANING TOOL

87975

87975 - Extends life of all buffing pads and bonnets without taking them off the polisher. Cleans and revitalizes in one operation. Removes glazed surface and fluffs packed wool. Brings pads and bonnets back to like new condition in seconds. Minimizes washing. Wear eye protection.



CARDED