

**1/4 TON-500 LB CLUTCH JACK - HEAVY DUTY**

**MODEL 3700**

- Provides "one-man" operation for removal, installation, and transportation of heavy duty truck clutches
- Includes two splined alignment shafts (2" OD x 1.18" and 1.75" OD x .938 pilot)
- Unique pinned alignment shaft allows technician to remove jack to install clutch assembly without obstruction
- Clutch assemblies can be built on the vertical shaft and then positioned easily under the truck
- Patented clutch head assembly (US patents 5,251,875, and 5,033,717)

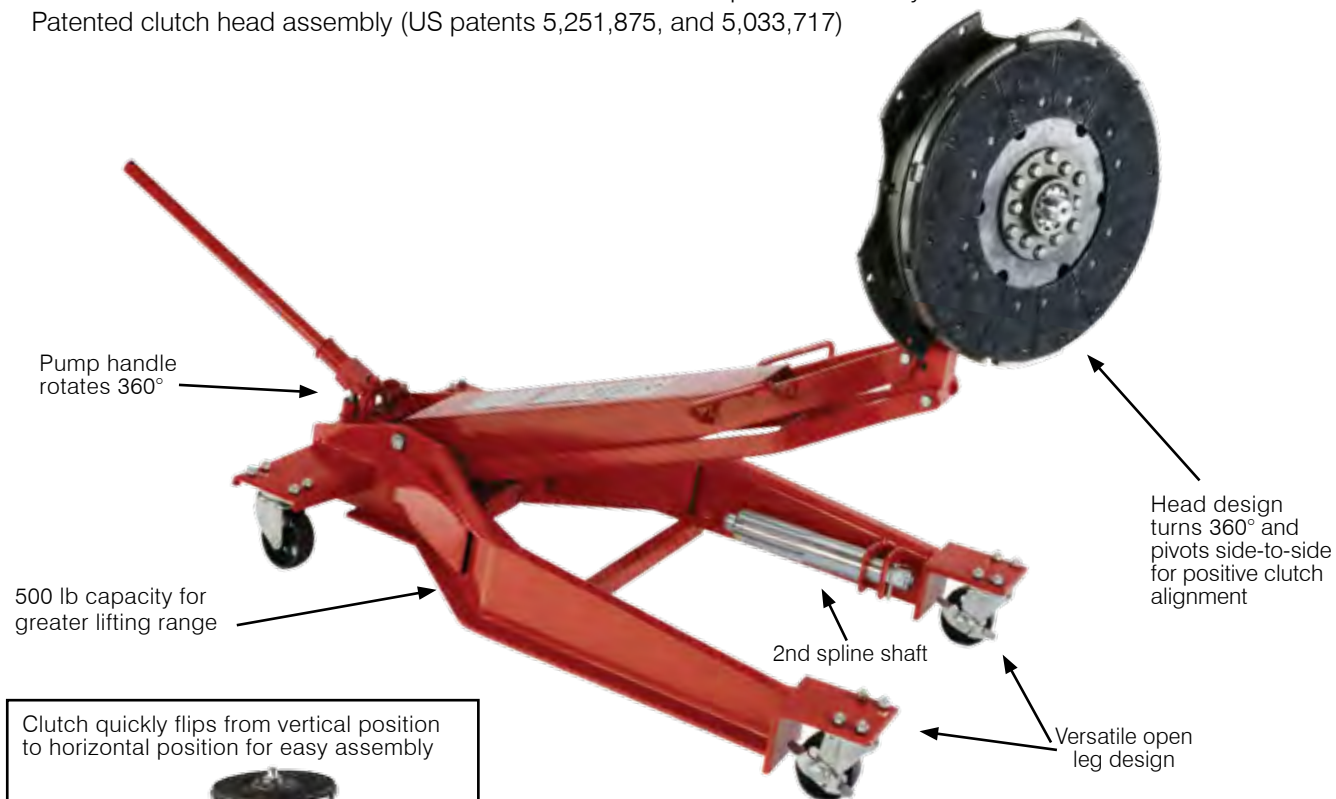

MODEL	CAPACITY (Lbs)	LOW HEIGHT	HIGH HEIGHT	FRAME DIMENSIONS	SHIP WEIGHT
3700	500	13"	39"	36.5" x 22"	139 lbs

**CLUTCH JACK ACCESSORIES**

**FLYWHEEL ADAPTER**

**MODEL 3751**

Easily replaces the spline and bolts onto flat and pot-style truck flywheels used with 14" and 15.5" clutches for more efficient removal and installation.

- Ship weight 6 lbs.



**SPLINED SHAFT**

**MODEL 3749**

- 1.75" OD x 1.18" Pilot
- Ship weight 6 lbs.

**MODEL 3752**

- 1.75" OD x 0.983" Pilot
- Ship weight 6 lbs.

**MODEL 3753**

- 2" OD x 1.18" Pilot
- Ship weight 6 lbs.



**3 TON RATCHETING FARM JACK**

**MODEL 3040A**

- 6,600 lbs lifting capacity
- Versatile ratcheting design is ideal for lifting, pulling, winching, and spreading a tractor or 4-wheel drive vehicle
- Can be used both vertically and horizontally
- Constructed with high-grade steel for extra durability
- Lightweight (32 lbs) and features a 32" long handle with grip

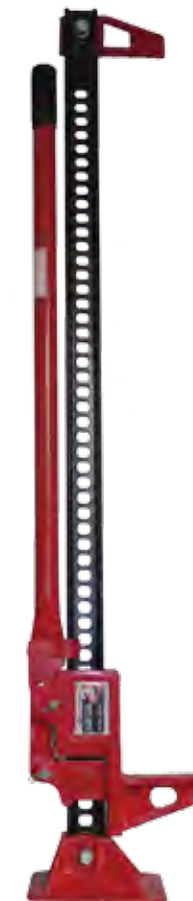

**7 TON FORKLIFT JACK - HEAVY DUTY**

**MODEL 3917**

- Scissors lift from 2.5" to 16.5" for universal coverage of most forklift models
- 14" reach in raised position
- Rugged casters make load alignment easier
- Chassis 26" long x 9" wide
- Safety valve provides critical overload protection



MODEL	CAPACITY (Tons)	LOW HEIGHT	HIGH HEIGHT	REACH	WIDTH	SHIP WEIGHT
3917	7	2.5"	16.5"	14"	9.875"	150 lbs