

11 GALLON PORTABLE AIR TANK

Stock Number W10011

OWNER'S MANUAL



FOR YOUR SAFETY,
please read these instructions carefully and retain them for future use.

Performance
Tool®

SPECIFICATIONS

Capacity..... 11 Gallons
Recommended
operating pressure 85 to 125 P.S.I.
Air hose size 300 P.S.I. Industrial grade
Pressure gauge..... Industrial grade
Canister Heavy Duty MIG Welded Construction

Specifications are subject to change without notice

IMPORTANT SAFETY INFORMATION

WARNING!

READ, UNDERSTAND AND FOLLOW ALL INSTRUCTIONS AND WARNINGS BEFORE OPERATING THIS TOOL. FAILURE TO DO SO MAY RESULT IN PERSONAL INJURY AND/OR PROPERTY DAMAGE AND WILL VOID WARRANTY.

1. Always use eye protection when using tools. If raising dust/debris, wear a suitable mask. Always operate tank in a safe manner, protecting yourself and others in the work area from possible injury.
2. Be sure the tank is under no pressure before removing any of the fittings.
3. Always make sure the pressure gauge/valve assembly, hose and tire chuck are secure, and without damage to allow safe operation of the tank.
4. **DO NOT OVERFILL!** Use tank within its rated capacity and only for its designated purposes. Overfilling air tanks will cause premature wear, permanent damage, injury and/or dangerous situations and will void warranty.
5. **DO NOT** fill from a system charged with more than 150 PSI or from any compressed gas cylinder.
6. Please discard the tank, if the date stamped on the canister has passed.
7. Inspect hoses and fittings for wear and damage prior to using tool. Do not carry or drag tank by the air hose. Keep air hose free from obstruction, twisting and binding. The hose length, which comes standard with this model, will provide the most efficient flow of air and decrease pressure problems in the hose and valves.
8. If a leak should develop in the tank, discard the tank immediately. **DO NOT** weld on any tank designed to contain pressure.

OPERATION

1. This air tank is rated to 125 PSI. Please make a note of the maximum pressure the item you are filling can accommodate.
2. Turn the red On/Off air adjustment dial to ON. This allows the air to flow into the hose from the tank.
3. Press the tire air chuck onto the filling stem of the item you intend to fill until the air flows into the item.
4. When the item is filled or the maximum PSI for the item you are filling is reached, remove the tire air chuck from the filling stem. The tank pressure must exceed the pressure of the item you are filling. If not, the tank will appear to be unable to expel air. Increase the tank pressure, or check that your On/Off air adjustment dial is fully open.
5. After using your air tank, turn the On/Off air adjustment dial to the OFF position. This closes the valve between the tank and the hose and prevents air from leaking from the hose or valves.
6. If the air tank will be sitting unused for a long period of time, expel all the air inside the tank and hose and store in a clean, dry location.

FILLING YOUR PORTABLE AIR TANK

PLEASE NOTE: YOUR PORTABLE AIR TANK MAY BE FILLED AND THE PRESSURE GAUGE MAY BE READ WITH THE AIR ADJUSTMENT DIAL IN THE OFF POSITION.

Fill the tank from a clean, dry, compressed air source to a maximum of 125 PSI. Your local full service gas stations or truck stops provide the best access to ready compressed air sources. This tank is easy to fill. Simply press the chuck from your compressed air source to the fill stem. Watch the needle on the pressure gauge as the tank fills.

DO NOT OVERFILL! Fill your tank until the pressure gauge reads between 85 and 125 PSI, for your safety and the safety of others. Clean air of the correct pressure is recommended for the proper functioning of this air tank.

Check specifications on the item(s) you are inflating or filling for recommended maximum PSI. Water in the air tank and/or air hose contribute to reduced performance and possible damage to your tank and the item you are filling.

MAINTENANCE

Drain water from hoses and compressor tank.

Condensation from the air added to the air tank will accumulate on the inside of the tank. Eventually this may cause rusting which will weaken the welds. Water in the air supply line will cause gumming and power loss. Open the tank and drain water as necessary by turning the canister upside down. Press the needle, using a screwdriver, to drain water from tank. The tank requires a PSI of 10-20 to drain.

Be aware of the destroy date of your tank which is located on the side of the handle.

Be aware of and discard the tank before the destroy date.

REPLACEMENT PARTS LIST

#	Part #	Description
1	W10055	Air Tank Gauge
2	W10056	Air Tank Manifold
3	W10057	4ft. Air Hose with Chuck

PARTS DIAGRAM

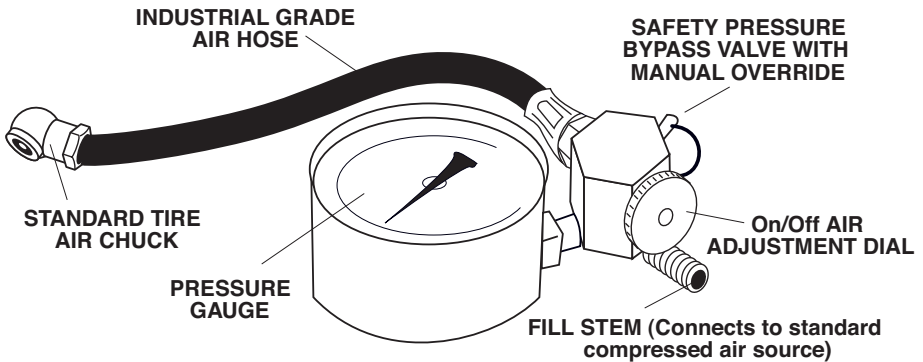

TROUBLESHOOTING

INSUFFICIENT AIR FLOW:

Probable Cause

Solution

Loss of air pressure

Possible leak. Locate by applying soap & water mixture to seams, fittings, etc.

Tank fills slowly

Check opening for obstructions.

Tank won't hold enough air

Clean or replace as necessary or check your air source, make sure it is 125 PSI. Check air pressure at fill stem with a tire gauge. Replace pressure gauge if it does not agree. Or check your air source, make sure it is 85-125 PSI.

Air leakage

Use teflon/thread tape on fittings, hoses and gauge. Check tank for dirty, worn or damaged parts. Replace as necessary.

Gauge won't register/
/registers incorrectly

Be sure that the needle is moving freely by tapping the gauge.

Tank won't accept air
Chuck pin floating
or "crooked"

Fill stem pin may be bent. Replace air manifold.

Turn On/Off air adjustment dial to the ON position. If pin is lodged, tap back of chuck on a hard surface.

Safety pressure bypass
valve seeps air

Pull ring twice to seat with pressure in tank.

LIMITED WARRANTY

PERFORMANCE TOOL® extends only the following warranties, and only to original retail purchasers. These warranties give specific legal rights. Except where prohibited by local law, the law of the State of Washington governs all warranties and all exclusions and limitations of warranties and remedies. There may be other rights which vary from state to state.

PERFORMANCE TOOL® warrants the product to be free from defects in materials and workmanship under normal use and service. A defective product may be returned for a free replacement within 90 days from the date of purchase, provided that product is returned to place of purchase immediately after discovery of defect. After 90 days and up to one year from date of purchase, PERFORMANCE TOOL® will replace at no charge any parts which our examination shall disclose to be defective and under warranty. These warranties shall be valid only when a sales receipt showing the date of purchase accompanies the defective product or defective part(s) being returned. For part(s) after 90 days, please remit your request, postage prepaid to:

PERFORMANCE TOOL, P.O. Box 88259 Tukwila, WA 98138

These warranties exclude blades, bits, punches, dies, bulbs, fuses, hoses, and other consumables which must be replaced under normal use and service. These warranties shall not apply to any product or part which is used for a purpose for which it is not designed, or which has been repaired or altered in any way so as to affect adversely its performance or reliability, nor shall these warranties apply to any product or part which has been subject to misuse, neglect, accident or wear and tear incident to normal use and service.

PERFORMANCE TOOL® does not authorize any other person to make any warranty or to assume any liability in connection with its products.

Except for warranties of title and the limited express warranties set forth above, PERFORMANCE TOOL® makes no express or implied warranties of any kind with respect to its products. In particular, PERFORMANCE TOOL® makes no implied warranty of merchantability and no implied warranty of fitness for any particular purpose, except that for goods purchased primarily for personal, family or household use and not for commercial or business use, PERFORMANCE TOOL® makes an implied warranty of merchantability (and, if otherwise applicable, an implied warranty of fitness for a particular purpose), but only for the particular qualities or characteristics, and for the duration, expressly warranted above.

The laws on limitation of implied warranties may differ from state to state, so the above limitations may not apply in all cases.

PERFORMANCE TOOL® shall not be liable for consequential, incidental or special damages resulting from or in any manner related to any product, or to the design, use, or any inability to use the product. The sole and exclusive remedy for a defective product or part shall be the repair, or replacement thereof as provided above. The laws on limitation of remedies or on consequential, incidental or special damages may vary from state to state, so the above limitations may not apply in all cases.

RÉSERVOIR À AIR PORTATIF DE 42 L

Code d'article W10011

MANUEL DE L'UTILISATEUR



POUR VOTRE SÉCURITÉ,
veuillez lire ces instructions attentivement et les conserver pour toute
référence ultérieure.