

FOR THE MOST SECURE MOUNTING OF THE UNIT, INSTALL ALL MOUNTING SCREWS DIRECTLY TO WALL STUDS. WHEN WALL STUDS CAN NOT BE USED WE RECOMMEND USING HOLLOW WALL ANCHORS.

THE RECOMMENDED MOUNTING HEIGHT OF THE UNIT IS 78" FROM THE FLOOR TO THE TOP OF UNIT.

**MOUNTING INSTRUCTIONS:**

1. SCRIBE A LEVEL LINE ON THE WALL AT 76-7/16" (FIG. 1).
2. SPACE THE HOLES USING THE FOLLOWING CHART:

**MOUNTING HARDWARE (NOT INCLUDED)**



HOLLOW WALL ANCHOR  
#10-24 X 2-1/16"

– MAY BE ACQUIRED FROM LOCAL SOURCE –

NOMINAL UNIT WIDTH	18"	24"	30"	36"	48"	60"	72"	96"
DISTANCE BETWEEN MOUNTING HOLE CENTERS	14-13/16"	20-13/16"	26-13/16"	32-13/16"	43-15/16"	55-15/16"	67-1/16"	92-13/16"

3. DRILL AND INSTALL THE MOUNTING HARDWARE AND ALLOW THE SCREW HEAD TO PROTRUDE 1/4" MAX FROM WALL,
4. HANG UNIT ONTO PROTRUDING SCREW HEADS USING SHEET METAL BRACKETS ON REAR OF UNIT (FIG. 2).

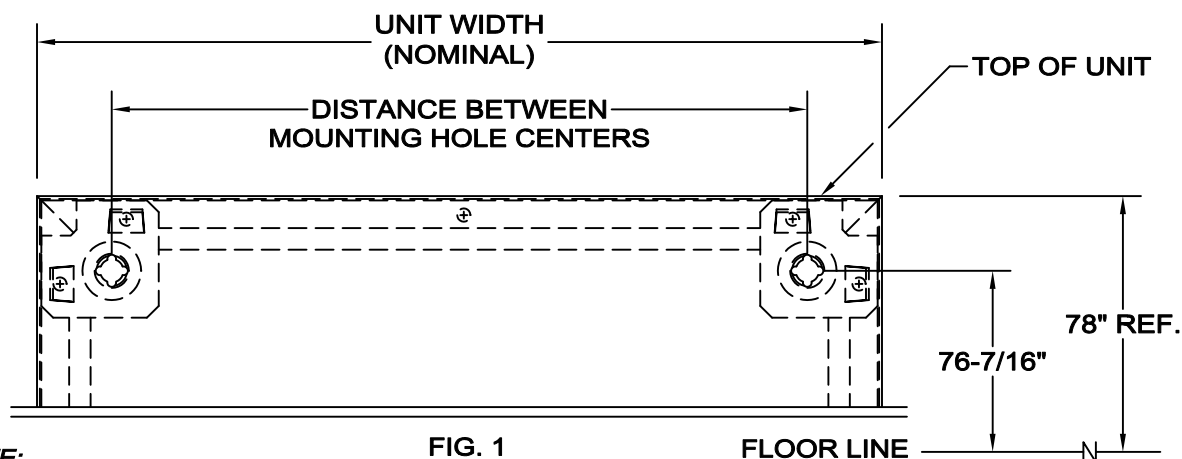
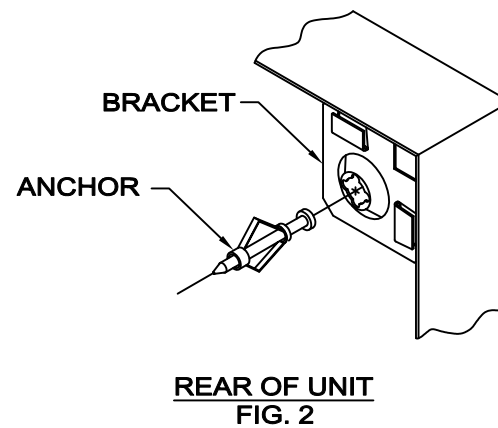

FIG. 1



REAR OF UNIT  
FIG. 2

**NOTE:** TO MOUNT A 96" LONG UNIT, USE THE "L"-HANGERS (PROVIDED) IN ADDITION TO WALL ANCHORS (NOT PROVIDED) AND FOLLOW THE MOUNTING INSTRUCTIONS ENCLOSED WITH IN THE "L"-HANGERS.

**UNITS WITH LIGHTED HEADERS REQUIRE ELECTRICAL INSTALLATION BY A LICENSED ELECTRICIAN. CONSULT YOUR LOCAL ELECTRICAL CODE TO DETERMINE THE CORRECT METHOD OF INSTALLATION.**

**THE LAMPS HAVE BEEN MOUNTED IN THE UNIT, BUT HAVE NOT BEEN WIRED.**

**ACCESS TO THE LAMPS CAN BE MADE BY REMOVING THE REAR PANEL OF THE HEADER SECTION OF THE UNIT.**

**\*\*IMPORTANT\*\*:** UNITS ARE WATER-RESISTANT, NOT WATER-PROOF. WHEN BEING HUNG OUTSIDE, UNIT SHOULD BE UNDER COVER TO PREVENT DAMAGE.

# MESSAGE CENTER INSTRUCTION SHEET

**G H E N T**  
MANUFACTURING INC  
**ISMCT9709**

Your new Ghent Message Center has been assembled and inspected to Ghent's high quality standards. Occasionally during shipment, your message center's door(s) may shift. This shift results in an uneven gap between the door(s) and the body of your unit.

The uneven gap is easily remedied. Mount your unit per the instructions on the opposite side of this sheet. Then simply open the affected door(s) and gently tap the door corner opposite the largest gap (see figure to the right). When you tap the door, be sure to use a rubber mallet or a block of wood and a hammer so the door's finish is not marred. After you've tapped the door corner, close the door and inspect the surrounding gap. If needed repeat the tapping procedure.

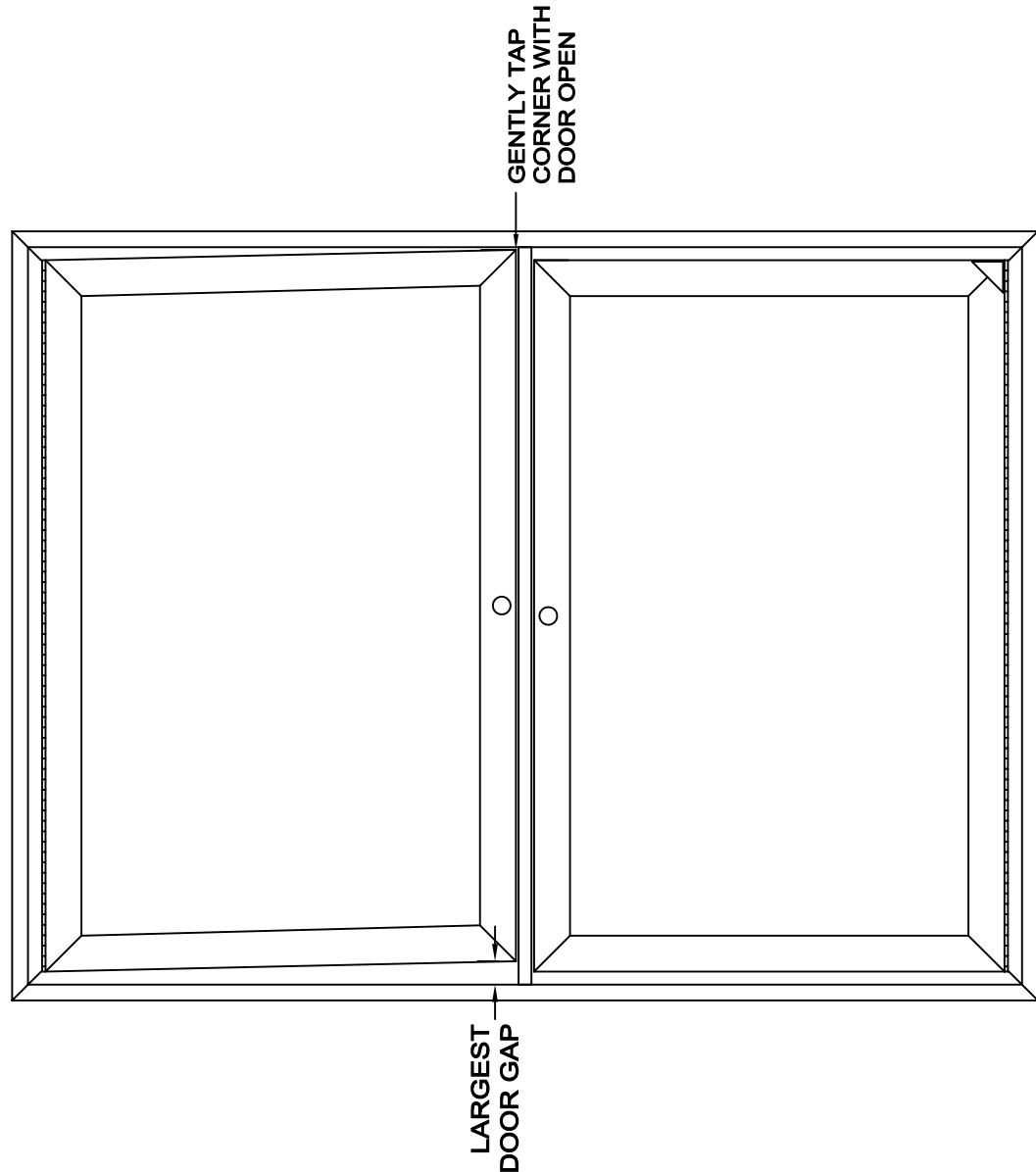

# MESSAGE CENTER INSTRUCTION SHEET

**GHENT**  
MANUFACTURING INC  
ISMCT9709

## Series PA & PB

ENCLOSED BULLETIN, LETTER, & TACK BOARDS

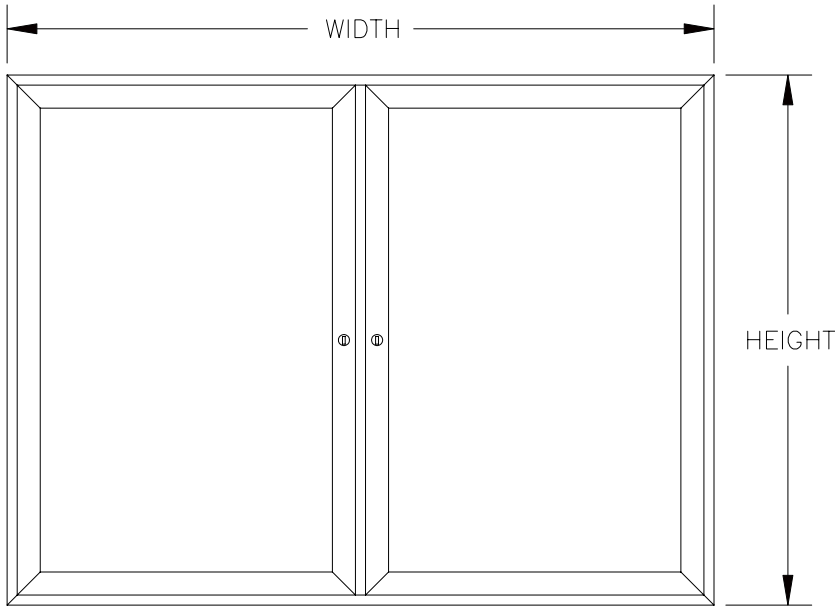

Also available in one and three door models.

3/8" THK. FOR CORK & TACK BOARDS  
1/2" THK. FOR LETTERPANELS  
REF.

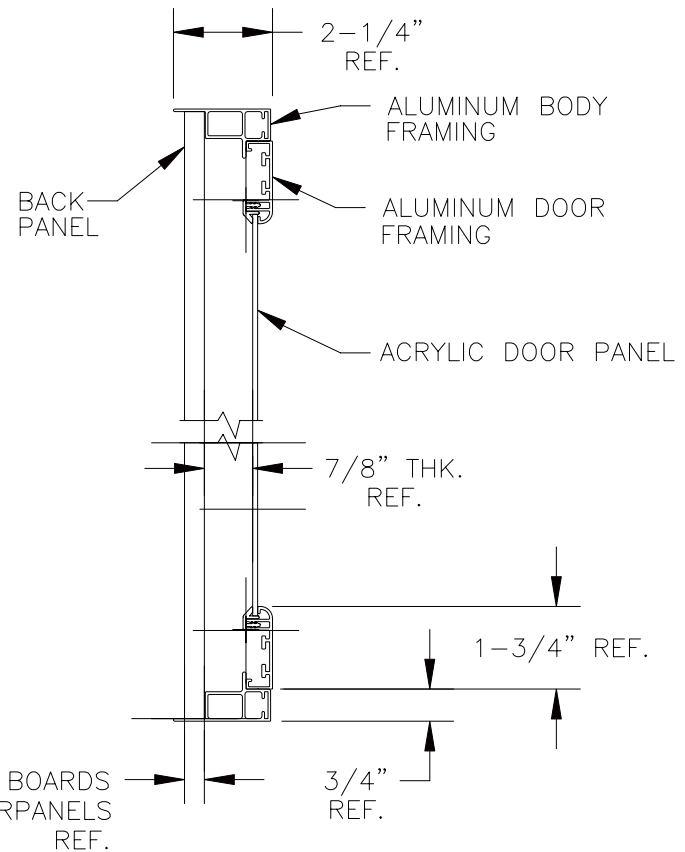

## Specifications:

All exposed metal is to be satin (PA) or bronze (PB) anodized extruded aluminum 6063-T5. Body frame and doors are constructed with mitered corners. Doors have 1/8" thick acrylic panes, continuous hinges and tumble locks with keys. Door frames are self supporting and do not depend on the acrylic panes for strength. The interior panel of the unit can be one of the following: fabric or cork tack board, felt changeable letter panels (for interior use), or vinyl changeable letter panels (for exterior use). Panels for exterior units have foil backing and silicone caulking.

Sizes available:

(1 Door) 24"H x 18"W, 36"H x 24"W, 36"H x 30"W, and 36"H x 36"W  
(2 Door) 36"H x 47-1/8"W, 36"H x 59-1/8"W, and 47-1/8"H x 59-1/8"W  
(3 Door) 36"H x 70-1/4"W, 47-1/8"H x 70-1/4"W, and 47-1/8"H x 96"W

Inside Dimensions:

Overall Width minus 1 3/8" x Overall Height minus 1 3/8" x 7/8" Deep

## Series PAK and PAB

DIRECTORIES AND ENCLOSED BULLETIN BOARDS WITH MODULAR HEADER

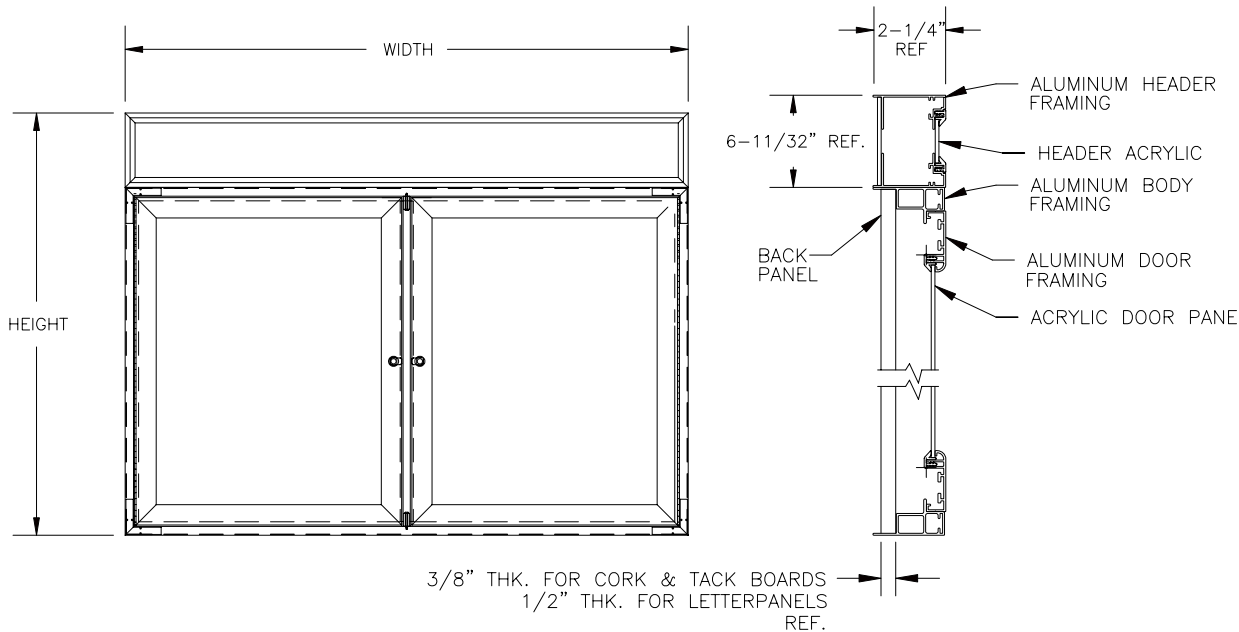

## Specifications

All exposed metal shall be anodized extruded 6063-T5 alloy aluminum. Body shall be assembled with hairline mitered corners. Doors and header shall have 1/8" thick acrylic panes. Doors to be equipped with continuous piano hinge and built-in lock with keys. Door frames are self-supporting and shall not depend on the acrylic panes for strength. The back panel of the case shall be fitted with optional vinyl or cork tackboard panels, felt changeable letter panels for interior use or vinyl changeable letter panels for exterior use. Back panels for exterior units shall have foil backing and silicone caulking. Exterior units are water resistant, not waterproof.

Available sizes:

1-door units: 36"H x 24"W, 36"H x 30"W, and 36"H x 36"W

2-door units: 36"H x 47-1/8"W, 36"H x 59-1/8"W, and 47-1/8"H x 59-1/8"W

3-door units: 36"H x 70-1/4"W, 47-1/8"H x 70-1/4"W, and 47-1/8"H x 96"W

Inside Dimensions:

Overall Width minus 1 3/8" x Overall Height minus 7 23/32" x 7/8"  
Deep

## Series PAKL and PABL

DIRECTORIES AND ENCLOSED BULLETIN BOARDS WITH LIGHTED  
MODULAR HEADER

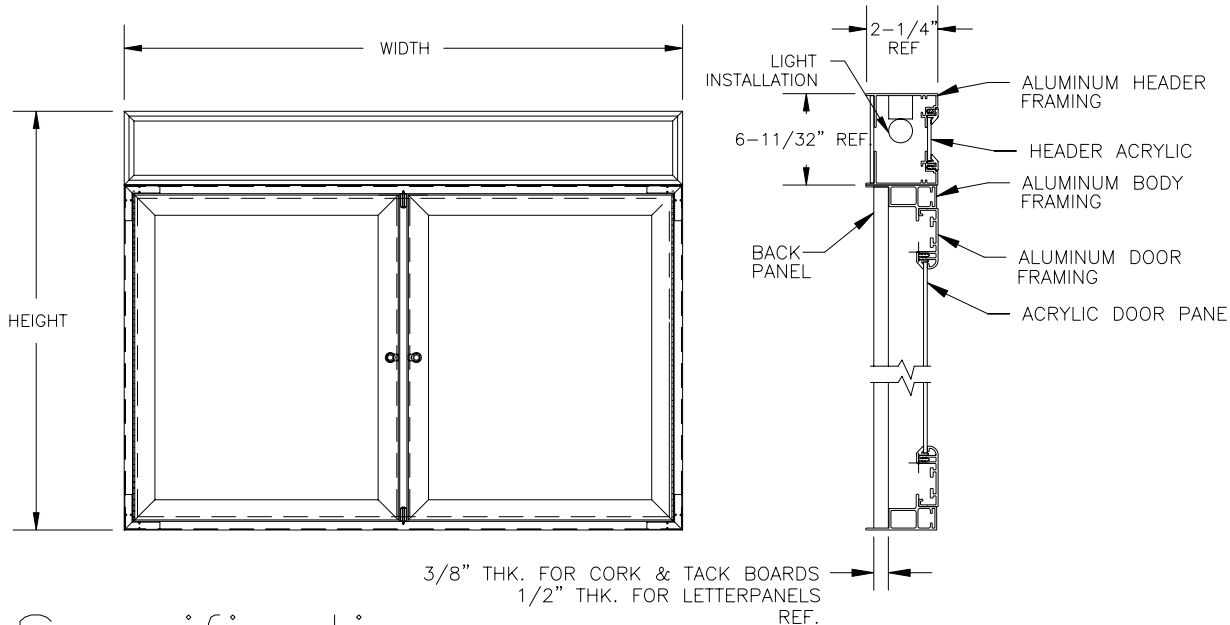

## Specifications

All exposed metal shall be anodized extruded 6063-T5 alloy aluminum. Body shall be assembled with hairline mitered corners. Doors and header shall have 1/8" thick acrylic panes. Doors to be equipped with continuous piano hinge and built-in lock with keys. Door frames are self-supporting and shall not depend on the acrylic panes for strength. The back panel of the case shall be fitted with optional vinyl or cork tackboard panels, felt changeable letter panels for interior use or vinyl changeable letter panels for exterior use. Body back panels for exterior units shall have foil backing and silicone caulking. Header back panels for exterior units shall have mylar backing and weatherstrip tape underneath the panel to block moisture. Exterior units are water resistant, not waterproof. Headers come with light fixture(s) mounted, but not wired. Light(s) are to be wired by a qualified electrician.

Available sizes:

1-door units: 36"H x 24"W and 36"H x 30"W

2-door units: 36"H x 47-1/8"W and 36"H x 59-1/8"W

3-door units: 36"H x 70-1/4"W, 47-1/8"H x 70-1/4"W, and  
47-1/8"H x 96"W

Inside Dimensions:

Overall Width minus 1 3/8" x Overall Height minus 7 23/32" x 7/8"  
Deep

## Recommended Tools:

Pliers - Needle Nosed  
Screwdriver - Medium Flat Blade  
Wallpaper Seam Roller (optional)

## To remove the existing lens:

1. Lay the unit on a flat surface with the lens side facing up.
2. Near one of the mitered corners, insert a screwdriver under the spline where its edge contacts the lens surface. Carefully twist the screw driver to pry the spline up enough to grip it with your fingers or pliers.
3. Peel the remaining spline back out of its mounting channel.
4. Repeat steps 2 and 3 for each of the four spline sections.
5. Tilt the unit up and over to allow the lens to come out.

## To install the new lens:

6. Lay the unit back on a flat surface.
7. Insert the new lens into the unit.
8. Align the mitered edge of one of the new spline sections with the mitered corner of the unit. (Installing the short spline sections first is recommended.)
9. Gently, but firmly, press about a thumbs width of the new spline into the mating channel of the unit.
10. With your thumb, or a wallpaper seam roller, firmly press the rest of the spline section into the mating channel.
11. Repeat steps 8 through 10 for each of the remaining spline sections.
12. Check to see if all spline sections are well seated.

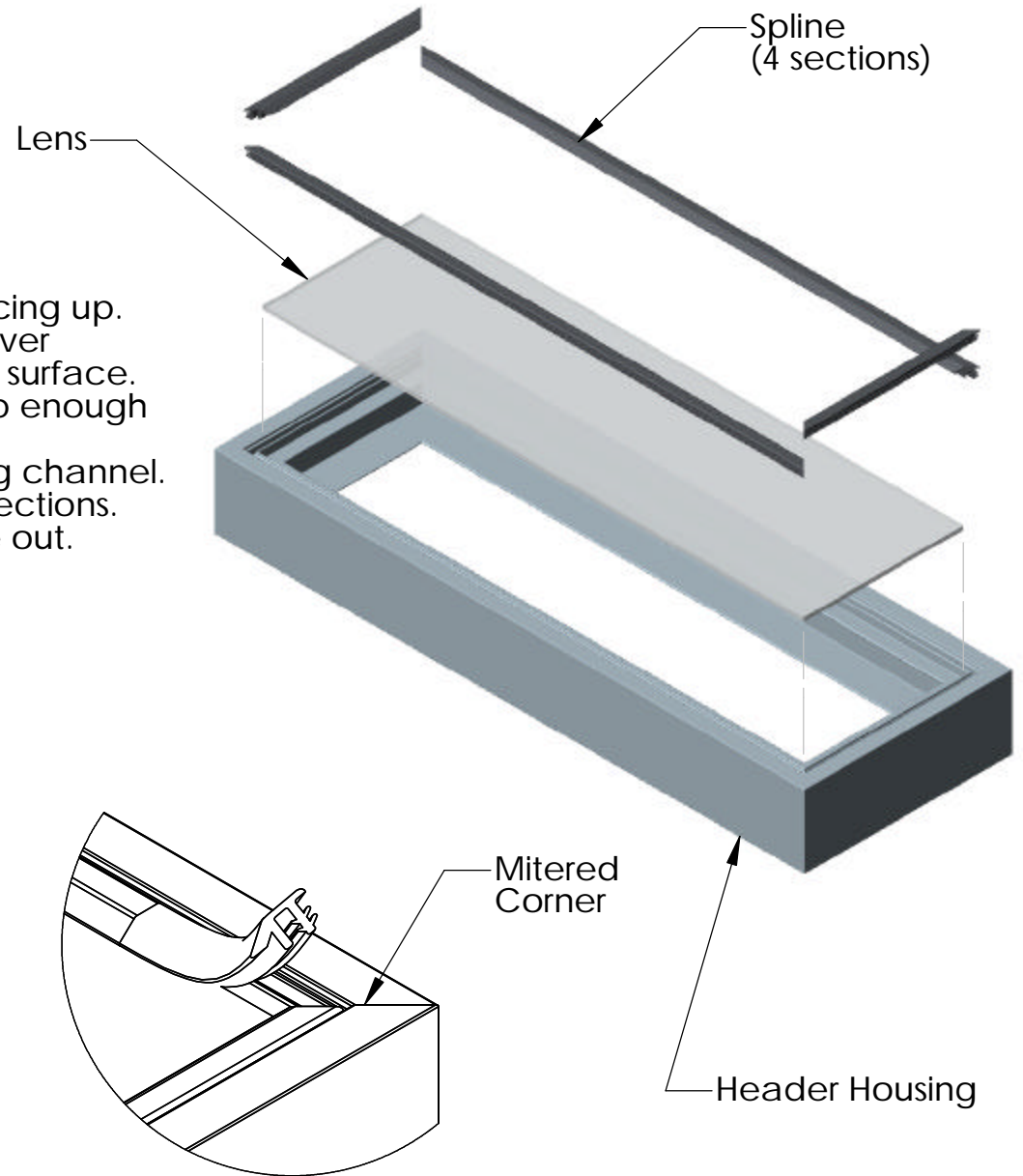

# HEADER LENS REPLACEMENT INSTRUCTION SHEET

**G H E N T**  
MANUFACTURING, INC

IS-RP-HDLENS