

# Air Locker

Model # NT65A2

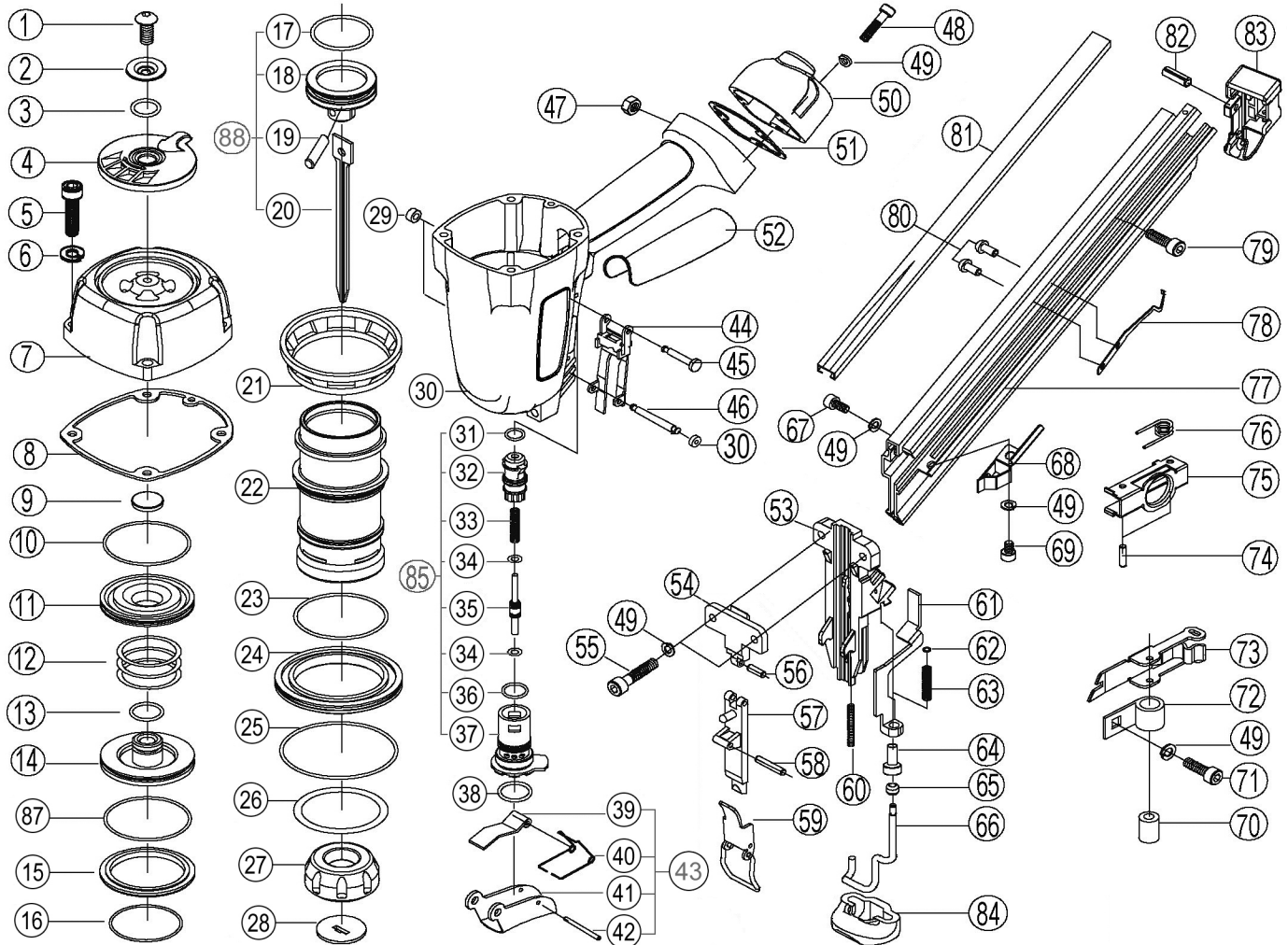

S.No.	DESCRIPTION	Qty.	S.No.	DESCRIPTION	Qty.	S.No.	DESCRIPTION	Qty.	S.No.	DESCRIPTION	Qty.
1	Screw Bolt	1	26	O-ring	1	52	Handle Grip	1	79	Screw Bolt	1
2	Washer	1	27	Bumper	1	53	Driver Guide	1	80	Rivet	2
3	O-ring	1	28	Nozzle	1	54	Spacer	1	81	Nail Guide Rail	1
4	Exhaust Deflector	1	19	Step Pin Retainer	2	55	Screw Bolt	1	82	Cylinder Spring Pin	1
5	Screw Bolt	1	30	Tool Body	1	56	Cylinder Spring Pin	1	83	Mag. End Cover	1
6	Spring Washer	1	85	Trigger Valve Assembly	1	57	Quick Release Cover	1	84	Non-Marring Tip	1
7	Cylinder Cap	1	31	O-ring	1	58	Cylinder Spring Pin	1			
8	Cylinder Cap Gasket	1	32	Trigger Valve Head	1	59	Quick Release Lever	1			
9	Seal, Air	1	33	Compression Spring	1	60	Compression Spring	1			
10	O-ring	1	34	O-ring	1	61	Safety Upper	1			
11	Head Valve	1	35	Trigger Plunging Pin	1	62	O-ring	1			
12	Compression Spring	1	36	O-ring	1	63	Compression Spring	1			
13	O-ring	1	37	Trigger Valve Cage	1	64	Depth Control	1			
14	Head Valve Piston	1	38	O-ring	1	65	Pin Retainer	1			
87	O-ring	1	43	Trigger Valve Set	1	66	Safety Lower	1			
15	Head Valve Piston Bumper	1	39	Trigger Plunging Plate	1	67	Screw Bolt	1			
16	O-ring	1	40	Torsion Spring	1	68	Load-Nail Press Lever	1			
88	Driver Assembly	1	41	Trigger Body	1	69	Screw Bolt	1			
17	O-ring	1	42	Cylinder Spring Pin	1	70	Ribbon Spring Roller	1			
18	Driver Piston	1	44	Safety Guide Frame	1	71	Screw Bolt	1			
19	Driver Piston Pin	1	45	Step Pin	1	72	Ribbon Spring	1			
20	Driver Blade	1	46	Pin	1	73	Nail Pusher	1			
21	Support Collar	1	47	Hex Nut M5	1	74	Cylinder Pin	1			
22	Cylinder	1	48	Screw Bolt	1	75	Nail Pusher Follower	1			
23	O-ring	1	49	Spring Washer	5	76	Torsion Spring	1			
24	Lining Ring Spacer	1	50	Air Inlet End Cover	1	77	Magazine	1			
25	O-ring	1	51	End Cover Gasket	1	78	Spring Plate	1			