

# — Instruction Manual —

## 4 TIER OUTDOOR BLEACHER

Models BLO0704, BLO1504, BLO2104

Aluminum or Galvanized Steel Frame Assembly



Customer Service  
(800) 247-7668

PARTS LIST									
Item	7-1/2' Qty	15' Qty	21' Qty	Description	Item	7-1/2' Qty	15' Qty	21' Qty	Description
A	4	4	4	Dull Aluminum Seat Plank	H	2	3	4	Runner
B	3	3	3	Shiny Aluminum Foot Plank	I	1	2	3	Front Brace
C	9	14	19	3/8-16 x 1 1/4" Hex Bolt	J	2	4	6	Rear Brace
D	8	12	16	3/8" x 2" Carriage Bolt	K	28	42	56	3/8" X 1" Carriage Bolt
E	45	68	91	3/8" Hex Nut	L	14	14	14	Seat End Cap
F	45	68	91	3/8" Lock Washer	M	28	28	28	#10 X 3/4" Sheet Metal Screw
G	28	42	56	Bench Clamp	N	2	3	4	Frame Assembly

NOTE: Extra hardware may be included

- ◆ Inspect all contents prior to installation. Report any missing parts to dealer immediately.
- ◆ Read all instructions before proceeding.

**NOTE: If you have purchased bleacher with galvanized steel frame assemblies**

Prior to assembly check all fastening holes for bolt clearance. On occasion the galvanizing process will partially flow into the fastening holes causing interference. You must remove the excess galvanizing with a power drill, **DO NOT** attempt to pound the fastening hardware through the holes, you will damage the threads and risk injury.

1. Attach a *Runner* (H) to the bottom of each *Frame Assembly* (N) using *3/8" X 2" Carriage Bolts* (D), *3/8" Lock Washers* (F) and *3/8" Hex Nuts* (E). See Figure 1.
2. Position *Frame Assemblies* (N) approximately 72" apart on a level flat surface. Install *Front Brace* (I) using *3/8" X 1 1/4" Hex Bolts* (C), *3/8" Lock Washers* (F) and *3/8" Hex Nuts* (E). See Figure 2.

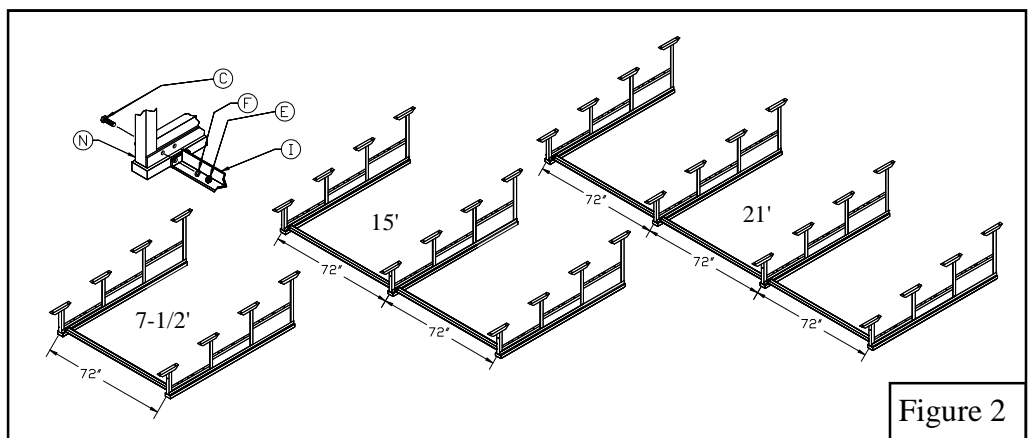
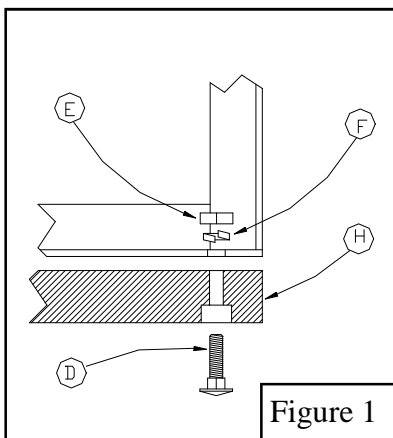

3. Using one each  $3/8''$  X  $1\ 1/4''$  Hex Bolt (C),  $3/8''$  Lock Washer (F) and  $3/8''$  Hex Nut (E) assemble the Rear Braces (J), leave hardware finger tight. See Figure 3.
4. Install Rear Braces (J) to Frame Assemblies (N). Use  $3/8''$  X  $1\ 1/4''$  Hex Bolts (C),  $3/8''$  Lock Washers (F) and  $3/8''$  Hex Nuts (E). The top brace attaches to the fourth hole from the top of frame. The bottom brace attaches to the fifth hole down from the top of the frame. See Figure 3.
5. Attach Dull Aluminum Seat Planks (A) and Shiny Aluminum Foot Planks (B) with  $3/8''$  X  $1''$  Carriage Bolts (K),  $3/8''$  Lock Washers (F),  $3/8''$  Hex Nuts (E) and Bench Clamps (G). Use the mounting holes that are approximately 12'' and 18 1/2'' from the vertical angle on Frame Assembly (N) to attach Shiny Aluminum Foot Planks (B). Each Dull Aluminum Seat Plank (A) and Shiny Aluminum Foot Plank (B) should extend equal distance on both sides from the outside Frame Assemblies (N). Make sure Frame Assemblies (N) are square and parallel to each other prior to tightening hardware. See Figures 4 and 5.
6. Install Seat End Caps (L) with #10 X  $3/4''$  Sheet Metal Screws (M). See Figure 6.
7. Make sure all hardware is tightened prior to use.

