

— Assembly and Safe Use Manual —

BNP0701B/BNP1501B/BNP2101B

7 1/2', 15', 21' Portable Aluminum Player Benches with Backs



Customer Service
(800) 247-7668

PARTS LIST									
Item	7 1/2' Qty	15' Qty	21' Qty	Description	Item	7 1/2' Qty	15' Qty	21' Qty	Description
A	2	4	4	7 1/2' Aluminum Seat Plank	J	4	6	8	Rubber Feet
B	0	0	2	6' Aluminum Seat Plank	K	4	4	4	Seat End Cap
C	2	3	4	Leg Assembly	L	0	4	8	Seat Connector Cap
D	8	12	16	3/8" X 3" Carriage Bolt	M	8	8	8	#10 X 3/4" Sheet Metal Screw
E	4	6	8	3/8" X 1 1/2" Hex Bolt	N	4	6	8	3/8" Flat Washer
F	8	8	8	Bench Clamp	O	0	4	8	Seat Connector Tube
G	12	18	24	3/8" Hex Nut	P	0	16	32	#14 X 3/4" Self Drilling/Threading Hex Screw
H	12	18	24	3/8" Lock Washer	Q	0	1	1	3/8" Hex Magnetic Screw Drive Socket
I	8	12	16	Plastic Tube Plug					

- ◆ NOTE: Extra hardware may be included
- ◆ Inspect all contents prior to installation. Report any missing parts to dealer immediately.
- ◆ Read all instructions before proceeding.

Warning!

While gym floor installers and refinishers often indicate floors are OK to walk or play on in 7-10 days after oil based polyurethane finishes are applied, in reality, it can actually take up to 30 days for all the chemicals in the polyurethane to dissipate. Chemical reactions between the floor finish and certain materials including urethane feet contacting the floor can cause permanent discoloration. Placement of this product on floors prior to the 30-day final cure period may risk discoloration that would not be covered by the manufacturer's warranty.

1. 15' and 21' seat planks are shipped in multiple sections. 15' planks consist of two 7 1/2' *Aluminum Seat Planks* (A). 21' planks consist of one 6' *Aluminum Seat Plank* (B) in the middle with one 7 1/2' *Aluminum Seat Plank* (A) on each end.
2. Plank sections are connected using *Seat Connector Tubes* (O), *Seat Connector Caps* (L), #14 X 3/4" *Self Drilling/Tapping Hex Screws* (P) and 3/8" *Hex Magnetic Screw Drive Socket* (Q).
3. Insert two *Seat Connector Tubes* (O) approximately 5" into the end of each plank that will be attached to an adjoining plank. Using 3/8" *Hex Magnetic Screw Drive Socket* (Q) and a cordless or electric drill install two #14 X 3/4" *Self Drilling/Tapping Hex Screws* (P) through the plank and into each *Seat Connector Tube* (O) located approximately as shown. See Figure 1.
4. Slide two *Seat Connector Caps* (L) back to back over the *Seat Connector Tubes* (O). See Figure 2.

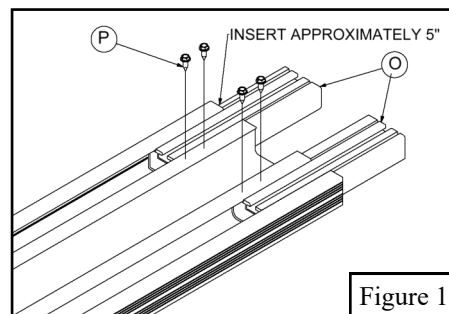

Figure 1

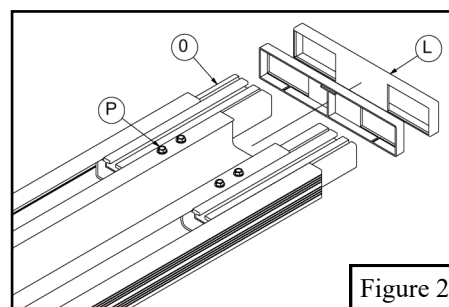
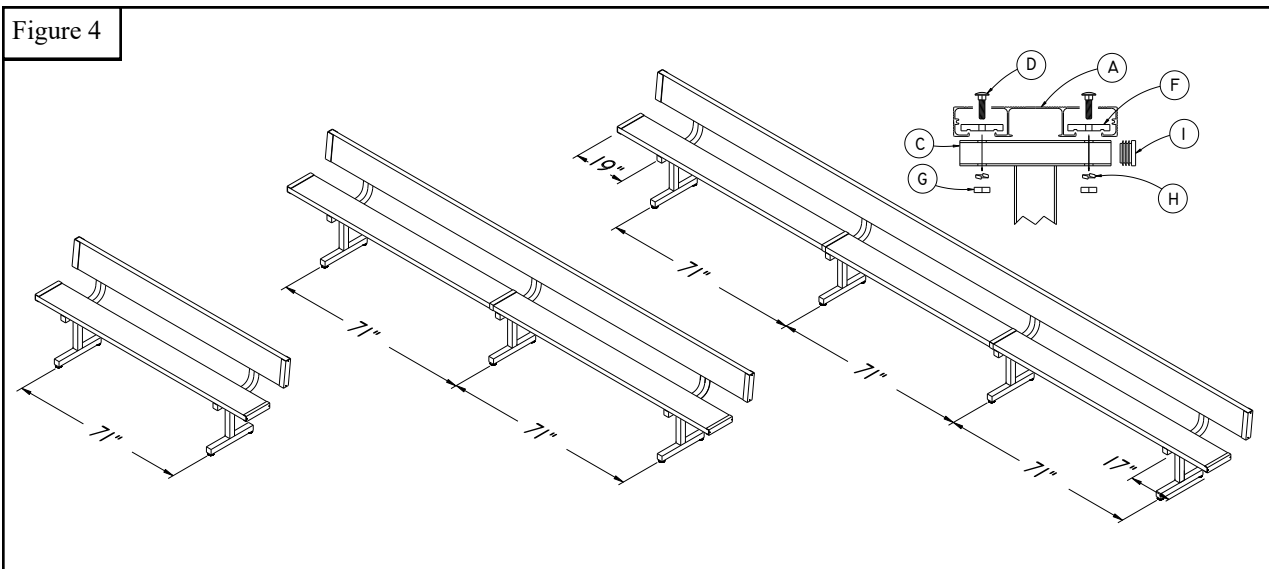
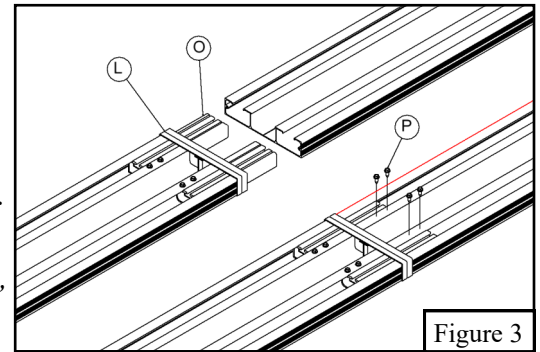

Figure 2

NOTE: These two *Seat Connector Caps* (L) may be replaced in the future by a single double sided *Seat Connector Cap* (L)

5. Position then adjust plank tightly against the mating plank and install two #14 X 3/4" Self Drilling/Threading Hex Screws (P) through the mating plank and into each Seat Connector Tube (O). See Figure 3
6. Repeat this process at each multi-section plank assembly location.
7. Attach Leg Assembly (C) to the seat plank assemblies from above using 3/8" X 3" Carriage Bolts (D), 3/8" Lock Washers (H), 3/8" Hex Nuts (G) and Bench Clamps (F). Use Seat Connector Tube (O) on the center legs in place of Bench Clamps (F). Legs should be spaced 71" center to center with equal plank lengths extending beyond the other legs on 7 1/2' models. On 15' and 21' models the planks will extend beyond the legs more on one end than the other due to the plank connection hardware. See Figure 4.



8. If you want the bench to be portable, attach the Rubber Feet (J) to the Leg Assemblies (C) with 3/8" X 1 1/2" Hex Bolts (E), 3/8" Flat Washers (N), 3/8" Lock Washers (H) and 3/8" Hex Nuts (G). See Figure 5.
9. If you want the bench to be fixed, anchor each Leg Assembly (C) in two places using the appropriated anchors (not included) for the mounting surface. See Figure 5.
10. Insert Plastic Tube Plugs (I) in Leg Assemblies (C). See Figure 4.
11. Install Seat End Caps (K) using #10 X 3/4" Sheet Metal Screws (M). See Figure 6.

