



# Marine 2003-2004 Products and Systems Catalog

*For marine OEM, repair and maintenance professionals*

3M products and systems that improve worker safety, maximize productivity and provide optimal finished results



---

## To Search:

You can easily search by product number using the search feature of Acrobat Reader. (Binoculars Tool or Menu. . .Edit. . .Search. . .Query. . .)



*Note:* The search will stop at the first instance the product number appears in the document. Simply repeat the search to find other instances.

You can also select (mouse click) any item in the part index to automatically jump to that item in the catalog. Use the bookmarks at left to jump to the catalog indexes.

---

## To View:

At anytime you can enlarge or shrink the view size of the PDF by changing the percentage at the bottom of the window. Type in a percentage or choose one of the pre-set views from the pop-up window.

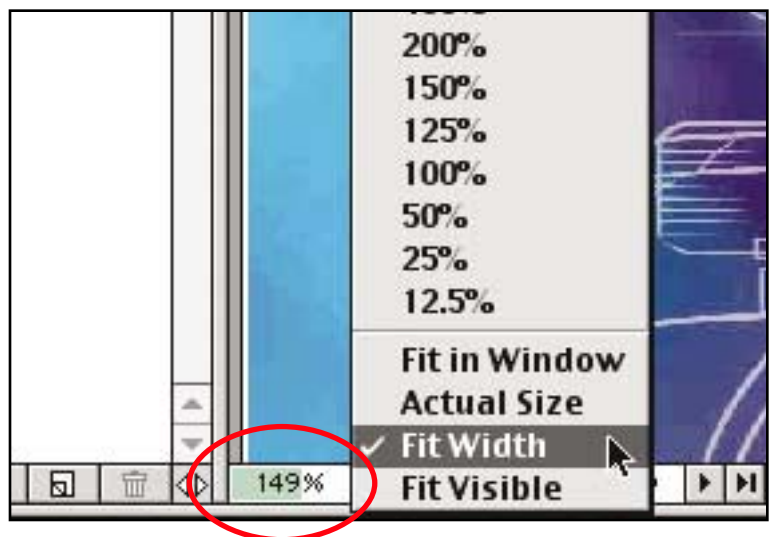



## QUICK REFERENCE

**Abrasives** ..... 6-72, 84-85

**Fiberglass Fillers** ..... 73-75

**Wax and Maintenance** ..... 76-77, 88-90

**Compounds, Glazes and Polishes** ..... 78-83, 86-87, 91-94

**Cleaning** ..... 95-106

**Tapes and Masking Systems** ..... 107-129

**Adhesives, Sealants and Fastening Systems** ..... 130-142

**Safety and Respirators** ..... 145-185

**Electrical** ..... 186-194



# 3M Marine Product Index

## ABRASIVES AND ACCESSORIES

Accessories	
Blocks.....	33-34, 37, 42
Fairing Boards.....	35
Glue-On Discs.....	27-28
Grinding Discs.....	58-60
Hookit™ Discs.....	23-26
Hookit™ Dust-Free Discs.....	55-57
Hookit™ Sheets.....	37
Hookit™ II Discs.....	21-22
Hookit™ II Dust-Free Discs.....	53-54
Hookit™ II Sheets.....	34
Roloc™.....	60
Scotch-Brite™.....	65-67
Stikit™ Discs.....	20
Stikit™ Dust-Free Discs.....	52
Stikit™ Sheets & Sheet Rolls.....	32-33
Surface Conditioning.....	66-67
Wetordry™.....	38-39
Belts.....	45
Bristle Brushes & Discs.....	68
Cloth Utility Rolls.....	43
Cut-Off Wheels.....	61
Discs	
Adhesive.....	21
Floor Surfacing.....	36
Glue On.....	27-28
Grinding.....	58-60
Hookit™.....	23-26
Hookit™ Dust-Free.....	55-57
Hookit™ II.....	21-22
Hookit™ II Dust-Free.....	53-54
Racks.....	44
Scotch-Brite™.....	65-67
Stripe Removal – Scotch-Brite™.....	65
Surface Conditioning Discs – Scotch-Brite™.....	66-67
Stikit™.....	14-18
Stikit™ Dust-Free.....	50-52
Dry Sanding	
Accessories – Discs.....	52
Accessories – Dust-Free.....	52
Accessories – Sheets & Sheet Rolls.....	37, 42
Discs.....	27-29
Dust-Free Discs.....	55-57
Sheet Rolls.....	32
Sheets.....	35, 39-41
Fairing Board System.....	35
Flexible Grinding Discs.....	62
Floor Surfacing Discs & Rolls.....	36
Glue-On Sanding Discs.....	27-28
Grinding Discs – Fibre, Cloth, Roloc™.....	58-59
Grinding Wheels.....	61-62
Hand Pads – Scotch-Brite™.....	63-64
Hookit™	
Accessories – Discs.....	26
Accessories – Dust-Free.....	57
Accessories – Sheets & Sheet Rolls.....	37

Discs.....	23-25
Dust-Free Discs.....	55-56
Fairing Boards & Abrasives.....	35
Sheets.....	37, 56
Hookit™ II	
Accessories – Discs.....	22
Accessories – Dust-Free.....	54
Accessories – Sheets & Sheet Rolls.....	34
Discs.....	21
Dust-Free Discs.....	53
Sheets.....	21, 34
Professional Packaged Abrasives.....	69
Racks & Organizers.....	44
Retail Packaged Abrasives & Accessories.....	69-72

## ADHESIVES/SEALANTS

101 Sealant.....	132
5200 Adhesive/Sealant.....	131
Adhesive/Sealants, Start-Up Deals.....	131-132
Adhesives.....	134-136
Adhesives, Applicators and Accessories.....	131-133
Adhesives, Retail Packaged.....	138
Aerosol Adhesives.....	137
Bulk Spray Adhesives.....	136
Fast Cure 4200 Adhesive/Sealant.....	131
Fast Cure 5200 Adhesive/Sealant.....	131
Marine Grade Silicone Sealant.....	132
Scotch® Mini Weld Adhesive System.....	136

## ANTI-SLIP SURFACE MATERIALS

.....	174-176
-------	---------

## ANTI-FATIGUE MATTING

.....	177
-------	-----

## BILGE PILLOW, OIL AND FUEL ABSORBENT

.....	172-173
-------	---------

## BOAT RECONDITIONING AND MAINTENANCE PRODUCTS

Aluminum Restorer and Polish.....	89
Cleaner and Wax.....	88
Metal Restorer and Polish.....	89
Restorer and Wax.....	88
Vinyl Cleaner, Conditioner and Protector.....	89
Waxes.....	88-89

## BOAT SOAP

.....	90, 97
-------	--------

## BRISTLE BRUSHES & DISCS

.....	68
-------	----

## BUFFING AND POLISHING PADS

.....	93-94
-------	-------

# 3M Marine Product Index

## CABLE TIES

.....192-193

## CARPET CLEANER, PROTECTOR

.....98

## CLEANERS

Adhesive .....98  
 Bathroom .....101  
 Boat Soap .....90, 97  
 Body Shop Clean-Up™ Products .....102  
 Carpet and Rug .....98  
 Citrus Base Cleaner .....99  
 Choke and Carburetor .....143  
 Copper and Brass .....98  
 Fiberglass .....96  
 Floor .....101  
 Glass .....98  
 Hand .....168  
 Metal .....95  
 Sharpshooter .....101  
 Silver .....98  
 Stainless Steel Cleaner and Polish .....99  
 Twist 'n Fill™ Cleaning Chemical  
 Management System .....106  
 Upholstery .....98  
 Vinyl .....96

## CLEANER AND WAX

.....88

## COATING, ELECTRICAL

.....190

## COMMAND ADHESIVES

.....139

## COMPOUNDS, GLAZES, POLISHES AND WAXES

Accessories  
 Backup Pads .....94  
 Finesse-It™ Roloc™ Finishing Pads .....94  
 Perfect-It™ Backup Pad .....94  
 Superbuff™ Adaptor .....93  
 Buffing Pads  
 Finesse-It™ 3" Natural Buffing Pad .....94  
 Hookit™ SBS™ Pads .....93  
 Perfect-It™ Foam Polishing Pad .....94  
 Superbuff™ Buffing Pad .....93  
 Superbuff™ 2 Plus 2 Pad .....93  
 Superbuff™ III Buffing Pad .....93  
 Superbuff™ III 2 Plus 2 Pad .....93  
 Superbuff™ III Rounded Edge Foam  
 Compounding Pad – 8" .....93  
 Superbuff™ Polishing Pad .....93  
 Compounds  
 Finesse-It™ Marine Paste Compound .....91  
 Finesse-It™ II Finishing Material .....92

High Gloss Gelcoat Compound .....91  
 Imperial™ Compound and Finishing Material .....91  
 Imperial™ Microfinishing Compound .....91  
 Perfect-It™ III Compounds .....91  
 Premium Mold & Tooling Compound .....91  
 Super Duty Rubbing Compound .....91  
 Finesse-It™ Marine Paste Compound .....91  
 Finesse-It™ II Finishing Material .....92  
 Glazes  
 Imperial™ Hand Glaze .....92  
 Imperial™ Machine Glaze .....92  
 Finesse-It™ II Finishing Material .....92  
 Perfect-It™ Foam Polishing Pad Glaze .....92  
 Perfect-It™ III Glazes .....92  
 High Gloss Gelcoat Compound .....91  
 Hookit™ SBS™ System  
 Backup Pad .....93  
 Compounding Pad .....93  
 Polishing Pad .....93  
 Imperial™ Compound and Finishing Material .....91  
 Imperial™ Hand Glaze .....92  
 Imperial™ Machine Glaze .....92  
 Imperial™ Microfinishing Compound .....91  
 Perfect-It™  
 Foam Polishing Pad .....94  
 Foam Polishing Backup Pad .....94  
 Foam Polishing Pad Glaze .....92  
 Wax and Glaze Wipes .....92  
 Perfect-It™ III  
 Extra Cut Rubbing Compound .....91  
 Finishing Glaze .....92  
 Machine Glaze .....92  
 Rubbing Compound .....91  
 Premium Mold & Tooling Compound .....91  
 Super Duty Rubbing Compound .....91  
 Wipes – Perfect-It™ Wax & Glaze .....92

## CONNECTORS, ELECTRICAL

.....190-191

## CUT-OFF WHEELS

.....61

## 3M™ DOODLEBUG™ MAINTENANCE AND CLEANING MATERIALS

.....99-100

## DRY GUIDE COAT

.....44

## EAR PROTECTION

.....164-165

## ELECTRICAL PRODUCTS

Cable Ties .....192-193  
 Cold Shrink™ Tubing .....189  
 Connectors .....190-191

# 3M Marine Product Index

Empty 3M™ Scotchlok™ Terminal Boxes .....	191
Heat Shrink Tubing.....	188
Retail Packaged Products.....	194
Tapes, Dispensers and Coatings .....	186-187, 190
Terminals.....	190-192

<b>FASTENERS, RECLOSEABLE</b>	
.....	140-142

<b>FASTENING SYSTEMS</b>	
3M™ Dual Lock™ Fastening Systems .....	141-142
3M™ Scotchmate™ Hook-and-Loop Fastening Systems .....	140-141

## FIBERGLASS MAINTENANCE (SEE BOAT RECONDITIONING)

<b>FIBERGLASS FILLERS AND ACCESSORIES</b>	
Crème Hardeners .....	73-74
High Strength Repair Filler.....	73
Lightweight Body Filler .....	74
Mechanical Dispenser.....	74
Premium Filler .....	73
Scotchlite™ Glass Bubbles.....	75
Spreaders .....	73
Zebra™ Advanced Lightweight Filler.....	74

<b>FLOOR AND DECK MATTING</b>	
.....	178-182

<b>FOAM TAPES</b>	
.....	121-122

<b>FLUID RECOVERY PRODUCTS</b>	
Bilge Pillow .....	172
Sorbents .....	172-173
Spill Kit.....	172-173

<b>GASKET</b>	
Adhesives.....	132, 134, 138
Form-In-Place .....	134-135
Removal, Surface Conditioning Discs .....	66-67

<b>GLASS BUBBLES, 3M™ SCOTCHLITE™</b>	
.....	75

## GLUE (SEE ADHESIVES/SEALANTS)

<b>GRINDING</b>	
Discs .....	58-60
Wheels.....	61-62

<b>HAND CLEANER</b>	
.....	168

<b>HAND PADS</b>	
.....	63-64

<b>HANG TABS</b>	
.....	195

<b>HEARING PROTECTION</b>	
.....	164-165

<b>HEAT SHRINK TUBING</b>	
.....	188

<b>LAMINATING SYSTEMS</b>	
.....	196

<b>LUBRICANTS</b>	
4-Way™ Spray .....	143
Brake Lube/Anti-Seize .....	143
Choke and Carburetor Cleaner.....	143
Lithium Lubricant .....	143
Penetrant .....	143
Release Agent.....	135
Silicone Lubricant Plus .....	143
Silicone Paste.....	143

<b>MASKS AND RESPIRATORS</b>	
.....	146-163

<b>MASKING FILMS AND PAPERS</b>	
.....	124-127

<b>MASKING MACHINES</b>	
.....	128

## MASKING TAPE (SEE TAPES)

<b>MATS AND MATTING</b>	
Floor .....	178-182
Deck .....	178-182
Anti-Fatigue .....	177

<b>MECHANICAL SEALANTS AND ADHESIVES</b>	
.....	138

<b>METAL CLEANERS</b>	
Brass and Copper .....	98
Silver .....	98
Metal Restorer and Polish.....	95

<b>NOMAD™ MATTING PRODUCTS</b>	
.....	178-181

## OIL/GASOLINE CLEAN UP (SEE FLUID RECOVERY PRODUCTS)

# 3M Marine Product Index

<b>OIL SPILL KIT</b>	172-173
<b>PAINT AND VARNISH REMOVER AND ACCESSORIES</b>	144
<b>PAINT PREPARATION SYSTEM</b>	105
<b>PENETRANTS</b>	143
<b>PERSONAL CARE PRODUCTS</b>	
Ultrathon™ Insect Repellent	168
<b>POLISHES</b>	95
<b>POST-IT® QUALITY FLAG</b>	195
<b>PUTTIES</b>	75
<b>REFERENCE AND APPLICATION CHARTS (SEE PAGE 5)</b>	
<b>REFLECTIVE PRODUCTS, 3M™ SCOTCHLITE™</b>	182-183
<b>RESPIRATORS (SEE ALSO SAFETY PRODUCTS)</b>	146-163
<b>RESTORER AND WAX</b>	88
<b>RETAIL PACKAGED PRODUCTS</b>	
Abrasives, Marine Professional	69-72
Adhesives/Sealants	138
Boat Reconditioning and Maintenance Products	88-90
Electrical	194
Point of Sale Displays	196
Safety Products	169-171
Sandpaper Racks	44
Sponges and Wipes	69, 100
Tape	124
<b>RUBBING COMPOUNDS (SEE COMPOUNDS)</b>	
<b>SANDING BELTS, DISCS, ROLLS, SHEETS AND ACCESSORIES (SEE ABRASIVES)</b>	

<b>SAFETY PRODUCTS</b>	
Air Monitoring Systems	155-159
Comfort Masks	169
Ear Muffs	164-165
Ear Plugs	164
Eye Protection	166-167
Face Protection	166-167
First Aid Kits	168
Fit Test Apparatus and Accessories	163
Floor and Deck Matting Products and Accessories	178-182
Head Protection	166
Lenses, 3M™ Vanguard™	184
Respirator Cleaning Wipes	163
Respirator Compliance Software	163
Respirators/Filters	145-163
Retail Packaged Safety Products	169-171
Self Contained Breathing Apparatus (SCBA)	162
Slip Resistant Products	174-176
<b>SCOTCH-BRITE™ HAND PADS</b>	63-64
<b>SCOTCHGARD™</b>	
Rug and Carpet Cleaner	98
Fabric Protector	98
Outdoor Fabric Protector	98
Upholstery Cleaner and Protector	98
<b>SCOURING PADS</b>	63-64
<b>SCRUBBERS</b>	101
<b>SEALANTS</b>	
Gasket	132, 134, 138
Marine	131
Marine Grade Silicone	132
Pipe Thread Tape	121
<b>SHEETS</b>	
Sanding	39-42
Sorbents	172-173
<b>SORBENTS</b>	172-173
<b>SPREADERS</b>	73
<b>SPONGES</b>	
Cleaning	100-101
Sanding	42, 69
<b>STRIPE REMOVAL DISCS</b>	65

# 3M Marine Product Index

## SURFACE CONDITIONING

.....66-67

## TAPES

Adhesive Transfer Tapes .....120  
 Box Sealing Tapes .....117, 120  
 Dispensers .....123  
 Duct and Cloth Tapes .....116  
 Filament Strapping Tapes .....118  
 Foam and Paper Tapes .....121-122  
 General Purpose Tapes .....119  
 Masking Tapes .....108  
 Packaging Tapes .....118  
 Packing List Tapes .....119  
 Painting Tape .....110  
 Paint Striping Tapes .....109  
 Pipe Thread Sealant Tape .....121  
 Protective and Chafing Tapes .....111-115  
 Retail Packaged Tapes .....124  
 SCPM-44X Protective Tape .....115  
 Weather Resistant Tapes .....110

## TERMINALS, ELECTRICAL

.....190-192

## THINSULATE™ MARINE INSULATION

.....185

## TIES, CABLE

.....192-193

## TUBING, HEAT SHRINK

.....188

## VACUUM ASSIST ABRASIVES

*Accessories* Hookit™ .....26, 37, 57  
 Hookit™ II .....22, 34, 54  
 Stikit™ .....20, 33, 52

*Discs* Hookit™ .....23-25  
 Hookit™ II .....21  
 Stikit™ .....14-18  
*Sheets* Hookit™ .....37, 56  
 Hookit™ II .....21, 34

## VANGARD™ LENSES

.....184

## VARNISH AND PAINT REMOVER AND ACCESSORIES

.....144

## VINYL MAINTENANCE

.....96

## WAXES

.....95

## WELDING PRODUCTS

Drape .....129  
 Grinding Wheel .....61-62  
 Respirator .....146-163  
 Welding and Spark Deflection Paper and Dispenser .....129

## WHEELS

Cut-Off .....61  
 Grinding .....61-62

## WIPES, CLEANERS

.....92, 100, 163

## WIRE MARKERS

.....187

## REFERENCE AND APPLICATION CHARTS

9" x 11" Sheet Availability Grid .....31	Preferred Buffing Techniques .....86
Abrasive Application Chart .....84	Preferred Gelcoat Finishing System .....80
Boat Reconditioning and Maintenance Products .....76-77	Preferred Machine Sanding Techniques .....85
Buffing and Polishing Pads .....87	Preferred Masking Tapes .....107
Dust-Free Sanding Discs and Sheets Availability Grid .....46-49	Preferred Oxidation Finishing System .....78
Fiberglass Repair Product Recommendation .....73	Preferred Paint Finishing System .....79
Helpful Hints for Plastic Reconditioning Systems .....82	Preferred Respiratory Protection .....145
Preferred Abrasive Sanding Discs .....6-8	Sanding Discs Availability Grid .....9-13
Preferred Acrylic Plastic Finishing System .....83	Sheet and Sheet Roll Availability Grid .....29-30
Preferred Adhesives and Sealants .....130	Surface Protection Products .....112
Preferred Brightwork Finishing System .....81	Thinsulate™ Sound and Thermal Insulation .....185



## 3M Marine Preferred Sanding Discs for Paint Preparation

### 5" DISCS

Grit	Hookit™ Brand			Stikit™ Brand			Hookit™ II Brand		
	Product I.D.	Part Number	Product Type	Product I.D.	Part Number	Product Type	Product I.D.	Part Number	Product Type
P1500	260L	00951	Finishing Film				260L	00851	Finishing Film
P1200	260L	00952	Finishing Film	260L	83681	Finishing Film	260L	00852	Finishing Film
P1000	260L	00953	Finishing Film	260L	83680	Finishing Film	260L	00853	Finishing Film
P800	260L	00954	Finishing Film	260L	83679	Finishing Film	260L	00854	Finishing Film
P600	260L	00955	Finishing Film	260L	83778	Finishing Film	260L	00855	Finishing Film
P500	334U	01756	Imperial™ Discs	334U	00298	Imperial™ Discs	334U	00656	Imperial™ Discs
P400	334U	01757	Imperial™ Discs	334U	00299	Imperial™ Discs	334U	00657	Imperial™ Discs
P360				334U	00300	Imperial™ Discs	334U	00658	Imperial™ Discs
P320	334U	01759	Imperial™ Discs	334U	00301	Imperial™ Discs	334U	00659	Imperial™ Discs
P280	334U	01760	Imperial™ Discs	334U	00302	Imperial™ Discs	334U	00660	Imperial™ Discs
P240	334U	01761	Imperial™ Discs	334U	00303	Imperial™ Discs	334U	00661	Imperial™ Discs
P220	334U	01762	Imperial™ Discs	334U	00304	Imperial™ Discs	334U	00662	Imperial™ Discs
P180	734U	01763	Imperial™ Discs	734U	00305	Imperial™ Discs	734U	00663	Imperial™ Discs
P150	734U	01764	Imperial™ Discs	734U	00306	Imperial™ Discs	734U	00664	Imperial™ Discs
P120	734U	01765	Imperial™ Discs	734U	00307	Imperial™ Discs	734U	00665	Imperial™ Discs
P100	734U	01766	Imperial™ Discs	734U	00308	Imperial™ Discs	734U	00666	Imperial™ Discs
P100E				745I	00365	Imperial™ Discs			
P80	734U	01767	Imperial™ Discs	734U	00309	Imperial™ Discs	734U	00667	Imperial™ Discs
80E	745I	01728	Imperial™ Discs	745I	00366	Imperial™ Discs	745I	00828	Imperial™ Discs
60E	740I	01770	Imperial™ Discs	740I	00381	Imperial™ Discs			
40E	740I	01729	Imperial™ Discs	740I	00367	Imperial™ Discs	740I	00829	Imperial™ Discs
36E	740I	01730	Imperial™ Discs	740I	00368	Imperial™ Discs	740I	00830	Imperial™ Discs

# 3M Marine Preferred Sanding Discs for Paint Preparation

## 6" DISCS

Grit	Hookit™ Brand			Stikit™ Brand			Hookit™ II Brand		
	Product I.D.	Part Number	Product Type	Product I.D.	Part Number	Product Type	Product I.D.	Part Number	Product Type
P1500	260L	00950	Finishing Film				260L	00850	Finishing Film
P1200	260L	00968	Finishing Film	260L	01318	Finishing Film	260L	00868	Finishing Film
P1000	260L	00969	Finishing Film	260L	01319	Finishing Film	260L	00869	Finishing Film
P800	260L	00970	Finishing Film	260L	01320	Finishing Film	260L	00870	Finishing Film
P600	260L	00971	Finishing Film	260L	01321	Finishing Film	260L	00871	Finishing Film
P600	255L	00999	Gold Film	255L	01311	Gold Film			
P500	334U	01771	Imperial™ Discs	334U	00322	Imperial™ Discs	334U	00672	Imperial™ Discs
P400	334U	01772	Imperial™ Discs	334U	00323	Imperial™ Discs	334U	00673	Imperial™ Discs
P360				334U	00324	Imperial™ Discs	334U	00674	Imperial™ Discs
P320	334U	01774	Imperial™ Discs	334U	00325	Imperial™ Discs	334U	00675	Imperial™ Discs
P280	334U	01775	Imperial™ Discs	334U	00326	Imperial™ Discs	334U	00676	Imperial™ Discs
P240	334U	01776	Imperial™ Discs	334U	00327	Imperial™ Discs	334U	00677	Imperial™ Discs
P220	334U	01777	Imperial™ Discs	334U	00328	Imperial™ Discs	334U	00678	Imperial™ Discs
P180	734U	01778	Imperial™ Discs	734U	00329	Imperial™ Discs	734U	00679	Imperial™ Discs
P150	734U	01779	Imperial™ Discs	734U	00330	Imperial™ Discs	734U	00680	Imperial™ Discs
P120	734U	01780	Imperial™ Discs	734U	00331	Imperial™ Discs	734U	00681	Imperial™ Discs
P100	734U	01781	Imperial™ Discs	734U	00332	Imperial™ Discs	734U	00682	Imperial™ Discs
P80	734U	01782	Imperial™ Discs	734U	00333	Imperial™ Discs	734U	00683	Imperial™ Discs
P80E	745I	01733	Imperial™ Discs	745I	00371	Imperial™ Discs	745I	00833	Imperial™ Discs
60E	740I	01773	Imperial™ Discs	740I	00372	Imperial™ Discs			
40E	740I	01734	Imperial™ Discs	740I	00373	Imperial™ Discs	740I	00834	Imperial™ Discs
36E	740I	01735	Imperial™ Discs	740I	00374	Imperial™ Discs	740I	00835	Imperial™ Discs

## 3M Marine Preferred Sanding Discs for Fairing and Paint Preparation

### 8" DISCS

Grit	Hookit™ Brand			Stikit™ Brand			Hookit™ II Brand		
	Product I.D.	Part Number	Product Type	Product I.D.	Part Number	Product Type	Product I.D.	Part Number	Product Type
P500				216U	01483	Gold Film	334U	00656	Imperial™ Discs
P400				334U	00395	Imperial™ Discs	334U	00657	Imperial™ Discs
P320	255L	00984	Gold Film	334U	00396	Imperial™ Discs	334U	00684	Imperial™ Discs
P240				334U	00397	Imperial™ Discs			
P220	255L	00985	Gold Film				334U	00685	Imperial™ Discs
P180	255L	00986	Gold Film	734U	00399	Imperial™ Discs	734U	00686	Imperial™ Discs
P150	255L	00987	Gold Film	734U	00400	Imperial™ Discs	734U	00687	Imperial™ Discs
P120	255L	00988	Gold Film	734U	00401	Imperial™ Discs	734U	00688	Imperial™ Discs
P120E							745I	00836	Imperial™ Discs
P100				734U	00402	Imperial™ Discs			
P100E							745I	00837	Imperial™ Discs
100E	750U	00520	Green Corps™						
P80	255L	00990	Gold Film	734U	00402	Imperial™ Discs	734U	00690	Imperial™ Discs
P80E				745I	00377	Imperial™ Discs	745I	00843	Imperial™ Discs
80D	745I	01743	Imperial™ Discs						
60E	740I	01768	Imperial™ Discs	740I	00378	Imperial™ Discs			
40E	740I	01744	Imperial™ Discs	740I	00379	Imperial™ Discs	740I	00844	Imperial™ Discs
36E	740I	01745	Imperial™ Discs	740I	00380	Imperial™ Discs	740I	00845	Imperial™ Discs
24E	255U	01652	Green Corps™ Fre-Cut™ Discs	246U	01552	Green Corps™ Fre-Cut™ Discs			

# 3M™ Stikit™ Sanding Discs Availability Grid



Size and Grade	3M™ Imperial™ Stikit™ Disc Rolls 360L	3M™ Imperial™ Stikit™ Disc Rolls 334U & 734U	3M™ Imperial™ Stikit™ Discs 740I & 745I	3M™ Stikit™ Gold Film Disc Rolls 255L	3M™ Stikit™ Finishing Film Discs 260L	3M™ Stikit™ Gold "C" Weight Disc Rolls 236U (Non-Staining Fre-Cut™)	3M™ Stikit™ Gold Disc Rolls 216U	3M™ Green Corps™ Stikit™ Production™ Discs 246U & 251U	3M™ Stikit™ Imperial™ Resin Bond Disc Rolls 363I
5" 1500									
1200					83681				
1000					83680				
800	06222				83679		01215		
600	06221			84753	83678		01214		
500	06220	00298		82460		86497	01417		
400	06219	00299		82461		86496	01419		
360	06218	00300					01418		
320	06217	00301		82463		86495	01420		
280	06216	00302		82464			01421		
240	06214	00303		82465		86494	01422		
220	06213	00304		82466		86493	01423		
180		00305		82467		86492	01424		21795
150		00306		82468		86491	01425		21796
120		00307		82469		86490	01426		21797
100		00308		82470		86489	01427		21798
80		00309	00366	82471		86488	01428	01501 *	21799
60			00381						21800
40			00367					01545	
36			00368					01546	

\* Fre-Cut™ Discs

# 3M™ Stikit™ Sanding Discs Availability Grid

Size and Grade	3M™ Imperial™ Stikit™ Disc Rolls 360L	3M™ Imperial™ Stikit™ Disc Rolls 334U & 734U	3M™ Imperial™ Stikit™ Discs 740I & 745I	3M™ Stikit™ Gold Film Disc Rolls 255L	3M™ Stikit™ Finishing Film Discs 260L	3M™ Stikit™ Gold "C" Weight Disc Rolls 236U (Non-Staining Fre-Cut™)	3M™ Stikit™ Gold Disc Rolls 216U	3M™ Green Corps™ Stikit™ Production™ Discs 246U 251U & 255U	3M™ Stikit™ Imperial™ Resin Bond Disc Rolls 363I
6" 1500									
1200					01318				
1000					01319				
800	14003***				01320		01217		
600	14004***			01311	01321		01216		
500	14005***	00322		01322		86477	01202/01432*		
400	14006***	00323		01323		86476	01203/01434*		
360	14007***	00324		01324			01204/01433*		
320	14008***	00325		01325		86475	01205/01435*		
280	14009***	00326		01326			01206/01436*		
240	14010***	00327		01327		86474	01207/01437*		
220	14011***	00328		01328		86473	01208/01438*		
180		00329		01329		86472	01439		21789
150		00330		01330		86471	01440		21790
120		00331	00369	01331		86470	01441		21791
100		00332		01332		86469	01442		21792
80		00333	00371	01333		86468	01443	01506**	21793
60			00372						21794
40			00373					01547	
36			00374						
8" 600				01336					
500							01483		
400		00395					01484		
320		00396					01485		
240		00397					01487		
220							01488		
180		00399					01489		21783
150		00400					01490		21784
120		00401	00375				01491		21785
100		00402					01492		21786
80		00403	00377				01493	01549**	21787
60			00378					01556**	21788
40			00379					01550	
36			00380					01551	
24								01552**	

\* Denotes difference in discs/roll

\*\* Fre-Cut™ Discs

\*\*\* Available as a KUT item

# 3M™ Hookit™ II and Hookit™ Sanding Discs Availability Grid

Size and Grade	3M™ Hookit™ Imperial™ Disc Rolls 360L	3M™ Imperial™ Hookit™ Disc Rolls 334U & 734U	3M™ Imperial™ Hookit™ Discs 740I & 745I	3M™ Hookit™ Finishing Film Discs 260L	3M™ Hookit™ Gold Film Discs 255L	3M™ Hookit™ Gold Discs 216U	3M™ Green Corps™ Hookit™ Production™ Fre-Cut™ Discs 255U	3M™ Green Corps™ Hookit™ Regalite™ Discs 750U & 751U	3M™ Imperial™ Hookit™ II Discs 334U & 734U	3M™ Imperial™ Hookit™ II Discs 740I & 745I	3M™ Hookit™ II Finishing Film Discs 260L
3" 1500				00907							
1200				00908							
1000				00909							
800				00910							
600				00911							
500					00912						
400					00913						
320					00914						
240					00915						
220					00916						
180					00917						
150					00918						
120					00919						
100					00920						
80					00921						
5" 1500				00951							00851
1200				00952							00852
1000				00953							00853
800	55722			00954		86300					00854
600	55721			00955	00998	86299					00855
500	55720	01756			00956				00656		
400	55719	01757			00957				00657		
360	55718				00958				00658		
320	55717	01759			00959				00659		
280	55716	01760			00960				00660		
240	55714	01761			00961				00661		
220	55713	01762			00962				00662		
180		01763			00963				00663		
150		01764			00964				00664		
120		01765			00965				00665		
100		01766			00966			00506	00666		
80		01767	01728		00967			00507	00667	00828	
60			01770					00508			
40			01729					00509		00829	
36			01730					00510		00830	

# 3M™ Hookit™ II and Hookit™ Sanding Discs Availability Grid

Size and Grade	3M™ Hookit™ Imperial™ Disc Rolls 360L	3M™ Imperial™ Hookit™ Disc Rolls 334U & 734U	3M™ Imperial™ Hookit™ Discs 740I & 745I	3M™ Hookit™ Finishing Film Discs 260L	3M™ Hookit™ Gold Film Discs 255L	3M™ Hookit™ Gold Discs 216U	3M™ Green Corps™ Hookit™ Production™ Fre-Cut™ Discs 255U	3M™ Green Corps™ Hookit™ Regalite™ Discs 750U & 751U	3M™ Imperial™ Hookit™ II Discs 334U & 734U	3M™ Imperial™ Hookit™ II Discs 740I & 745I	3M™ Hookit™ II Finishing Film Discs 260L
6"	1500			00950							00850
	1200			00968							00868
	1000			00969							00869
	800	13936*		00970							00870
	600	13937*		00971	00999						00871
	500	13938*	01771		00972				00672		
	400	13939*	01772		00973				00673		
	360	13940*			00974				00674		
	320	13941*	01774		00975				00675		
	280	13942*	01775		00976				00676		
	240	13943*	01776		00977				00677		
	220	13944*	01777		00978				00678		
	180		01778		00979				00679		
	150		01779		00980				00680		
	120		01780		00981				00681		
	100		01781		00982			00511	00682		
	80		01782	01733	00983			00512	00683	00833	
	60			01773				00513			
	40			01734				00515		00834	
	36			01735				00516		00835	
8"	600										
	500										
	400										
	320					00984			00684		
	240										
	220					00985			00685		
	180					00986			00686	00836	
	150					00987			00687	00837	
	120					00988			00688	00843	
	100							00520	00689		
	80		01743		00990			00521	00690	00844	
	60		01768				01656	00522		00845	
	40		01744					00524			
	36		01745					00525			
	24						01652				

\* Available as a KUT item

# Accessory Availability Grid



Shape	Durometer	Size	Stikit™	Stikit™ Dust-Free	Hookit™	Hookit™ Dust-Free	Hookit™ II	Hookit™ II Dust-Free
<b>5" &amp; 6" Pads:</b>								
Standard	Hard	5" x 3/4" x 5/16"-24	05575	45217	05775	82659	05275	n/a
		6" x 3/4" x 5/16"-24	05576	45218	05776	05876	05276	09352
Standard (painters)	Medium	5" x 3/4" x 5/16"-24	n/a	n/a	n/a	n/a	n/a	n/a
		6" x 3/4" x 5/16"-24	n/a	n/a	n/a	n/a	05286	n/a
Low Profile	Hard	5" x 3/8" x 5/16"-24	05555	05655	05755	05855	05255	05355
		6" x 3/8" x 5/16"-24	05556	05656	05756	05856	n/a	05356
Low Profile Finishing (primer pad)	Soft	5" x 11/16" x 5/16"-24	05545	05645	77855	77856	05245	05345
		6" x 11/16" x 5/16"-24	05546	05646	05747	n/a	05251	05351
Interface Pad	Soft	5" x 1/2" x 1"	n/a	n/a	05773	05773	05273	05273
		6" x 1/2" x 1"	n/a	n/a	05774	05774	05274	05274
Hand Pad (rounded ends)	Hard	5" x 1/4"	05585	n/a	n/a	n/a	n/a	n/a
		6" x 1/4"	05586	n/a	n/a	n/a	n/a	n/a
Hand Pad	Soft	5" x 1/4"	45189	n/a	77752	n/a	85088	n/a
		6" x 1/4"	05591	n/a	05791	n/a	05291	n/a
Half Round Pad	Medium	5" x 1/4"	n/a	n/a	n/a	n/a	n/a	n/a
		6" x 1/4"	n/a	n/a	05792	n/a	05292	n/a
<b>8" Pads:</b>								
Standard	Hard	8" x 1" x 5/8"-11 INT	05579	n/a	05779	n/a	05279	n/a
Soft Pad	Soft	8" x 1" x 5/8"-11 INT	05568	n/a	05768	n/a	05268	n/a
Pad-National-Detroit 900	Hard	8" x 3/8" - 5 holes	05581	05681	05781	05881	05281	05381
Pad-Hutchins tool	Hard	8" 3/8" - 5/8"-11 INT	n/a	n/a	n/a	n/a	05280	05380
Pad-Chicago Pneumatic 777	Hard	8" x 3/8" - 6 holes	05582	05682	05782	n/a	05280	05382
<b>Sheet Accessories:</b>								
Hand Block	Hard	2 3/4" x 5"	05440	n/a	05740	n/a	05240	n/a
Hand Block	Hard	2 3/4" x 7 3/4"	05441	n/a	05741	n/a	05241	n/a
Soft Hand Block	Soft	2 3/4" x 5"	05442	n/a	05742	n/a	05242	n/a
Hand File Board	Hard	2 3/4" x 16 1/2"	05444	n/a	05744	n/a	05244	n/a
Stikit™ Hand Pads	Soft	2 3/4" x 5"	05530	n/a	n/a	n/a	n/a	n/a
WOD Hand Pads	Medium	2 3/4" x 5"	05526	n/a	n/a	n/a	n/a	n/a
Fairing Board - Rigid	Hard	4 1/2" x 30"	n/a	n/a	83497	n/a	n/a	n/a
Fairing Board - Flexible	Hard	4 1/2" x 30"	n/a	n/a	83978	n/a	n/a	n/a
Air File Shoe	Hard	2 3/4" x 16 1/2"	05548	n/a	05748	05848	05248	05348
Orbital Air File Shoe	Hard	3 3/4" x 16 1/2"	05546	n/a	n/a	n/a	05246	n/a
<b>Dispensers:</b>								
DA Disc Dispenser	n/a	5" & 6" - Small rolls	05451	05451	n/a	n/a	n/a	n/a
DA Disc Dispenser	n/a	5" & 6" - Large rolls	05450	05450	n/a	n/a	n/a	n/a
Sheet Roll Dispenser	n/a	2 3/4" wide	05452	n/a	n/a	n/a	n/a	n/a
Sheet Roll Dispenser	n/a	4 1/2" wide	00403	n/a	n/a	n/a	n/a	n/a

5666 (Stikit™ Discs with removable center studs)

5757 (Hookit™ Discs for gear)

5366 (Hookit II™ Discs with removable center studs)



# 3M™ Stikit™ Sanding Discs

## 3M™ Imperial™ Stikit™ Disc Rolls 334U and 734U

This product earns the 3M Purple color which indicates the latest 3M technology, greatest cost/value and highest quality available. 3M™ Imperial™ Stikit™ Disc Rolls 334U and 734U are high-performance discs designed to cut faster and last longer enabling the user to obtain maximum usage from each disc. The 334U discs (grades P220-P500) are constructed of a high-performance aluminum oxide mineral, and the 734U discs (P80-P180) are constructed of a uniquely blended mineral. Both mineral systems are excellent for use on tough marine gelcoat, paint and primer systems.



## 3M™ Imperial™ Stikit™ Disc Rolls 360L

This product earns the 3M Purple color which indicates the latest 3M technology, greatest cost/value and highest quality available. 3M™ Imperial™ Stikit™ Disc Rolls 360L are high-performance discs designed to cut faster and last longer on composite substrates enabling the user to obtain maximum usage from each disc.

Part Number	Product I.D.	Grade	Size	Discs Per Roll	Rolls Per Case
NEW 051131-00298	334U	P500	5"	75	4
NEW 051131-00299	334U	P400	5"	75	4
NEW 051131-00300	334U	P360	5"	75	4
NEW 051131-00301	334U	P320	5"	75	4
NEW 051131-00302	334U	P280	5"	75	4
NEW 051131-00303	334U	P240	5"	75	4
NEW 051131-00304	334U	P220	5"	75	4
NEW 051131-00305	734U	P180	5"	75	4
NEW 051131-00306	734U	P150	5"	75	4
NEW 051131-00307	734U	P120	5"	75	4
NEW 051131-00308	734U	P100	5"	75	4
NEW 051131-00309	734U	P80	5"	75	4
NEW 051131-00322	334U	P500	6"	75	4
NEW 051131-00323	334U	P400	6"	75	4
NEW 051131-00324	334U	P360	6"	75	4
NEW 051131-00325	334U	P320	6"	75	4
NEW 051131-00326	334U	P280	6"	75	4
NEW 051131-00327	334U	P240	6"	75	4
NEW 051131-00328	334U	P220	6"	75	4
NEW 051131-00329	734U	P180	6"	75	4
NEW 051131-00330	734U	P150	6"	75	4
NEW 051131-00331	734U	P120	6"	75	4
NEW 051131-00332	734U	P100	6"	75	4
NEW 051131-00333	734U	P80	6"	75	4
051131-00395	334U	P400	8"	100	4
051131-00396	334U	P320	8"	100	4
051131-00397	334U	P240	8"	100	4
051131-00399	734U	P180	8"	100	4
051131-00400	734U	P150	8"	100	4
051131-00401	734U	P120	8"	100	4
051131-00402	734U	P100	8"	100	4
051131-00403	734U	P80	8"	100	4

Part Number	Product I.D.	Grade	Size	Discs Per Box	Boxes Per Case
NEW 051135-06222	360L	P800	5"	125	4
NEW 051135-06221	360L	P600	5"	125	4
NEW 051135-06220	360L	P500	5"	125	4
NEW 051135-06219	360L	P400	5"	125	4
NEW 051135-06218	360L	P360	5"	125	4
NEW 051135-06217	360L	P320	5"	125	4
NEW 051135-06216	360L	P280	5"	125	4
NEW 051135-06214	360L	P240	5"	125	4
NEW 051135-06213	360L	P220	5"	125	4
NEW 051135-14003	360L	P800	6"	125	4
NEW 051135-14004	360L	P600	6"	125	4
NEW 051135-14005	360L	P500	6"	125	4
NEW 051135-14006	360L	P400	6"	125	4
NEW 051135-14007	360L	P360	6"	125	4
NEW 051135-14008	360L	P320	6"	125	4
NEW 051135-14009	360L	P280	6"	125	4
NEW 051135-14010	360L	P240	6"	125	4
NEW 051135-14011	360L	P220	6"	125	4

Note: 6" available as a KUT item.

## 3M™ Imperial™ Stikit™ Discs 740I and 745I

This product earns the 3M Purple color which indicates the latest 3M technology, greatest cost/value and highest quality available. This uniquely blended mineral construction and tough "E" weight backing provides for a fast cutting, longer lasting abrasive. Excellent for stripping paint or sanding marine fairing compounds.



Part Number	Product I.D.	Grade	Size	Discs Per Box	Boxes Per Case
051131-00366	745I	P80E	5"	50	4
051131-00381	740I	60E	5"	50	4
051131-00367	740I	40E	5"	50	4
051131-00368	740I	36E	5"	50	4
051131-00369	745I	P120E	6"	50	4
051131-00371	745I	P80E	6"	100	4
051131-00372	740I	60E	6"	50	4
051131-00373	740I	40E	6"	50	4
051131-00374	740I	36E	6"	50	4
051131-00375	745I	P120E	8"	25	4
051131-00377	745I	P80E	8"	25	4
051131-00378	740I	60E	8"	25	4
051131-00379	740I	40E	8"	25	4
051131-00380	740I	36E	8"	25	4

# 3M™ Stikit™ Sanding Discs

## 3M™ Stikit™ Gold Film Disc Rolls 255L

3M™ Stikit™ Gold Film Disc Rolls 255L are designed for high-performance use on tougher to sand Marine paint, gelcoat and primer systems. This pressure-sensitive adhesive disc is constructed of a high-performance aluminum oxide mineral strongly bonded to a smooth film backing. Cuts fast, lasts long and leaves a consistent finish.



Part Number	Product I.D.	Grade	Size	Discs Per Roll	Rolls Per Case
051144- <b>84753</b>	255L	P600	5"	100	5
051144- <b>82460</b>	255L	P500	5"	125	4
051144- <b>82461</b>	255L	P400	5"	125	4
051144- <b>82463</b>	255L	P320	5"	125	4
051144- <b>82464</b>	255L	P280	5"	125	4
051144- <b>82465</b>	255L	P240	5"	125	4
051144- <b>82466</b>	255L	P220	5"	125	4
051144- <b>82467</b>	255L	P180	5"	125	4
051144- <b>82468</b>	255L	P150	5"	125	4
051144- <b>82469</b>	255L	P120	5"	125	4
051144- <b>82470</b>	255L	P100	5"	125	4
051144- <b>82471</b>	255L	P80	5"	100	4
051131- <b>01311</b>	255L	P600	6"	125	4
051131- <b>01322</b>	255L	P500	6"	75	6
051131- <b>01323</b>	255L	P400	6"	75	6
051131- <b>01324</b>	255L	P360	6"	75	6
051131- <b>01325</b>	255L	P320	6"	75	6
051131- <b>01326</b>	255L	P280	6"	75	6
051131- <b>01327</b>	255L	P240	6"	75	6
051131- <b>01328</b>	255L	P220	6"	75	6
051131- <b>01329</b>	255L	P180	6"	75	6
051131- <b>01330</b>	255L	P150	6"	75	6
051131- <b>01331</b>	255L	P120	6"	75	6
051131- <b>01332</b>	255L	P100	6"	75	6
051131- <b>01333</b>	255L	P80	6"	75	6
051131- <b>01336</b>	255L	P600	8"	50	5

## 3M™ Stikit™ Finishing Film Discs 260L

3M™ Stikit™ Finishing Film Discs 260L are designed for use in scuff sanding before painting, as well as to remove runs, dust nibs, and excess orange peel from paint and gelcoat prior to compounding. These discs allow for machine sanding versus having to hand sand prior to compounding or using very aggressive compounds (multiple applications of). These 3M™ Stikit™ discs are individually lined and constructed of a high-performance, aluminum oxide mineral bonded to a smooth film pressure-sensitive adhesive backing. Cuts fast, lasts long, resists loading and leaves a consistent finish.



Part Number	Product I.D.	Grade	Size	Discs Per Box	Boxes Per Case
051144- <b>83681</b>	260L	P1200	5"	100	4
051144- <b>83680</b>	260L	P1000	5"	100	4
051144- <b>83679</b>	260L	P800	5"	100	4
051144- <b>83678</b>	260L	P600	5"	100	4
051131- <b>01318</b>	260L	P1200	6"	100	4
051131- <b>01319</b>	260L	P1000	6"	100	4
051131- <b>01320</b>	260L	P800	6"	100	4
051131- <b>01321</b>	260L	P600	6"	100	4

# 3M™ Stikit™ Sanding Discs

## 3M™ Stikit™ Gold Disc Rolls 216U

These discs are aggressive, sharp, fast cutting and long lasting. Their construction also resists dulling, loading and edge wear. The pressure-sensitive adhesive coating ensures excellent adhesion to 3M™ Stikit™ disc pads without adhesive buildup.



## 3M™ Stikit™ Gold Disc Rolls 216U (continued)



Part Number	Product I.D.	Grade	Size	Discs Per Roll	Rolls Per Case
051131-01215	216U	P800	5"	100	4
051131-01214	216U	P600	5"	100	4
051131-01417	216U	P500	5"	175	6
051131-01419	216U	P400	5"	175	6
051131-01418	216U	P360	5"	175	6
051144-01420	216U	P320	5"	175	6
051144-01421	216U	P280	5"	175	6
051144-01422	216U	P240	5"	175	6
051144-01423	216U	P220	5"	175	6
NEW 051144-01424	216U	P180	5"	175	6
NEW 051144-01425	216U	P150	5"	175	6
NEW 051144-01426	216U	P120	5"	125	10
NEW 051144-01427	216U	P100	5"	125	10
NEW 051144-01428	216U	P80	5"	125	10
051131-01202	216U	P500	6"	75	6
051131-01203	216U	P400	6"	75	6
051131-01204	216U	P360	6"	75	6
051131-01205	216U	P320	6"	75	12
051131-01206	216U	P280	6"	75	6
051131-01207	216U	P240	6"	75	6
051131-01208	216U	P220	6"	75	12
051131-01217	216U	P800	6"	125	4
051131-01216	216U	P600	6"	125	4
051131-01432	216U	P500	6"	175	6
051131-01434	216U	P400	6"	175	6
051131-01433	216U	P360	6"	175	6
051144-01435	216U	P320	6"	175	6
051144-01436	216U	P280	6"	175	6
051144-01437	216U	P240	6"	175	6
051144-01438	216U	P220	6"	175	6
NEW 051144-01439	216U	P180	6"	175	6
NEW 051144-01440	216U	P150	6"	175	6
NEW 051144-01441	216U	P120	6"	125	10
NEW 051144-01442	216U	P100	6"	125	10
NEW 051144-01443	216U	P80	6"	125	10
051131-01483	216U	P500	8"	125	4
051131-01484	216U	P400	8"	125	4
051131-01485	216U	P320	8"	125	4
051131-01487	216U	P240	8"	125	4
051131-01488	216U	P220	8"	125	4
051131-01489	216U	P180	8"	125	4
051131-01490	216U	P150	8"	125	4
051131-01491	216U	P120	8"	125	4
051131-01492	216U	P100	8"	125	4
051131-01493	216U	P80	8"	125	4

Part Number	Product I.D.	Grade	Size	Discs Per Pack	Packs Per Case
<b>Packaged</b>					
051131-31434	216U	400A	6"	5	10
051131-31435	216U	320A	6"	5	10
051131-31438	216U	220A	6"	5	10
051131-31439	216U	180A	6"	5	10
051131-31440	216U	150A	6"	5	10
051131-31441	216U	120A	6"	5	10
051131-31442	216U	100A	6"	5	10
051131-31443	216U	80A	6"	5	10

## 3M™ Stikit™ Green Corps™ Production™ Fre-Cut™ Discs 246U

A durable and long-lasting disc product which has a pressure-sensitive backing for easy application. The discs come in roll form for easy dispensing with the 3M™ Stikit™ Disc Roll Dispenser (PN05450).



Part Number	Product I.D.	Grade	Size	Discs Per Roll/Pack	Rolls/Packs Per Case
051144-01501	246U	80D	5"	100, Bulk	10
051131-31501	246U	80D	5"	5	10
051144-01506	246U	80D	6"	100, Bulk	10
051131-31506	246U	80D	6"	5	10
051131-01549	246U	80D	8"	50, Bulk	5
051131-31549	246U	80D	8"	5	10

## 3M™ Green Corps™ Stikit™ Production™ Fre-Cut™ Discs 255U

Grade 24E was designed for heavy bottom paint and gelcoat removal, as well as for rough shaping of marine fairing compounds. Grade 60E was designed for paint removal and sanding marine fairing compounds and gelcoated fiberglass. The 3M™ Stikit™ Soft Disc Pad (PN05568) was designed to conform to the curves and contours found on boat hulls and decks.

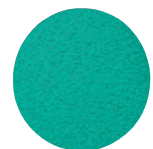

Part Number	Product I.D.	Grade	Size	Discs Per Box	Boxes Per Case
051131-01552	255U	24E	8"	20	5
051131-01556	255U	60E	8"	50	5

# 3M™ Stikit™ Sanding Discs

## 3M™ Green Corps™ Stikit™ Production™ Resin Bond Discs 251U

An all mineral/bond construction and tough "E" weight backing provides for a fast cutting, long lasting abrasive disc. Excellent for coarse sanding of hull and deck areas. Individually lined.



Part Number	Product			Discs Per Box/Pack	Boxes/Packs Per Case
	I.D.	Grade	Size		
051131-01545	251U	40E	5"	100, Bulk	5
051131-01546	251U	36E	5"	100, Bulk	5
051131-01547	251U	40E	6"	100, Bulk	5
051131-01548	251U	36E	6"	100, Bulk	5
051131-31547	251U	40E	6"	5	10
051131-31548	251U	36E	6"	5	10
051131-01550	251U	40E	8"	50, Bulk	5
051131-01551	251U	36E	8"	50, Bulk	5
051131-31550	251U	40E	8"	5	10
051131-31551	251U	36E	8"	5	10

## 3M™ Stikit™ Imperial™ Resin Bond Paper "F" Wt. Disc Rolls 363I

A tough and durable aluminum oxide mineral bonded with a full heat resistant resin to a strong "F" weight backing. The backing provides excellent shelling and tear resistance, thus increasing the life and performance of the disc. Excellent for scratch refinement after coarse sanding.



Part Number	Product			Discs Per Roll	Rolls Per Case
	I.D.	Grade	Size		
051144-21795	363I	180F	5"	100	4
051144-21796	363I	P150F	5"	100	4
051144-21797	363I	P120F	5"	100	4
051144-21798	363I	P100F	5"	100	4
051144-21799	363I	80F	5"	100	4
051144-21800	363I	60F	5"	100	4
051144-21789	363I	180F	6"	100	4
051144-21790	363I	P150F	6"	100	4
051144-21791	363I	P120F	6"	100	4
051144-21792	363I	P100F	6"	100	4
051144-21793	363I	80F	6"	100	4
051144-21794	363I	60F	6"	100	4
051144-21783	363I	180F	8"	50	4
051144-21784	363I	P150F	8"	50	4
051144-21785	363I	P120F	8"	50	4
051144-21786	363I	P100F	8"	50	4
051144-21787	363I	80F	8"	50	4
051144-21788	363I	60F	8"	50	4

## 3M™ Stikit™ Gold "C" Weight Disc Rolls 236U (Non-Staining Fre-Cut™)

A strong "C" weight backing provides excellent support for a tough and durable aluminum oxide mineral. These discs are aggressive, sharp, fast cutting and long lasting. The non-staining Fre-Cut™ resists loading and the pressure-sensitive adhesive ensures excellent adhesion to 3M™ Stikit™ pads. Excellent for gelcoat and plastic applications.



Part Number	Product			Discs Per Roll	Rolls Per Case
	I.D.	Grade	Size		
051144-86497	236U	P500	5"	100	4
051144-86496	236U	P400	5"	100	4
051144-86495	236U	P320	5"	100	4
051144-86494	236U	P240	5"	100	4
051144-86493	236U	P220	5"	100	4
051144-86492	236U	P180	5"	100	4
051144-86491	236U	P150	5"	100	4
051144-86490	236U	P120	5"	100	4
051144-86489	236U	P100	5"	100	4
051144-86488	236U	P80	5"	100	4
051144-86477	236U	P500	6"	100	4
051144-86476	236U	P400	6"	100	4
051144-86475	236U	P320	6"	100	4
051144-86474	236U	P240	6"	100	4
051144-86473	236U	P220	6"	100	4
051144-86472	236U	P180	6"	100	4
051144-86471	236U	P150	6"	100	4
051144-86470	236U	P120	6"	100	4
051144-86469	236U	P100	6"	100	4
051144-86468	236U	P80	6"	100	4

# 3M™ Stikit™ Sanding Discs

## 3M™ Stikit™ Tri-M-ite™ Fre-Cut™ Paper Disc Rolls 414N

An extremely sharp silicon carbide mineral surface with a special coating to resist loading. Has a pressure-sensitive adhesive backing for application to disc pad.



Part Number	Product I.D.	Grade	Size	Discs Per Roll	Rolls Per Case
051144-11287	414N	400A	5"	250	4
051144-01450	414N	320A	5"	250	4
051144-01451	414N	280A	5"	250	4
051144-01452	– Suggested Replacement PN01422 –				
051144-01453	– No Longer Available –				
051144-01454	414N	180A	5"	250	4
051144-01455	414N	150A	5"	250	4
051144-01456	414N	120A	5"	125	8
051144-01457	– Suggested Replacement PN01427 –				
051144-01458	– Suggested Replacement PN01428 –				
051144-11289	414N	400A	6"	250	4
051144-01465	414N	320A	6"	250	4
051144-01466	414N	280A	6"	250	4
051144-01467	414N	240A	6"	250	4
051144-01468	414N	220A	6"	250	4
051144-01469	414N	180A	6"	250	4
051144-01470	414N	150A	6"	250	4
051144-01471	414N	120A	6"	125	8
051144-01472	414N	100A	6"	125	8
051144-01473	414N	80A	6"	125	8

## 3M™ Stikit™ Production™ Fre-Cut™ Paper Disc Rolls 245N

A special coating makes these discs cut fast and last long. They also resist loading and cut "down time" on the job. The discs come in roll form for easy dispensing from our 3M™ Stikit™ Disc Roll Dispenser (PN05450). Discs have pressure-sensitive backing for quick application to disc pad.



Part Number	Product I.D.	Grade	Size	Discs Per Roll	Rolls Per Case
051144-01505	– Suggested Replacement PN01506 –				

Part Number	Product I.D.	Grade	Size	Discs Per Box	Boxes Per Case
051144-01540	245N	80D	8"	50	5

## 3M™ Stikit™ Production™ Paper Disc Rolls 240N

A special coating makes these discs cut fast and last long. They also resist loading and cut "down time" on the job. The discs come in roll form for easy dispensing from our 3M™ Stikit™ Disc Roll Dispenser (PN05450). Discs have pressure-sensitive backing for quick application to disc pad.



Part Number	Product I.D.	Grade	Size	Discs Per Box	Boxes Per Case
051144-01538	240N	40D	5"	100	5
051144-01539	240N	36D	5"	100	5
051144-01536	240N	40D	6"	100	5
051144-01537	240N	36D	6"	100	5
051144-01541	240N	40D	8"	50	5
051144-01542	240N	36D	8"	50	5

# 3M™ Three-M-ite™ and Wetordry™ Tri-M-ite™ Pressure-Sensitive Adhesive Sanding Discs

## 3M™ Three-M-ite™ Resin Bond Pressure-Sensitive Adhesive Discs 248D

Provides fast, efficient method for deburring, blending and cleaning up metal parts and surfaces of various sizes and shapes. Has a pressure-sensitive adhesive (PSA) backing which makes these discs easily applied or removed from face of rubber disc holder.



Part Number	Product I.D.	Grade	Size	Discs Per Pkg.	Discs Per Case
051144- <b>20874</b>	248D	36	8"	50	250
051144- <b>20865</b>	248D	80	9"	50	250
051144- <b>20866</b>	248D	60	9"	50	250
051111- <b>49540</b>	248D	120	10"	10	10
051111- <b>49539</b>	248D	100	10"	10	10
051144- <b>49688</b>	248D	80	10"	25	50
051144- <b>49689</b>	248D	60	10"	25	50
051111- <b>49538</b>	248D	50	10"	10	10
051111- <b>49537</b>	248D	40	10"	10	10
051111- <b>49536</b>	248D	36	10"	10	10
051144- <b>88901</b>	248D	100	12"	10	10
051144- <b>88902</b>	248D	80	12"	10	10
051144- <b>88903</b>	248D	60	12"	10	10
051144- <b>88904</b>	248D	50	12"	10	10
051144- <b>88905</b>	248D	40	12"	10	10
051144- <b>88906</b>	248D	36	12"	10	10

## 3M™ Wetordry™ Tri-M-ite™ Pressure-Sensitive Adhesive Paper Discs 438Q

These discs are a silicon carbide, closed coat product coated on "C" weight waterproof paper backing and bonded with a waterproof pressure-sensitive adhesive. Designed for machine applications where greater strength is required.



Part Number	Product I.D.	Grade	Size	Discs Per Pkg.	Discs Per Case
051144- <b>21923</b>	438Q	600C	8"	100	500
051144- <b>21364</b>	438Q	400C	8"	100	500
051144- <b>21365</b>	438Q	320C	8"	100	500
051144- <b>21366</b>	438Q	240C	8"	100	500
051144- <b>21367</b>	438Q	180C	8"	100	500

# 3M™ Stikit™ Sanding Disc Accessories

## 3M™ Stikit™ Disc Roll Dispensers

These sturdy metal dispensers provide a convenient means of storage and single disc dispensing of 3M™ Stikit™ Disc Rolls.

Dispenser can be wall or bench mounted as well as used portable. Part No. 05450 holds two 125 count disc rolls.

**NOTE: PRODUCTS DO NOT COME WITH THIS DISPENSER.**



Part Number	Description	Each Per Case
051144-05450	5" or 6" Diameter 1" Core	1
051144-45200	8" Diameter 3" Core	1
051144-45201	6" Diameter 3" Core	1

## 3M™ Stikit™ 75 Disc Roll Dispenser

A smaller, lighter version of Part No. 05450, designed for use with 75 count disc rolls. This handy "disc jockey" has all the same features as the larger model, dispensing two rolls of 3M™ Stikit™ 75 Disc Rolls simultaneously. **NOTE: PRODUCTS DO NOT COME WITH THIS DISPENSER.**



Part Number	Each Per Case
051131-05451	1

## 3M™ Stikit™ Disc Pads

Specially made for use with 3M™ Stikit™ Discs. The vinyl pad face provides good disc adhesion yet allows easy disc removal. Both pads are lightweight, shock resistant and well balanced. Maximum safe operating speed of 7000 RPM for both pads.



Part Number	For Use With Disc Size	Pads Per Case
051144-05575	5"	10
051144-05576	6"	10
<b>Peggable Package — 1 Pad Per Pack</b>		
051131-35575	5"	5
051131-35576	6"	5

## 3M™ Stikit™ Disc Pad 5" x 5/8" Hole

For use with 5" 3M™ Stikit™ discs on slow speed polishers and grinders up to 10,000 RPMs. (Thread size 5/8" - 11 female.)



Part Number	For Use With Disc Size	Face Color	Pads Per Case
051144-82189	5"	Red	10

## 3M™ Stikit™ Low Profile Disc Pads

3M™ Stikit™ Low Profile Disc Pads are designed to assist marine refinishers in sanding under rub rails, toe rails, along chines and rudder posts. The disc pad foam construction enhances the operators "feel" in final fairing and finishing applications utilizing 3M™ Stikit™ discs.



Part Number	For Use With Disc Size	Pads Per Case
051131-05555	5"	10
051131-05556	6"	10

## 3M™ Stikit™ Low Profile Finishing Disc Pad

3M™ Stikit™ Low Profile Finishing Disc Pads utilize a soft foam construction for fine finish sanding and offer outstanding conformability to contours and curves. Available in 5" and 6" diameter for use with 5" and 6" 3M™ Stikit™ Discs. Use on random orbital sanders only.



Part Number	For Use With Disc Size	Pads Per Case
051131-05545	5"	10
051131-05546	6"	10

## 3M™ Stikit™ Disc Pad

Specially designed for use with 3M™ Stikit™ Discs. Vinyl pad face provides good adhesion of the discs and allows easy removal. Edges are contoured to allow for sanding curves and close to moldings. Fits all standard (5/8" shaft) slow speed polishers. Maximum safe operating speed of 3000 RPM.



Part Number	For Use With Disc Size	Pads Per Case
051144-05579	8"	1

## 3M™ Stikit™ Soft Disc Pad

Specially designed for use with 3M™ Stikit™ Discs. Vinyl pad face provides good adhesion and allows easy removal of the discs. Its soft foam construction and tapered edge offer a high degree of conformability, providing a uniform finish when sanding contours and curves. Fits all standard (5/8" shaft) slow speed polishers. Maximum safe operating speed of 3000 RPM.



Part Number	For Use With Disc Size	Pads Per Case
051131-05568	8"	1

## 3M™ Stikit™ Disc Pad — 8" (Replacement Pads for Chicago Pneumatic Model 777 and National-Detroit Model 900 Sanders)

Specially designed for use with 3M™ Stikit™ discs. Vinyl pad face provides excellent adhesion and easy removal of the abrasive disc. Pad is lightweight, durable and well balanced. Maximum operating speed of 1500 RPM.

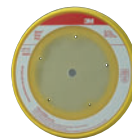

Part Number	Replacement Pad For Model	Pads Per Case
051131-05581	National-Detroit 900	1
051131-05582	Chicago Pneumatic 777	1

## 3M™ Stikit™ Hand Pads

3M™ Stikit™ Hand Pads are designed to be used with all grades of 3M™ Stikit™ Discs. These hand pads are firm yet conformable and are lightweight, making sanding of such areas as next to chrome and trim, corners and contours easier.



Part Number	For Use With Disc Size	Pads Per Case
051144-05585	5"	10
051144-05586	6"	10

## 3M™ Stikit™ Disc Hand Pad

The 3M™ Stikit™ Disc Hand Pad is a unique accessory for hand sanding. The 6" pad eliminates finger marks and has excellent conformability when used on contours. The pad is 1/4" thick.



Part Number	For Use With Disc Size	Pads Per Box	Boxes Per Case
051131-05591	6"	1	20
051144-45189	5"	1	20

# 3M™ Hookit™ II Sanding Discs

## 3M™ Imperial™ Hookit™ II Discs 334U and 734U

This product earns the 3M Purple color which indicates the latest 3M technology, greatest cost/value and highest quality available. 3M™ Imperial™ Hookit™ II Discs

334U and 734U are high-performance discs designed to cut faster and last longer enabling the user to obtain maximum usage from each disc. The 334U discs (grades P220-P500) are constructed of a high-performance aluminum oxide mineral, and the 734U discs (P80-P180) are constructed of a uniquely blended mineral. Both mineral systems are excellent for use on tough marine gelcoat, paint and primer systems.



Part Number	Product I.D.	Grade	Size	Discs Per Box	Boxes Per Case
051131-00656	334U	P500	5"	50	4
051131-00657	334U	P400	5"	50	4
051131-00658	334U	P360	5"	50	4
051131-00659	334U	P320	5"	50	4
051131-00660	334U	P280	5"	50	4
051131-00661	334U	P240	5"	50	4
051131-00662	334U	P220	5"	50	4
051131-00663	734U	P180	5"	50	4
051131-00664	734U	P150	5"	50	4
051131-00665	734U	P120	5"	50	4
051131-00666	734U	P100	5"	50	4
051131-00667	734U	P80	5"	50	4
051131-00672	334U	P500	6"	50	4
051131-00673	334U	P400	6"	50	4
051131-00674	334U	P360	6"	50	4
051131-00675	334U	P320	6"	50	4
051131-00676	334U	P280	6"	50	4
051131-00677	334U	P240	6"	50	4
051131-00678	334U	P220	6"	50	4
051131-00679	734U	P180	6"	50	4
051131-00680	734U	P150	6"	50	4
051131-00681	734U	P120	6"	50	4
051131-00682	734U	P100	6"	50	4
051131-00683	734U	P80	6"	50	4
051131-00684	334U	P320	8"	25	4
051131-00685	334U	P220	8"	25	4
051131-00686	734U	P180	8"	25	4
051131-00687	734U	P150	8"	25	4
051131-00688	734U	P120	8"	25	4
051131-00690	734U	P80	8"	25	4

## 3M™ Imperial™ Hookit™ II Discs 740I and 745I

This product earns the 3M Purple color which indicates the latest 3M technology, greatest cost/value and highest quality available. 3M™ Imperial™ Hookit™ II Discs

740I and 745I are constructed of a uniquely blended mineral bonded to a tough "E" weight backing. The Hookit™ II attachment system allows for easy application to and removal from the disc pad.



Part Number	Product I.D.	Grade	Size	Discs Per Box	Boxes Per Case
051131-00828	745I	P80E	5"	25	4
051131-00829	740I	40E	5"	25	4
051131-00830	740I	36E	5"	25	4
051131-00833	745I	P80E	6"	25	4
051131-00834	740I	40E	6"	25	4
051131-00835	740I	36E	6"	25	4
051131-00836	745I	P120E	8"	25	4
051131-00837	745I	P100E	8"	25	4
051131-00843	745I	P80E	8"	25	4
051131-00844	740I	40E	8"	25	4
051131-00845	740I	36E	8"	25	4

## 3M™ Hookit™ II Finishing Film Discs 260L

3M™ Hookit™ II Finishing Film Discs

260L are designed for use in scuff sanding before painting, as well as to remove runs, dust nibs and excess orange peel from paint and gelcoat prior to compounding. These discs are constructed of a high-performance aluminum oxide mineral strongly bonded to a smooth film backing. Cuts fast, lasts long, resists loading and leaves a consistent finish.



Part Number	Product I.D.	Grade	Size	Discs Per Box	Boxes Per Case
051131-00851	260L	P1500	5"	50	4
051131-00852	260L	P1200	5"	50	4
051131-00853	260L	P1000	5"	50	4
051131-00854	260L	P800	5"	50	4
051131-00855	260L	P600	5"	50	4
051131-00850	260L	P1500	6"	50	4
051131-00868	260L	P1200	6"	50	4
051131-00869	260L	P1000	6"	50	4
051131-00870	260L	P800	6"	50	4
051131-00871	260L	P600	6"	50	4



# 3M™ Hookit™ II Abrasive Accessories

## 3M™ Hookit™ II Disc Pad

This disc pad is specifically made to use with the Hookit™ II discs. The pad face securely holds the discs yet allows for easy change and reattachment of discs. The disc pad is lightweight, shock-resistant and well balanced. The tough, durable plastic hub and conformable foam body are designed for a maximum operating speed of 10000 RPM.



Part Number	For Use with Disc Size/Grade	Pads Per Case
051131-05275	5" (All Grades) Hard	10
051131-05276	6" (All Grades) Hard	10
051131-05286	6" (All Grades) Medium	10

## 3M™ Hookit™ II Low Profile Finishing Disc Pads

3M™ Hookit™ II Low Profile Finishing Disc Pads utilize a soft foam construction for fine finish sanding and offer outstanding conformability to contours and curves. Available in 5" and 6" diameter for use with 5" and 6" 3M™ Hookit™ II Discs. Use on random orbital sanders only.

Part Number	Pads Per Case
051131-05255	10

## 3M™ Hookit™ II Low Profile Finishing Disc Pad

3M™ Hookit™ II Low Profile Finishing Disc Pads utilize a soft foam construction for fine finish sanding and offer outstanding conformability to contours and curves. Available in 5" and 6" diameter for use with 5" and 6" 3M™ Hookit™ II Discs. Use on random orbital sanders only.



Part Number	For Use with Disc Size	Pads Per Case
051131-05245	5"	10
051131-05251	6"	10

## 3M™ Hookit™ II Soft Interface Pads

The 3M™ Hookit™ II Soft Interface Pad is constructed of a soft, durable foam. When used with a standard Hookit™ II backup pad, it increases conformability, allowing the technician to follow contours and get in closer to most edges.



Part Number	For Use with Disc Size	Pads Per Case
051131-05273	5" (600 and finer)	10
051131-05274	6" (600 and finer)	10

## 3M™ Hookit™ II Disc Pad

Designed especially for use with 3M™ Hookit™ II Discs. Vinyl pad face provides good adhesion of the discs and allows easy removal. Edges are contoured to allow for sanding curves and close to moldings. Fits all standard (5/8" shaft) slow-speed polishers with a maximum operating speed of 3000 RPM.



Part Number	For Use with Disc Size	Pads Per Case
051131-05279	8"	1

## 3M™ Hookit™ II Disc Pad for 8" Discs

(Replacement pads for Hutchins Eliminator, National-Detroit Model 900, Chicago Pneumatic Model 777, and Snap-On PS-200)



This disc pad is designed to be used with Hookit™ II discs. The Hookit™ II pad face provides excellent adhesion and easy removal of the abrasive disc. It is lightweight, durable and well balanced. Maximum operating speed of 1500 RPM.

Part Number	For Use on Model	Pads Per Case
051131-05281	National-Detroit 900	1
051131-05282	Chicago Pneumatic 777	1
051131-05283	Snap-On PS-200	1

## 3M™ Hookit™ II Soft Disc Pad

The 3M™ Hookit™ II Soft Disc Pad is designed especially for use with Hookit™ II discs. Hook-and-loop face secures the disc to the backup pad, yet provides for easy removal and attachment. Soft foam construction and tapered edge offer a high degree of conformability providing a uniform finish when sanding contours and curves.



Part Number	For Use with Disc Size	Pads Per Case
051131-05268	8"	1

## 3M™ Hookit™ II Hand Pad

A conformable pad with an elastic strap that holds the pad onto the hand for scuff sanding flat or contoured surfaces. The Hookit™ II pad face provides easy attachment and removal with Hookit™ II discs.



Part Number	Size	Pads Per Case
051131-05291	6"	20
051131-85088	5"	20

## 3M™ Hookit™ II Half Round Hand Pad

A conformable pad with a straight edge for scuff sanding up to detail lines and molding. Hookit™ II discs are applied by lining up with the curved side of the pad folded over the straight edge and attached on the other side.



Part Number	Pads Per Case
051131-05292	20

# 3M™ Hookit™ Sanding Discs

## 3M™ Imperial™ Hookit™ Disc Rolls 334U and 734U

This product earns the 3M Purple color which indicates the latest 3M technology, greatest cost/value and highest quality available. 3M™ Imperial™ Hookit™ Disc Rolls 334U and 734U are high-performance discs designed to cut faster and last longer enabling the user to obtain maximum usage from each disc. The 334U discs (grades P220-P500) are constructed of a high-performance aluminum oxide mineral, and the 734U discs (P80-P180) are constructed of a uniquely blended mineral. Both mineral systems are excellent for use on tough marine gelcoat, paint and primer systems.

	Part Number	Product I.D.	Grade	Size	Discs Per Box	Boxes Per Case
NEW	051131-01756	334U	P500	5"	50	4
NEW	051131-01757	334U	P400	5"	50	4
NEW	051131-01759	334U	P320	5"	50	4
NEW	051131-01760	334U	P280	5"	50	4
NEW	051131-01761	334U	P240	5"	50	4
NEW	051131-01762	334U	P220	5"	50	4
NEW	051131-01763	734U	P180	5"	50	4
NEW	051131-01764	734U	P150	5"	50	4
NEW	051131-01765	734U	P120	5"	50	4
NEW	051131-01766	734U	P100	5"	50	4
NEW	051131-01767	734U	P80	5"	50	4
NEW	051131-01771	334U	P500	6"	50	4
NEW	051131-01772	334U	P400	6"	50	4
NEW	051131-01774	334U	P320	6"	50	4
NEW	051131-01775	334U	P280	6"	50	4
NEW	051131-01776	334U	P240	6"	50	4
NEW	051131-01777	334U	P220	6"	50	4
NEW	051131-01778	734U	P180	6"	50	4
NEW	051131-01779	734U	P150	6"	50	4
NEW	051131-01780	734U	P120	6"	50	4
NEW	051131-01781	734U	P100	6"	50	4
NEW	051131-01782	734U	P80	6"	50	4

## 3M™ Imperial™ Hookit™ Discs 740I and 745I

This product earns the 3M Purple color which indicates the latest 3M technology, greatest cost/value and highest quality available. This uniquely blended mineral construction and tough "E" weight backing provides for a fast cutting, longer lasting abrasive. Excellent for stripping paint or sanding marine fairing compounds.

	Part Number	Product I.D.	Grade	Size	Discs Per Box	Boxes Per Case
NEW	051131-01743	745I	P80E	8"	25	4
NEW	051131-01768	740I	P60E	8"	25	4
NEW	051131-01744	740I	P40E	8"	25	4
NEW	051131-01745	740I	P36E	8"	25	4
NEW	051131-01728	745I	P80E	5"	25	4
NEW	051131-01770	740I	P60E	5"	25	4
NEW	051131-01729	740I	P40E	5"	25	4
NEW	051131-01730	740I	P36E	5"	25	4
NEW	051131-01733	745I	P80E	6"	25	4
NEW	051131-01773	740I	P60E	6"	25	4
NEW	051131-01734	740I	P40E	6"	25	4
NEW	051131-01735	740I	P36E	6"	25	4

## 3M™ Imperial™ Hookit™ Disc Rolls 360L

This product earns the 3M Purple color which indicates the latest 3M technology, greatest cost/value and highest quality available. 3M™ Imperial™ Hookit™ Disc Rolls 360L are high-performance discs designed to cut faster and last longer on composite substrates enabling the user to obtain maximum usage from each disc.

	Part Number	Product I.D.	Grade	Size	Discs Per Box	Boxes Per Case
NEW	051111-55722	360L	P800	5"	100	5
NEW	051111-55721	360L	P600	5"	100	5
NEW	051111-55720	360L	P500	5"	100	5
NEW	051111-55719	360L	P400	5"	100	5
NEW	051111-55718	360L	P360	5"	100	5
NEW	051111-55717	360L	P320	5"	100	5
NEW	051111-55716	360L	P280	5"	100	5
NEW	051111-55714	360L	P240	5"	100	5
NEW	051111-55713	360L	P220	5"	100	5
NEW	051135-13936	360L	P800	6"	100	5
NEW	051135-13937	360L	P600	6"	100	5
NEW	051135-13938	360L	P500	6"	100	5
NEW	051135-13939	360L	P400	6"	100	5
NEW	051135-13940	360L	P360	6"	100	5
NEW	051135-13941	360L	P320	6"	100	5
NEW	051135-13942	360L	P280	6"	100	5
NEW	051135-13943	360L	P240	6"	100	5
NEW	051135-13944	360L	P220	6"	100	5

Note: 6" available as a KUT item.

# 3M™ Hookit™ Sanding Discs

## 3M™ Hookit™ Gold Film Discs 255L

3M™ Hookit™ Gold Film Discs 255L incorporate a convenient hook-and-loop attachment system for easy attachment to and removal from the dual action pad face. The fast cutting, long lasting abrasive construction of the gold film product enables the user to obtain maximum usage of each disc.



Part Number	Product I.D.	Grade	Size	Discs Per Box	Boxes Per Case
051131-00912	255L	P500	3"	50	4
051131-00913	255L	P400	3"	50	4
051131-00914	255L	P320	3"	50	4
051131-00915	255L	P240	3"	50	4
051131-00916	255L	P220	3"	50	4
051131-00917	255L	P180	3"	50	4
051131-00918	255L	P150	3"	50	4
051131-00919	255L	P120	3"	50	4
051131-00920	255L	P100	3"	50	4
051131-00921	255L	P80	3"	50	4
051131-00998	255L	P600	5"	100	5
051131-00956	255L	P500	5"	100	4
051131-00957	255L	P400	5"	100	4
051131-00958	255L	P360	5"	100	4
051131-00959	255L	P320	5"	100	4
051131-00960	255L	P280	5"	100	4
051131-00961	255L	P240	5"	100	4
051131-00962	255L	P220	5"	100	4
051131-00963	255L	P180	5"	100	4
051131-00964	255L	P150	5"	100	4
051131-00965	255L	P120	5"	100	4
051131-00966	255L	P100	5"	100	4
051131-00967	255L	P80	5"	75	4
051131-00999	255L	P600	6"	100	5
051131-00972	255L	P500	6"	100	4
051131-00973	255L	P400	6"	100	4
051131-00974	255L	P360	6"	100	4
051131-00975	255L	P320	6"	100	4
051131-00976	255L	P280	6"	100	4
051131-00977	255L	P240	6"	100	4
051131-00978	255L	P220	6"	100	4
051131-00979	255L	P180	6"	100	4
051131-00980	255L	P150	6"	100	4
051131-00981	255L	P120	6"	100	4
051131-00982	255L	P100	6"	100	4
051131-00983	255L	P80	6"	75	4
051131-00984	255L	P320	8"	25	4
051131-00985	255L	P220	8"	25	4
051131-00986	255L	P180	8"	25	4
051131-00987	255L	P150	8"	25	4
051131-00988	255L	P120	8"	25	4
051131-00990	255L	P80	8"	25	4

## 3M™ Hookit™ Finishing Film Discs 260L

3M™ Hookit™ Finishing Film Discs 260L are designed for use in scuff sanding before painting, as well as to remove runs, dust nibs, and excess orange peel from paint and gelcoat prior to compounding. These discs allow for machine sanding versus having to hand sand prior to compounding or using very aggressive compounds (multiple applications of). These discs are constructed of a high-performance, aluminum oxide mineral bonding to a smooth film backing. Cuts fast, lasts long, resists loading and leaves a consistent finish.



Part Number	Product I.D.	Grade	Size	Discs Per Box	Boxes Per Case
051131-00907	260L	P1500	3"	50	4
051131-00908	260L	P1200	3"	50	4
051131-00909	260L	P1000	3"	50	4
051131-00910	260L	P800	3"	50	4
051131-00911	260L	P600	3"	50	4
051131-00951	260L	P1500	5"	100	4
051131-00952	260L	P1200	5"	100	4
051131-00953	260L	P1000	5"	100	4
051131-00954	260L	P800	5"	100	4
051131-00955	260L	P600	5"	100	4
051131-00950	260L	P1500	6"	100	4
051131-00968	260L	P1200	6"	100	4
051131-00969	260L	P1000	6"	100	4
051131-00970	260L	P800	6"	100	4
051131-00971	260L	P600	6"	100	4

## 3M™ Hookit™ Gold Discs 216U

These discs are aggressive sharp, fast cutting, and long lasting. Their construction also resists dulling, loading and edge wear. The pressure-sensitive adhesive coating ensures excellent adhesion to 3M™ Hookit™ disc pads without adhesive buildup.



Part Number	Product I.D.	Grade	Size	Discs Per Box	Boxes Per Case
051144-86299	216U	P600	5"	100	5
051144-86300	216U	P800	5"	100	5

# 3M™ Hookit™ Sanding Discs

## 3M™ Green Corps™ Hookit™ Regalite™ Discs 750U and 751U

A uniquely blended mineral bonded to a tough "E" weight backing provides a fast cutting, long lasting abrasive. The 3M™ Hookit™ attachment system allows easy application to and removal from the disc pad. Excellent for stripping paint or sanding marine fairing compounds.



Part Number	Product I.D.	Grade	Size	Discs Per Box	Boxes Per Case
051131-00506	750U	100E	5"	25	5
051131-00507	750U	80E	5"	25	5
051131-00508	750U	60E	5"	25	5
051131-00509	751U	40E	5"	25	5
051131-00510	751U	36E	5"	25	5
051131-00511	750U	100E	6"	25	5
051131-00512	750U	80E	6"	25	5
051131-00513	750U	60E	6"	25	5
051131-00515	751U	40E	6"	25	5
051131-00516	751U	36E	6"	25	5
051131-00520	750U	100E	8"	25	5
051131-00521	750U	80E	8"	25	5
051131-00522	750U	60E	8"	25	5
051131-00524	751U	40E	8"	25	5
051131-00525	751U	36E	8"	25	5

## 3M™ Green Corps™ Hookit™ Production™ Fre-Cut™ Discs 255U

They attach as quickly as they cut and they can be re-attached and used until their full life is realized. Grade 24E was designed for heavy bottom paint and gelcoat removal, as well as for rough shaping of marine fairing compounds. Grade 60E was designed for paint removal and sanding marine fairing compounds and gelcoated fiberglass. The 3M™ Hookit™ Soft Disc Pad (PN05768) was designed to conform to the curves and contours found on boat hulls and decks.



Part Number	Product I.D.	Grade	Size	Discs Per Box	Boxes Per Case
051131-01652	255U	24E	8"	20	5
051131-01656	255U	60E	8"	25	5

# 3M™ Hookit™ Sanding Disc Accessories

## 3M™ Hookit™ Disc Pad

This pad is specifically made to use with the 3M™ Hookit™ discs. The pad face securely holds the discs yet allows for easy change and reattachment of discs. The pad is lightweight, shock resistant and well-balanced. The tough durable plastic hub and a conformable foam body are designed for a maximum operating speed of 7000 RPM.



Part Number	For Use With Disc Size	Pads Per Case
051131-05775	5"	10
051131-05776	6"	10
<b>Peggable Package — 1 Pad Per Pack</b>		
051131-35776	6"	5

## 3M™ Hookit™ Low Profile Finishing Disc Pads

3M™ Hookit™ Low Profile Finishing Disc Pads utilize a soft foam construction for fine finish sanding and offer outstanding conformability to contours and curves. Available in 5" and 6" diameter for use with 5" and 6" 3M™ Hookit™ Discs. Use on random orbital sanders only.



Part Number	For Use With Disc Size	Pads Per Case
051131-05755	5"	10
051131-05756	6"	10

## 3M™ Hookit™ Low Profile Finishing Disc Pad for 3", 5" and 6" Discs

3M™ Hookit™ Low Profile Finishing Disc Pads utilize a soft foam construction for fine finish sanding and offer outstanding conformability to contours and curves. Available in 5" and 6" diameter for use with 5" and 6" 3M™ Hookit™ Discs. Use on random orbital sanders only.



Part Number	For Use With Disc Size	Pads Per Case
051144-77855	5"	10
051131-05747	6"	10
051131-05769*	3"	5

\* For use on Snap-On AT-402 Sander

## 3M™ Hookit™ Soft Interface Pads

These soft interface pads are a very flexible foam which attach to a standard 3M™ Hookit™ disc pad to provide excellent full disc contact, even on curved surfaces.



Part Number	For Use With Disc Size	Pads Per Case
051131-05773	5"	10
051131-05774	6"	10

## 3M™ Hookit™ Disc Pad

Designed especially for use with 3M™ Hookit™ Regalite™ Discs, the hook-and-loop face secures the disc to the backup pad, yet provides for easy removal and reattachment. Edges are contoured to allow for sanding curves and close to moldings. Fits all standard (5/8" shaft) slow-speed polishers with a maximum operating speed of 3000 RPM.



Part Number	For Use With Disc Size	Pads Per Case
051131-05779	8"	1

## 3M™ Hookit™ Soft Disc Pad

The 3M™ Hookit™ Soft Disc Pad is designed especially for use with 3M™ Hookit™ discs. The hook-and-loop face secures the disc to the backup pad, yet provides for easy removal and attachment. Soft foam construction and tapered edge offer a high degree of conformability providing a uniform finish when sanding contours and curves. Fits all standard (5/8" shaft) slow-speed polishers. Maximum safe operating speed of 3000 RPM.



Part Number	For Use With Disc Size	Pads Per Case
051131-05768	8"	1

## 3M™ Hookit™ Disc Pad For 8" Discs

(Replacement pads for National-Detroit Model 900 and Chicago Pneumatic Model 777, and Snap-On PS200)



Specially designed to be used with 3M™ Hookit™ Regalite™ Discs. 3M™ Hookit™ pad face provides excellent adhesion and easy removal of the abrasive disc. Pad is lightweight, durable and well-balanced. Maximum operating speed of 1500 RPM.

Part Number	Replacement Pad For Model	Pads Per Case
051131-05781	National-Detroit 900	1
051131-05782	Chicago Pneumatic 777	1

## 3M™ Hookit™ Hand Pad

This is a conformable pad with an elastic strap that holds the pad onto the hand for scuff sanding flat or contoured surfaces. The 3M™ Hookit™ pad face provides easy attachment and removal with 3M™ Hookit™ discs.



Part Number	For Use With Disc Size	Pads Per Case
051144-77752	5"	20
051131-05791	6"	20

## 3M™ Hookit™ Half Round Pad

This is a conformable pad with a straight edge for scuff sanding up to detail lines and molding. 3M™ Hookit™ discs are applied by lining up with the curved side of the pad folded over the straight edge and attached on the other side. The 3M™ Hookit™ pad face provides easy attachment and removal with 3M™ Hookit™ discs.



Part Number	For Use With Disc Size	Pads Per Case
051131-05792	6"	20

# Glue-On Sanding Discs

## 3M™ Gold Film Discs 255L

3M™ Gold Film Discs 255L are designed for high performance use on tougher-to-sand marine paint, gelcoat and primer systems. Feathering disc adhesive is required to adhere these high performance aluminum oxide mineral, film backed discs. Cuts fast, lasts long, and leaves a consistent finish.



Part Number	Product I.D.	Grade	Size	Discs Per Box	Boxes Per Case
051144- <b>84754</b>	255L	P600	5"	100	500
051144- <b>83411</b>	255L	P400	5"	100	500
051144- <b>83417</b>	255L	P180	5"	100	500
051144- <b>83421</b>	255L	P80	5"	100	500

## 3M™ Production™ Fre-Cut™ Gold Paper Discs 216U and 236U

Dry sanding only. 3M™ Production™ Fre-Cut™ Gold Paper Discs 216U and 236U have a sharp mineral to cut through tough surfaces fast. This construction resists dulling, loading and edge wear. Discs are available in "A" weight in a full range of grits.



Part Number	Product I.D.	Grade	Size	Discs Per Box	Boxes Per Case
051131- <b>01019</b>	216U	400A	5"	100	10
051131- <b>01020</b>	216U	320A	5"	100	10
051131- <b>01022</b>	216U	240A	5"	100	10
051131- <b>01023</b>	216U	220A	5"	100	10
051131- <b>01024</b>	236U	180C	5"	100	10
051131- <b>01025</b>	236U	150C	5"	100	10
051131- <b>01026</b>	236U	120C	5"	100	10
051131- <b>01027</b>	236U	100C	5"	100	10
051131- <b>01028</b>	236U	80C	5"	100	10
051131- <b>01034</b>	216U	400A	6"	100	10
051131- <b>01035</b>	216U	320A	6"	100	10
051131- <b>01037</b>	216U	240A	6"	100	10
051131- <b>01038</b>	216U	220A	6"	100	10
051131- <b>01039</b>	236U	180C	6"	100	10
051131- <b>01040</b>	236U	150C	6"	100	10
051131- <b>01041</b>	236U	120C	6"	100	10
051131- <b>01042</b>	236U	100C	6"	100	10
051131- <b>01043</b>	236U	80C	6"	100	10

## 3M™ Green Corps™ Production™ Fre-Cut™ Paper Discs 246U

3M™ Green Corps™ Production™ Fre-Cut™ Paper Discs 246U are a durable and long-lasting disc product. A tough mineral/bond construction and a special treatment to resist loading provides a long-lasting, fast-cutting paper disc.



Part Number	Product I.D.	Grade	Size	Discs Per Box	Boxes Per Case
051131- <b>01502</b>	246U	80D	5"	100	10
051131- <b>01507</b>	– No Longer Available –				
051131- <b>01649</b>	246U	80D	8"	50	5

## 3M™ Green Corps™ Production™ Paper Discs 252U

3M™ Green Corps™ Production™ Paper Discs 252U have a unique mineral/ bond construction and tough "E" weight backing that provides a fast-cutting, long-lasting abrasive disc.



Part Number	Product I.D.	Grade	Size	Discs Per Box	Boxes Per Case
051131- <b>01645</b>	252U	40E	5"	100	5
051131- <b>01647</b>	252U	40E	6"	100	5
051131- <b>01648</b>	252U	36E	6"	100	5
051131- <b>01651</b>	252U	36E	8"	50	5

# Glue-On Sanding Discs

## 3M™ Production™ Paper Discs 230N, 240N and 346U (Open Coat)

Dry sanding only. Used on various disc machines for fairing and finishing, for light paint removal and featheredging. Resists loading.



Part Number	Product I.D.	Grade	Size	Discs Per Box	Boxes Per Case
051144-01123	– Suggested Replacement PN01028 –				
051144-01124	240N	60D	5"	100	5
051144-01126	– No Longer Available –				
051144-01129	346U	36D	5"	100	5
051144-01133	240N	80D	6"	100	5
051144-01136	– Suggested Replacement PN01647 –				
051144-01139	– Superseded by PN01648 –				
051144-01143	240N	80D	8"	100	5
051144-01146	346U	40D	8"	100	5
051144-01149	– Suggested Replacement PN01651 –				

## 3M™ Tri-M-ite™ Fre-Cut™ Paper Discs 414N

Dry sanding only on various disc machines. Has special treatment for minimum loading. Used for sanding old finishes, fine featheredging and sanding primer surfaces.



Part Number	Product I.D.	Grade	Size	Discs Per Box	Boxes Per Case
051144-01099	414N	400A	5"	250	4
051144-01100	– Suggested Replacement PN01020 –				
051144-01102	– Suggested Replacement PN01022 –				
051144-01103	414N	220A	5"	250	4
051144-01104	– Suggested Replacement PN01024 –				
051144-01105	414N	150A	5"	250	4
051144-01106	414N	120A	5"	250	4
051144-01107	– Superseded by PN01027 –				
051144-01108	– Suggested Replacement PN01028 –				
051144-01109	– Suggested Replacement PN01035 –				
051144-01110	414N	280A	6"	250	4
051144-01111	414N	240A	6"	250	4
051144-01112	414N	220A	6"	250	4
051144-01113	– Superseded by PN01039 –				
051144-01114	414N	150A	6"	250	4

# Glue-On Sanding Disc Accessories

## 3M™ Disc Pads

Designed for use with all dual-action random disc sanders. The specially designed cloth face provides an excellent surface for bonding paper discs with 3M™ Feathering Disc Adhesive (PN08051). Pads are lightweight, durable and well balanced. Edges are contoured to allow for sanding curves and close to moldings. Made with tough durable hub and a conformable foam body. Maximum safe operating speed of 7000 RPM for both pads.

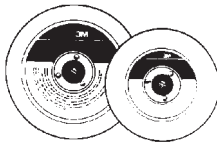

Part Number	For Use With Disc Size	Pads Per Case
051144-05577	5" Diameter	10
051144-05578	6" Diameter	10

## 3M™ Disc Pad for 8" Discs

The specially designed cloth face provides an excellent surface for bonding paper discs with 3M™ Feathering Disc Adhesive (PN08051). Edges are contoured to allow for sanding curves and close to moldings. The lightweight molded foam body with a tough outer skin and metal thread insert provides for longer pad life. Fits all standard (5/8" shaft) slow-speed polishers. Maximum safe operating speed of 3000 RPM.



Part Number	For Use With Disc Size	Pads Per Case
051144-05580	8" Diameter	1

## 3M™ Spray Disc Adhesive

A transparent, instant tack adhesive for bonding feathering discs. Can use many discs per adhesive application without adhesive buildup. Discs remove easily and cleanly.

Part Number	Container Size	Containers Per Case
051135-08054	8 oz. Aerosol	6

# Abrasive 2-3/4" Sheet and Sheet Roll Availability Grid

NOTE: WOD™ = Wetordry™ Resin Bond = RB

Size and Grade	3M™ Imperial™ Stikit™ Sheets 740I & 745I	3M™ Stikit™ Gold Sheet Rolls 216U	3M™ Green Corps™ Stikit™ Production™ RB Paper Sheets 246U & 251U	3M™ Imperial™ Hookit™ II Film Sheets 334U & 734U	3M™ Imperial™ Hookit™ II Sheets 740I & 745I	3M™ Hookit™ Faring Board Sheets	3M™ Green Corps™ Hookit™ Regalite™ Sheets 750U & 751U	3M™ Hookit™ Gold Film Sheets 255L	3M™ Imperial™ Dry Sheets 740I & 745I	3M™ Production™ Resinite™ Fre-Cut™ Gold Paper Sheets 216U	3M™ Green Corps™ Production™ RB Paper Sheets 246U & 252U
2-3/4" x 220				02669				02469			
16" 180				02670				02470			
150				02672				02472			
120	00389			02673	00799			02473	02254		
2-3/4" x 100	00390		02230*		00800		00538		02255		
16-1/2" 80	00391		02231		00801		00539		02256		
60	00393		02232				00540				
40	00394				00802		00542		02258		
36					00803		00543		02259		
2-3/4" x 320											
17-1/2" 240										02566	
220										02567	
180										02568	
150										02569	
120											
80											02220*
40											02221
36											02222
2-3/4" x 80		02599									
25 yds.											
2-3/4" x 120		02597									
30 yds.	100	02598									
2-3/4" x 500		02589									
45 yds.	400	02590									
320		02591									
240		02593									
220		02594									
180		02595									
150		02596									

\* 3M™ Fre-Cut™ Sheet



## Abrasive 4-1/2" Sheet and Sheet Roll Availability Grid

NOTE: WOD™ = Wetordry™ Resin Bond = RB

Size and Grade	3M™ Imperial™ Stikit™ Sheets 740I & 745I	3M™ Stikit™ Gold Sheet Rolls 216U	3M™ Green Corps™ Stikit™ Production™ RB Paper Sheets 246U & 251U	3M™ Imperial™ Hookit™ II Film Sheets 365L & 765L	3M™ Imperial™ Hookit™ II Sheets 740I & 745I	3M™ Hookit™ Fairing Board Sheets	3M™ Green Corps™ Hookit™ Regalite™ Sheets 750U & 751U	3M™ Hookit™ Gold Film Sheets 255L	3M™ Imperial™ Dry Sheets 740I & 745I	3M™ Production™ Resinite™ Fre-Cut™ Gold Paper Sheets 216U	3M™ Green Corps™ Production™ RB Paper Sheets 246U & 252U
4-1/2" 500						02628*					
400						02629*					
320						02630*					
220						02631*					
180						02632*					
150						02633*					
120						02634*					
100						02637*					
80						02638*					
60						02639*					
40						02640*					
36						02641*					
24											
4-1/2" 120		02696**									
100		02697**									
80		02698**									
4-1/2" 400		02689**									
320		02691**									
220		02693**									
180		02694**									
150		02695**									

\* Cut Sheets 30"

\*\* Rolls

## Abrasive 9" x 11" Sheet Availability Grid

Size and Grade	3M™ Imperial™ Wetordry™ Paper Sheets 213Q & 401Q	Wetordry™ Tri-M-ite™ Paper Sheets 411Q, 413Q & 431Q	3M™ Production™ Paper 210N, 336I, 346I & 346U	3M™ Production™ Resinite™ Fre-Cut™ Gold Paper Sheets 216U
9" x 11" Fine				
Medium				
Coarse				
Crocus				
2500	02019			
2000	02020			
1500	02032			
1200	02033			
1000	02034			
800	02035			02536
600	02036	02000		02537
500	02037	02001		02538
400	02038	02002		02539
360	02039	02003		02540
320	02040	02004		02541
280	02041	02005		02542
240	02042	02006		02543
220	02043	02007	02103	02544
180		02014	02104	02545
150		02015	02112	02546
120		02016	02106 & 02113	02547
100		02017	02107 & 02114	02548
80		02018	02108 & 02115	02549
60		02019	02116	
50			02117	
40			02118	
36			02119	

# 3M™ Stikit™ Abrasive Sheets and Sheet Rolls

## 3M™ Imperial™ Stikit™ Sheets 740I and 745I

This product earns the 3M Purple color which indicates the latest 3M technology, greatest cost/value and highest quality available. This uniquely blended mineral construction and tough "E" weight backing provides for a fast cutting, longer lasting abrasive. Excellent for stripping paint or sanding marine fairing compounds.



Part Number	Product		Size	Sheets Per Box	Boxes Per Case
	I.D.	Grade			
051131-00389	745I	P120E	2-3/4" x 16-1/2"	50	4
051131-00390	745I	P100E	2-3/4" x 16-1/2"	50	4
051131-00391	745I	P80E	2-3/4" x 16-1/2"	50	4
051131-00392	740I	60E	2-3/4" x 16-1/2"	50	4
051131-00393	740I	40E	2-3/4" x 16-1/2"	50	4
051131-00394	740I	36E	2-3/4" x 16-1/2"	50	4

## 3M™ Stikit™ Gold Sheet Rolls 216U, 2-3/4" Width

3M™ Stikit™ Gold Sheet Rolls 216U are coated aluminum oxide abrasive rolls bonded with resin and a pressure-sensitive adhesive backing for quick adhesion to and easy removal from 3M™ Stikit™ Blocks. Use with the 3M™ Stikit™ Double Roll Dispenser (PN05452), to cut desired length for use on file shoes and sanding blocks.



Part Number	Product		Width	Length	Rolls Per Case
	I.D.	Grade			
051131-02589	216U	P500	2-3/4"	45 yds.	10
051131-02590	216U	P400	2-3/4"	45 yds.	10
051131-02591	216U	P320	2-3/4"	45 yds.	10
051131-02593	216U	P240	2-3/4"	45 yds.	10
051131-02594	216U	P220	2-3/4"	45 yds.	10
051131-02595	216U	P180	2-3/4"	45 yds.	10
051131-02596	216U	P150	2-3/4"	45 yds.	10
051131-02597	216U	P120	2-3/4"	30 yds.	10
051131-02598	216U	P100	2-3/4"	30 yds.	10
051131-02599	216U	P80	2-3/4"	25 yds.	10

## 3M™ Stikit™ Gold Sheet Rolls 216U, 4-1/2" Width

3M™ Stikit™ Gold Sheet Rolls 216U are coated aluminum oxide abrasive rolls bonded with resin and backed with a pressure-sensitive adhesive backing for quick adhesion to and easy removal from 3M™ Stikit™ Finish Sander Conversion Pads (PN00402). Cut to desired length for use on vibrator sanders, fairing boards and sanding blocks.



Part Number	Product		Width	Length	Rolls Per Case
	I.D.	Grade			
051131-02689	216U	P400	4-1/2"	25 yds.	6
051131-02691	216U	P320	4-1/2"	25 yds.	6
051131-02693	216U	P220	4-1/2"	25 yds.	6
051131-02694	216U	P180	4-1/2"	25 yds.	6
051131-02695	216U	P150	4-1/2"	25 yds.	6
051131-02696	216U	P120	4-1/2"	20 yds.	6
051131-02697	216U	P100	4-1/2"	20 yds.	6
051131-02698	216U	P80	4-1/2"	20 yds.	6

## 3M™ Green Corps™ Stikit™ Production™ Resin Bond Paper Sheets 246U and 251U, 2-3/4" Width

Sheets have pressure-sensitive adhesive backing for easy application to and removal from tool face. Special mineral coating plus improved mineral bond provides for fast cutting abrasive life. Individually lined. Grade 80D has 3M™ Fre-Cut™ coating.



Part Number	Product		Size	Sheets Per Box	Boxes Per Case
	I.D.	Grade			
051131-02230	246U	80D	2-3/4" x 16-1/2"	100	5
051144-02231	251U	40E	2-3/4" x 16-1/2"	100	5
051144-02232	251U	36E	2-3/4" x 16-1/2"	100	5

Part Number	Product		Size	Sheets Per Pack	Packs Per Case
	I.D.	Grade			
051131-32230	246U	80D	2-3/4" x 16-1/2"	5	10
051131-32231	251U	40E	2-3/4" x 16-1/2"	5	10
051131-32232	251U	36E	2-3/4" x 16-1/2"	5	10

## 3M™ Stikit™ Production™ Paper Sheets 245N and 240N, 2-3/4" Width

Sheets have pressure-sensitive adhesive backing for easy application to and removal from tool face. Size provides material for folding over ends to work in small areas. Sheets are specially treated to prevent loading and have a durable backing. Individually lined.



Part Number	Product		Size	Sheets Per Box	Boxes Per Case
	I.D.	Grade			
051144-02241	245N	80D	2-3/4" x 16-1/2"	100	5
051144-02248	240N	40D	2-3/4" x 16-1/2"	100	5
051144-02249	240N	36D	2-3/4" x 16-1/2"	100	5

## 3M™ Stikit™ Tri-M-ite™ Fre-Cut™ Paper Sheet Rolls 415N and 415U, 2-3/4" Width

These coated abrasive rolls have a pressure-sensitive adhesive backing for quick adhesion to and easy removal from 3M™ Stikit™ Accessories. 3M™ Fre-Cut™ coating increases sheet life and reduces loading, when working on wood, plastic and fiberglass. Excellent for intermediate and fine sanding, fairing and scuffing of boat hulls.



Part Number	Product		Width	Length	Rolls Per Case
	I.D.	Grade			
051144-02556	415N	320A	2-3/4"	50 yds.	10
051144-02559	415U	220A	2-3/4"	50 yds.	10
051144-02560	415U	180A	2-3/4"	50 yds.	10
051144-02561	415U	150A	2-3/4"	50 yds.	10
051144-02562	415U	120A	2-3/4"	35 yds.	10
051144-02563	415U	100A	2-3/4"	35 yds.	10
051131-02565	415U	80A	2-3/4"	25 yds.	10

# 3M™ Stikit™ Abrasive Sheet and Sheet Roll Accessories

## 3M™ Stikit™ Hand Blocks

3M™ Stikit™ Hand Blocks are made of a sturdy, durable, high-strength material and are shaped to fit the hand comfortably. These blocks have an embossed rubber face which allows good adhesion for 3M™ Stikit™ Sheet Rolls.



Part Number	Size	Blocks Per Case
051144-05440	2-3/4" x 5"	10
051144-05441	2-3/4" x 7-3/4"	10

## 3M™ Stikit™ Soft Hand Block

Made of a tough flexible foam which allows the user to block sand on flat surface or in contours. 3M™ Stikit™ sheets adhere firmly to its vinyl face and won't slip or tear.

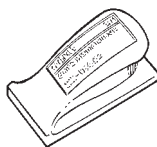

Part Number	Size	Blocks Per Case
051144-05442	2-3/4" x 5"	10

## 3M™ Stikit™ Soft Hand Pad, 2-3/4" Width

For use with 3M™ Stikit™ Sheet Rolls. Provides a soft, controlled touch. Eliminates finger marks and edge cutting into primer and paint.



Part Number	Pads Per Box	Boxes Per Case
051144-05530	5	10

## 3M™ Stikit™ Hand File Board

The 3M™ Stikit™ Hand File Board is a well-balanced, durable tool that is resistant to most solvents, has a sturdy design that provides a non-twisting, flat sanding surface. This file board has an embossed rubber face that allows adhesion release when used with 3M™ 2-3/4" x 16-1/2" sheets. Can be cleaned with lacquer thinner.



Part Number	Abrasive Size	Boards Per Case
051144-05444	2-3/4" x 16-1/2"	1

## 3M™ Stikit™ Orbital Air File Shoe

Designed for use on Hutchins, Rodac and Chicago Pneumatic Orbital Air Files and for use with 3M™ Stikit™ File Sheets, 2-3/4" x 16-1/2". This shoe features a tuck-in clip on the front edge for easy insertion and quick application of self-adhering 3M™ Stikit™ Sheets to the pad face.



Part Number	Abrasive Size	Shoes Per Case
051144-05446	- No Longer Available -	

## 3M™ Stikit™ Air File Shoe

The 3M™ Stikit™ Air File Shoe has been specifically designed for use on all straight line air files and for use with our 3M™ Stikit™ File Sheets, 2-3/4" x 16-1/2". This air file shoe features a tuck-in clip on the leading edge for easy insertion and quick application of the file sheets plus the elimination of mechanical clips to make sheet removal easier.



Part Number	Abrasive Size	Shoes/Packs Per Case
051144-05448	2-3/4" x 16-1/2"	10

Part Number	Each Per Pack	Packs Per Case
<b>Peggable Package</b>		

051131-35448	- No Longer Available -
--------------	-------------------------

## 3M™ Stikit™ Double Roll Dispenser for 2-3/4" Width Rolls

A portable, sturdy dispenser which holds two 2-3/4" width 3M™ Stikit™ Sheet Rolls for quick and easy dispensing. **NOTE: PRODUCTS DO NOT COME WITH THE DISPENSER.**



Part Number	Dispensers Per Case
051144-05452	1

## 3M™ Stikit™ Finish Sander Conversion Pads

These pads convert finish sander (i.e., palm sander, vibrator sander) pads to accept 4-1/2" 3M™ Stikit™ sheet roll abrasives. The vinyl face allows for an easier removal of the abrasive and a longer lasting pad is the result. Converts Porter Cable tools.



Part Number	Description	Pads Per Case
051115-00402	- No Longer Available -	

# 3M™ Imperial™ Hookit™ II Abrasive Sheets and Accessories

## 3M™ Imperial™ Hookit™ II Sheets 334U and 734U

This product earns the 3M Purple color which indicates the latest 3M technology, greatest cost/value and highest quality available. 3M™ Imperial™ Hookit™ II Sheets 334U and 734U are high-performance discs designed to cut faster and last longer enabling the user to obtain maximum usage from each disc. The 334U discs (grades P220-P500) are constructed of a high-performance aluminum oxide mineral, and the 734U discs (P80-P180) are constructed of a uniquely blended mineral. Both mineral systems are excellent for use on tough marine gelcoat, paint and primer systems.



Part Number	Product		Size	Sheets Per Box	Boxes Per Case
	I.D.	Grade			
051131-02669	334U	P220	2-3/4" x 16"	25	4
051131-02670	734U	P180	2-3/4" x 16"	25	4
051131-02672	734U	P150	2-3/4" x 16"	25	4
051131-02673	734U	P120	2-3/4" x 16"	25	4

## 3M™ Imperial™ Hookit™ II Sheets 740I and 745I

3M™ Imperial™ Hookit™ II Sheets 740I and 745I earn the 3M Purple color because these high-performance abrasives are designed to cut fast and last long, enabling the user to obtain maximum usage from each sheet. Constructed of a uniquely blended mineral bonded to a tough "E" weight backing, the Hookit™ II attachment system allows for easy application and removal.



Part Number	Product		Size	Sheets Per Box	Boxes Per Case
	I.D.	Grade			
051131-00799	745I	P120E	2-3/4" x 16-1/2"	25	4
051131-00800	745I	P100E	2-3/4" x 16-1/2"	25	4
051131-00801	745I	P80E	2-3/4" x 16-1/2"	25	4
051131-00802	740I	40E	2-3/4" x 16-1/2"	25	4
051131-00803	740I	36E	2-3/4" x 16-1/2"	25	4

## 3M™ Hookit™ II Hand Block

The 3M™ Hookit™ II Hand Block is made of a sturdy, durable high-strength material to fit the hand comfortably. The embossed Hookit™ II face allows easy attachment and removal of Hookit™ II file sheets. PN05240 is designed to use one-third of a Hookit™ II sheet while PN05241 uses one-half of a Hookit™ II sheet.



Part Number	Size	Blocks Per Case
051131-05240	2-3/4" x 5"	10
051131-05241	2-3/4" x 7-3/4"	10

## 3M™ Hookit™ II Soft Hand Block

The 3M™ Hookit™ II Soft Hand Block is made of a tough, flexible foam for block sanding flat and contoured areas. The Hookit™ II face provides positive attachment of Hookit™ II sheets. Allows easy change and reattachment.



Part Number	Size	Blocks Per Case
051131-05242	2-3/4" x 5"	10

## 3M™ Hookit™ II Hand File Board

The 3M™ Hookit™ II Hand File Board is a well balanced, durable shop tool resistant to most solvents. Its sturdy design provides a non-twisting flat sanding surface. The embossed Hookit™ II face allows easy attachment and removal of Hookit™ II file sheets.



Part Number	Size	Boards Per Case
051131-05244	2-3/4" x 16-1/2"	1

## 3M™ Hookit™ II Orbital Air File Shoe

The 3M™ Hookit™ II Orbital Air File Shoe is designed for use on Hutchins, Rodac, and Chicago Pneumatic Orbital air files. The embossed Hookit™ II face allows easy attachment and removal of Hookit™ II file sheets, while eliminating the need for mechanical clips.



Part Number	Size	Shoes Per Case
051131-05246	3-3/4" x 16-1/2"	5

## 3M™ Hookit™ II Air File Shoe

The 3M™ Hookit™ II Air File Shoe is specially designed for use on all straight air files with Hookit™ II file sheets. It features a tuck-in clip for easy insertion and application of Hookit™ II sheets to the pad face.



Part Number	Size	Shoes Per Case
051131-05248	2-3/4" x 16-1/2"	5

# 3M™ Hookit™ Fairing Board System

## 3M™ Marine Hookit™ Fairing Boards — Rigid and Flexible

The 3M™ Marine Hookit™ Fairing Boards are designed for fairing, shaping, sanding and finishing boats, plugs and molds.

These boards feature a durable, lightweight construction that combines worker comfort and getting desired results quickly. The rigid fairing board can be used for large flat areas such as freeboard and deck areas. The flexible fairing board is for concave and convex curved areas such as hulls. These boards utilize 4-1/2" x 30" 3M™ Hookit™ abrasive sheets.

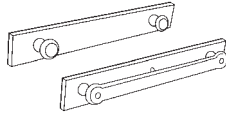

Part Number	Type	Abrasive Size	Boards Per Case
051144- <b>83497</b>	Rigid	4-1/2" x 30"	1
051144- <b>83978</b>	Flexible	4-1/2" x 30"	1

## 3M™ Hookit™ Gold Film 4-1/2" x 30" Fairing Board Sheets 255L

These sheets utilize the convenient hook-and-loop attachment system for easy placement on and removal from the tool face. Designed for dry sanding using a 3M™ Marine Hookit™ Fairing Board (PNs 83497 or 83978).

Part Number	Product		Size	Sheets Per Sleeve	Sleeves Per Case
	I.D.	Grade			
051131- <b>02630</b>	255L	P320	4-1/2" x 30"	10	5
051131- <b>02631</b>	255L	P220	4-1/2" x 30"	10	5
051131- <b>02632</b>	255L	P180	4-1/2" x 30"	10	5
051131- <b>02633</b>	255L	P150	4-1/2" x 30"	10	5
051131- <b>02634</b>	255L	P120	4-1/2" x 30"	10	5

## 3M™ Green Corps™ Hookit™ Regalite™ 4-1/2" x 30" Fairing Board Sheets 750U and 751U

These sheets utilize a convenient hook-and-loop attachment system for easy placement on and removal from the tool face. The special mineral coating bonded to a durable "E" weight backing is designed to last long and cut fast when using a 3M™ Marine Hookit™ Fairing Board (PNs 83497 or 83978).

Part Number	Product		Size	Sheets Per Sleeve	Sleeves Per Case
	I.D.	Grade			
051131- <b>02637</b>	750U	100E	4-1/2" x 30"	10	5
051131- <b>02638</b>	750U	80E	4-1/2" x 30"	10	5
051131- <b>02639</b>	750U	60E	4-1/2" x 30"	10	5
051131- <b>02640</b>	751U	40E	4-1/2" x 30"	10	5
051131- <b>02641</b>	751U	36E	4-1/2" x 30"	10	5

## 3M™ Marine Hookit™ Facing Material

3M™ Marine Hookit™ Facing Material is a part of the 3M™ Marine Hookit™ Fairing Board/Abrasive Sanding System. The 3M™ Hookit™ Facing Material allows conversion of self-made fairing boards to the 3M™ Hookit™ Attachment System to utilize 4-1/2" x 30" 3M™ Hookit™ High Performance Abrasive Sheets. Use 3M™ General Trim Adhesive (PN08088) for bonding 3M™ Hookit™ Facing Material to wood surface.



Part Number	Roll Size	Rolls Per Case
<b>88044</b>	4-1/8" x 12'	5

Note: Available as a KUT item.

## 3M™ Marine Imperial™ Hookit™ Fairing Board System 740I and 745I

This product earns the 3M Purple color which indicates the latest 3M technology, greatest cost/value and highest quality available. This uniquely blended mineral construction and tough "E" weight backing provides for a fast cutting, longer lasting abrasive. Excellent for stripping paint or sanding marine fairing compounds.

Part Number	Product			Sheets Per Box	Boxes Per Case
	I.D.	Grade	Size		
NEW 051131- <b>01791</b>	745I	80	2-3/4" x 16-1/2"	25	4
NEW 051131- <b>01769</b>	740I	60	2-3/4" x 16-1/2"	25	4
NEW 051131- <b>01793</b>	740I	40	2-3/4" x 16-1/2"	25	4
NEW 051131- <b>01794</b>	740I	36	2-3/4" x 16-1/2"	25	4

# Floor Surfacing Paper Rolls and Discs

## 3M™ Floor Surfacing Paper Type E Rolls

The most economical way to buy sanding paper. Used extensively in Marine applications for "fairing" large areas of hulls, smoothing repair areas, as well as sanding "plugs" down before making molds for casting hulls and deck sections.

	Part Number	Grade	Width	Length	Rolls Per Case
NEW	051115-06875*	20 — 3-1/2	8"	25 yds.	1
NEW	051115-06876**	16 — 4	8"	25 yds.	1
	051144-15299	100 — 2/0	8"	50 yds.	1
	051144-15300	80 — 1/0	8"	50 yds.	1
	051144-15301	60 — 1/2	8"	50 yds.	1
	051144-15302	50 — 1	8"	50 yds.	1
	051115-07938	40 — 1-1/2	8"	50 yds.	1
	051115-07921	36 — 2	8"	50 yds.	1
	051115-07922	30 — 2-1/2	8"	50 yds.	1
	051115-07934	24 — 3	8"	50 yds.	1
	051115-06883	20 — 3-1/2	12"	25 yds.	1
	051115-06882	16 — 4	12"	25 yds.	1
	051144-15287	100 — 2/0	12"	50 yds.	1
	051144-15288	80 — 1/0	12"	50 yds.	1
	051144-15289	60 — 1/2	12"	50 yds.	1
	051144-15290	50 — 1	12"	50 yds.	1
	051115-07937	40 — 1-1/2	12"	50 yds.	1
	051115-07923	36 — 2	12"	50 yds.	1
	051115-07924	30 — 2-1/2	12"	50 yds.	1
	051115-07935	24 — 3	12"	50 yds.	1

\* Replacement for 051144-15974

\*\* Replacement for 051144-15320

## 3M™ Floor Surfacing Paper Discs, Type E, Closed Coat

Used on areas not accessible to drum type sanders. Specify machine and model number when ordering.

Part Number	Grade	Size	Discs Per Min. Pkg.	Discs Per Case
<b>With 4 slots 1/2" long</b>				
051144-20984	60 — 1/2	7" x 7/8"	100	300
051144-20985	50 — 1	7" x 7/8"	100	300
051115-07939	40 — 1-1/2	7" x 7/8"	100	300
051115-07925	36 — 2	7" x 7/8"	100	300
051115-07926	30 — 2-1/2	7" x 7/8"	100	300
051115-07936	24 — 3	7" x 7/8"	100	300
051144-21640	20 — 3-1/2	7" x 7/8"	50	200
051144-21037	16 — 4CMB	7" x 7/8"	50	200
<b>With 8 slots 1-1/8" long</b>				
051144-20958	80 — 1/0	16" x 2"	50	100
051144-20961	36 — 2	16" x 2"	50	100
051144-20962	30 — 2-1/2	16" x 2"	50	100
051115-00438	20 — 3-1/2	16" x 2"	25	25
051144-21027	16 — 4CMB	16" x 2"	25	25

# 3M™ Hookit™ Abrasive Sheets and Accessories

## 3M™ Green Corps™ Hookit™ Regalite™ Sheets 750U and 751U, 2-3/4" Width



3M™ Green Corps™ Hookit™ Regalite™ Sheets utilize a convenient hook-and-loop attachment system for easy placement on and removal from the tool face. The special mineral coating bonded to a durable "E" wt. backing is designed to last long and cut fast when using by hand or with a machine.

Part Number	Product I.D.	Grade	Size	Sheets Per Box	Boxes Per Case
051131-00538	750U	100E	2-3/4" x 16-1/2"	50	5
051131-00539	750U	80E	2-3/4" x 16-1/2"	50	5
051131-00540	750U	60E	2-3/4" x 16-1/2"	50	5
051131-00542	751U	40E	2-3/4" x 16-1/2"	50	5
051131-00543	751U	36E	2-3/4" x 16-1/2"	50	5

## 3M™ Hookit™ Gold Film Sheets 255L, 2-3/4" Width

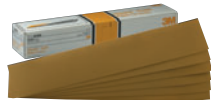

These sheets utilize the convenient hook-and-loop attachment system for easy placement on and removal from the tool face. Designed for dry sanding with air file, hand boards or hand blocks.

Part Number	Product I.D.	Grade	Size	Sheets Per Sleeve	Sleeves Per Case
051131-02469	255L	P220	2-3/4" x 16"	50	5
051131-02470	255L	P180	2-3/4" x 16"	50	5
051131-02472	255L	P150	2-3/4" x 16"	50	5
051131-02473	255L	P120	2-3/4" x 16"	50	5

## 3M™ Hookit™ Hand Blocks

3M™ Hookit™ Hand Blocks are made of a sturdy, durable high-strength material to fit the hand comfortably. These blocks have an embossed 3M™ Hookit™ face for use with 3M™ Hookit™ Regalite™ Sheets. The smaller block (PN05740) is designed to use one-third of a 3M™ Hookit™ Regalite™ Sheet while the larger block (PN05741) uses one-half of a 3M™ Hookit™ Regalite™ Sheet.

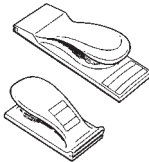

Part Number	Size	Blocks Per Box	Boxes Per Case
051131-05740	2-3/4" x 5"	1	10
051131-05741	2-3/4" x 7-3/4"	1	10

Part Number	Size	Blocks Per Pack	Packs Per Case
-------------	------	-----------------	----------------

### Peggable Package

051131-35740	- No Longer Available -
051131-35741	- No Longer Available -

## 3M™ Hookit™ Soft Hand Block

Block is made of a tough, flexible foam for block sanding flat and contoured areas. 3M™ Hookit™ face provides positive attachment of 3M™ Hookit™ sheets, yet allows easy change and reattachment.



Part Number	Size	Blocks Per Case
051131-05742	2-3/4" x 5"	10

## 3M™ Hookit™ Hand File Board

The 3M™ Hookit™ Hand File Board is a well balanced, durable shop tool, that is resistant to most solvents. The sturdy design provides a non-twisting flat sanding surface. The embossed 3M™ Hookit™ face allows easy attachment and removal of our 3M™ Hookit™ Regalite™ File Sheets.

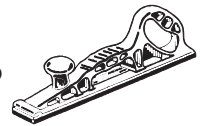

Part Number	Abrasive Size	Boards Per Case
051131-05744	2-3/4" x 16-1/2"	1

## 3M™ Hookit™ Air File Shoe

The 3M™ Hookit™ Air File Shoe has been specially designed for use on all straight air files with 3M™ Hookit™ Regalite™ File Sheets 2-3/4" x 16-1/2". The embossed 3M™ Hookit™ face allows for easy attachment and removal of 3M™ Hookit™ File Sheets while eliminating the need for mechanical clips.



Part Number	Abrasive Size	Shoes Per Case
051131-05748	2-3/4" x 16-1/2"	5

Part Number	Shoes Per Pack	Packs Per Case
-------------	----------------	----------------

### Peggable Package

051131-35748	1	5
--------------	---	---

## 3M™ Hookit™ Air File Shoe

The 3M™ Hookit™ Air File Shoe has been specially designed for use on the Viking V101 mini-type straight-line air file with 3M™ Green Corps™ Hookit™ Regalite™ file sheets. The 3M™ Hookit™ attachment system allows for easy attachment and removal of the sheets, eliminating the need for mechanical clips.

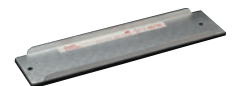

Part Number	Abrasive Size	Shoes Per Case
051131-05750	2-3/4" x 11"	5



# 3M™ Wetordry™ Sandpaper Sheets

## 3M™ Imperial™ Wetordry™ Paper Sheets 213Q

3M™ Imperial™ Wetordry™ Paper Sheets 213Q utilize a premium, aluminum oxide mineral, an improved paper backing, and an optimized construction that results in the following performance advantages: improved rate of cut, increased abrasive life, increased flexibility, and uniform, consistent finish.



Part Number	Product I.D.	Grade	Size	Sheets Per Sleeve	Sleeves Per Case
051131-02035	213Q	P800	9" x 11"	50	5
051131-02036	213Q	P600	9" x 11"	50	5
051131-02037	213Q	P500	9" x 11"	50	5
051131-02038	213Q	P400	9" x 11"	50	5
051131-02039	213Q	P360	9" x 11"	50	5
051131-02040	213Q	P320	9" x 11"	50	5
051131-02041	213Q	P280	9" x 11"	50	5
051131-02042	213Q	P240	9" x 11"	50	5
051131-02043	213Q	P220	9" x 11"	50	5

Part Number	Product I.D.	Grade	Size	Sheets Per Pack	Packs Per Case
051131-32035	213Q	P800	9" x 11"	5	10
051131-32036	213Q	P600	9" x 11"	5	10
051131-32037	213Q	P500	9" x 11"	5	10
051131-32038	213Q	P400	9" x 11"	5	10
051131-32039	213Q	P360	9" x 11"	5	10
051131-32040	213Q	P320	9" x 11"	5	10
051131-32042	213Q	P240	9" x 11"	5	10
051131-32043	213Q	P220	9" x 11"	5	10

## 3M™ Imperial™ Wetordry™ Improved Construction 401Q

This improved Imperial™ Wetordry™ product is constructed of a silicone carbide mineral, better bonding system and more flexible backing. These features will provide faster cut, longer life, more consistent finish which will reduce sanding and buffing time. All grades are packed 5 sleeves per case.



Part Number	Product I.D.	Grade	Size	Sheets Per Sleeve	Sleeves Per Case
051144-02021	401Q	Ultra Fine 1000	5-1/2" x 9"	50	5
051131-02022	401Q	Micro Fine 1200	5-1/2" x 9"	50	5
051131-02023	401Q	Micro Fine 1500	5-1/2" x 9"	50	5
051131-02044	401Q	Micro Fine 2000	5-1/2" x 9"	50	5
051131-02045	401Q	Micro Fine 2500	5-1/2" x 9"	50	5
051131-02034	401Q	Ultra Fine 1000	9" x 11"	50	5
051131-02033	401Q	Micro Fine 1200	9" x 11"	50	5
051131-02032	401Q	Micro Fine 1500	9" x 11"	50	5
051131-02020	401Q	Micro Fine 2000	9" x 11"	50	5
051131-02019	401Q	Micro Fine 2500	9" x 11"	50	5

Part Number	Product I.D.	Grade	Size	Sheets Per Pack	Packs Per Case
051131-32021	401Q	Ultra Fine 1000	9" x 11"	5	10
051131-32022	401Q	Micro Fine 1200	9" x 11"	5	10
051131-32023	401Q	Micro Fine 1500	9" x 11"	5	10
051131-32044	401Q	Micro Fine 2000	9" x 11"	5	10

## 3M™ Wetordry™ Tri-M-ite™ Paper Sheets 411Q, 413Q and 431Q

Use wet or dry for sanding old finishes, fine featheredging plus surface work. It is a silicon carbide, closed coat product bonded with a waterproof resin.



Part Number	Product I.D.	Grade	Size	Sheets Per Sleeve	Sleeves Per Case
051144-02000	411Q	600A	9" x 11"	50	10
051144-02001	411Q	500A	9" x 11"	50	5
051144-02002	413Q	400A	9" x 11"	50	10
051144-02003	413Q	360A	9" x 11"	50	5
051144-02004	413Q	320A	9" x 11"	50	10
051144-02005	413Q	280A	9" x 11"	50	5
051144-02006	413Q	240A	9" x 11"	50	5
051144-02007	413Q	220A	9" x 11"	50	10
<b>A Weight</b>					
051144-02088	431Q	180C	2-3/4" x 17-1/2"	100	10
051144-10695	431Q	400C	9" x 11"	50	10
051144-10697	431Q	320C	9" x 11"	50	10
051144-10699	431Q	240C	9" x 11"	50	10
051144-02014	431Q	180C	9" x 11"	50	5
051144-02015	431Q	150C	9" x 11"	50	5
051144-02016	431Q	120C	9" x 11"	50	5
051144-02017	431Q	100C	9" x 11"	50	5
051144-02018	431Q	80C	9" x 11"	50	5
051144-02019	431Q	60C	9" x 11"	50	5
<b>C Weight</b>					

## 3M™ Wetordry™ Fabricut™ Cloth Silicon Carbide Sheets 481W and 483W

A waterproof open coat mesh cloth that permits easy cleaning of sanding residue for improved cutting efficiency. Used to the best advantage where filling or loading is a problem.



Part Number	Product I.D.	Grade	Size	Sheets Per Min. Pkg.	Sheets Per Case
051144-10290	481W	320	9" x 11"	25	250
051144-10455	481W	220	9" x 11"	25	250
051144-10456	483W	180	9" x 11"	25	250
051144-10457	483W	150	9" x 11"	25	250
051144-10458	483W	120	9" x 11"	25	250
051144-10459	483W	100	9" x 11"	25	250
051144-10460	483W	80	9" x 11"	25	250

# 3M™ Wetordry™ Accessories

## 3M™ Wetordry™ Rubber Squeegees

Made of flexible rubber in two sizes. The 3" x 2" size is used for removing swarf created when sanding with water while the 2-3/4" x 4-1/4" size is used for applying glazing putty and plastic filler.



Part Number	Size	Each Per Case
051144-05517	2-3/4" x 4-1/4"	50
051144-05518	3" x 2"	50

## 3M™ Wetordry™ Bucket

A durable rubber 3M bucket designed for use when wet sanding. Each bucket has a tray packed inside to store 3M™ Wetordry™ paper, squeegees and blocks.



Part Number	Buckets Per Case
051131-02513	10

## 3M™ No. 20 Wetordry™ Sponge Pad

A firm hand sanding pad to be used with a three-fold wrap of 3M™ Wetordry™ Tri-M-ite™ Paper Sheets, 3M™ Imperial™ Wetordry™ Color Sanding Paper Sheets or 3M™ Production™ Gold Paper Sheets to make hand sanding easier and more efficient.



Part Number	Pads Per Box	Pads Per Case
051131-05526	5	50

# 9" x 11" and Miscellaneous Sheets

## 3M™ Imperial™ Sheets 740I and 745I

This product earns the 3M Purple color which indicates the latest 3M technology, greatest cost/value and highest quality available. This uniquely blended mineral construction and tough "E" weight backing provides for a fast cutting, long-lasting abrasive. Excellent for stripping paint or sanding marine fairing compounds.



Part Number	Product		Size	Sheets Per Box	Boxes Per Case
	I.D.	Grade			
051131-02254	745I	P120E	2-3/4" x 17-1/2"	50	4
051131-02255	745I	P100E	2-3/4" x 17-1/2"	50	4
051131-02256	745I	P80E	2-3/4" x 17-1/2"	50	4
051131-02258	740I	40E	2-3/4" x 17-1/2"	50	4
051131-02259	740I	36E	2-3/4" x 17-1/2"	50	4

# 9" x 11" and Miscellaneous Sheets

## 3M™ Production™ Paper Sheets 210N, 336I, 346I and 346U

Dry sanding only by machine or hand on fiberglass, wood or metal. Open coat with tough aluminum oxide mineral.



Part Number	Product I.D.	Grade	Size	Sheets Per Sleeve	Sleeves Per Case
<b>A Weight</b>					
051144-02103	210N	220A	9" x 11"	100	10
051144-02104	210N	180A	9" x 11"	100	10
051144-02106	210N	120A	9" x 11"	100	10
051144-02107	210N	100A	9" x 11"	100	10
051144-02108	210N	80A	9" x 11"	100	10
<b>C&amp;D Weight</b>					
051144-02112	336I	150C	9" x 11"	100	10
051144-02113	336I	120C	9" x 11"	100	10
051144-02114	336I	100C	9" x 11"	100	10
051144-02115	346I	80D	9" x 11"	50	10
051144-02116	346I	60D	9" x 11"	50	10
051144-02117	346I	50D	9" x 11"	50	10
051144-02118	346U	40D	9" x 11"	50	5
051144-02119	346U	36D	9" x 11"	50	5
051144-02133	336I	120C	2-3/4" x 17-1/2"	200	10
051144-02134	336I	100C	2-3/4" x 17-1/2"	200	10
051144-02135	346I	80D	2-3/4" x 17-1/2"	100	10
051144-02136	346I	60D	2-3/4" x 17-1/2"	100	10
051144-02138	346U	40D	2-3/4" x 17-1/2"	100	5
051144-02139	346U	36D	2-3/4" x 17-1/2"	100	5
<b>D Weight</b>					
051144-02176	240N	60D	3-2/3" x 9"	200	10

Part Number	Product I.D.	Grade	Size	Sheets Per Pack	Packs Per Case
<b>Packaged</b>					
051131-32112	336I	150C	9" x 11"	5	10
051131-32113	240D	120C	9" x 11"	5	10
051131-32114	336I	100C	9" x 11"	5	10
051131-32115	346I	80D	9" x 11"	5	10
051131-32116	346I	60D	9" x 11"	5	10
051131-32118	346U	40D	9" x 11"	5	10
051131-32119	346U	36D	9" x 11"	5	10

## 3M™ Production™ Fre-Cut™ Paper Sheets 245N

Dry sanding only. Specially treated open coat paper with aluminum oxide mineral resists loading when sanding on fiberglass, metal or wood.



Part Number	Product I.D.	Grade	Size	Sheets Per Sleeve	Sleeves Per Case
<b>D Weight</b>					
051144-02338	245N	80D	4-1/2" x 11"	100	10
051144-02393	245N	80D	9" x 11"	50	10
051144-02394	245N	60D	9" x 11"	50	10
051144-02397	– Suggested Replacement PN02225 –				
051144-02400	245N	80D	2-3/4" x 17-1/2"	100	10

## 3M™ Production™ Resinite™ Fre-Cut™ Gold Paper Sheets 216U

3M™ Production™ Resinite™ Fre-Cut™ Gold Paper Sheets 216U utilize a premium, aluminum oxide mineral, an improved paper backing, and total construction that results in the following performance advantages: fast rate of cut, good flexibility, long abrasive life and uniform, consistent finish.



Part Number	Product I.D.	Grade	Size	Sheets Per Sleeve	Sleeves Per Case
<b>Packaged</b>					
051131-02536	216U	P800	9" x 11"	50	5
051131-02537	216U	P600	9" x 11"	50	5
051131-02538	216U	P500	9" x 11"	50	5
051131-02539	216U	P400	9" x 11"	50	5
051131-02540	216U	P360	9" x 11"	50	5
051131-02541	216U	P320	9" x 11"	50	5
051131-02542	216U	P280	9" x 11"	50	5
051131-02543	216U	P240	9" x 11"	50	5
051131-02544	216U	P220	9" x 11"	50	5
051131-02545	216U	P180	9" x 11"	50	5
051131-02546	216U	P150	9" x 11"	50	5
051131-02547	216U	P120	9" x 11"	50	5
051131-02548	216U	P100	9" x 11"	50	5
051131-02549	216U	P80	9" x 11"	50	5
051131-02551	216U	P320	3-2/3" x 9"	100	5
051131-02552	216U	P220	3-2/3" x 9"	100	5
051131-02553	216U	P180	3-2/3" x 9"	100	5
051131-02554	216U	P150	3-2/3" x 9"	100	5
051131-02566	216U	P240	2-3/4" x 17-1/2"	50	5
051131-02567	216U	P220	2-3/4" x 17-1/2"	50	5
051131-02568	216U	P180	2-3/4" x 17-1/2"	50	5
051131-02569	216U	P150	2-3/4" x 17-1/2"	50	5

Part Number	Product I.D.	Grade	Size	Sheets Per Pack	Packs Per Case
<b>Packaged</b>					
051131-32541	216U	P320	9" x 11"	5	10
051131-32544	216U	P220	9" x 11"	5	10
051131-32545	216U	P180	9" x 11"	5	10

## 3M™ Tri-M-ite™ Fre-Cut™ Paper Sheets 415N and 415U (Original Construction)

Dry sanding only by hand or machine. A specially treated paper with sharp silicon carbide mineral that resists loading when working on wood, plastic or fiberglass. Well suited for varnish sanding applications.



Part Number	Product I.D.	Grade	Size	Sheets Per Min. Pkg.	Sheets Per Case
051144-14190	415N	320A	9" x 11"	100	1000
051144-14188	415N	280A	9" x 11"	100	1000
051144-14186	415N	240A	9" x 11"	100	1000
051144-14183	415U	220A	9" x 11"	100	1000
051144-14181	415U	180A	9" x 11"	100	1000
051144-14179	415U	150A	9" x 11"	100	1000
051144-14177	415U	120A	9" x 11"	100	1000
051144-14175	415U	100A	9" x 11"	100	1000

# 9" x 11" and Miscellaneous Sheets

## 3M™ Tri-M-ite™ Fre-Cut™ Paper Sheets 405N, 414N and 435N

Dry sanding only by hand or machine. A specially treated paper with sharp silicon carbide mineral resists loading when working on wood, plastic or fiberglass.



Part Number	Product		Size	Sheets Per Sleeve	Sleeves Per Case
	I.D.	Grade			
<b>A Weight</b>					
051144-10240	405N	500A	9" x 11"	100	10
051144-02342	414N	400A	9" x 11"	100	10
051144-10242	405N	360A	9" x 11"	100	10
051144-02344	414N	320A	9" x 11"	100	10
051144-02345	414N	280A	9" x 11"	100	10
051144-02346	414N	240A	9" x 11"	100	10
051144-02347	414N	220A	9" x 11"	100	10
051144-02348	414N	180A	9" x 11"	100	10
051144-02349	414N	150A	9" x 11"	100	10
051144-02350	414N	120A	9" x 11"	100	10
051144-02351	414N	100A	9" x 11"	100	10
051144-02352	414N	80A	9" x 11"	50	10
051144-10288	414N	320A	2-3/4" x 17-1/2"	200	10
051144-02359	414N	220A	2-3/4" x 17-1/2"	200	10
051144-02360	414N	180A	2-3/4" x 17-1/2"	200	10
051144-02361	414N	150A	2-3/4" x 17-1/2"	200	10
051144-02362	414N	120A	2-3/4" x 17-1/2"	200	10
051144-10270	405N	400A	3-2/3" x 9"	400	10
051144-02380	– Superseded by PN02551 –				
051144-10273	405N	280A	3-2/3" x 9"	400	10
051144-02382	414N	240A	3-2/3" x 9"	400	10
051144-02383	– Superseded by PN02552 –				
051144-02384	– Superseded by PN02553 –				
051144-02385	– Superseded by PN02554 –				
051144-02386	414N	120A	3-2/3" x 9"	400	10
051144-02387	414N	100A	3-2/3" x 9"	400	10
051144-10260	405N	220A	4-1/2" x 11"	200	10
051144-10261	405N	180A	4-1/2" x 11"	200	10
051144-10054	414N	120A	4-1/2" x 11"	200	10
<b>C Weight</b>					
051144-02353	435N	180C	9" x 11"	100	10
051144-02355	435N	120C	9" x 11"	100	10
051144-02356	435N	100C	9" x 11"	100	10

## 3M™ Green Corps™ Production™ Resin Paper Sheets 246U

Tough mineral bond construction along with special treatment to resist loading means long-lasting, fast-cutting abrasive. Excellent for intermediate sanding, shaping and fairing of boat hulls.



Part Number	Product			Sheets Per Box	Boxes Per Case
	I.D.	Grade	Size		
051131-02225	246U	80D	3-2/3" x 9"	100	10
051131-02220	246U	80D	2-3/4" x 17-1/2"	100	5
Part Number	Product			Sheets Per Pack	Packs Per Case
	I.D.	Grade	Size		
<b>Packaged</b>					
051131-32220	246U	80D	2-3/4" x 17-1/2"	5	10

## 3M™ Green Corps™ Production™ Resin Bond Paper Sheets 252U

Dry sanding only with hand or air file. Special mineral coating plus improved mineral bond means long-lasting, fast-cutting abrasive life. Excellent for rough sanding, shaping and fairing of hulls.



Part Number	Product			Sheets Per Box	Boxes Per Case
	I.D.	Grade	Size		
<b>E Weight</b>					
051131-02226	252U	40E	3-2/3" x 9"	100	10
051131-02227	252U	36E	3-2/3" x 9"	100	10
051144-02221	252U	40E	2-3/4" x 17-1/2"	100	5
051144-02222	252U	36E	2-3/4" x 17-1/2"	100	5
Part Number	Product			Sheets Per Pack	Packs Per Case
	I.D.	Grade	Size		
<b>Packaged — E Weight</b>					
051131-32221	252U	40E	2-3/4" x 17-1/2"	5	10
051131-32222	252U	36E	2-3/4" x 17-1/2"	5	10

## 3M™ Crystal Bay™ Emery and Crocus Cloth Sheets 001K

Emery Cloth for light metal sanding. Primarily a polishing agent but also used for removing rust and corrosion from metal surfaces.



Part Number	Product			Sheets Per Sleeve	Sleeves Per Case
	I.D.	Grade	Size		
051144-02431	001K	Fine	9" x 11"	50	5
051144-02432	001K	Medium	9" x 11"	50	5
051144-02433	001K	Coarse	9" x 11"	50	5
051144-02435	001K	Crocus	9" x 11"	50	5

# 9" x 11" Sheet Accessories

## 3M™ Sanding Block

A pliable rubber block which holds the sandpaper securely during wet or dry sanding operations. It utilizes a 9" x 11" sheet torn or folded into fourths to make 2-3/4" x 9" sheets or for convenience use 3M pre-cut 2-3/4" x 9" sheets.



Part Number	Sheet Size	Blocks Per Case
051144- <b>05519</b>	2-3/4" x 9"	10

Part Number	Blocks Per Pack	Packs Per Case
-------------	-----------------	----------------

### Peggable Package

051131- <b>35519</b>	1	5
----------------------	---	---

## 3M™ Rubber Sanding Block

The 3M™ Rubber Sanding Block is for use with 3M™ Wetordry™ sanding sheets and dry 9" x 11" sanding sheets for block sanding. This block is pliable for mild contours and designed to hold sandpaper sheets securely during wet or dry sanding operations. It utilizes a 9" x 11" sheet torn or folded into thirds to make 3" x 11" sheets.



Part Number	Sheet Size	Blocks Per Case
051131- <b>05520</b>	3" x 11"	10

## Plastic Bulk Abrasives Rack 503

Each rack contains 8 plastic trays including bulk abrasives labels and headers kit. Case dimensions: 14" x 16.5" x 34.5".

Part Number	Racks Per Case
<b>NEW</b> 051135- <b>64666</b>	1

(Not stocked as a 3M item. Contact your Marine Sales Representative for ordering information.)

# Softback Sanding Sponges

## 3M™ Softback Sanding Sponges, 4-1/2" x 5-1/2"

3M™ Softback Sanding Sponges are an innovation in coated abrasives for hand sanding applications. These sanding sponges provide flexibility and conformability to allow for sanding by hand in areas inaccessible to machine sanders. 3M™ Softback Sanding Sponges feature aluminum oxide mineral coated on a foam pad with a waterproof bonding system. That's right, they can be used either wet or dry when sanding on wood, fiberglass/gelcoat, marine paints, metals and plastics.



Part Number	Grade	Sponges Per Box	Boxes Per Case
051131- <b>02600</b>	Microfine/1200-1500	20	6
051131- <b>02601</b>	Ultrafine/800-1000	20	6
051131- <b>02602</b>	Superfine/500-600	20	6
051131- <b>02604</b>	Fine/320-400	20	6
051131- <b>02606</b>	Medium/120-180	20	6

Part Number	Grade	Sponges Per Box
-------------	-------	-----------------

### Bulk

051115- <b>06964</b>	Superfine/500-600	250
051115- <b>06965</b>	Fine/320-400	250
051115- <b>06966</b>	Medium/120-180	250

# Cloth Utility Rolls

## 3M™ Tri-M-ite™ Elek-Tro-Cut™ Cloth Utility Rolls 211K and 241K

For light deburring, clean-up, blending and finishing metal surfaces.



Part Number	Product I.D.	Grade	Width	Length	Rolls Per Case
051144-05002	211K	320J	1"	50 yds.	5
051144-05003	211K	280J	1"	50 yds.	5
051144-05004	211K	240J	1"	50 yds.	5
051144-05005	211K	220J	1"	50 yds.	5
051144-05006	211K	180J	1"	50 yds.	5
051144-05007	211K	150J	1"	50 yds.	5
051144-05008	211K	120J	1"	50 yds.	5
051144-05009	211K	100J	1"	50 yds.	5
051144-05022	211K	320J	1-1/2"	50 yds.	5
051144-05024	211K	240J	1-1/2"	50 yds.	5
051144-05025	211K	220J	1-1/2"	50 yds.	5
051144-05026	211K	180J	1-1/2"	50 yds.	5
051144-05027	211K	150J	1-1/2"	50 yds.	5

## 3M™ Tri-M-ite™ Elek-Tro-Cut™ Cloth Utility Rolls 211K and 241K (continued)

Part Number	Product I.D.	Grade	Width	Length	Rolls Per Case
051144-05028	211K	120J	1-1/2"	50 yds.	5
051144-05029	211K	100J	1-1/2"	50 yds.	5
051144-05030	211K	80J	1-1/2"	50 yds.	5
051144-05032	241K	50X	1-1/2"	50 yds.	5
051144-05042	211K	320J	2"	50 yds.	5
051144-05043	211K	280J	2"	50 yds.	5
051144-05044	211K	240J	2"	50 yds.	5
051144-05045	211K	220J	2"	50 yds.	5
051144-05046	211K	180J	2"	50 yds.	5
051144-05047	211K	150J	2"	50 yds.	5
051144-05048	211K	120J	2"	50 yds.	5
051144-05049	211K	100J	2"	50 yds.	5
051144-05050	211K	80J	2"	50 yds.	5
051144-05052		- No Longer Available -			
051144-05054		- No Longer Available -			

# Miscellaneous Abrasive Racks and Accessories

## 3M™ Dry Guide Coat Cartridge and Kit

Dry powder with applicator used to highlight surface imperfections and sand scratches prior to finishing with abrasives. Can be used on marine fillers, primers, paints and gelcoat. Contains no solvents. Kit comes with applicator pad.



Part Number	Description	Quantity Per Case
051131-05860	50 Gram Cartridge	10
051131-05861	50 Gram Cartridge and Applicator Kit	6

## 3M Coated Abrasive Rapid Transit System C.A.R.T.S.

This three-shelf cart is made of eighteen gauge sturdy metal, with fourteen gauge uprights and 5" rubber caster wheels. The cart has a capacity of 400 pounds in its three large storage areas. The dimensions are 19-3/4" x 29-1/2" x 32" high. Some assembly is required. **NOT A 3M PRODUCT. TO ORDER, CALL SHOPWARE AT 1-800-877-9344.**



Part Number	Each Per Case
051131-02510	1

(Not stocked as a 3M item)

## 3M™ Professional Job Packed 9" x 11" Waterfall Rack

3M™ Professional Job Packed 9" x 11" Waterfall rack is designed to hold 9" x 11" abrasive sheets packs (5 sheets per pack) in a waterfall display. The rack holds 6 part numbers and displays product using minimal square footage. Dimensions are 14" high x 9" wide x 13-1/4" deep.



**NOTE: PRODUCTS DO NOT COME WITH THE DISPLAY.**

Part Number	Racks Per Case
NEW 051131-32498	1

## 3M Portable Automotive Refinish Table Stand P.A.R.T.S.

This table top frame has rounded corners on the shelf and legs and is made of sixteen gauge steel tubular frame construction. It is easily adjustable to four positions. The frame weights only 30-1/2 pounds. The maximum weight limit on the table top form is 200 pounds. The dimensions (table top form) are 30-1/2" wide x 36" long x 34-1/4" high. Some assembly is required.



**NOT A 3M PRODUCT. TO ORDER, CALL SHOPWARE AT 1-800-877-9344.**

Part Number	Each Per Case
051131-02514	1

(Not stocked as a 3M item)

## 3M Abrasive Organizer

This organizer is red in color with a white 3M™ logo on the door. It can be hung on a wall or placed on a shelf. It has 2 hinged doors and is constructed of 24 gauge steel. It features 13 adjustable shelves and 1 permanent shelf with locking clasp for use with padlock. The dimensions are 32- 5/8" wide, 12-1/8" deep and 30 1/6" high. The weight is 54 pounds.



Not a 3M product. To order, call Shopware at 1-800-877-9344. **NOTE: PRODUCTS DO NOT COME WITH THE ORGANIZER.**

Part Number	Each Per Case
051131-02500	1

(Not stocked as a 3M item)

# Abrasive Belts

## 3M™ Purple Belts 761D

3M™ Purple Belts 761D are a P graded 3M™ Regalite™ construction which provides increased cut rate, more uniform finish, higher stock removal with less heat and loading, and long life for wood sanding. 3M™ Purple Belts 761D also feature a butt splice which allows for unidirectional sanding for extended life and reduced abrasive cost on the job you're doing.



Part Number	Product I.D.	Grade	Belts Per Box	Belts Per Case
<b>3" x 18"</b>				
051144- <b>81393</b>	761D	50Y	5	25
051144- <b>81394</b>	761D	60Y	5	25
051144- <b>81395</b>	761D	80Y	5	25
051144- <b>81396</b>	761D	P100Y	5	25
051144- <b>81397</b>	761D	P120Y	5	25
051144- <b>81398</b>	761D	P150Y	5	25
<b>3" x 21"</b>				
Fits Skil no's. 594, 595; Porter Cable no's. 136, 153; Miller Falls no. 830, Wards no. 8533; Stanley no. H493; Rockwell no's. 90, 91, 236 and 237.				
051144- <b>81399</b>	761D	50Y	5	25
051144- <b>81400</b>	761D	60Y	5	25
051144- <b>81401</b>	761D	80Y	5	25
051144- <b>81402</b>	761D	P100Y	5	25
051144- <b>81403</b>	761D	P120Y	5	25
051144- <b>81404</b>	761D	P150Y	5	25
<b>3" x 24"</b>				
Fits Black & Decker no's. U-144, U-244, U-346, 454, 470, 471, 654, 670, 671, 7450, 7460; Mail no's. 30, 31; Porter Cable no's. A3, B3, G3, T3, T33, 360; Stanley no. H-31				
051144- <b>81410</b>	761D	50Y	5	25
051144- <b>81411</b>	761D	60Y	5	25
051144- <b>81412</b>	761D	80Y	5	25
051144- <b>81413</b>	761D	P100Y	5	25
051144- <b>81414</b>	761D	P120Y	5	25
051144- <b>81415</b>	761D	P150Y	5	25
<b>4" x 24"</b>				
Fits Porter Cable no. 564, Sears no. 2239; Stanley nos. 494, 496, 497				
051144- <b>81429</b>	761D	50Y	5	25
051144- <b>81430</b>	761D	60Y	5	25
051144- <b>81431</b>	761D	80Y	5	25
051144- <b>81432</b>	761D	P100Y	5	25
051144- <b>81433</b>	761D	P120Y	5	25
051144- <b>81434</b>	761D	P150Y	5	25

## 3M™ Three-M-ite™ Resin Bond Cloth Belts Open Coat 240D



Used in grinding and finishing a wide variety of materials such as plastics, fiberglass, soft woods, and non-ferrous metals. This product is a sharp, durably constructed belt with greater heat and moisture resistance than glue types. The combination of a drills cloth and the resin-over-resin bond provides greater firmness, body and longer life.

Part Number	Product I.D.	Grade	Belts Per Min. Pkg.	Belts Per Case
<b>3" x 21"</b>				
Fits Skil Nos. 594, 595; Porter Cable Nos. 136, 153; Miller Falls No. 830; Wards No. 8533; Stanley No. H493; Rockwell Nos. 90, 91, 236, 237;				
051144- <b>27495</b>	240D	120X	10	50
051144- <b>27496</b>	240D	100X	10	50
051144- <b>27497</b>	240D	80X	10	50
051144- <b>27498</b>	240D	60X	10	50
051144- <b>27499</b>	240D	50X	5	25
051144- <b>27500</b>	– No Longer Available –			
051144- <b>27501</b>	– No Longer Available –			
<b>3" x 23-3/4"</b>				
Fits Skil "ZP" Nos. 9,448 and 9,449; Thor Torpedo Plane; Stanley No. H-31;				
051144- <b>27478</b>	– No Longer Available –			
051144- <b>27479</b>	– No Longer Available –			
051144- <b>27480</b>	– No Longer Available –			
051144- <b>27481</b>	– No Longer Available –			
051144- <b>27483</b>	– No Longer Available –			
<b>3" x 24"</b>				
Fits Black & Decker Nos. U-144, U-244; U-346, 454, 470, 471, 654, 670, 671, 7450, 7460; Mail Nos. 30, 31; Porter Cable A3, B3, G3, T3, T33, No. 360; Stanley No. H-31;				
051144- <b>27468</b>	240D	180X	10	50
051144- <b>27469</b>	– No Longer Available –			
051144- <b>27470</b>	240D	120X	10	50
051144- <b>27471</b>	240D	100X	10	50
051144- <b>27472</b>	240D	80X	10	50
051144- <b>27473</b>	240D	60X	10	50
051144- <b>27474</b>	240D	50X	5	25
051144- <b>27475</b>	– No Longer Available –			
051144- <b>27476</b>	– No Longer Available –			
051144- <b>27477</b>	– No Longer Available –			
<b>4" x 21-3/4"</b>				
Fits Skil Nos. 400, 405, 455, 800 and 805; Shopmate Nos. 1860, 2530; Electro No. 400; McGraw-Edison No. 3530.				
051144- <b>27485</b>	240D	120X	10	50
051144- <b>27486</b>	– No Longer Available –			
051144- <b>27487</b>	– No Longer Available –			
051144- <b>27488</b>	– No Longer Available –			
051144- <b>27489</b>	240D	50X	5	25
<b>4" x 24"</b>				
Fits Porter Cable No. 564; Sears No. 2239; Stanley Nos. 494, 496, 497;				
051144- <b>27458</b>	– No Longer Available –			
051144- <b>27459</b>	– No Longer Available –			
051144- <b>27460</b>	240D	120X	10	50
051144- <b>27461</b>	240D	100X	10	50
051144- <b>27462</b>	240D	80X	10	50
051144- <b>27463</b>	240D	60X	10	50
051144- <b>27464</b>	240D	50X	5	25
051144- <b>27465</b>	– No Longer Available –			
051144- <b>27466</b>	– No Longer Available –			
051144- <b>27467</b>	– No Longer Available –			
<b>6" x 48"</b>				
051144- <b>27421</b>	240D	120X	10	20
051144- <b>27422</b>	240D	100X	10	20
051144- <b>27423</b>	240D	80X	20	20
051144- <b>27425</b>	240D	60X	20	20
051144- <b>27426</b>	240D	50X	10	20
051144- <b>27428</b>	– No Longer Available –			



## 3M™ Stikit™ Dust-Free Sanding Discs and Sheets Availability Grid



Size and Grade	3M™ Imperial™ Stikit™ Dust-Free Disc Rolls 334U & 734U	3M™ Imperial™ Stikit™ Dust-Free 740I & 745I	3M™ Stikit™ Dust-Free Gold Film Disc Rolls 255L	3M™ Stikit™ Dust-Free Gold "C" Weight Disc Rolls 236U (Non-Staining Fre-Cut™)	3M™ Stikit™ Dust-Free Gold Disc Rolls 216U	3M™ Green Corps™ Stikit™ Dust-Free Production™ Discs 246U & 251U	
2-3/4" x 16"	100						
	80						
	40						
	36						
5" Diameter	2500						
	2000						
	1500						
	1200						
	1000						
	800						
	600						
	500	00405			88707		
	400	00406			88706	01619	
	360	00407					
	320	00408			88705	01620	
	280					01621	
	240	00410			88704	01622	
	220	00411			88703	01623	
	180				88702	01624	
	150	00413			88701	01625	
	120	00414			88700	01626	
	100	00415			86499	01627	
	80				86498	01628	01561*
	60						
40						01665	
36							

\* Fre-Cut™ Discs

## 3M™ Stikit™ Dust-Free Sanding Discs and Sheets Availability Grid

Size and Grade	3M™ Imperial™ Stikit™ Dust-Free Disc Rolls 334U & 734U	3M™ Imperial™ Stikit™ Dust-Free 740I & 745I	3M™ Stikit™ Dust-Free Gold Film Disc Rolls 255L	3M™ Stikit™ Dust-Free Gold “C” Weight Disc Rolls 236U (Non-Staining Fre-Cut™)	3M™ Stikit™ Dust-Free Gold Disc Rolls 216U	3M™ Green Corps™ Stikit™ Dust-Free Production™ Discs 246U & 251U
6" Diameter	1500					
	1200					
	1000					
	800					
	600					
	500	00417		01372	86487	01633
	400	00418		01373	86486	01634
	360	00419		01374		
	320	00420		01375	86485	01635
	280	00421		01376		01636
	240	00422		01377	86484	01637
	220	00423		01378	86483	01638
	180	00424		01379	86482	01639
	150	00425		01380	86481	01640
	120	00426	00469	01381	86480	01641
	100	00427	00470	01382	86479	01642
80	00428	00471	01383	86478	01643	
40		00473			01566*	
36		00474			01667	
8" Diameter	400					01668
	320					
	240					
	220					
	180					
	150					
	120		00475			
	100		00476			
	80		00477			01569*
	40		00479			01660
36		00480			01661	

\* Fre-Cut™ Discs

## 3M™ Hookit™ II and Hookit™ Dust-Free Sanding Discs and Sheets Availability Grid



Size and Grade	3M™ Imperial™ Hookit™ II Dust-Free Discs 334U & 734U	3M™ Imperial™ Hookit™ II Dust-Free Discs 740I & 745I	3M™ Hookit™ II Dust-Free Finishing Film Discs 260L	3M™ Hookit™ Dust-Free Gold Film Discs 255L	Fein® Pattern 3M™ Hookit™ Dust-Free Gold Film Discs 255L	3M™ Hookit™ Dust-Free Finishing Film Discs 260L	3M™ Green Corps™ Hookit™ Regalite™ Dust-Free Discs/Sheets 750U & 751U	Fein® Pattern 3M™ Green Corps™ Hookit™ Regalite™ Dust-Free Discs 750U & 751U
2-3/4" x 16"	100						00638	
	80						00639	
	40						00642	
	36						00643	
5" Diameter	2500							
	2000							
	1500			00751				
	1200			00752				
	1000			00753		01053		
	800			00754				
	600			00755		01055		
	500							
	400				01057			
	320				01059			
	280				01060			
	240							
	220				01062			
	180				01063			
	150				01064			
	120				01065			
100				01066				
80				01067				
60								
40								

Fein® is a registered trademark of Fein Power Tools Inc.

# 3M™ Hookit™ II and Hookit™ Dust-Free Sanding Discs and Sheets Availability Grid

Size and Grade	3M™ Imperial™ Hookit™ II Dust-Free Discs 334U & 734U	3M™ Imperial™ Hookit™ II Dust-Free Discs 740I & 745I	3M™ Hookit™ II Dust-Free Finishing Film Discs 260L	3M™ Hookit™ Dust-Free Gold Film Discs 255L	Fein® Pattern 3M™ Hookit™ Dust-Free Gold Film Discs 255L	3M™ Hookit™ Dust-Free Finishing Film Discs 260L	3M™ Green Corps™ Hookit™ Regalite™ Dust-Free Discs/Sheets 750U & 751U	Fein® Pattern 3M™ Green Corps™ Hookit™ Regalite™ Dust-Free Discs 750U & 751U
6" Diameter	1500		00750			01050		
	1200		00768			01068		
	1000		00769			01069		
	800		00770			01070		
	600		00771			01071		
	500	00772			01072			
	400	00773			01073			
	360	00774			01074			
	320	00775			01075	01044		
	280	00776			01076			
	240				01077			
	220	00778			01078	01045		
	180	00779			01079			
	150	00780			01080	01046		
	120	00781	00784		01081	01047		
	100	00782	00785		01082	01048		00552
	80	00783	00786		01083	01049	00612	00553
	60							00554
	40		00787				00615	00555
	36		00788				00616	00556
8" Diameter	120	00789						
	100		00790/00794				00620	
	80		00791/00795				00621	
	40		00792/00796				00624	
	36		00793				00625	

Fein® is a registered trademark of Fein Power Tools Inc.

# 3M™ Stikit™ Dust-Free Abrasives

## 3M™ Imperial™ Stikit™ Dust-Free Disc Rolls 334U and 734U

This product earns the 3M Purple color which indicates the latest 3M technology, greatest cost/value and highest quality available. 3M™ Imperial™ Stikit™ Dust-Free Disc Rolls 334U and 734U are high-performance discs designed to cut faster and last longer enabling the user to obtain maximum usage from each disc. The 334U discs (grades P220-P500) are constructed of a high-performance aluminum oxide mineral, and the 734U discs (P80-P180) are constructed of a uniquely blended mineral. Both mineral systems are excellent for use on tough marine gelcoat, paint and primer systems.



## 3M™ Imperial™ Stikit™ Dust-Free Discs 740I and 745I

This product earns the 3M Purple color which indicates the latest 3M technology, greatest cost/value and highest quality available. 3M™ Imperial™ Stikit™ Dust-Free Film Disc Rolls 740I and 745I are pre-punched with standard hole patterns for dust-free sanding and are designed to be used with 3M™ Stikit™ Dust-Free Disc Pads. This uniquely blended mineral construction and tough "E" weight backing provides for a fast cutting, long-lasting abrasive. Excellent for stripping paint or sanding marine fairing compounds.



Part Number	Product		Size	Discs Per Roll	Rolls Per Case
	I.D.	Grade			
051131-00405	334U	P500	5"	100	4
051131-00406	334U	P400	5"	100	4
051131-00407	334U	P360	5"	100	4
051131-00408	334U	P320	5"	100	4
051131-00410	334U	P240	5"	100	4
051131-00411	334U	P220	5"	100	4
051131-00413	734U	P150	5"	100	4
051131-00414	734U	P120	5"	100	4
051131-00415	734U	P100	5"	100	4
051131-00417	334U	P500	6"	100	4
051131-00418	334U	P400	6"	100	4
051131-00419	334U	P360	6"	100	4
051131-00420	334U	P320	6"	100	4
051131-00421	334U	P280	6"	100	4
051131-00422	334U	P240	6"	100	4
051131-00423	334U	P220	6"	100	4
051131-00424	734U	P180	6"	100	4
051131-00425	734U	P150	6"	100	4
051131-00426	734U	P120	6"	100	4
051131-00427	734U	P100	6"	100	4
051131-00428	734U	P80	6"	100	4

Part Number	Product		Size	Discs Per Roll	Rolls Per Case
	I.D.	Grade			
051131-00469	745I	P120E	6"	50	4
051131-00470	745I	P100E	6"	50	4
051131-00471	745I	P80E	6"	50	4
051131-00473	740I	40E	6"	50	4
051131-00474	740I	36E	6"	50	4
051131-00475	745I	P120E	8"	25	4
051131-00476	745I	P100E	8"	25	4
051131-00477	745I	P80E	8"	25	4
051131-00479	740I	40E	8"	25	4
051131-00480	740I	36E	8"	25	4
<b>12 Hole</b>					
051131-00481	745I	P80E	8"	25	4
051131-00482	740I	40E	8"	25	4
051131-00483	740I	36E	8"	25	4

# 3M™ Stikit™ Dust-Free Abrasives

## 3M™ Stikit™ Dust-Free Gold Film Disc Rolls 255L

3M™ Stikit™ Dust-Free Gold Film Disc Rolls 255L are prepunched with standard hole patterns for dust-free sanding and are designed to be used with 3M™ Stikit™ Dust-Free Disc Pads. This pressure-sensitive adhesive disc is constructed of a high performance aluminum oxide mineral strongly bonded to a smooth film backing. Cuts fast, lasts long, and leaves a consistent finish.



Part Number	Product I.D.	Grade	Size	Discs Per Roll	Rolls Per Case
051131-01372	255L	P500	6"	125	4
051131-01373	255L	P400	6"	125	4
051131-01374	255L	P360	6"	125	4
051131-01375	255L	P320	6"	125	4
051131-01376	255L	P280	6"	125	4
051131-01377	255L	P240	6"	125	4
051131-01378	255L	P220	6"	125	4
051131-01379	255L	P180	6"	125	4
051131-01380	255L	P150	6"	125	4
051131-01381	255L	P120	6"	125	4
051131-01382	255L	P100	6"	125	4
051131-01383	255L	P80	6"	100	4

## 3M™ Stikit™ Dust-Free Gold “C” Weight Disc Rolls 236U (Non-Staining Fre-Cut™)

3M™ Stikit™ Dust-Free Gold Discs 236U are prepunched with standard hole patterns for dust-free sanding and are designed to be used with 3M™ Stikit™ Dust-Free Disc Pads. 3M™ Stikit™ Dust-Free Gold Discs 236U come in roll form for use with 3M™ Stikit™ Disc Roll Dispenser (PN05450) or 3M™ Stikit™ Light Duty Dispensers (PN05455 for 5" discs and PN05456 for 6" discs) and are available in “C” weight in a full range of grades. Discs have a pressure-sensitive adhesive backing for easy application and removal.



Part Number	Product I.D.	Grade	Size	Discs Per Roll	Rolls Per Case
051144-88707	236U	P500	5"	100	4
051144-88706	236U	P400	5"	100	4
051144-88705	236U	P320	5"	100	4
051144-88704	236U	P240	5"	100	4
051144-88703	236U	P220	5"	100	4
051144-88702	236U	P180	5"	100	4
051144-88701	236U	P150	5"	100	4
051144-88700	236U	P120	5"	100	4
051144-86499	236U	P100	5"	100	4
051144-86498	236U	P80	5"	100	4
051144-86487	236U	P500	6"	100	4
051144-86486	236U	P400	6"	100	4
051144-86485	236U	P320	6"	100	4
051144-86484	236U	P240	6"	100	4
051144-86483	236U	P220	6"	100	4
051144-86482	236U	P180	6"	100	4
051144-86481	236U	P150	6"	100	4
051144-86480	236U	P120	6"	100	4
051144-86479	236U	P100	6"	100	4
051144-86478	236U	P80	6"	100	4

## 3M™ Stikit™ Dust-Free Gold Disc Rolls 216U

3M™ Stikit™ Dust-Free Gold Discs 216U are prepunched with standard hole patterns for dust-free sanding and are designed to be used with 3M™ Stikit™ Dust-Free Disc Pads. 3M™ Stikit™ Dust-Free Gold Discs come in roll form for use with 3M™ Stikit™ Disc Roll Dispenser (PN05450) or 3M™ Stikit™ Light Duty Dispensers (PN05455 for 5" discs and PN05456 for 6" discs) and are available in “A” weight in a full range of grades. Discs have a pressure-sensitive adhesive backing for easy application and removal.



Part Number	Product I.D.	Grade	Size	Discs Per Roll	Rolls Per Case
051131-01619	216U	P400	5"	175	6
051131-01620	216U	P320	5"	175	6
051131-01621	216U	P280	5"	175	6
051131-01622	216U	P240	5"	175	6
051131-01623	216U	P220	5"	175	6
051131-01624	216U	P180	5"	175	6
051131-01625	216U	P150	5"	175	6
051131-01626	216U	P120	5"	125	10
051131-01627	216U	P100	5"	125	10
051131-01628	216U	P80	5"	125	10
051131-01633	216U	P500	6"	175	6
051131-01634	216U	P400	6"	175	6
051131-01635	216U	P320	6"	175	6
051131-01636	216U	P280	6"	175	6
051131-01637	216U	P240	6"	175	6
051131-01638	216U	P220	6"	175	6
051131-01639	216U	P180	6"	175	6
051131-01640	216U	P150	6"	175	6
051131-01641	216U	P120	6"	125	10
051131-01642	216U	P100	6"	125	10
051131-01643	216U	P80	6"	125	10

# 3M™ Stikit™ Dust-Free Abrasives

## 3M™ Green Corps™ Stikit™ Dust-Free Production™ Discs 251U and 246U

3M™ Green Corps™ Stikit™ Dust-Free Production™ Discs 251U and 246U are prepunched with a standard hole pattern for dust-free sanding and are designed to be used with 3M™ Stikit™ Dust-Free Disc Pads. 3M™ Green

Corps™ Stikit™ Dust-Free Discs have a pressure-sensitive adhesive backing for easy application and removal.



Part Number	Product I.D.	Grade	Size	Discs Per Box/Roll	Boxes/Rolls Per Case
051131-01561*	246U	80D	5"	100/Roll	10
051131-01665	251U	40E	5"	100/Box	5
051131-01566*	246U	80D	6"	100/Roll	10
051131-01667	251U	40E	6"	100/Box	5
051131-01668	251U	36E	6"	100/Box	5
051131-01569*	246U	80D	8"	50/Roll	5
051131-01660	251U	40E	8"	50/Box	5
051131-01661	251U	36E	8"	50/Box	5

\* Fre-Cut™ Discs

# 3M™ Stikit™ Dust-Free Abrasive Accessories

## 3M™ Stikit™ Dust-Free Disc Pad

Specially made for use with 3M™ Stikit™ Dust-Free Discs. The vinyl pad face provides good disc adhesion yet allows easy disc removal. Both pads are lightweight, shock resistant and well balanced. Maximum safe operating speed of 7000 RPM for both pads.

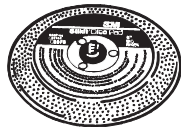

Part Number	For Use With Disc Size	Pads Per Case
051131-45217	5" Diameter	10
051131-45218	6" Diameter	10

## 3M™ Stikit™ Dust-Free Low Profile Disc Pads

3M™ Stikit™ Dust-Free Low Profile Disc Pads are specially designed for 3M™ Stikit™ Dust-Free Discs. The vinyl pad provides good disc adhesion yet allows easy disc removal. Made with a tough, durable plastic hub and durable foam body, pads are lightweight, shock resistant and well-balanced. The low profile design works on all standard dual action type sanders and conversion kits designed for dust-free sanding. Maximum operating speed of 10000 RPM.



Part Number	For Use With Disc Size	Pads Per Case
051131-05655	5" Diameter	10
051131-05656	6" Diameter	10

## 3M™ Stikit™ Dust-Free Low Profile Finishing Disc Pad

3M™ Stikit™ Dust-Free Low Profile Finishing Disc Pads utilize a soft foam construction for fine finish sanding and offer outstanding conformability to contours and curves.

Available in 5" and 6" diameter for use with 5" and 6" 3M™ Stikit™ Dust-Free Discs. Use on random orbital sanders only.



Part Number	For Use With Disc Size	Pads Per Case
051131-05645	5" Diameter	10
051131-05646	6" Diameter	10

## 3M™ Stikit™ Dust-Free Disc Pads for 8" Discs

(Replacement pads for National-Detroit Model 900 and Chicago Pneumatic Model 777 sanders converted for dust-free sanding.)

Our 3M™ Stikit™ Dust-Free 8" pad is specifically designed with a standard hole pattern for dust-free sanding. Pads have a vinyl face which provides excellent adhesion and removal of 3M™ Green Corps™ Stikit™ Dust-Free Discs. Pads are lightweight, durable and well-balanced. Maximum operating speed of 1500 RPM.



Part Number	Description	Pads Per Case
051131-05681	National-Detroit 900	1
051131-05682	Chicago Pneumatic	1

# 3M™ Hookit™ II Dust-Free Sanding Discs

## 3M™ Imperial™ Hookit™ II Dust-Free Discs 334U and 734U

This product earns the 3M Purple color which indicates the latest 3M technology, greatest cost/value and highest quality available. 3M™ Imperial™ Hookit™ II Dust-Free Discs 334U and 734U are high-performance discs designed to cut faster and last longer enabling the user to obtain maximum usage from each disc. The 334U discs (grades P220-P500) are constructed of a high-performance aluminum oxide mineral, and the 734U discs (P80-P180) are constructed of a uniquely blended mineral. Both mineral systems are excellent for use on tough marine gelcoat, paint and primer systems.



Part Number	Product		Size	Discs Per Box	Boxes Per Case
	I.D.	Grade			
051131-00772	334U	P500	6"	50	4
051131-00773	334U	P400	6"	50	4
051131-00774	334U	P360	6"	50	4
051131-00775	334U	P320	6"	50	4
051131-00776	334U	P280	6"	50	4
051131-00778	334U	P220	6"	50	4
051131-00779	734U	P180	6"	50	4
051131-00780	734U	P150	6"	50	4
051131-00781	734U	P120	6"	50	4
051131-00782	734U	P100	6"	50	4
051131-00783	734U	P80	6"	50	4

## 3M™ Hookit™ II Dust-Free Finishing Film Discs 260L

3M™ Hookit™ II Finishing Film Discs 260L are designed for use in scuff sanding before painting, as well as to remove runs, dust, nibs, and excess orange peel from paint and gelcoat prior to compounding. 3M™ Hookit™ II Dust-Free Film Discs 260L are pre-punched with standard hole patterns for dust-free sanding and are designed to be used with 3M™ Hookit™ II Dust-Free Disc Pads. These discs allow for machine sanding versus having to hand sand prior to compounding or using very aggressive compounds (multiple applications of). These discs are individually lined and constructed of a high-performance, aluminum oxide mineral bonded to a smooth film pressure-sensitive adhesive backing. Cuts fast, lasts long, resists loading and leaves a consistent finish.

Part Number	Product		Size	Discs Per Box	Boxes Per Case
	I.D.	Grade			
051131-00751	260L	P1500	5"	50	4
051131-00752	260L	P1200	5"	50	4
051131-00753	260L	P1000	5"	50	4
051131-00754	260L	P800	5"	50	4
051131-00755	260L	P600	5"	50	4
051131-00750	260L	P1500	6"	50	4
051131-00768	260L	P1200	6"	50	4
051131-00769	260L	P1000	6"	50	4
051131-00770	260L	P800	6"	50	4
051131-00771	260L	P600	6"	50	4

## 3M™ Imperial™ Hookit™ II Dust-Free Discs 740I and 745I

This product earns the 3M Purple color which indicates the latest 3M technology, greatest cost/value and highest quality available. 3M™ Imperial™ Hookit™ II Dust-Free Discs 740I and 745I are high-performance discs designed to cut fast and last long, enabling the user to obtain maximum usage from each disc. 3M™ Imperial™ Hookit™ II Dust-Free Discs 740I and 745I are pre-punched with standard hole patterns for dust-free sanding and are designed to be used with 3M™ Hookit™ II Dust-Free Disc Pads. These discs are constructed of a uniquely blended mineral bonded to a tough "E" weight backing. The Hookit™ II attachment system allows for easy application to and removal from the disc pad.



Part Number	Product		Size	Discs Per Box	Boxes Per Case
	I.D.	Grade			
051131-00784	745I	P120E	6"	25	4
051131-00785	745I	P100E	6"	25	4
051131-00786	745I	P80E	6"	25	4
051131-00787	740I	40E	6"	25	4
051131-00788	740I	36E	6"	25	4
051131-00789	745I	P120E	8"	25	4
051131-00790	745I	P100E	8"	25	4
051131-00791	745I	P80E	8"	25	4
051131-00792	740I	40E	8"	25	4
051131-00793	740I	36E	8"	25	4
<b>12 Hole</b>					
051131-00794	745I	P100E	8"	25	4
051131-00795	745I	P80E	8"	25	4
051131-00796	740I	40E	8"	25	4



# 3M™ Hookit™ II Dust-Free Abrasive Accessories

## 3M™ Hookit™ II Dust-Free Disc Pad

This disc pad is specifically made to use with the Hookit™ II Dust-Free Discs. The pad face securely holds the discs yet allows for easy change and reattachment of discs. The disc pad is lightweight, shock-resistant and well balanced. The tough, durable plastic hub and conformable foam body are designed for a maximum operating speed of 10000 RPM.

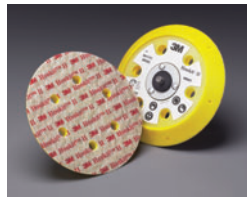

Part Number	For Use with Disc Size/Grade	Pads Per Case
051131- <b>05375</b>	- No Longer Available -	
051131- <b>09352</b>	6" (All Grades) Hard	10

## 3M™ Hookit™ II Dust-Free Low Profile Backup Pad

The 3M™ Hookit™ II Dust-Free Low Profile Backup Pad is specially designed for 3M™ Hookit™ II Dust-Free Discs. The 3M™ Hookit™ II pad face provides good disc adhesion yet allows easy disc removal. Made with a tough, durable plastic hub and durable foam body, pads are lightweight, shock resistant and well balanced. The low profile design works on all standard dual action type sanders and conversion kits designed for dust-free sanding. Maximum operating speeds — 6" = 10000 RPM, 5" = 7000 RPM.



Part Number	Grade	Size	Pads Per Case
051131- <b>05355</b>	D17	5"	10
051131- <b>05356</b>	D17	6"	10

## 3M™ Hookit™ II Dust-Free Low Profile Finishing Disc Pad,

3M™ Hookit™ II Low Profile Finishing Disc Pads utilize a soft foam construction for fine finish sanding and offer outstanding conformability to contours and curves. Available in 5" and 6" diameter for use with 5" and 6" 3M™ Hookit™ II Dust-Free Discs. Use on random orbital sanders only.



Part Number	Grade	Size	Pads Per Case
051131- <b>05345</b>	D17	5"	10
051131- <b>05351</b>	D17	6"	10

## 3M™ Hookit™ II Dust-Free Soft Interface Pads

The 3M™ Hookit™ II Soft Interface Pad is constructed of a soft, durable foam. When used with a standard Hookit™ II backup pad, it increases conformability, allowing the technician to follow contours and get in closer to most edges.



Part Number	For Use with Disc Size	Pads Per Case
051131- <b>05273</b>	5" (600 + finer)	10
051131- <b>05274</b>	6" (600 + finer)	10

## 3M™ Hookit™ II Dust-Free Disc Pad for 8" Discs

(Replacement pads for Hutchins Eliminator, National-Detroit Model 900, Chicago Pneumatic Model 777)



This disc pad is designed to be used with Hookit™ II Dust-Free Discs. The Hookit™ II pad face provides excellent adhesion and easy removal of the abrasive disc. It is lightweight, durable and well balanced. Maximum operating speed of 1500 RPM.

Part Number	For Use on Model	Pads Per Case
051131- <b>05381</b>	National-Detroit 900	1
051131- <b>05382</b>	Chicago Pneumatic 777	1
051131- <b>05380</b>	Hutchins Eliminator	1

# 3M™ Hookit™ Dust-Free Abrasives

## 3M™ Hookit™ Dust-Free Gold Film Discs 255L

3M™ Hookit™ Dust-Free Gold Film Discs 255L incorporate a convenient hook-and-loop attachment system for easy attachment to and removal from the dual action pad face. 3M™ Hookit™ Dust-Free Gold Film Discs 255L are pre-punched with standard hole patterns for dust-free sanding and are designed to be used with 3M™ Hookit™ Dust-Free Disc Pads. The fast cutting, long lasting abrasive construction of the gold film product enables the user to obtain maximum usage of each disc. These discs are pre-punched designed to be used with the 3M™ Hookit™ Dust-Free Low Profile Backup Pads.



Part Number	Product I.D.	Grade	Size	Discs Per Box	Boxes Per Case
051131-01057	255L	P400	5"	100	4
051131-01059	255L	P320	5"	100	4
051131-01060	255L	P280	5"	100	4
051131-01062	255L	P220	5"	100	4
051131-01063	255L	P180	5"	100	4
051131-01064	255L	P150	5"	100	4
051131-01065	255L	P120	5"	100	4
051131-01066	255L	P100	5"	100	4
051131-01067	255L	P80	5"	75	4
051131-01072	255L	P500	6"	100	4
051131-01073	255L	P400	6"	100	4
051131-01074	255L	P360	6"	100	4
051131-01075	255L	P320	6"	100	4
051131-01076	255L	P280	6"	100	4
051131-01077	255L	P240	6"	100	4
051131-01078	255L	P220	6"	100	4
051131-01079	255L	P180	6"	100	4
051131-01080	255L	P150	6"	100	4
051131-01081	255L	P120	6"	100	4
051131-01082	255L	P100	6"	100	4
051131-01083	255L	P80	6"	75	4

## 3M™ Hookit™ Dust-Free Gold Film Discs 255L (Fein® Pattern)

3M™ Hookit™ Dust-Free Gold Film Discs 255L are prepunched with the Fein® Tool eight-hole pattern for dust-free sanding. These discs incorporate a convenient hook-and-loop attachment system for easy attachment to and removal from the pad face. The fast-cutting, long-lasting abrasive construction of the gold film product enables the user to obtain maximum usage of each disc.

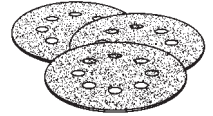

Part Number	Product I.D.	Grade	Size	Discs Per Box	Boxes Per Case
<b>Die #600JX</b>					
051131-01044	255L	P320	6"	100	4
051131-01045	255L	P220	6"	100	4
051131-01046	255L	P150	6"	100	4
051131-01047	255L	P120	6"	100	4
051131-01048	255L	P100	6"	100	4
051131-01049	255L	P80	6"	75	4

Fein® is a registered trademark of Fein Power Tools Inc.  
Note: Available as a KUT item.

## 3M™ Hookit™ Dust-Free Finishing Film Discs 260L

3M™ Hookit™ Dust-Free Finishing Film Discs are designed for use in scuff sanding before painting, as well as to remove runs, dust nibs, and excess orange peel from paint and gelcoat prior to compounding. 3M™ Hookit™ Dust-Free Film Discs 260L are pre-punched with standard hole patterns for dust-free sanding and are designed to be used with 3M™ Hookit™ Dust-Free Disc Pads. These discs allow for machine sanding versus having to hand sand prior to compounding or using very aggressive compounds (multiple applications of). These discs are constructed of a high-performance, aluminum oxide mineral bonding to a smooth film backing. Cuts fast, lasts long, resists loading and leaves a consistent finish.



Part Number	Product I.D.	Grade	Size	Discs Per Box	Boxes Per Case
051131-01053	260L	P1000	5"	100	4
051131-01055	260L	P600	5"	100	4
051131-01050	260L	P1500	6"	100	4
051131-01068	260L	P1200	6"	100	4
051131-01069	260L	P1000	6"	100	4
051131-01070	260L	P800	6"	100	4
051131-01071	260L	P600	6"	100	4

# 3M™ Hookit™ Dust-Free Abrasives

## 3M™ Green Corps™ Hookit™ Regalite™ Dust-Free Discs 750U and 751U

3M™ Green Corps™ Hookit™ Regalite™ Dust-Free Discs are prepunched with a standard hole pattern for dust-free sanding and are designed to be used with our 3M™ Hookit™ Dust-Free Low Profile Backup Pads.



Part Number	Product I.D.	Grade	Size	Discs Per Box	Boxes Per Case
051131-00612	750U	80E	6"	25	5
051131-00615	751U	40E	6"	25	5
051131-00616	751U	36E	6"	25	5
051131-00620	750U	100E	8"	25	5
051131-00621	750U	80E	8"	25	5
051131-00624	751U	40E	8"	25	5
051131-00625	751U	36E	8"	25	5

## 3M™ Green Corps™ Hookit™ Regalite™ Dust-Free Sheets 750U and 751U

3M™ Green Corps™ Hookit™ Regalite™ Dust-Free Sheets are prepunched with a standard hole pattern for dust-free sanding. They are designed to be used with our 3M™ Hookit™ Dust-Free Straightline File Shoe (PN05848) which fits the Rotool and Viking Dustless Sanding Conversion Kits for standard straightline air files. This hole pattern is also designed for use on Hutchins Dust-Free Sanders.



Part Number	Product I.D.	Grade	Size	Sheets Per Box	Boxes Per Case
051131-00638	750U	100E	2-3/4" x 16"	50	5
051131-00639	750U	80E	2-3/4" x 16"	50	5
051131-00642	751U	40E	2-3/4" x 16"	50	5
051131-00643	751U	36E	2-3/4" x 16"	50	5

## 3M™ Green Corps™ Hookit™ Regalite™ Dust-Free Discs 750U and 751U (Fein® Pattern)

3M™ Green Corps™ Hookit™ Regalite™ Dust-Free Discs 750U and 751U are prepunched with the Fein® Tool eight-hole pattern for dust-free sanding. A uniquely blended mineral bonded to a tough "E" weight backing provides a fast-cutting, long-lasting abrasive. The 3M™ Hookit™ attachment system allows easy application to and removal from the disc pad. Excellent for stripping paint or sanding marine fairing compounds.



Part Number	Product I.D.	Grade	Size	Discs Per Box	Boxes Per Case
<b>Die #600JX</b>					
051131-00552	750U	100	6"	25	5
051131-00553	750U	80	6"	25	5
051131-00554	750U	60	6"	25	5
051131-00555	751U	40	6"	25	5
051131-00556	751U	36	6"	25	5

Fein® is a registered trademark of Fein Power Tools Inc.  
Note: Available as a KUT item.

# 3M™ Hookit™ Dust-Free Abrasive Accessories

## 3M™ Hookit™ Dust-Free Disc Pad

This pad is specifically made to use with the 3M™ Hookit™ discs. The pad face securely holds the discs yet allows for easy change and reattachment of discs. The pad is lightweight, shock-resistant and well balanced. The tough, durable plastic hub and conformable foam body are designed for a maximum operating speed of 7000 RPM.



Part Number	For Use With Disc Size	Pads Per Case
051131- <b>82659</b>	5"	10
051131- <b>05876</b>	6"	10

## 3M™ Hookit™ Dust-Free Low Profile Backup Pad

The 3M™ Hookit™ Dust-Free Low Profile Backup Pad is specially designed for 3M™ Hookit™ Dust-Free Discs. The 3M™ Hookit™ pad face provides good disc adhesion yet allows easy disc removal. Made with a tough, durable plastic hub and durable foam body, pads are lightweight, shock resistant and well balanced. The low profile design works on all standard dual action type sanders and conversion kits designed for dust-free sanding. Maximum operating speeds — 6" = 10000 RPM, 5" = 7000 RPM.

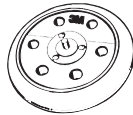

Part Number	For Use With Disc Size	Pads Per Case
051131- <b>05855</b>	5" Diameter	10
051131- <b>05856</b>	6" Diameter	10

## 3M™ Hookit™ Dust-Free Low Profile Backup Pad

(Replacement pad for National-Detroit Model 9600 sander.)



Part Number	For Use With Disc Size	Pads Per Case
051131- <b>05757</b>	– No Longer Available –	

## 3M™ Hookit™ Dust-Free Low Profile Finishing Disc Pad

3M™ Hookit™ Low Profile Finishing Disc Pads utilize a soft foam construction for fine finish sanding and offer outstanding conformability to contours and curves. Available in 5" diameter for use with 5" 3M™ Hookit™ Discs. Use on random orbital sanders only.



Part Number	For Use With Disc Size	Pads Per Case
051144- <b>77856</b>	5" Diameter	10

## 3M™ Hookit™ Soft Interface Pads

These soft interface pads are a very flexible foam which attach to a standard 3M™ Hookit™ disc pad to provide excellent full disc contact, even on curved surfaces.



Part Number	For Use With Disc Size	Pads Per Case
051131- <b>05773</b>	5"	10
051131- <b>05774</b>	6"	10

## 3M™ Hookit™ Dust-Free Disc Pads for 8" Discs

(Replacement Pads for 8" sanders with five or six pad face attachment screws converted for dust-free sanding.) 3M™ Hookit™ Dust-Free 8" pad is specifically designed with a standard hole pattern for dust-free sanding. Pads have a 3M™ Hookit™ face which provides excellent adhesion and removal of 3M™ Green Corps™ Hookit™ Regalite™ Dust-Free Discs. Pads are lightweight, durable and well balanced. Maximum operating speed of 1500 RPM.



Part Number	Description	Pads Per Case
051131- <b>05881</b>	Fits most 8" sanders with 5 pad face attachment screws.	1

## 3M™ Hookit™ Dust-Free Air File Shoe

The 3M™ Hookit™ Dust-Free Air File Shoe has been specially designed for use on all straight air files with 3M™ Green Corps™ Hookit™ Regalite™ Dust-Free File Sheets. The embossed 3M™ Hookit™ face allows for easy attachment and removal of the sheets while eliminating the need for mechanical clips.

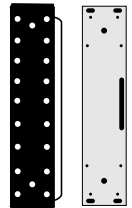

Part Number	Size	Each Per Case
051131- <b>05848</b>	2-3/4" x 16-1/2"	5

# Grinding Discs

## 3M™ Green Corps™ Fibre Discs

The 3M™ Green Corps™ Fibre Disc is an all-purpose grinding disc for any kind of metal or fiberglass grinding. These high-performance green grinding discs are long-lasting and fast cutting for a whole new performance level in metal and fiberglass grinding. Excellent for boat propeller reconditioning.



Part Number	Grade	Size	Discs Per Box	Boxes Per Case
051131-01913	50	5" x 7/8"	20	5
051131-01914	36	5" x 7/8"	20	5
051144-01915	24	5" x 7/8"	20	5
051131-01916	16	5" x 7/8"	20	5
051131-01921	50	7" x 7/8"	20	5
051131-01922	36	7" x 7/8"	20	5
051144-01923	24	7" x 7/8"	20	5
051131-01924	16	7" x 7/8"	20	5
051131-01927	50	9-1/8" x 7/8"	20	5
051131-01928	36	9-1/8" x 7/8"	20	5
051144-01929	24	9-1/8" x 7/8"	20	5
051131-01930	16	9-1/8" x 7/8"	20	5

Part Number	Grade	Size	Discs Per Pack	Packs Per Case
<b>Packaged</b>				
051131-31914	36	5" x 7/8"	2	10
051131-31915	24	5" x 7/8"	2	10
051131-31922	36	7" x 7/8"	2	10
051131-31923	24	7" x 7/8"	2	10

## 3M™ Fibre Discs 501C

3M™ Fibre Discs 501C feature the tough, sharp alumina zirconia (AZ) mineral. Versatile enough to work on a wide variety of metals. Fast cutting, long-lasting and cool running for weld grinding and blending, metal and coatings removal, heavy duty deburring metal finishing.



Part Number	Product I.D.	Grade	Size	Discs Per Box	Boxes Per Case
501111-50409	501C	24	4-1/2" x 7/8"	25	100
501111-50413	501C	36	4-1/2" x 7/8"	25	100
501111-50414	501C	50	4-1/2" x 7/8"	25	100
501111-50415	501C	60	4-1/2" x 7/8"	25	100
501111-50416	501C	80	4-1/2" x 7/8"	25	100
501111-50417	501C	100	4-1/2" x 7/8"	25	100
501111-50419	501C	120	4-1/2" x 7/8"	25	100
501111-50410	501C	24	5" x 7/8"	25	100
501111-50412	501C	36	5" x 7/8"	25	100
501111-50420	501C	50	5" x 7/8"	25	100
501111-50421	501C	60	5" x 7/8"	25	100
501111-50422	501C	80	5" x 7/8"	25	100
501111-50423	501C	100	5" x 7/8"	25	100
501111-50424	501C	120	5" x 7/8"	25	100
501111-50411	501C	24	7" x 7/8"	25	100
501111-50426	501C	36	7" x 7/8"	25	100
501111-50425	501C	50	7" x 7/8"	25	100
501111-50427	501C	60	7" x 7/8"	25	100
501111-50428	501C	80	7" x 7/8"	25	100
501111-50429	501C	100	7" x 7/8"	25	100
501111-50430	501C	120	7" x 7/8"	25	100
501111-50432	501C	24	9-1/8" x 7/8"	25	100
501111-50433	501C	36	9-1/8" x 7/8"	25	100
501111-50434	501C	50	9-1/8" x 7/8"	25	100
501111-50435	501C	80	9-1/8" x 7/8"	25	100

## 3M™ Paint Buster™ Discs 381C

3M™ Paint Buster™ Discs 381C are closed coat and are designed for removing paint, grinding fiberglass and for metal working. Special resin bonding and a sharper, more durable aluminum oxide mineral makes these discs long-lasting and resistant to loading or dulling, especially on acrylic paints. 9-1/8" discs at 4200 RPM — 7" discs at 5500 RPM — 5" at 7650 RPM.



Part Number	Product I.D.	Grade	Size	Discs Per Box	Boxes Per Case
051144-01880		- Suggested Replacement	PN01914	-	-
051144-01881		- Suggested Replacement	PN01915	-	-
051144-01893		- Suggested Replacement	PN01922	-	-
051144-01894		- Suggested Replacement	PN01923	-	-
051144-01906		- Suggested Replacement	PN01928	-	-
051144-01907		- Suggested Replacement	PN01929	-	-

# Grinding Discs

## 3M™ Type C Discs 381C

3M™ Type C Discs 381C are closed coat, aluminum oxide fibre backed discs which are tough as well as flexible. For fiberglass, wood and metal sanding.



Part Number	Product I.D.	Grade	Size	Discs Per Box	Boxes Per Case
051144-01720	381C	120	4" x 5/8"	100	2
051144-01722	381C	80	4" x 5/8"	100	2
051144-01724	381C	50	4" x 5/8"	100	2
051144-01725	381C	36	4" x 5/8"	100	2
051144-81368	381C	24	4" x 5/8"	100	2
051144-20052	381C	120	5" x 7/8"	25	4
051144-20053	381C	100	5" x 7/8"	25	4
051144-20054	381C	80	5" x 7/8"	25	4
051144-01727	381C	60	5" x 7/8"	25	4
051144-01738	381C	120	7" x 7/8"	25	4
051144-01739	381C	100	7" x 7/8"	25	4
051144-01740	381C	80	7" x 7/8"	25	4
051144-81376	381C	50	7" x 7/8"	100	2
051144-01760	381C	120	9-1/8" x 7/8"	25	4
051144-01761	381C	100	9-1/8" x 7/8"	25	4

Part Number	Product I.D.	Grade	Size	Discs Per Pack	Packs Per Case
<b>Packaged</b>					
051131-31722	381C	80	4" x 5/8"	2	10
051131-31724	381C	50	4" x 5/8"	2	10
051131-31725	381C	36	4" x 5/8"	2	10
051131-31368	381C	24	4" x 5/8"	2	10

## 3M™ Type D Discs 280C

3M™ Type D Discs 280C are dependable open coated, heavy duty, aluminum oxide, fibre backed discs. Excellent for fiberglass grinding.



Part Number	Product I.D.	Grade	Size	Discs Per Box	Boxes Per Case
051144-01818	280C	36	5" x 7/8"	25	4
051144-01819	280C	24	5" x 7/8"	25	4
051144-01820	280C	16	5" x 7/8"	25	4
051144-01833	280C	36	7" x 7/8"	25	4
051144-01834	280C	24	7" x 7/8"	25	4
051144-01835	280C	16	7" x 7/8"	25	4
051144-01867	280C	36	9-1/8" x 7/8"	25	4
051144-01868	280C	24	9-1/8" x 7/8"	25	4

## 3M™ Green Corps™ Roloc™ Discs 264F

3M™ Green Corps™ Roloc™ Discs 264F combine the versatility of the Roloc™ disc system with the premium quality of 3M™ Green Corps™ construction. It is a handy quick change tool (PNs 05539 and 05540) for disc grinding which fits any standard 1/4" drill or air tool. A quick 1/2 turn on, 1/2 turn off speeds disc changing and cuts down time. 3M™ Roloc™ discs are color coded. The grit of any disc can be determined by the color of the plastic holding button: grit 50-green, grit 36-brown, grit 24-black.



Part Number	Product I.D.	Grade	Size	Discs Per Box	Boxes Per Case
051131-01396	264F	50	2"	25	10
051131-01397	264F	36	2"	25	10
051131-01398	264F	24	2"	25	10
051131-01406	264F	50	3"	25	10
051131-01407	264F	36	3"	25	10
051131-01408	264F	24	3"	25	10

Part Number	Product I.D.	Grade	Size	Discs Per Pack	Packs Per Case
<b>Packaged</b>					
051131-31407	264F	36	3"	5	10
051131-31408	264F	24	3"	5	10

## 3M™ Regalite™ Polycut™ Roloc™ Discs 777F

3M™ Regalite™ Polycut™ Roloc™ Discs 777F combine the versatility of the 3M™ Roloc™ system with the premium performance of 3M™ Regalite™ Polycut™ construction. Excellent on stainless steel, aluminum and fiberglass.

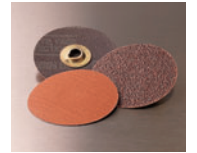

Part Number	Product I.D.	Grade	Size	Discs Per Box	Boxes Per Case
051144-14661	777F	80	2"	50	4
051144-80512	777F	120	2"	50	4
051144-76634	777F	80	3"	50	4
051144-80513	777F	120	3"	50	4

## 3M™ Regalite™ Polycut™ Resin Bond Fibre Grit-Lok™ Discs 785C

The 3M™ Grit-Lok™ Grinding Disc System utilizes a state-of-the-art attachment system which results in fast and easy disc changing. The 3M™ Grit-Lok™ Grinding Disc System also incorporates 3M™ Regalite™ Polycut™ Resin Bond Fibre Grit-Lok™ Discs 785C, a premium performance disc construction, which is ideal for a variety of grinding applications including steel, brass, bronze, aluminum and fiberglass.



Part Number	Product I.D.	Grade	Size	Discs Per Min. Pkg.	Discs Per Case
051144-13884	785C	80	4-1/2"	25	100
051144-13885	785C	60	4-1/2"	25	100
051144-13886	785C	50	4-1/2"	25	100
051144-13888	785C	36	4-1/2"	25	100
051144-13889	785C	24	4-1/2"	25	100

# Grinding Disc Accessories

## 3M™ Disc Pad Hubs and Face Plates

3M's Disc Pad Hubs and Face Plates are light weight, have excellent balance, and low profile for better grinding and finishing control. Full size plates give firm support to disc edge and are tapered to fit the disc shape to minimize flare and wild scratches. This system can result in long term savings in parts and changeover time.

3M Disc Pad Face Plates are color coded by density:

- Red – extra hard: Heavy grinding. (Ribbed only)
- Black – hard: Heavy metal removal, large welds, etc.
- Gray – medium: General purpose grinding and finishing. Normal flexibility.
- White – soft: Finishing operations, flexible, follows contours.

## 3M™ Disc Pad Face Plates – Ribbed

Ribbed face plate results in cooler running disc. Higher pressure on the ribbed sections prolongs disc life when dulling is a problem. Available in 5", 7" and 9" diameter. New red disc is extra hard for heavy grinding.



Part Number	Diameter	Hardness	Max. Oper. RPMs
051144-81732	5"	Extra hard – red	12,000
051144-81733	5"	Hard – black	12,000
051144-81734	5"	Medium – gray	12,000
051144-81735	5"	Soft – white	12,000
051144-80514	7"	Extra hard – red	8,500
051144-80515	7"	Hard – black	8,500
051144-80516	7"	Medium – gray	8,500
051144-80517	7"	Soft – white	8,500
051144-81728	9"	Extra hard – red	6,500
051144-81729	9"	Hard – black	6,500
051144-81730	9"	Medium – gray	6,500
051144-81731	9"	Soft – white	6,500

## 3M™ Disc Pad Face Plates

Replaceable face plates are available in three color-coded densities. Hard-black is for heavy metal removal such as large welds. Medium-gray provides normal flexibility for general purpose grinding and finishing. Soft-white is used in finishing operations and contour grinding. 3M face plates are designed to resist chunking, reduce edge wear and prolong abrasive disc life.



Part Number	Diameter	Hardness	Max. Oper. RPMs
051144-14270	4 1/2"	Hard – black	13,000
051144-13325	4 1/2"	Medium – gray	13,000
051144-45206	5"	Hard – black	12,000
051144-45207	5"	Medium – gray	12,000
051144-45208	5"	Soft – white	12,000
051144-45192	7"	Hard – black	8,500
051144-45193	7"	Medium – gray	8,500
051144-45194	7"	Soft – white	8,500
051144-45195	9"	Hard – black	6,500
051144-45196	9"	Medium – gray	6,500
051144-45197	9"	Soft – white	6,500

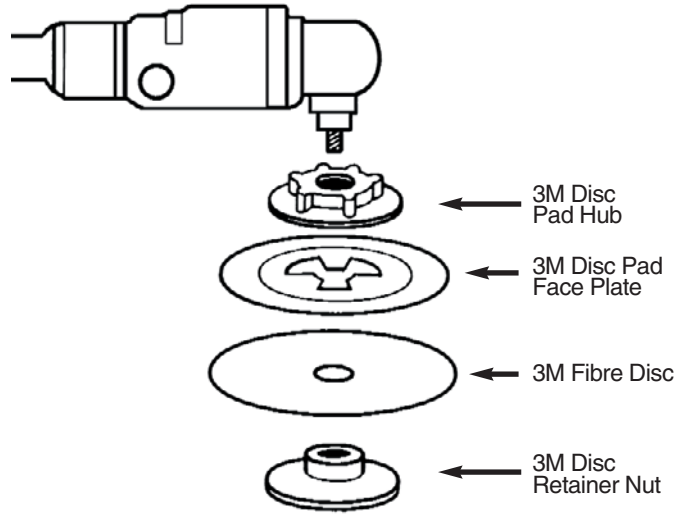

## 3M™ Disc Pad Hubs and Retainer Nut

Durable plastic hubs have 5/8" - 11 threaded metal insert.



Part Number	Diameter
051144-45205	2 1/2" Dia. 5/8"-11 use with all sizes
051144-88743	2 1/2" Disc Pad Hub-Short Shaft Tools
051144-45190	4 1/2" Dia. 5/8"-11 use with sizes 7", 8" & 9"
051131-05632	Retainer Nut; use with sizes 5/8"

## 3M™ Roloc™ Disc Pad Assembly

A hard rubber backup pad for use with 3M™ Roloc™ Discs. Pad assemblies come complete with a 2" x 1/4" steel shaft.

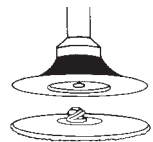

Part Number	For Use With Disc Size	Each Per Case
051144-05539	2" Diameter	10
051144-05540	3" Diameter	10
051131-05541	4" Diameter	10

Part Number	For Use With Disc Size	Packs Per Case
<b>Peggable Package —</b>		
<b>1 Roloc™ Disc Pad Assembly Per Pack</b>		
051131-35540	3" Diameter	5

## 3M™ Grit-Lok™ Disc Hubs

3M™ Grit-Lok™ Disc Hubs provide quick and simple disc changing of 3M™ Regalite™ Polycut™ Resin Bond Fibre Grit-Lok™ Discs. Simply insert disc into hub, rotate the disc a 1/4 turn clockwise and you're ready for grinding.



Part Number	Description	Each Per Case
051144-11824	2-1/2" dia. hub x 5/8" — 11 thread size fits Black & Decker #4247 or #2750, RYOBI #G1150 or G1250, Dynabrade #50378 or #50237, AEG #WS330, WS601, WS750	1
051144-13323	2-1/2" dia. hub x M14 — 2.0 thread size fits Bosch #1347, Metabo #AG550	1

# Cut-Off and Weld Grinding Wheels

## 3M™ General Purpose Cut-Off Wheels

The 3M™ General Purpose Cut-Off Wheel is designed for use in cutting sheet metal, aluminum, stainless steel tubing, propeller shafts, clamps and rusted bolts. For use on utility type cut-off tools. Read all warnings supplied with wheels. Do not use on tool without guards.



Part Number	Size	Wheels Per Case
051131- <b>01987</b>	3" x 1/32" x 3/8"	50
051131- <b>01988</b>	3" x 1/16" x 3/8"	50

## 3M™ Green Corps™ Cut-Off Wheels

The 3M™ Green Corps™ Cut-Off Wheel is a high-performance, long-lasting cut-off wheel for use in cutting sheet metal, aluminum, stainless steel tubing, propeller shafts, clamps and rusted bolts. For use on utility type cut-off tools. Read all warnings supplied with wheels. Do not use on tool without guards.



Part Number	Size	Wheels Per Pack	Packs Per Case
<b>Packaged</b>			
051131- <b>01989</b>	3" x 1/32" x 3/8"	5	10
051131- <b>31989</b>	– No Longer Available –		
051131- <b>01990</b>	3" x 1/16" x 3/8"	5	10
051131- <b>31990</b>	3" x 1/16" x 3/8" Peggable	1	10

Part Number	Size	Wheels Per Case
<b>Bulk</b>		
051131- <b>82238</b>	3" x 1/32" x 1/4"	50
051131- <b>01994</b>	4" x 1/32" x 3/8"	50

## 3M™ Green Corps™ Reinforced Weld Grinding Wheel

The 3M™ Green Corps™ Reinforced Weld Grinding Wheel is ideal for cutting spot welds and grinding in hard-to-reach places. Read all warnings supplied with wheels. Do not use on tool without guards.



Part Number	Size	Wheels Per Pack	Packs Per Case
051131- <b>01991</b>	3" x 3/16" x 3/8"	5	10



# Type 27 Depressed Center Grinding Wheels

## 3M™ Green Corps™ Flexible Grinding Discs

These 1/8" thick grinding wheels contain 3M patented Cubitron™ for fast cut, durability and a consistent finish on all metals. Thinner design gives wheels more flexibility. Smooth operation with minimal vibration. For weld removal and heavy deburring on steel, iron, stainless steel and aluminum. Discs are 1/8" thick with 7/8" shaft. MUST BE USED ON A TOOL WITH A GUARD.

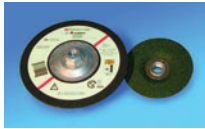

## 3M™ Marine General Purpose Depressed Center Grinding Wheels — Type 27

Type 27 1/4" thick depressed center wheels are an excellent economical solution for general purpose grinding applications on steel. MUST BE USED ON A TOOL WITH A GUARD.



Part Number	Grit	Size	Each Per Box	Boxes Per Case
051111-50444	80	4-1/2"	20	10
051111-50443	60	4-1/2"	20	10
051111-50442	46	4-1/2"	20	10
051111-50440	36	4-1/2"	20	10
051111-50448	80	7"	20	5
051111-50447	60	7"	20	5
051111-50446	46	7"	20	5
051111-50445	36	7"	20	5

Part Number	Size	Wheels Per Box	Boxes Per Case
051131-01970	4 1/2" x 1/4" x 7/8"	25	1
051131-01971	4 1/2" x 1/4" x 5/8-11"	10	1
051131-01972	5" x 1/4" x 7/8"	25	1
051131-01973	5" x 1/4" x 5/8-11"	10	1
051131-01974	7" x 1/4" x 7/8"	25	1
051131-01975	7" x 1/4" x 5/8-11"	10	1

Part Number	Description	Each Per Box	Boxes Per Case
<b>Adapter Nuts</b>			
051144-88765	5/8"-11 Thread	2	5
051144-88763	– No Longer Available –		
051144-88764	– No Longer Available –		
051144-88766	– No Longer Available –		

<b>3M Disc Holder T-27 Kit</b>			
051144-88769	T-27 Kit (includes plate, nut, spacers, & wrench)	1	1

<b>Plastic Backup Plates</b>			
051111-51045	7" Diameter	5	20
051111-51046	4-1/2" Diameter	5	20

## Green Corps™ Flexible Grinding Wheel Attachment System

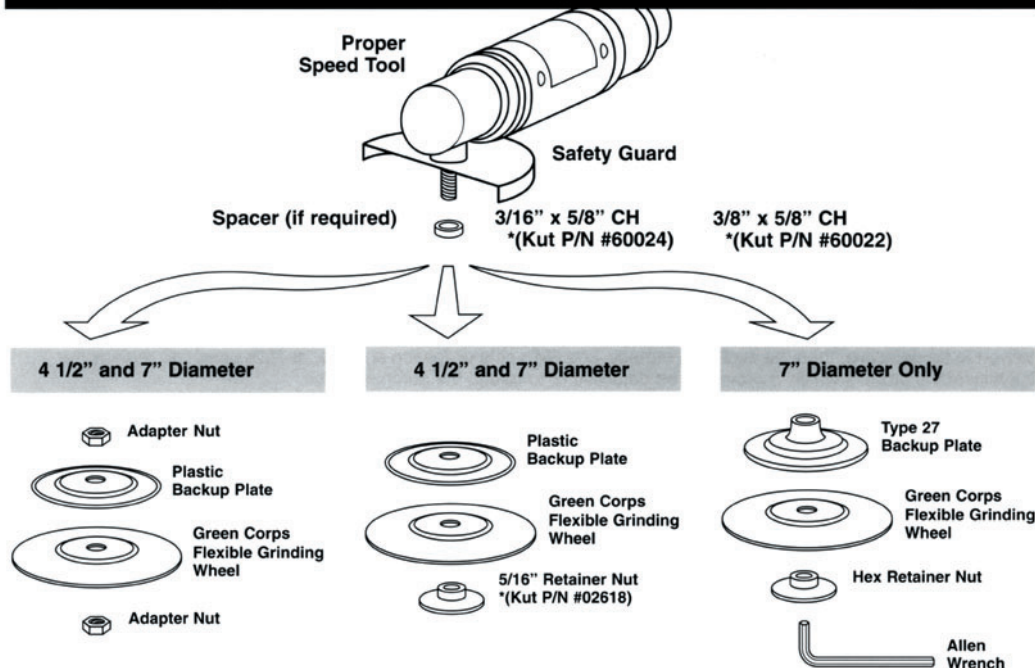

# Scotch-Brite™ Hand Pads

## Scotch-Brite™ Heavy Duty Pad — Tan

A non-woven, three-dimensional product to be used on the following applications; varnish stripping, bottom paint scuffing and stripping, rust removal and heavy clean-up.



Part Number	Size	Pads Per Box	Boxes Per Case
7440	6" x 9"	10	4

## Scotch-Brite™ Light Duty Pad — White

For light scouring, including rust removal. Conformable so hard-to-reach, contoured surfaces are easy to reach. Open web construction makes pads easily cleaned for repeated work.



Part Number	Size	Pads Per Box	Boxes Per Case
051131-07445	6" x 9"	20	3

## Scotch-Brite™ Blending Hand Pad — Gray

A non-woven, three-dimensional product to be used on the following applications: blending/finishing of aluminum, wood highlighting and light paint removal. Blending hand pads are designed to replace steel wool and wire screens.



Part Number	Size	Pads Per Box	Boxes Per Case
7446	6" x 9"	10	4

## Scotch-Brite™ General Purpose Pad — Maroon

For scuffing before applying paint and paint primers. Also may be used in cleaning upholstery and chrome. Can be rinsed and used over and over again.



Part Number	Size	Pads Per Box	Boxes Per Case
051131-07447	6" x 9"	20	3

## Scotch-Brite™ Ultra Fine Pad — Gray

Used to finish sand scratches after using 3M™ Wetordry™ abrasives in the 360A grit range. Reusable.



Part Number	Size	Pads Per Box	Boxes Per Case
051131-07448	6" x 9"	20	3

## Scotch-Brite™ Multi-Flex Abrasive Sheet Rolls

Use PN07521 for scuffing before applying paint and paint primers. Also may be used in cleaning upholstery and chrome. A thin, ultra-conformable extra sharp and economical Scotch-Brite™ Sheet. Use for quick scuffing irregular surfaces. Non-leveling, reusable, use wet or dry. Use PN07522 on the following applications: blending/ finishing of aluminum, wood highlighting and light paint removal. Designed to replace steel wool and wire screens. Extra sharp for fast surface preparation. Non-leveling, reusable, use wet or dry.



Part Number	Sheet Size/Grade	Sheets Per Roll	Rolls Per Case
051131-07521	4" x 8" A-VFN General Purpose, Maroon/Purple	60	4
051131-07522	4" x 8" S-UFN Ultra-Fine Gray	60	4

## Scotch-Brite™ General Purpose and Ultra Fine Scuff Sponges

Scotch-Brite™ General Purpose and Ultra Fine Scuff Sponges are three-dimensional non-woven material laminated to a cellulose sponge material. These sponges are ideal for scuffing/cleaning a variety of marine surfaces. Sponges may be used wet or dry. Hand-held size offers convenience, comfort and reduces waste. Produces the same finish as the 07447 (Maroon) and 07448 (Gray) Scotch-Brite™ Hand Pads.



Part Number	Description	Color	Sponges Per Bag	Sponges Per Case
051131-07441	General Purpose Sponge	Maroon	10	30
051131-07442	Ultra Fine Sponge	Gray	10	30
051131-07439	Clean & Prep Sponge	White	10	30

## Scotch-Brite™ Cleansing Sponge — No. 63

This convenient two-sided light cleansing tool is ideal for use on stainless steel, plexiglass and plastic surfaces. It won't scratch most surfaces. Scotch-Brite™ side for cleansing action backed by an absorbent cellulose sponge on the other side for wiping spills.



Part Number	Size	Sponges Per Case
048011-08251	5-5/8" x 3-1/2"	20

# Scotch-Brite™ Hand Pads

## Scotch-Brite™ Scrubbing Sponge — No. 74

Here's a dual-action cleaning tool for dirty surfaces. It's a scouring pad on one side — scrubs and cleans walls, tables and countertops. The cellulose sponge on the other side quickly wipes up spills and messes. Handy and versatile.

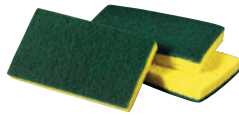

Part Number	Size	Sponges Per Case
048011-20688	6-1/4" x 3-1/2"	20

## Scotch-Brite™ Power Pad — No. 2000

Scours up to 4 times faster than conventional products. Scratches surfaces up to 8 times less than other medium/heavy-duty products. Unique bow-tie shape.



Part Number	Size	Pads Per Case
048011-23162	5.5" x 3.9"	20

## Scotch-Brite™ Flexible Scrubber — No. 85

Patented, non-metallic web is thin and flexible enough to scrunch into a ball and scour tight corners. Aggressive scouring power with NO metal splinters. Won't scratch stainless steel or aluminum surfaces.



Part Number	Size	Each Per Box	Boxes Per Case
048011-26015	6" x 9"	40	3

## Scotch-Brite™ Power Pad Sponge — No. 3000

Two cleaning tools in one — Scotch-Brite™ Power Pad combined with a sponge. Scratches surfaces up to 8 times less than other medium duty/heavy duty products.

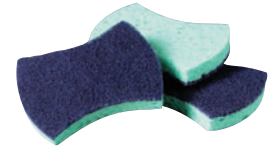

Part Number	Size	Sponges Per Case
048011-23163	2.8" x 4.5" x 0.6"	20

## Scotch-Brite™ General Purpose Commercial Scouring Pad — No. 96

It's the original nylon scouring pad and a performance pacesetter. It replaces steel wool and metal sponges, and won't leave metal splinters in hands. Long lasting, non-rusting and resilient.



Part Number	Size	Pads Per Box	Boxes Per Case
048011-08293	6" x 9"	20	3

## 3M™ Soft Scour!™ Sponge — No. 9489

This sponge combines no-scratching scrubbing and moisture pick-up all in one. One side scours and the other side wipes up spills or carries cleaning solution to the work surface.



Part Number	Size	Pads Per Bag	Bags Per Case
048011-09489	3-1/2" x 5"	10	4

## Scotch-Brite™ General Purpose Scrubbing Pad — No. 9650

Thicker, hand-size version of Scotch-Brite™ General Purpose Scour Pad No. 96. The convenient size eliminates the need to cut or fold the pad.

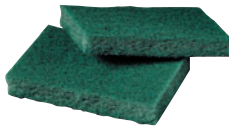

Part Number	Size	Pads Per Case
048011-15027	3.5" x 5"	60

# Scotch-Brite™ Cleaning and Stripping Products

## Scotch-Brite™ General Purpose and Ultra Fine Scuffing Wheels Roloc™+

These are constructed of a durable three-dimensional non-woven material. Both products are flexible and ideal for machine scuffing/ cleaning of hard to reach areas. The 3M™ Roloc™+ Holder (PN07500) allows for easy changeover of discs.



Part Number	Size	Wheels Per Box	Boxes Per Case
051131-07443	4" x 1-1/8" Gen. Purpose	10	1
051131-07444	4" x 1-1/8" Ultra Fine	10	1

## Scotch-Brite™ Clean 'n Strip™ XT Discs

This product earns the 3M Purple color which indicates the latest 3M technology, greatest cost/value and highest quality available. 3M™ Scotch-Brite™ Clean 'n Strip™ XT Discs have an open web construction for cool running with excellent resistance to loading and smearing. Faster cutting than wire brushes and wheels with no rust or surface contamination from metal residue. These discs are the perfect alternative to wire brushes for removing weld discoloration, scale, rust, paint, coatings, gasket and sealing compounds, adhesives and marine algae.

Part Number	Size	MOS (RPMs)	Discs Per Case
048011-27657	4" x 1/4"	6,000	25
048011-27658	8" x 1/2"	3,000	15
048011-27663	4" x 1/2"	6,000	25
048011-25790	6" x 1/2"	4,000	15

## Scotch-Brite™ Clean 'n Strip™ Roloc™+ Discs

Scotch-Brite™ Clean 'n Strip™ Roloc™+ Discs are constructed of a three-dimensional, durable web. These discs are the perfect alternative to wire brushes for removing paint, rust, cleaning welds, drip rail moldings and light grinding/ sanding in hard-to-reach areas. The 3M™ Roloc™+ Holder (PN07500) allows for easy changeover of discs.



Part Number	Size	Discs Per Case
051131-07466	4" x 1/2"	10

## Scotch-Brite™ Roloc™+ Rivet Cleaning Disc

Scotch-Brite™ Roloc™+ Rivet Cleaning Discs are constructed of a three dimensional, non-woven material designed to sand and clean around rivets. These discs are aggressive, yet highly conformable. Discs are used in conjunction with 3M™ Roloc™+ Holder (PN07500).



Part Number	Size	Discs Per Case
051131-07410	4" x 1-1/4"	10

# Stripe Removal Discs

## Scotch-Brite™ Large Area Stripe Removal (LASR) Disc Assembly

This is a 8" diameter, 16 layer version of the existing 3M™ Molding Adhesive and Stripe Removal Disc (PNs 07501, 07502). The LASR disc assembly quickly removes vinyl stripes and graphics and their adhesive without damaging gelcoat or marine paint. This assembly is designed to be used with a variable speed buffer with a 1,500-3,000 RPM speed range. Attaching a Scotch-Brite™ LASR Adaptor (PN07519) is all that is necessary to convert your 5/8"-11 shaft to accommodate the LASR Disc Assembly. An approved tool is the Black and Decker Buffmaster #6138.



Part Number	Size	Each Per Case
051131-07517	8" dia. x 5/8"	1

## Scotch-Brite™ Large Area Stripe Removal (LASR) Adaptor

This is an adaptor to fit the Scotch-Brite™ Large Area Stripe Removal (LASR) Disc Assembly (PN07517) to the tool with a 5/8-11 shaft.

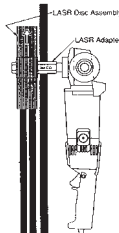

Part Number	Each Per Case
051131-07519	1

## Scotch-Brite™ Molding Adhesive and Stripe Removal Disc Roloc™+

Scotch-Brite™ Molding Adhesive and Stripe Removal Disc is a vinyl, non-abrasive material designed to remove vinyl stripes, numbers, letters and graphics from gelcoat and painted marine surfaces without damaging the finish. Required 4000 RPM tool.



Part Number	Size	Billing Units Per Case
051131-07501	4" x 3/8"	5
051131-07502	6" x 3/8"	5

## 3M™ Roloc™+ Holder

A durable plastic holder for use with all Roloc+ products including 1/4" steel shank allows easy use to portable tools.



Part Number	Size	Billing Units Per Case
051131-07500	1" Dia. x 1/4" Shank	1

# Scotch-Brite™ Surface Conditioning Discs

## Scotch-Brite™ RS Surface Conditioning Discs

Scotch-Brite™ RS Surface Conditioning Discs are 3M's fastest cutting surface conditioning discs. This product earns the 3M Purple color which indicates the latest 3M technology, greatest cost/value and highest quality available. They are the only family of abrasives to combine the conditioning quality of 3M non-woven technology with the aggressive cut of 3M patented Cubitron™ abrasive grain. The Scotch-Brite™ RS Surface Conditioning Discs provide high quality, uniform, burr-free finishes and can raise production and quality standards for blending, deburring and finishing of any metal. They are available in Roloc™ or Hook-and-Loop attachment systems.

Part Number	Description	Size	Grade	MOS	Quantity Per Case
<b>Roloc Discs</b>					
048011-29211	Scotch-Brite™ Roloc™ RS Disc	2"	Coarse	25,000	200
048011-29212	Scotch-Brite™ Roloc™ RS Disc	2"	Medium	25,000	200
048011-29213	Scotch-Brite™ Roloc™ RS Disc	3"	Coarse	18,000	100
048011-29214	Scotch-Brite™ Roloc™ RS Disc	3"	Medium	18,000	100

### Hook-and-Loop Accessories

048011-29217	Scotch-Brite™ RS Disc	4-1/2"	Coarse	13,000	50
048011-29218	Scotch-Brite™ RS Disc	4-1/2"	Medium	13,000	50
048011-29219	Scotch-Brite™ RS Disc	5"	Coarse	10,000	50
048011-29220	Scotch-Brite™ RS Disc	5"	Medium	10,000	50
048011-29221	Scotch-Brite™ RS Disc	7"	Coarse	6,000	25
048011-29222	Scotch-Brite™ RS Disc	7"	Medium	6,000	25

## Scotch-Brite™ RS Surface Conditioning Accessories



Part Number	Description	Size	Grade	MOS	Quantity Per Case
<b>Roloc™ TR Disc Pads</b>					
051144-45091	3M™ Roloc™ TR Disc Pads	3"	Hard	20,000	5
051144-45092	3M™ Roloc™ TR Disc Pads	3"	Medium	18,000	5
051144-45095	3M™ Roloc™ TR Disc Pads	2"	Medium	25,000	5
051144-45096	3M™ Roloc™ TR Disc Pads	2"	Hard	25,000	5

## Scotch-Brite™ RS Surface Conditioning Accessories (continued)



Part Number	Description	Size	MOS	Quantity Per Case
<b>Hook-and-Loop Accessories</b>				
051144-85097	3M™ Roloc™ TS Mandrel*	1/4" x 2"	—	5
048011-05680	3M™ Disc Pad Holder 5/8" - 11 Female Hub Shank	5"	10,000	1
048011-09450	3M™ Disc Pad Holder 5/8" - 11 Female Hub Shank	7"	6,000	1
048011-14111	3M™ Disc Pad Holder 5/8" - 11 Female Hub Shank	4-1/2"	13,000	1

## Scotch-Brite™ Roloc™ Surface Conditioning Discs

Scotch-Brite™ Roloc™ Surface Conditioning Discs combined with the quick "1/2 turn on, 1/2 turn off" 3M™ Roloc™ disc fastening system.

The 3M™ Roloc™ disc fastening system offers ease of disc centering and is used in conjunction with 3M™ Roloc™ Disc Pad Assemblies, 05539 (for 2"), 05540 (for 3") and 05541 (for 4"). The coarse grade (brown) equates with a coated abrasive grit of 80 to 100, medium (maroon) 100 to 120 grit, very fine (blue) 220-320, super fine (gray) 320-600. The 3M™ Roloc™ System requires use of the 3M™ Roloc™+ Holder (PN07500).



Part Number	Size & Grade	Discs Per Box	Boxes Per Case
051131-07480	2" Coarse	25	4
051131-07481	2" Medium	25	4
051131-07515	2" Very Fine	25	4
051131-07516	2" Super Fine	25	4
051131-07485	3" Coarse	25	4
051131-07486	3" Medium	25	4
051131-07513	3" Very Fine	25	4
051131-07514	3" Super Fine	25	4
051131-07482	4" Coarse	10	10
051131-07483	4" Medium	10	10
051131-07511	4" Very Fine	10	10
051131-07512	4" Super Fine	10	10

## 3M™ Roloc™ Disc Pad Assembly

This disc pad assembly comes complete with a 2" steel shaft and adaptor. The hard rubber backup pad provides firm support for Scotch-Brite™ Roloc™ Surface Conditioning Discs (PNs 07480-07514) and 3M™ Roloc™ Bristle Discs (PNs 18698-18737).



Part Number	Size	Hardness	Quantity Per Case
051144-45102	1/4"	Threaded Shaft	1
051144-45101	1"	Medium	5
051144-05539	2"	Medium	10
051144-05540	3"	Medium	10

# Scotch-Brite™ Surface Conditioning Discs

## Scotch-Brite™ Surface Conditioning Discs

The unique open web construction of these discs delivers a uniform, consistent finish because it resists the loading and heat buildup that normally affect disc performance; they also work fast and reduce labor and material cost. These discs are designed to be used with the Scotch-Brite™ Disc Holder (PNs 07492-07494 and 09450-09451) and attach safely and securely through the use of the 3M™ Scotchmate™ Dual Lock™ Fastening System. The larger and coarser discs have applications for coating removal and surface preparation of boat hulls. The smaller discs are used in cleaning and surface upgrading of boat propellers, as well as gasket removal. The Coarse grade (brown) equates with a coated abrasive grit of 80 to 100, Medium (maroon) 100 to 120 grit, Very Fine (blue) 220-320, Super Fine (gray) 320-600.



Part Number	Size & Grade	Discs Per Box	Boxes Per Case
048011-00752	8" Coarse	—	20
048011-00670	8" Medium	—	25
048011-04306	8" Very Fine	—	20
048011-00751	7" Coarse	—	25
048011-00645	7" Medium	—	25
048011-04305	7" Very Fine	—	20
048011-07450	4" Coarse	25	100
048011-07451	4" Medium	25	100
051131-07504	4" Very Fine	10	4
051131-07505	4" Super Fine	10	4
051131-07455	3" Coarse	25	100
051131-07456	3" Medium	25	100
051131-07506	3" Very Fine	25	4
051131-07507	3" Super Fine	25	4
051131-07453	2" Coarse	25	100
051131-07457	2" Medium	25	100
051131-07508	2" Very Fine	25	4
051131-07509	2" Super Fine	25	4

## Scotch-Brite™ Surface Conditioning Disc Pad

This hook-and-loop disc pad connects quickly to any power tool while holding Scotch-Brite™ Surface Conditioning Discs (PNs 00645-00752 and 07450-07509) securely and safely through the use of 3M™ Scotchmate™ Dual-Lock™ Fastening System.



Part Number	Size	Pads Per Case
048011-09451	For 8 in. Discs	1
048011-09450	For 7 in. Discs	1
048011-07492	For 4 in. Discs	5
051131-07493	For 3 in. Discs	10
048011-07494	For 2 in. Discs	10

## 3M™ Contact Disc Pad Holder — No. 947, 7"

This disc pad holder may be used with 3M™ 7" and 8" Surface Conditioning Discs (PNs 00645, 00670, 00751, and 00752) for use in various scuffing applications. 3M™ No. 947 Disc Pad Holder features a flexible edge which enables the pad to better conform to contours of boat hulls. This disc pad holder fits 5/8" shaft tools; the maximum operating speed is 6000 RPM.

Part Number	Each Per Case
051144-13627	1

## Scotch-Brite™ General Purpose and Ultra-Fine Scuffing Discs

Scotch-Brite™ General Purpose Scuffing Disc (Maroon) and Scotch-Brite™ Ultra-Fine Scuffing Disc (Gray) are constructed of a durable, three-dimensional, non-woven Scotch-Brite™ web. These 6" discs are designed to be used in conjunction with a 3M™ Hookit™ Disc Pad for 6" discs (PN05776 or 05747) on a random orbital sander. These discs offer a quicker, more efficient method of machine scuffing marine finishes versus doing it by hand.



Part Number	Size/Grade	Color	Discs Per Box	Boxes Per Case
051131-07467	6" General Purpose	Maroon	10	4
051131-07468	6" Ultra-Fine	Gray	10	4

# 3M™ Bristle Discs and Brushes

## 3M™ Roloc™ Bristle Discs

The 3M™ Roloc™ Bristle Disc is a molded abrasive bristle product designed to conform to the workpiece in numerous surface conditioning applications. Much safer to use than conventional wire brushes the discs use the quick "1/2 turn on, 1/2 turn off" Roloc™ fastening system for maximum convenience. In addition, the 3M™ Roloc™ Bristle Disc works well in applications where loading is a problem, replacing wire brushes, surface conditioning discs, and coated abrasive discs. The bristle design and 3-dimensional abrasive enable the bristle disc to remove coatings, sealant, and adhesives quickly, leaving a clean surface ready for subsequent operations. The high Maximum Operating Speed (MOS) of the bristle disc makes it compatible with right angle die grinders. Use in conjunction with the 3M™ Roloc™ Disc Pad Assembly (PNs 05539-05540 and 45101-45102). (1" MOS = 30000 RPM, 2" MOS = 25000 RPM, 3" MOS = 18000 RPM). The 3M™ Roloc™ System requires use of the 3M™ Roloc™+ Holder (PN07500).



Part Number	Size	Grade	Color	Discs Per Box	Discs Per Case
048011-18698	1"	50	Green	20	80
048011-18706	1"	80	Yellow	20	80
048011-18710	1"	120	White	20	80
048011-18730	2"	50	Green	10	40
048011-18732	2"	80	Yellow	10	40
048011-18733	2"	120	White	10	40
048011-18734	3"	50	Green	10	40
048011-18736	3"	80	Yellow	10	40
048011-18737	3"	120	White	10	40

## 3M™ Roloc™ Disc Pad Assembly

This disc pad assembly comes complete with a 2" steel shaft and adaptor. The hard rubber backup pad provides firm support for Scotch-Brite™ Roloc™ Surface Conditioning Discs (PNs 07480-07514) and 3M™ Roloc™ Bristle Discs (PNs 18698-18737).



Part Number	Size	Hardness	Each Per Case
051144-45102	1/4"	Threaded Shaft	1
051144-45101	1"	Medium	5
051144-05539	2"	Medium	10
051144-05540	3"	Medium	10

## 3M™ Radial Bristle Brushes

3M™ Radial Bristle Brushes bring superior cleaning to a wide variety of surface areas. The 6" radial bristle brush works on most bench motors in place of wire brushes for general maintenance and production. Tough, flexible products provide a faster cut and more uniform finish.



Part Number	Size	Grade	Color	Brushes Per Box	Brushes Per Case
048011-27603	6" Brush	36	Dk Brown	1	5
048011-27605	6" Brush	50	Green	1	5
048011-27606	6" Brush	80	Yellow	1	5

## 3M™ Roloc™ Bristle Disc Introductory Packs

Convenient introductory packs of 2" and 3" 3M™ Roloc™ Bristle Discs as well as assortments of 2" and 3" 3M™ Roloc™ products including 777F 3M™ Roloc™ Discs, Surface Conditioning and SE Surface Conditioning Discs, Unitized Wheels, 3M™ Roloc™ Bristle Discs, and 3M™ Roloc™ Disc Pad Holder.



Part Number	Intro Pack Number	Contents	Packs Per Case
048011-18696	982BS	(2) ea. 3M™ Roloc™ Bristle Disc, 2" x 5/8" T 50X, 80X, 120X (1) ea. 3M™ Roloc™ Disc Pad Holder, 2" Hard	5
048011-18697	983BS	(2) ea. 3M™ Roloc™ Bristle Disc, 3" x 5/8" T 50X, 80X, 120X (1) ea. 3M™ Roloc™ Disc Pad Holder, 3" Hard	5
048011-18694	982RS	(3) ea. 3M 777F 3M™ Roloc™ Disc, 2" - 60YF, 80YF, 120YF (2) ea. 3M™ Roloc™ Surface Conditioning Disc, 2" - ACRS, AMED, AVFN, SSFN(2) ea. 3M™ Roloc™ SE Surface Conditioning Disc, 2" - ACRS (1) ea. 3M™ Roloc™ EXL Unitized Wheels, 2" - 2SFIN, 6AMED, 8ACRS (2) ea. 3M™ Roloc™ Bristle Disc, 2" x 5/8" T - 50X, 80X, 120X (1) ea. 3M™ Roloc™ Disc Pad Holder, 2" Hard	5
048011-18695	983RS	(3) ea. 3M 777F 3M™ Roloc™ Disc, 3" - 60YF, 80YF, 120YF (2) ea. 3M™ Roloc™ Surface Conditioning Disc, 3" - ACRS, AMED, AVFN, SSFN (2) ea. 3M™ Roloc™ SE Surface Conditioning Disc, 3" - ACRS (1) ea. 3M™ Roloc™ EXL Unitized Wheels, 3" - 2SFIN, 6AMED, 8ACRS (2) ea. 3M™ Roloc™ Bristle Disc, 3" x 5/8" T - 50X, 80X, 120X (1) ea. 3M™ Roloc™ Disc Pad Holder, 3" Hard	5

## 3M™ Radial Bristle Discs

3M™ Radial Bristle Discs, 1" and 9/16" are meant for very small jobs. The 9/16" is specifically for polishing in small, tight places where a mirror-like finish is desired. They are very flexible for deburring, cleaning, and/or finishing intricate or tiny areas. The 1" disc is for small areas with heavy duty requirements. Can be used to clean machine marks on soft and hard metals for precision parts or hard-to-reach areas. Satin finish for watch cases and other small metal products. With these discs, you can automate many previous manual operations, and replace chemicals.



Part Number	Size	Grade	Color	Discs Per Box	Discs Per Case
048011-27610	1" Disc	36	Dk Brown	24	96
048011-27611	1" Disc	50	Green	24	96
048011-27612	1" Disc	80	Yellow	24	96
048011-27613	1" Disc	120	White	24	96
048011-27614	9/16" Disc	120	White	48	192
048011-27615	9/16" Disc	P220	Red	48	192
048011-27616	9/16" Disc	P400	Blue	48	192
048011-27617	9/16" Disc	Pumice	Pink	48	192
048011-27618	9/16" Disc	Polish I	Lt Green	48	192
048011-27619	9/16" Disc	Polish II	Peach	48	192

# Retail Packaged Abrasive Products

## 3M™ Wood, Metal, Plastic Surfaces (Production™ Paper Sheets)

The choice of do-it-yourselfers for sanding a wide variety of materials. It is made of aluminum oxide, an extremely tough and durable synthetic mineral.



Part Number	Grade	Size	Sheets Per Pack	Packs Per Case
051144-09001	Fine 150	9" x 11"	5	20
051144-09002	Medium 100	9" x 11"	5	20
051144-09003	Coarse 60	9" x 11"	4	20
051144-09004	Extra Coarse 40	9" x 11"	3	20
051144-09005	Assorted	9" x 11"	5	20

## 3M™ Varnish and Paint Wet or Dry Finishing (Wetordry™ Tri-M-ite™ Paper Sheets)

This 3M™ sandpaper is ideal for wet sanding between coats of varnish, paint and other finishes. It is made with silicon carbide, a sharp synthetic mineral that cuts fast and is satin smooth.



Part Number	Grade	Size	Sheets Per Pack	Packs Per Case
051144-09084	Ultra Fine 600	9" x 11"	5	20
051144-09085	Super Fine 400	9" x 11"	5	20
051144-09086	Extra Fine 320	9" x 11"	5	20
051144-09087	Very Fine 240	9" x 11"	5	20
051144-09088	Assorted*	9" x 11"	5	20

\*Contains 1 sheet VF and 2 sheets SF and EF

## 3M™ Stripping Pad

The 3M™ Stripping Pad is designed for use with chemical strippers in removing paint and varnish. Made from a tough, non-woven synthetic material that won't rust or splinter like steel wool.



Part Number	Pads Per Case
051144-07413	10

## 3M™ Metal Finishing Pad

The 3M™ Metal Finishing Pad is designed for removing light rust; cleaning and brightening metal. Made from a tough, non-woven synthetic material that won't rust or splinter like steel wool.



Part Number	Pads Per Case
051144-07414	10

## 3M™ Wood Finishing Pad

The 3M™ Wood Finishing Pad is designed for smoothing bare wood, rubbing in furniture oils and denibbing between coats of stain, sealer or varnish. Made from a tough, non-woven synthetic material that won't rust or splinter like steel wool.



Part Number	Pads Per Case
051144-07415	10

## 3M™ Flexible Sanding Sponge

A urethane foam sponge for sanding contoured and hard-to-reach surfaces. Has tough aluminum oxide abrasive on all four sides. Reusable. Rinse clean, squeeze and use again. One sponge per pack. Sponges are 3-3/4" x 2-5/8" x 1".



Part Number	Grade	Packs Per Case
051131-50038	Fine/Medium	24
051131-50037	Medium/Coarse	24

## 3M™ Rubber Sanding Block

Makes hand sanding easy and fast on flat and curved surfaces. Made of pliable rubber for a comfortable grip and better control. For use with regular sandpaper.



Part Number	Blocks Per Case
021200-09292	10

## 3M™ All-Purpose Tack Cloth

Safely removes dirt, lint, dust and sanding particles from fiberglass, metal, plastic, wood and wallboard surfaces prior to painting or staining. Excellent for a number of marine applications.



Part Number	Size	Cloths Per Pack	Packs Per Case
051144-03192	16" x 20"	1	40



# Retail Packaged Abrasive Products

## 3M™ Power Sanding Products

### 3M™ Adhesive Backed Sandpaper Discs — 5"

3M™ Adhesive Backed Discs have a pressure-sensitive backing that requires no holding or fastening devices. These discs last longer and won't tear like ordinary discs because the disc sticks to the entire pad surface.



Part Number	Grade	Discs Per Pack	Packs Per Case
051144-09170	Fine	5	20
051144-09171	Medium	5	20
051144-09172	Coarse	4	20

### 3M™ Adhesive Backed Sanding Kit — 5" Disc

Kit contains three Adhesive Backed Discs (1 each fine, medium, coarse) plus one 5" Adhesive Backed Disc Pad.



Part Number	Kits Per Case
051144-09176	10

### 3M™ 5" Hookit™ Discs/Kit

Use for sanding fiberglass, gelcoat, paint, wood, and metal. Hook-and-loop system holds discs securely for long disc use. Reduces clogging, extends disc life. Accommodates most 5-inch dustless sanders. Available in extra fine, fine, medium and coarse grades.



Part Number	Description	Discs Per Pack	Packs Per Case
<b>Kit</b>			
051144-09173	1 pad, 1 Medium 80 disc	3	8
<b>Discs – No Hole</b>			
051144-09140	Extra Fine – 220 Grit	3	40
051144-09141	Fine – 120 Grit	3	40
051144-09142	Medium – 80 Grit	3	40
051144-09143	Coarse – 40 Grit	3	40
<b>Dust-Free Discs – 8 Hole</b>			
051144-09145	Extra Fine – 220 Grit	3	40
051144-09146	Fine – 120 Grit	3	40
051144-09147	Medium – 80 Grit	3	40
051144-09148	Coarse – 40 Grit	3	40

## 3M™ Dust-Free Hookit™ Discs

Use for sanding fiberglass, gelcoat, paint, wood, and metal. Hook-and-loop system holds discs securely. Special coating reduces clogging, extends disc life. Available in extra fine, fine, medium and coarse grades.



Part Number	Description	Discs Per Pack	Packs Per Case
<b>4" x 8 Hole</b>			
051144-09205	Extra Fine – 220 grit	3	40
051144-09206	Fine – 120 Grit	3	40
051144-09207	Medium – 80 Grit	3	40
051144-09208	Coarse – 40 Grit	3	40
<b>5" x 5 Hole</b>			
051144-09305	Extra Fine – 220 Grit	3	40
051144-09307	Fine – 120 Grit	3	40
051144-09308	Medium – 80 Grit	3	40
051144-09310	Coarse – 40 Grit	3	40
<b>6" x 6 Hole</b>			
051144-09312	Extra Fine – 220 Grit	3	40
051144-09314	Fine – 120 Grit	3	40
051144-09315	Medium – 80 Grit	3	40
051144-09317	Coarse – 40 Grit	3	40

## 3M™ 2" Sanding/Finishing Products

These sanding/finishing products are for use on fiberglass, gelcoat, painted surfaces, wood, metal and plastic. They shape, sand, finish or polish for quick, professional results. Ideal for small or hard-to-reach areas. Conveniently mounts on power drill with holder. The reusable discs switch fast with a quarter-turn. Ideal for polishing/finishing.



Part Number	Description	Quantity Per Case
051144-09100	Kit	6
051144-09101	Disc Holder	12
051144-09102	Discs, Fine Grit	12
051144-09103	Discs, Medium Grit	12
051144-09104	Discs, Coarse Grit	12

# Retail Packaged Abrasive Products

## 3M™ Drill Mounted Grinding/Sanding/Finishing System

The 2" 3M™ Grinding Discs are great for hard-to-reach areas. Quick, interchangeable, reusable attachment system yields professional results. Unique quality tools are compatible with electric and air drills. 3M™ Regalite™ Discs grind through paint, primer, filler and rust. Great for leveling welds. Scotch-Brite™ Discs are outstanding for gasket removing and metal polishing.



Part Number	Description	Quantity Per Pack	Packs Per Case
051131-03050	Finishing Kit Consisting of: 1 Disc Holder, 3 - 2" 3M™ Regalite™ Sanding Discs, 2 - 2" Scotch-Brite™ Discs	1 Kit	6
051131-03051	2" Disc Holder	1 Holder	10
051131-03052	3M™ Regalite™ Sanding Discs Fine 120 Grit	3 Discs	10
051131-03053	3M™ Regalite™ Sanding Discs Medium 80 Grit	3 Discs	10
051131-03054	3M™ Regalite™ Sanding Discs Coarse 40 Grit	3 Discs	10
051131-03055	Scotch-Brite™ Polishing Discs Fine	3 Discs	10
051131-03057	Scotch-Brite™ Stripping Discs Coarse	3 Discs	10

## Scotch-Brite™ Medium Finishing Sander

Mounts directly to power drills by inserting the mandrel into a drill chuck. Use for light sanding of fiberglass, gelcoat, wood, or metal. Drum shape makes it ideal for curves, contours and hard-to-reach areas.



Part Number	Packs Per Case
051144-09415	10

## Scotch-Brite™ Fine Finishing Sander

Mounts directly to power drills by inserting the mandrel into a drill chuck. Use for finish sanding on fiberglass, gelcoat, wood, or metal. Drum shape makes it ideal for curves, contours and hard-to-reach areas.



Part Number	Packs Per Case
051144-09416	10

## 3M™ Scotch-Brite™ 2" Stripping Discs

These stripping discs are for use on fiberglass, gelcoat, painted surfaces, wood, metal and plastic. They shape, sand, finish or polish for quick, professional results. Ideal for small or hard-to-reach areas. Conveniently mounts on power drill with holder. The reusable discs switch fast with a quarter-turn.



Part Number	Description	Case Size	Packs Per Case
051144-09106	Coarse Grit	5.4" x 11.9" x 6.9"	12

## Scotch-Brite™ Flat Surface Paint & Rust Stripper Disc

Attaches to a 3M™ Hook-and-Loop Backup Pad. The disc is for use on flat projects requiring fast removal of surface paint and rust from wood, metal and plastic.



Part Number	Packs Per Case
051144-09410	12

## Scotch-Brite™ Flat Surface Paint & Rust Stripper Kit

3M™ Hook-and-Loop Backup Pad mounts directly to power drill chuck. Hook-and-loop disc mounts to backup pad. Use of flat projects requiring fast removal of surface paint and rust from wood, metal and plastic.



Part Number	Kits Per Case
051111-10954	5

## Scotch-Brite™ Flat Surface Paint & Varnish Remover Kit

3M™ Hook-and-Loop Backup Pad mounts directly to power drill chuck. Hook-and-loop disc mounts to backup pad. Use on flat projects requiring fast removal of surface paint and varnish from wood, metal and plastic.



Part Number	Kits Per Case
051111-10955	5

# Retail Packaged Abrasive Products

## 3M™ Auto-Pak™ Power Rust and Paint Stripper

3M™ Auto-Pak™ Power Rust and Paint Stripper is a one-piece stripper, with a built-in mandrel, that quickly removes rust scale, old paint and grime from metal surfaces. It is made of a synthetic material that molds to any surface and won't rust or splinter like wire brushes.



Part Number	Strippers Per Pack	Packs Per Case
051131-03171	1	24

## Scotch-Brite™ Heavy Duty Rust and Paint Stripper

This double thick Scotch-Brite™ web strips quick, lasts long, and cuts fast. It conforms to surface contours and attaches easily to a standard electric drill.



Part Number	Description	Packs Per Case
051131-03172	4" Diameter	10

## Scotch-Brite™ Flat Surface Paint & Varnish Remover Disc

Attaches to a 3M™ Hook-and-Loop Backup Pad. The disc is for use on flat projects requiring fast removal of surface paint and varnish from wood, metal and plastic.



Part Number	Packs Per Case
051144-09411	12

## Scotch-Brite™ Contour Surface Paint & Varnish Remover

Mounts directly to power drills by inserting the mandrel into a drill chuck. Use for removal of paint and varnish from contoured surfaces on wood, metal and plastic.



Part Number	Packs Per Case
051144-09413	10

## Scotch-Brite™ Large Area Paint & Varnish Remover

Mounts directly to power drills by inserting the mandrel into a drill chuck. Use for removal of paint and varnish from contoured surfaces on wood, metal and plastic. Double-wide for removal of paint and varnish from large areas.



Part Number	Packs Per Case
051144-09414	10

## 3M™ Buffing Pad

Attaches to a 3M™ Hook-and-Loop Backup Pad. When used with the appropriate compound, buffs fine scratches out of gelcoat and marine paints. Ideal for applying cleaners, polishes and waxes.



Part Number	Packs Per Case
051144-09417	10

## 3M™ Polishing Pad

Attaches to a 3M™ Hook-and-Loop Backup Pad. Applies polishes and waxes to gelcoat and marine paints.



Part Number	Packs Per Case
051144-09418	10

## 3M™ Scotch-Brite™ 2" Polishing Discs

These polishing discs are for use on fiberglass, gelcoat, painted surfaces, wood, metal and plastic. They shape, sand, finish or polish for quick, professional results. Ideal for small or hard-to-reach areas. Conveniently mounts on power drill with holder. The reusable discs switch fast with a quarter-turn. Ideal for polishing and finishing.



Part Number	Description	Packs Per Case
051144-09105	Fine Grit	12

# 3M™ Marine Fiberglass Repair Fillers



Type of Repair	= 3M™ Marine High Strength Repair Filler		3M™ Marine Premium Filler	
	ABOVE BELOW THE WATERLINE	ABOVE BELOW THE WATERLINE	ABOVE BELOW THE WATERLINE	ABOVE BELOW THE WATERLINE
<b>Bonding</b>				
• Coring				
• Hardware				
• Structural support				
<b>Filling</b>				
• Blister damage				
• Keel damage				
• Rudder damage				
• Cracks				
• Gouges				
<b>Fairing</b>				
• Hull, deck, parts				

## Fiberglass Repair Fillers

### 3M™ Marine High Strength Repair Filler

3M™ Marine High Strength Repair Filler is a unique vinyl ester formulation designed with short strand fiberglass for semistructural repairs, above and below the waterline. This high performance reinforced filler is designed to repair areas of fiberglass hulls, decks, and other parts.



Part Number	Container Size	Containers Per Case
051131-46012	Pint	6
051131-46013	Quart	6
051131-46014	Gallon	4

### 3M™ Spreaders

Designed for spreading body and fiberglass fillers, finishing putties and resins. These spreaders are flexible, durable and easy to clean. Each has a sharp edge and cured filler pops off easily.



Part Number	Size	Units Per Case
NEW 051131-05842	4"	50
NEW 051131-05843	5"	50
NEW 051131-05844	Assortment 1 each – 4", 5" and 6"	24

### 3M™ Marine Premium Filler

3M™ Marine Premium Filler is a unique easy to sand vinyl ester formulation designed for marine filling and fairing applications above and below the waterline.



Part Number	Container Size	Containers Per Case
051131-46004	Pint	6
051131-46005	Quart	6
051131-46006	Gallon	4

### 3M™ Crème Hardener

A crème hardening agent designed to be used with 3M™ Zebra™ Tack-Free Lightweight Body Filler, 3M™ Lightweight Body Filler, 3M™ Piranha™ Putty, 3M™ Marine High Strength Repair Filler, or 3M™ Marine Premium Filler. Its creamy consistency mixes easily and quickly with any of the above products.

Part Number	Size	Tubes Per Case
NEW 051131-05766	2.75 oz. Tube	12

# Lightweight Fillers and Accessories

## 3M™ Zebra™ Advanced Lightweight Filler

A two-component body filler designed to fill low areas in damaged automotive sheet metal. Sands better than traditional lightweight fillers. Stain-resisting power, adheres to steel, SMC, galvanized steel and aluminum. Vacuum processed for fewer pinholes. Cures tack-free in approximately 20 minutes – reduces sandpaper loading. Advanced formulation.



Part Number	Container Size	Containers Per Case
051131-05868	Gallon	4

## 3M™ Lightweight Body Filler

This vacuum processed lightweight body filler is designed to be used for filling and shaping prototypes and plugs in the OEM Plug/Mold Department. This filler cures tack-free in 15-20 minutes, reducing sandpaper loading. Other important advantages are:

- Creamy texture
- Smooth spreading
- Easy sanding
- Vacuum processed to minimize pinholes



Part Number	Size/Net Weight	Containers Per Case
051131-05801	1 Gallon (7.75 lbs./125 oz.)	4
051131-05802	– No Longer Available –	
051131-05803	– No Longer Available –	

## 3M™ Creme Hardener

A red cream hardening agent designed to be used with 3M™ Lightweight Body Filler. Its creamy consistency mixes easily and quickly.



Part Number	Container Size	Tubes Per Case
051131-05830	2.75 oz. tube	12

## 3M™ Mechanical Dispenser

A rugged, mobile body filler work station for use with 3M™ Lightweight Body Filler (PN05803). Ratchet cranking motion allows for easy dispensing leverage. Piston-driven power provides consistent delivery and complete emptying of pail. Keeps filler free from dust and contaminants. No waste.



Part Number	Dispensers Per Case
051131-05845	1

## 3M™ Crème Hardener

A crème hardening agent designed to be used with 3M™ Zebra™ Tack-Free Lightweight Body Filler, 3M™ Lightweight Body Filler, 3M™ Piranha™ Putty, 3M™ Marine High Strength Repair Filler, or 3M™ Marine Premium Filler. Its creamy consistency mixes easily and quickly with any of the above products.

Part Number	Size	Tubes Per Case
NEW 051131-05766	2.75 oz. Tube	12

# 3M™ Scotchlite™ Glass Bubbles

## 3M™ Scotchlite™ Glass Bubbles

3M™ Scotchlite™ Glass Bubbles are hollow, unicellular, microscopic spheres composed of water, insoluble chemically stable soda-lime borosilicate glass. This filler/resin extender can be used in mixing of marine putties and fairing compounds, as well as in fiberglass reinforced plastic layup. These bubbles offer light-weight, minimal shrinkage and easy sanding. For hand mixing use K1 or K15 series bubbles; for spray applications less than 500 psi use K20 series bubbles; for spray applications less than 750 psi use K25 series bubbles.

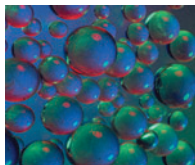

Part Number	Catalog Number	Pounds Per Case
021200- <b>67424</b>	K1	5
021200- <b>67432</b>	K1	40
021200- <b>86416</b>	K15	10
021200- <b>86417</b>	K15	50
021200- <b>86422</b>	K20	10
021200- <b>86423</b>	K20	60
021200- <b>83949</b>	K25	10
021200- <b>83950</b>	K25	80

# Putties

## 3M™ Piranha™ Advanced Finishing Putty

Two component, self-leveling putty designed for use as a "skin" coat over plastic filler to fill pinholes, sand scratches, low areas and other imperfections. Cures tack-free in 30 minutes. Grips tight to galvanized steel, sanded paint, aluminum, steel, SMC and Fiberglass. Extremely easy sanding. Flowable and brushable. Non-staining.



Part Number	Container Size	Tubes Per Case
051131- <b>05821</b>	24 oz. Tube	6

## 3M™ Acryl-Green Spot Putty

3M™ Acryl-Green Spot Putty spreads and sands easily, dries fast, has minimum shrinkage and excellent adhesion. This spot putty is recommended for filling minor imperfections and scratches.



Part Number	Container Size	Tubes Per Case
051144- <b>05960</b>	21 oz. Tube	12

## 3M™ Acryl-Blue Glazing Putty

3M™ Acryl-Blue Glazing Putty spreads and sands easily, dries fast, has minimum shrinkage and excellent adhesion. This glazing putty is recommended for filling minor low areas or deeper sand scratches.



Part Number	Container Size	Tubes Per Case
051144- <b>05964</b>	21 oz. Tube	12

## 3M™ Acryl-Red Putty

3M™ Acryl-Red Putty spreads and sands easily, dries fast, has minimum shrinkage and excellent adhesion. It loads paper less and feathers out to a smooth surface. This putty is recommended for filling pinholes, scratches and grinding imperfections.



Part Number	Container Size	Tubes Per Case
051144- <b>05966</b>	21 oz. Tube	12

## 3M™ Acryl-Marine Putty — White

Designed specifically for the boat repair market, this putty is recommended for filling pinholes, scratches and other surface defects on hulls. Its white color minimizes the possibility of color showing through the final coat as can happen when using colored putties beneath white paint. Other advantages include easy sanding, fast drying, spreads easily, and has low shrinkage.



Part Number	Container Size	Tubes Per Case
051131- <b>05962</b>	21 oz. Tube	12

# 3M Marine Boat Reconditioning and Maintenance Products

## Featuring Unique 3M™ Marine Products and Protective Waxes



### Boat Cleaning

**One  
Step  
Process**

Surface Condition	Reconditioning Purpose	The One Step Solution
<ul style="list-style-type: none"> <li>Clean grime, dirt, etc. from hull, deck and non-skid surfaces</li> </ul>	<ul style="list-style-type: none"> <li>General purpose cleaning</li> </ul>	<ul style="list-style-type: none"> <li>3M™ Marine Multi-Purpose Boat Soap – Light duty Concentration (2 oz. concentrate to 1 gallon water)</li> <li>3M™ Heavy Duty Hull and Deck Cleaner</li> <li>3M™ Non-Skid Cleaner</li> </ul>
<ul style="list-style-type: none"> <li>Clean grime, dirt, etc. from soiled canvas, upholstery, carpet and other marine fabrics</li> </ul>	<ul style="list-style-type: none"> <li>General purpose fabric cleaning</li> </ul>	<ul style="list-style-type: none"> <li>3M™ Marine Multi-Purpose Boat Soap – Medium Concentration (2 oz. concentrate to 1 quart water)</li> <li>3M™ Heavy Duty Hull and Deck Cleaner</li> </ul>
<ul style="list-style-type: none"> <li>Clean grime, dirt and grease</li> </ul>	<ul style="list-style-type: none"> <li>Degrease engines or perform other heavy duty applications</li> </ul>	<ul style="list-style-type: none"> <li>3M™ Marine Multi-Purpose Boat Soap – Heavy Concentration (8 oz. concentrate to 1 quart water)</li> <li>3M™ Heavy Duty Hull and Deck Cleaner</li> <li>3M™ Black Streak Remover</li> </ul>

### Fiberglass Boat Reconditioning (Gelcoat)

**One  
Step  
Process**

Surface Condition	Reconditioning Purpose	The One Step Solution
<ul style="list-style-type: none"> <li>Heavy oxidation, chalking, fading, minor scratches, rust and exhaust stains</li> </ul>	<ul style="list-style-type: none"> <li>Restore, clean, polish and protect surface</li> </ul>	<ul style="list-style-type: none"> <li>3M™ Marine Fiberglass Restorer and Wax</li> </ul>
<ul style="list-style-type: none"> <li>Light to medium oxidation</li> </ul>	<ul style="list-style-type: none"> <li>Clean, Polish and protect surface</li> </ul>	<ul style="list-style-type: none"> <li>3M™ Marine Fiberglass Cleaner and Wax</li> </ul>
<ul style="list-style-type: none"> <li>Clean, non-stained, non-oxidized boats</li> </ul>	<ul style="list-style-type: none"> <li>Protect surface</li> </ul>	<ul style="list-style-type: none"> <li>3M™ Marine Ultra Performance Paste Wax</li> <li>3M™ Marine Protective Liquid Wax</li> </ul>
<ul style="list-style-type: none"> <li>Smudge marks or water spots</li> </ul>	<ul style="list-style-type: none"> <li>In season cleaning and to extend protection</li> </ul>	<ul style="list-style-type: none"> <li>3M™ Marine Clean and Shine Wax Enhancer</li> </ul>

# 3M Marine Boat Reconditioning and Maintenance Products

## Featuring Unique 3M™ Marine Products and Protective Waxes



### Boat Reconditioning and Maintenance

**One  
Step  
Process**

Surface Condition	Reconditioning Purpose	The One Step Solution
<ul style="list-style-type: none"> <li>Dull and dirty vinyl</li> </ul>	<ul style="list-style-type: none"> <li>Rejuvenate and restore luster</li> </ul>	<ul style="list-style-type: none"> <li>3M™ Marine Vinyl Cleaner and Restorer</li> <li>3M™ Marine Outdoor Vinyl Cleaner, Conditioner and Protector</li> </ul>
<ul style="list-style-type: none"> <li>Dull, oxidized or stained aluminum</li> </ul>	<ul style="list-style-type: none"> <li>Removes oxidation, staining or restores luster</li> </ul>	<ul style="list-style-type: none"> <li>3M™ Marine Aluminum Restorer and Polish</li> </ul>
<ul style="list-style-type: none"> <li>Dull, oxidized, stainless steel, brass, bronze and other marine metals</li> </ul>	<ul style="list-style-type: none"> <li>Clean, polish and restore luster</li> </ul>	<ul style="list-style-type: none"> <li>3M™ Marine Metal Restorer and Polish</li> </ul>



# 3M Finishing Systems

Innovative solutions for every finishing application

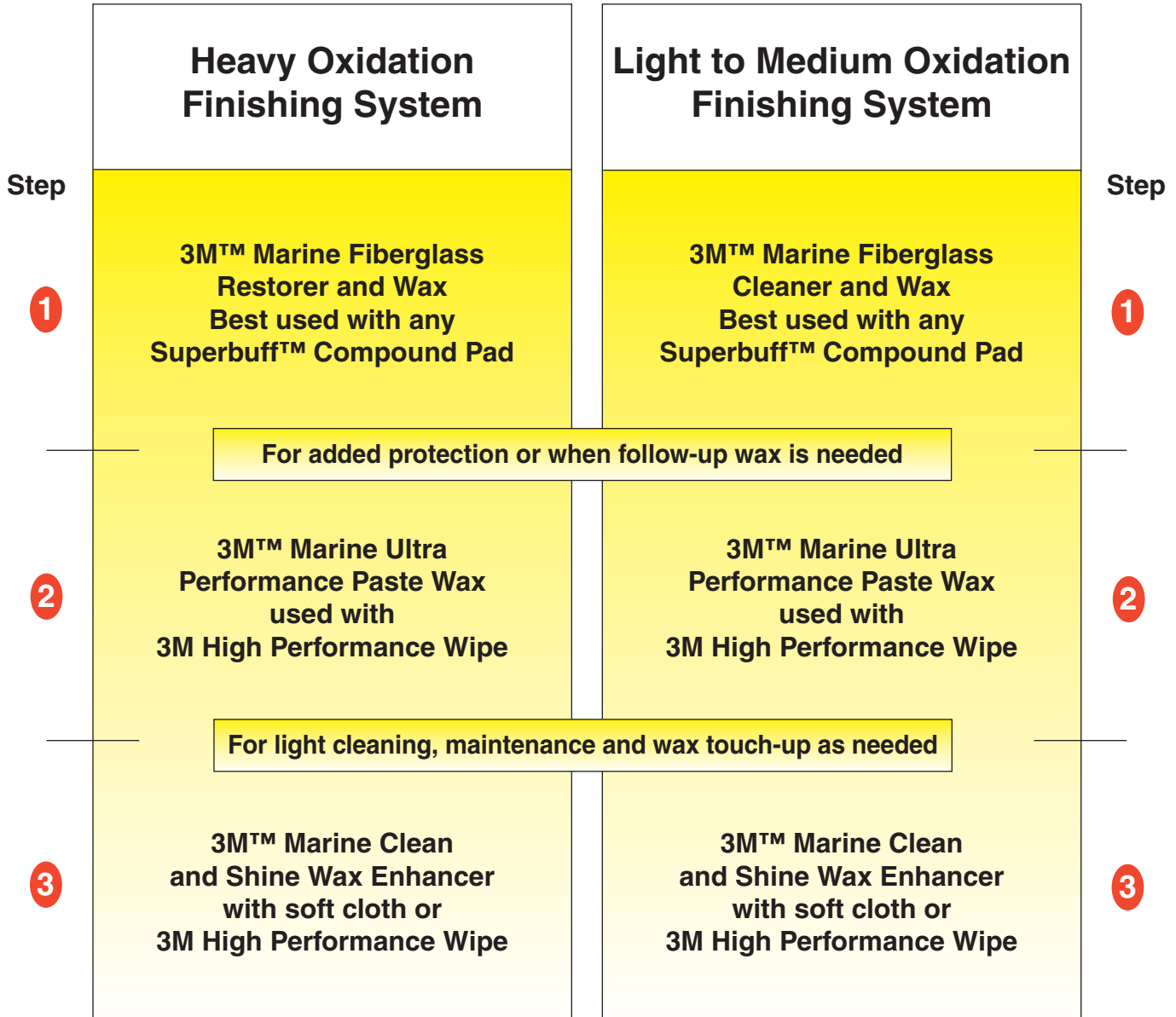

# 3M Finishing Systems

Innovative solutions for every finishing application

Paint Finishing System* Fresh Paint (Air dried 24-48 hours at 70-85°F at 45-65% rh)		Paint Finishing System* Cured Paint (Air dried more than 48 hours at 70-85°F at 45-65% rh)	
Step			Step
1	3M™ 260L Finishing Film P1200 with Low Profile Finishing Disc Pad	3M™ 260L Finishing Film P1200 with Low Profile Finishing Disc Pad	1
2	— OPTIONAL — For Reduced Compounding, use 3M™ Trizact™ Hookit™ II Foam Discs, Grade P3000	— OPTIONAL — For Reduced Compounding, use 3M™ Trizact™ Hookit™ II Foam Discs, Grade P3000	2
3	3M™ Perfect-It™ III Rubbing Compound with any Superbuff™ Compound Pad	3M™ Perfect-It™ III Extra Cut Compound with any Superbuff™ Compound Pad	3
4	3M™ Perfect-It™ III Machine Glaze with Perfect-It™ Foam Polishing Pad	3M™ Perfect-It™ III Machine Glaze with Perfect-It™ Foam Polishing Pad	4
5	3M™ Perfect-It™ III Finishing Glaze with Perfect-It™ III DA Glazing Pad	3M™ Perfect-It™ III Finishing Glaze with Perfect-It™ III DA Glazing Pad	5

\* For acrylated polyester polyurethanes, polyester urethanes, polyurethane enamels and aliphatic polyurethanes.

# 3M Finishing Systems

Innovative solutions for every finishing application

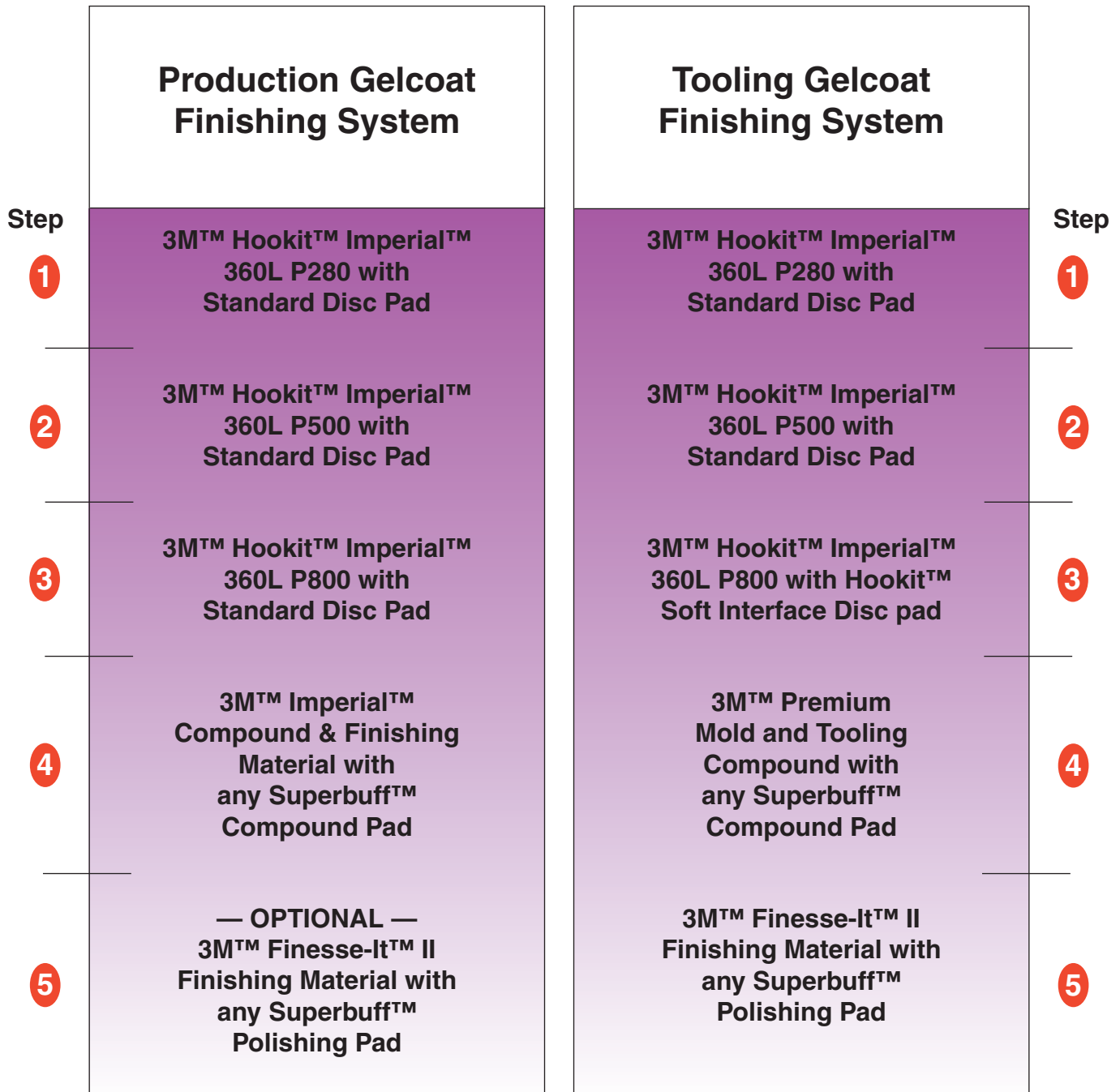

# 3M Finishing Systems

Innovative solutions for every finishing application

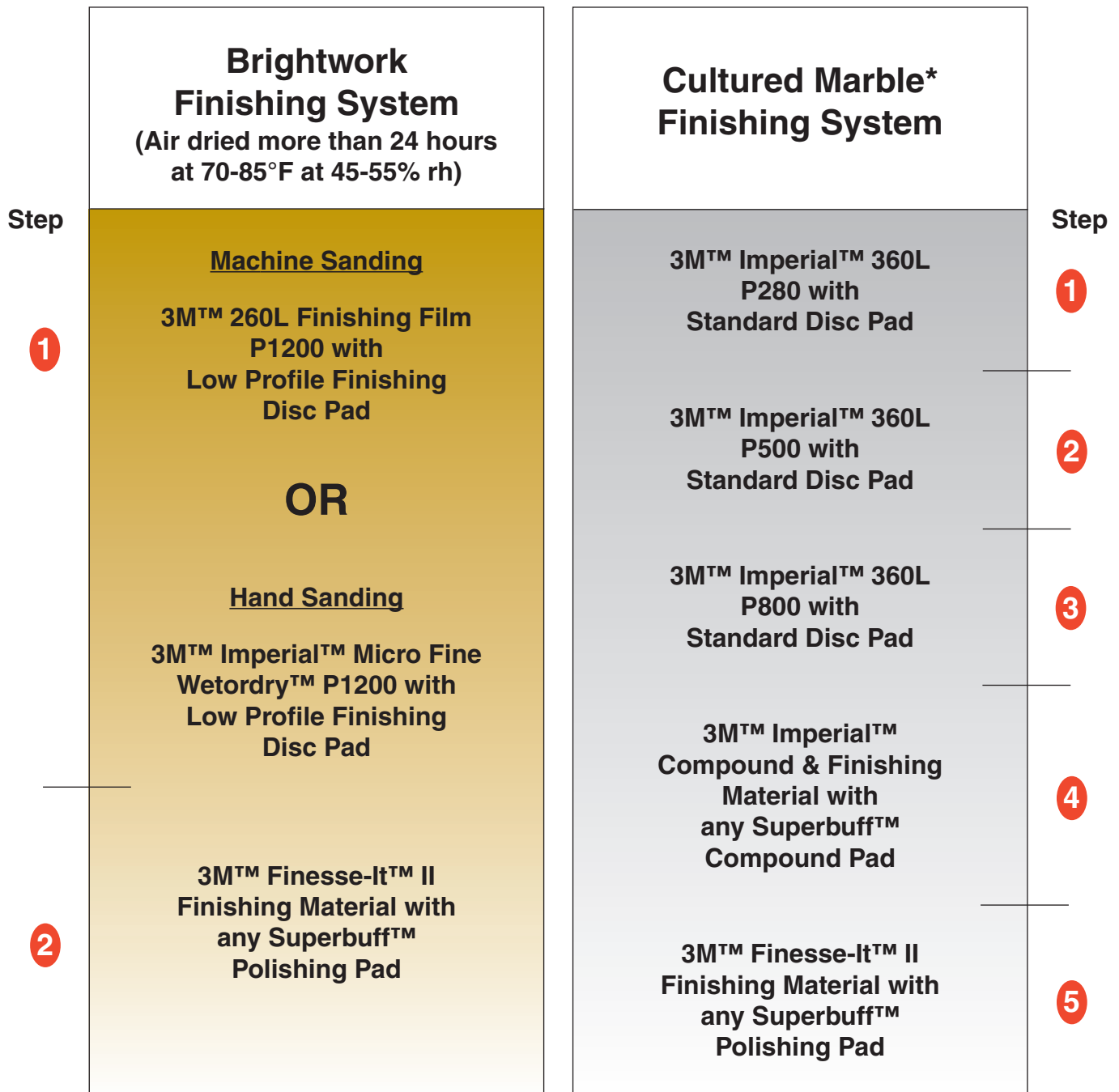

\* Cultured marble is a polyester based synthetic material; it is not stone

# Helpful Hints

(For the 3M™ Marine Plastic Reconditioning Systems)

## 3M™ Marine Plastic Reconditioning Systems

Restore the clarity of acrylic and polycarbonate plastic parts such as boat windshields, portlights and hatch covers with 3M™ Plastic Reconditioning Systems. The 3M™ Plastic Reconditioning System Charts will assist you in determining which procedure and products you need for your plastic reconditioning project. Prior to the start of your plastic reconditioning project, refer to the following helpful hints.



## Plastic Identification of

- **Acrylic Plastic (Plexiglas®, Acrylite®, etc.)\***
- **Polycarbonate Plastic (Lexan®, Tuffak®, etc.)\*\***

Because acrylic plastic has a greater surface hardness than polycarbonate plastic, a simple scratch test can be performed.

1. Find an inconspicuous area of the plastic part, (i.e. corner of a windshield, area underneath a removable trim piece), where a scratch can be put into the plastic without it being noticed.
2. Use a sharp instrument, like the blade of a screwdriver and run the corner of the blade across the plastic.
  - If you hear a scraping sound and/or feel the blade jump across the surface, you are working on acrylic plastic.
  - If no sound is heard while scraping and/or the blade of the screwdriver moves smoothly across the surface, (denting the surface instead of scraping) you are working on polycarbonate plastic.

## Follow These Steps...



**Step 1:** After determining the type of plastic you are working on, begin wet sanding with the recommended abrasive in one direction only. Refer to the chart for abrasive grade.

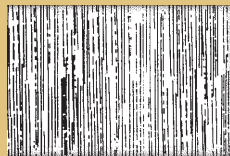

**Step 2:** Wet sand the entire area making sure all the sanding scratches are going in the same direction. The finished area should look similar to this illustration.



**Step 3:** Now using a finer grade abrasive, wet sand in an opposite direction of Step 2 until all the coarser scratches have been eliminated. This is very important for clear results.



**Step 4:** After the sanding steps are complete, the area should look similar to this illustration. Compound and machine glaze using the recommended products in the chart.

\* Plexiglas® is a registered trademark of Rohm and Haas Co.  
Acrylite® is a registered trademark of CYRO Industries.

\*\* Lexan® is a registered trademark of General Electric Co.  
Tuffak® is a registered trademark of Atohaas Americas Inc.

# 3M Finishing Systems

Innovative solutions for every finishing application

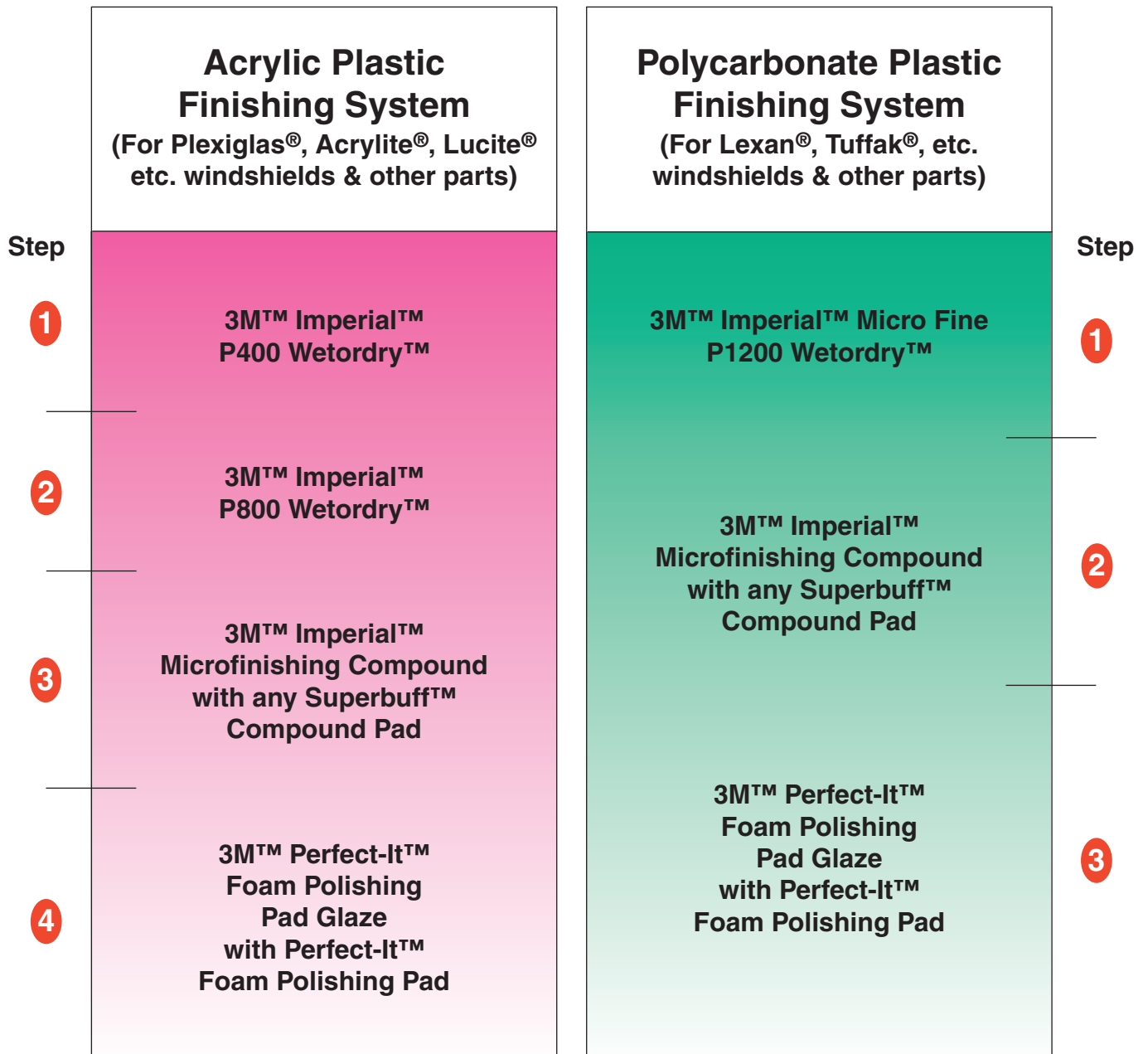

# 3M Marine High-Performance Abrasives

## (Application Chart)

These are general recommendations. When using paints, varnishes, coatings, etc., follow manufacturers' application instructions.

Refinishing Application	Recommended Type and Grade
<b>Varnish</b> <ul style="list-style-type: none"> <li>• Stripping old varnish</li> <li>• Preparation for first coat*</li> <li>• Between coats*</li> <li>• Before final coat*</li> <li>• On final coat**</li> </ul>	<ul style="list-style-type: none"> <li>• Imperial™ P80 Abrasive</li> <li>• Imperial™ P150 Abrasive</li> <li>• Imperial™ P240 Abrasive</li> <li>• Imperial™ P400 Abrasive</li> <li>• 260L Finishing Film P1200</li> </ul>
<b>Bottom Paint</b> <ul style="list-style-type: none"> <li>• Stripping old paint</li> <li>• Preparation for first coat*</li> <li>• Between coats (if needed)*</li> </ul>	<ul style="list-style-type: none"> <li>• Green Corps™ Production™ Fre-Cut™ 24 Abrasive</li> <li>Followed by:</li> <li>• Green Corps™ Production™ Fre-Cut™ 60 Abrasive</li> <li>• Imperial™ P80 Abrasive</li> <li>• Imperial™ P80 Abrasive</li> </ul>
<b>Gelcoat/Fiberglass Repair</b> <ul style="list-style-type: none"> <li>• Stripping old gelcoat</li> <li>• Preparation for fillers</li> <li>• Preparation for spray patch</li> <li>• Sanding after spray patch</li> <li>• Scratch removal</li> <li>• Finish sanding**</li> </ul>	<ul style="list-style-type: none"> <li>• Imperial™ P36 Abrasive</li> <li>• Imperial™ P80 or P40 Abrasive</li> <li>• Imperial™ P180 Abrasive</li> <li>• Imperial™ P280 Abrasive</li> <li>• Imperial™ P500 Abrasive</li> <li>• 360L P800</li> </ul>
<b>Fairing Compound</b> <ul style="list-style-type: none"> <li>• Grinding Imperfections/Fairing Filler</li> <li>• Preparation for fillers</li> <li>• Heavy sanding</li> <li>• Preparation for bottom paint</li> <li>• Preparation for spray patch/primer</li> </ul>	<ul style="list-style-type: none"> <li>• Roloc™</li> <li>• Imperial™ P80 or P40 Abrasive</li> <li>• Imperial™ P36 Abrasive</li> <li>• Imperial™ P80 Abrasive</li> <li>• Imperial™ P180 Abrasive</li> </ul>
<b>Top Side Paint</b> <ul style="list-style-type: none"> <li>• Stripping old paint</li> <li>• Intermediate sanding</li> <li>• Sanding prior to primer</li> <li>• Sanding primer*</li> <li>• Finish Sanding**</li> </ul>	<ul style="list-style-type: none"> <li>• Imperial™ P60 Abrasive</li> <li>• Imperial™ P80 Abrasive</li> <li>• Imperial™ P180 Abrasive</li> <li>• Imperial™ P320 Abrasive</li> <li>• 260L Finishing Film P1200</li> </ul>
<b>Rust Removal on Metal</b> <ul style="list-style-type: none"> <li>• Rust removal</li> </ul>	<ul style="list-style-type: none"> <li>• Imperial™ P80 Abrasive</li> </ul>

\*When using paints, varnishes, coatings, etc. follow manufacturers recommendation

\*\*Before compounding and/or glazing if imperfections require, or brilliant gloss is desired

### Cross-Sanding Definition

Cross-sanding is the technique of ensuring the removal of a coarse scratch by sanding opposite to the coarse scratch with a finer grade abrasive until all the sand scratches are in the same direction as the finer abrasive scratch. Cross-sanding will allow you to see any of the coarser sand scratches you may have missed while sanding with the finer grade abrasive prior to the compounding step.

## Preferred Machine Sanding Techniques



- Do not apply too much pressure while sanding.
- Dual action sander disc pad should be observed spinning during use.
- Lay dual action sander flat; don't ride the edge. Sanding on the edge reduces contact area and increases depth of sand scratch.
- Start with sander flat on the surface. Stop dual action sander with disc off the surface to prevent deep scratches that require additional sanding or buffing.
- Air pressure should be set at tool manufacturer's air pressure recommendation.
- Lower than recommended air pressure may result in deep scratches that require additional sanding or buffing.
- Tips to prevent loading:
  - Clean disc often.
  - Keep tool flat while running.
  - Move tool/DA in consistent pattern and cross-sand.
  - Move tool/DA with consistent pressure.
  - Do not sand in the same spot for too long. This will generate heat.
  - Change disc when dulling/loading begins.



## 3M Preferred Buffing Techniques

- 
- Use buffer that has maximum RPM of 3000
  - Recommended 1500-2500 RPM
  - Buffing out sand scratches coarser than P600 may cause overheating of gelcoat
  - When compounding use a compound pad for cutting
  - Use only clean buff pads
    - A dirty pad can cause scratches
  - Clean pad often while in use
    - Clean with a buffing spur only
  - Buffer should always be stored so that buff pad never touches the floor or workbench
  - Do not allow buffing pads to become contaminated prior to use. Dirty pads can cause swirl marks and scratches
  - Spread compound on 2' X 2' surface before triggering buffer
    - This will eliminate excessive slinging and waste
  - Apply medium pressure when buffing
    - Too much pressure can cause overheating of gelcoat and may result in porosity, comet tails or discoloration
  - Keep compound wet
    - Dry compound can burn gelcoat
  - Keep buff pad flat or at slight angle
    - Do not use on edge as edge of pad can cause burning
  - Always keep compound container covered
    - An open container will become contaminated and can cause unnecessary swirl marks

## Polishing

- Use a polishing pad for glazing and final finish
- When polishing with 3M™ Finesse-It™ II Finishing Material, use new or just washed yellow polishing pad
- Never attempt to polish with used compound pad
  - A used compound pad will create swirl marks

# Buffing and Polishing Pads

## Buffing Pad Characteristics

### Part No.

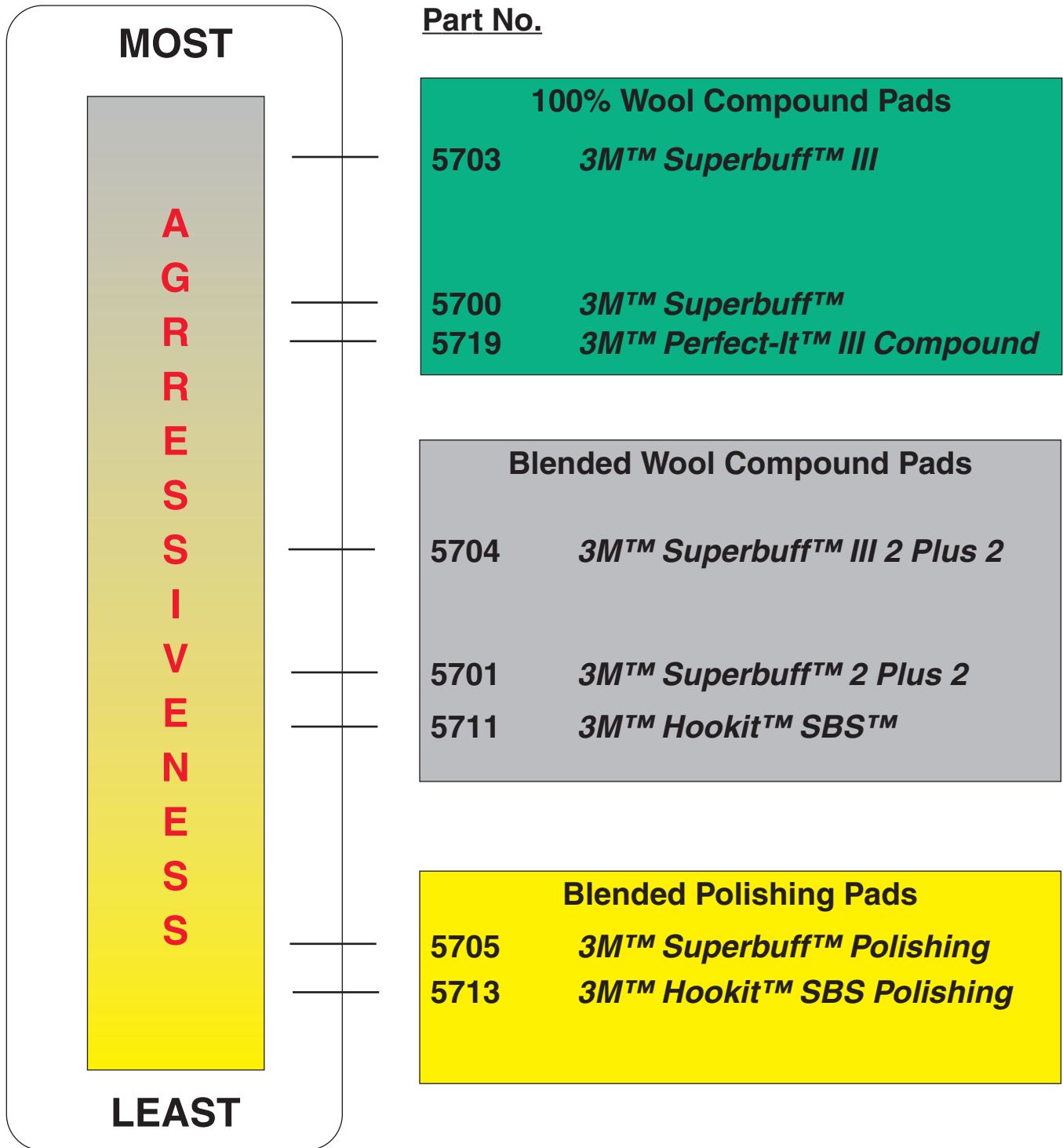

# Boat Reconditioning and Maintenance Products

## 3M™ Marine Fiberglass Restorer and Wax

One Step Process

Designed to remove HEAVY oxidation, chalking, fading, minor scratches, rust and exhaust stains; plus provide protection on fiberglass/gelcoat. Unique formulation combines a rubbing compound with a special blend of waxes which restore shine and protect in one application. Available in liquid and paste versions.



Part Number	Container Size	Containers Per Case
051131-09005	16 fl. oz. (Liquid)	6
051131-09006	32 fl. oz. (Liquid)	6
051131-09007	Gallon (Liquid)	2
051131-09012	Net wt. 18 oz. (Paste)	12

## 3M™ Marine Fiberglass Cleaner and Wax

One Step Process

Designed to remove LIGHT to MEDIUM oxidation, clean, polish and protect fiberglass/gelcoat. Unique liquid formulation combines a compound with a special blend of waxes which restore shine and protect in one application.



Part Number	Container Size	Containers Per Case
051131-09009	16 fl. oz. (Liquid)	6
051131-09010	32 fl. oz. (Liquid)	6
051131-09011	Gallon (Liquid)	2

## 3M™ Marine Super Duty Rubbing Compound

Suggested for heavy, aggressive compounding of oxidized gelcoat and marine paint. Clings to paint and gelcoated surfaces – remains wet on the job with little or no mess. Maintains a high rate of cut with constant pressure. Buffs to high gloss with minimum of swirl marks. Can be used by hand or by machine. Contains no wax or silicone.



Part Number	Container Size	Containers Per Case
051131-09004	16 fl. oz.	6
051131-05954	Quart	12
051144-05955	Gallon	4

## 3M™ Marine Finesse-It™ II Finishing Material

One Step Process

Designed to remove minor scratches and light oxidation while producing a high-gloss “wet look” finish on fiberglass and painted boats. Product contains no wax or silicone. It is also the suggested follow-up step after using 3M™ Marine Super Duty Rubbing Compound (PN09004).



Part Number	Container Size	Containers Per Case
051131-09048	16 fl. oz.	6
051131-05928	Quart	12
051131-05929	Gallon	4

## 3M™ Marine Protective Liquid Wax

Designed to provide high gloss and protect fiberglass/gelcoat, marine topside paints, painted aluminum and marine metal parts. A special formulation which uses reactive chemistry and actually bonds to the boats surface to provide a durable protective surface. Easy on/exceptionally easy off formula which also retards ultraviolet (U.V.) light damage.



	Part Number	Container Size	Containers Per Case
NEW	051131-09026	16 fl. oz. (Liquid)	6
NEW	051131-09027	32 fl. oz. (Liquid)	6

## Wax & Maintenance 6 Pack Rack

Holds six bottles of 3M™ Marine Fiberglass Restorer and Wax (PN09005), or 3M™ Marine Fiberglass Cleaner and Wax (PN09009), or 3M™ Marine Super Duty Rubbing Compound (PN09004) or 3M™ Marine Finesse-It™ II Finishing Material (PN09048). **NOTE: PRODUCTS DO NOT COME WITH THE DISPLAY.**



	Part Number	Description	Racks Per Case
NEW	051131-03004	Rack	6

# Boat Reconditioning and Maintenance Products

## 3M™ Marine Ultra Performance Paste Wax

Contains the unique 3M polymer technology which provides the durability of an acrylic, with the soil release and water beading properties of a fluoropolymer and silicone. This innovative new product will leave a protective high gloss finish on marine fiberglass gelcoat, marine topside paints, painted aluminum and metal parts. The easy-on/easy-off formulation will save time and effort and leave your boat with a long lasting protection that retards ultraviolet (U.V.) light damage.



Part Number	Container Size	Tubs Per Case
051131-09030	9.5 oz. Tub	6

## 3M™ Marine Clean and Shine Enhancer

3M™ Marine Clean and Shine Enhancer is a quick and easy, "spray on/wipe off" product that recaptures that "just waxed" look and feel. Excellent for use on wet or dry surfaces; no water needed! May also be used to enhance the shine of your boats fiberglass gelcoat, marine topside paint, painted aluminum or metal parts. Simply spray on sections that are still wet after washing and rinsing, and revitalize the finish by wiping the surface dry.



Part Number	Container Size	Containers Per Case
051131-09033	15 oz.	6

## 3M™ Marine Metal Restorer and Polish

Designed to restore and polish stainless steel, brass, bronze, copper, chrome, aluminum and other marine metals by removing surface rust, oxidation, corrosion and tarnish. Restores luster.



Part Number	Container Size	Containers Per Case
051131-09018	3 oz. Tube (Paste)	6
051131-09019	Net wt. 18 oz. (Paste)	12

## 3M™ Marine Aluminum Restorer and Polish

Designed to remove oxidation growth and stains and restore a lustrous appearance to bare aluminum. Use sparingly, a little bit goes a long way. Also removes heavy oxidation and restores shine to most painted aluminum surfaces. Great for pontoons and aluminum boats. We recommend testing on small inconspicuous painted areas to determine suitability.



Part Number	Container Size	Containers Per Case
051131-09020	Net wt. 18 oz. (Paste)	6

## 3M™ Marine Vinyl Cleaner and Restorer

Cleans, shines, conditions and protects vinyl, rubber and plastic surfaces. Deep cleans dirt and grime, enhances appearance. Restores natural sheen, protects surfaces. Fresh lemon scent.



Part Number	Container Size	Containers Per Case
051131-09029	15 fl. oz.	6

## 3M™ Marine Outdoor Vinyl Cleaner, Conditioner and Protector

Designed to clean, condition and protect marine vinyl and rubber components. Unique gel formula provides durable protection in exterior, as well as interior applications. Gel formula gives you better application control than liquids. A little bit goes a long way.



Part Number	Container Size	Containers Per Case
051131-09023	8 oz. (Gel)	6

# Boat Reconditioning and Maintenance Products

## 3M™ Marine Multi-Purpose Boat Soap

Concentrated formula designed to clean anything from dirty decks to soiled fabrics to degreasing engines. Mix concentrate with water for desired cleaning strength. Cleans grease, oil, grime, algae, fish, blood, dirt, etc. on hulls, decks, upholstery, canvas, carpet and engines. For example: Mix 2 oz. of 3M™ Marine Multi-Purpose Boat Soap with 1 gallon of water for effective hull and deck cleaning.



Part Number	Container Size	Containers Per Case
051131-09034	16 oz. (Liquid)	6
051131-09035	32 oz. (Liquid)	6

## 3M™ Marine Heavy Duty Hull and Deck Cleaner

The 3M™ Marine Heavy Duty Hull and Deck Cleaner is designed to easily remove algae, grime, oil, fish blood and dirt from fiberglass, metal and painted surfaces. It also removes waterline stains. PN09060 has an easy-to-use spray attachment system.

Part Number	Container Size	Containers Per Case
NEW 051131-09059	500 ml. Spray	6
NEW 051131-09060	32 oz.	6

## 3M™ Marine Black Streak Remover

3M™ Marine Black Streak Remover is designed to remove black streaks. This product is safe for use on fiberglass, metal and painted surfaces.



Part Number	Container Size	Containers Per Case
NEW 051131-09047	500 ml. Spray	6

## 3M™ Marine Non-Skid Deck Cleaner

3M™ Marine Non-Skid Deck Cleaner is designed to clean hard to reach ground-in dirt and stains on non-skid decks. Safe for use on fiberglass, metal and painted surfaces.



Part Number	Container Size	Containers Per Case
NEW 051131-09063	1 Liter	6

## 3M™ Detailing Spray Bottle

A 32-ounce fluorinated bottle. Use with 3M™ Spray Trigger Head (PN37717).



Part Number	Container Size	Containers Per Case
NEW 051131-37716	Spray Bottle	24

## 3M™ Marine Superbuff™ Pad

A 6" diameter buffing pad with a 1" wool pile on both sides of the pad. The 3M™ Marine Superbuff™ Pad allows the do-it-yourselfer to recondition and maintain their boat, using their drill to obtain a high-gloss finish like the professional who uses high-speed tools. The unique double face construction allows both sides of the pad to be used. It has a lightweight support pad built into each pad, thus eliminating the need for heavy rubber backup pads. Designed to fit any standard electric drill with its 1/4" arbor and hex-head nut.



Part Number	Pads Per Case
051131-09038	12

# Compounds

## 3M™ Imperial™ Compound and Finishing Material

3M™ Imperial Compound and Finishing Material has a fast cut and leaves an excellent finish without swirl marks. This liquid compound and finishing material is designed to remove a P600 or P800 dual action sand scratch from gelcoat, with a wool pad. Designed to be used with an air or electric buffer (1500-2500 RPM) equipped with 3M™ Compounding Buff Pads.

Part Number	Container Size	Containers Per Case
051131-06044	32 fl. oz.	12
051131-06045	Gallon	4

## 3M™ Marine High Gloss Gelcoat Compound

This paste compound is designed to quickly remove P600 dual action or 1000 wet sanding scratches from production gelcoat. This compound contains no wax or silicone and leaves a high gloss finish without swirl/wheel marks. It has a unique formulation which reduces slinging while buffing. Best results are obtained when used with a 3M™ Superbuff™ Pad (PN05700) or 3M™ Hookit™ Compounding Pad (PN05711) on a slow-speed polisher (1500-2500 RPM). Follow with 3M™ Marine Finesse-It™ II Finishing Material (PN09048) for a clean and high-gloss finish.



Part Number	Container Size	Containers Per Case
051131-06025	Gallon – 10 lbs.	4
051131-06026	5 Gallon Pail – 50 lbs.	1

## 3M™ Perfect-It™ III Extra Cut Rubbing Compound

The Perfect-It™ III Paint Finishing System is designed for automotive paints (such as acrylated polyester polyurethanes, polyester urethanes, polyurethane enamels and aliphatic polyurethanes). Perfect-It™ III Extra Cut Rubbing Compound has all the features, advantages and benefits of Perfect-It™ III Rubbing Compound with increased aggressiveness to remove 1000-1200 scratches.



Part Number	Container Size	Containers Per Case
051131-05936	Quart	12
NEW 051131-05940	Gallon	4

## 3M™ Perfect-It™ III Rubbing Compound

The Perfect-It™ III Paint Finishing System is designed for automotive paints (such as acrylated polyester polyurethanes, polyester urethanes, polyurethane enamels and aliphatic polyurethanes). 3M™ Perfect-It™ III Rubbing Compound has superior cut combined with a high-gloss ultra-fine finish. It completely removes sand scratches without filling. Easy to detail. Little spatter and sling makes clean up a snap.



Part Number	Container Size	Containers Per Case
051131-05933	Quart	12
NEW 051131-05934	Gallon	4

## 3M™ Marine Premium Mold and Tooling Compound

This premium compound has a unique formulation which aggressively removes sanding scratches in tooling gelcoat (P600 or finer discs with soft interface, 1000 or finer 3M™ Wetordry™ sheets), reducing sanding and compounding time while saving money. It contains no wax or silicone. Follow with 3M™ Marine Finesse-It™ II Finishing Material (PN09048) for a clean and high-gloss finish.



Part Number	Container Size	Containers Per Case
051131-06027	Gallon	4

## 3M™ Super Duty Rubbing Compound

Recommended for heavy aggressive compounding of oxidized gelcoat and marine paint. Clings to paint surface — remains wet on the job with little or no mess. Maintains high rate of cut with constant pressure. Buffs to high gloss with minimum of swirl marks. Can be used by hand or by machine.



Part Number	Container Size	Containers Per Case
051131-09004	Pint	6
051131-05954	Quart	12
051144-05955	Gallon	4

## 3M™ Finesse-It™ Marine Paste Compound — White

3M™ Finesse-It™ Marine Paste compound — White is designed specifically for aggressive compounding of gelcoated fiberglass surfaces. This product is well suited for boat reconditioning of heavily oxidized surfaces/finishes. This product is also well suited for removing P800 sand scratches on production gelcoat and grade 1000 or 1200 sand scratches on tooling gelcoat. White color reduces the potential for staining of light-colored boats. Has long-working time, requiring less compound to be used per application.



Part Number	Container Size	Containers Per Case
051131-06039	Gallon (Paste)	4

## 3M™ Imperial™ Microfinishing Compound

3M™ Imperial™ Microfinishing Compound is specially formulated medium cut compound recommended for removing grade microfine 1200, 1500 and 2000 sand scratches in marine paints.



Part Number	Container Size	Containers Per Case
051131-06011	Quart (Liquid)	12
051131-06021	Gallon (Liquid)	4
051131-06031	Gallon (Paste)	4

# Glazes

## 3M™ Finesse-It™ II Finishing Material

3M™ Finesse-It™ II Finishing Material is designed for use on topside paint systems to remove swirl marks after compounding, while leaving a glazed finish. Also removes light to medium oxidation on gelcoat for boat reconditioning.



Part Number	Container Size	Containers Per Case
051131-09048	Pint	6
051131-05928	Quart	12
051131-05929	Gallon	4

## 3M™ Perfect-It™ III Machine Glaze

The Perfect-It™ III Paint Finishing System is designed for automotive paints (such as acrylated polyester polyurethanes, polyester urethanes, polyurethane enamels and aliphatic polyurethanes). 3M™ Perfect-It™ III Machine Glaze quickly removes compound swirl marks. This glaze produces a high-gloss, swirl-free finish quickly and is easy to clean up. Optimized for those paints listed above.



Part Number	Container Size	Containers Per Case
051135-05937	Quart	12
051135-05938	Gallon	4

## 3M™ Perfect-It™ III Finishing Glaze

The Perfect-It™ III Paint Finishing System is designed for automotive paints (such as acrylated polyester polyurethanes, polyester urethanes, polyurethane enamels and aliphatic polyurethanes). 3M™ Perfect-It™ III Finishing Glaze is hand or DA applied. Apply by DA to save time and effort. This glaze is silicone free and produces a high-gloss, deep-luster durable finish.



Part Number	Container Size	Containers Per Case
051135-05941	Quart	12
051135-05943	Gallon	4

## 3M™ Imperial™ Machine Glaze

3M™ Imperial™ Machine Glaze is a non-silicone, non-wax, machine glaze that possesses excellent scratch removal and filling characteristics and superior depth of shine and luster. Recommended for use by machine to remove and fill swirl marks after compounded acrylic lacquer, it may also be applied to completely cured enamels and urethane paints. 3M™ Imperial™ Machine Glaze is specially formulated to work on all colors.



Part Number	Container Size	Containers Per Case
051131-05991	Quart	12
051131-06001	Gallon	4

## 3M™ Imperial™ Hand Glaze

3M™ Imperial™ Hand Glaze is a non-silicone, non-wax hand glaze, with high filling characteristics, excellent depth of shine and superior luster. Recommended for use by hand to fill swirl marks after compounding acrylic lacquer, it may also be applied to completely cured enamels and urethane paints. 3M™ Imperial™ Hand Glaze is specially formulated to work on all colors, and can be painted over.



Part Number	Container Size	Containers Per Case
051131-05990	Quart	12
051131-06000	Gallon	4

## 3M™ Imperial™ Microfinishing Glaze

Specially designed for finishing fresh 1 to 2 day old enamel and urethane color and clear coat paint systems.



Part Number	Container Size	Containers Per Case
051131-05992	Quart	12

## 3M™ Perfect-It™ Foam Polishing Pad Glaze

3M™ Perfect-It™ Foam Polishing Pad Glazes are uniquely formulated to remove compound swirl marks and leave a wheel-mark-free finish when with the 3M™ Perfect-It™ Foam Polishing Pad (PN05725). Compatible with all types of paint, these glazes contain no wax or silicones. Part No. 05996 provides easy detailing and cleanup on dark colored paints for which it was formulated. 3M™ Perfect-It™ Glazes are also the final step in refinishing acrylic and polycarbonate plastic surfaces.



Part Number	Container Size	Containers Per Case
051131-05995	32 fl. oz. – White	12
051131-05996	32 fl. oz. – Dark	12

## 3M™ Perfect-It™ Wax and Glaze Wipe

This soft non-linting wipe was designed for easy hand application of 3M™ Marine Protective Liquid and Paste Waxes as well as 3M™ “One Step” products. The special non-woven construction will not scratch sensitive marine paint finishes or gelcoat.



Part Number	Wipes Per Box	Boxes Per Case
051131-06009	125	4

# Buffing and Polishing Pads

## 3M™ Superbuff™ III Buffing Pad

3M™ Superbuff™ III Buffing Pad is made of 100% untwisted wool. An aggressive, fast-cutting pad with a stiffer center hub for more cutting power. It is double-sided and excellent for hard paints. Fits all standard (5/8" shaft) slow-speed polishers.



Part Number	Pads Per Case
051131-05703	6

## 3M™ Superbuff™ Buffing Pad

The 3M™ Superbuff™ Buffing Pad has a unique double face construction allowing both sides of the pad to be used plus its own built-in, lightweight support pad eliminates the need for heavy backup pads. The soft usable edge means those hard-to-get-at areas are no longer a problem and edge burn is virtually eliminated. Fits all standard (5/8" shaft) slow-speed polishers.



Part Number	Pads Per Case
051144-05700	24

## 3M™ Superbuff™ III 2 Plus 2 Buffing Pad

3M™ Superbuff™ III 2 Plus 2 Buffing Pad is made of blended untwisted wool with a stiffer center hub for more cutting power. It is double-sided and is less aggressive than 100% wool. Fits all standard (5/8" shaft) slow-speed polishers.



Part Number	Pads Per Case
051131-05704	6

## 3M™ Superbuff™ 2 Plus 2 Pad

This buffing pad is called the "2 Plus 2" because it features 2 sides to buff with plus 2 major advantages.

- More flexible — Gets into tight areas and reverse curves more easily.
- Longer life — Provides greater economics to your buffing operation.



Heavy backup pads are eliminated by the "2 Plus 2" pads' own lightweight support system. Fits all standard (5/8" shaft) slow-speed polishers.

Part Number	Pads Per Case
051144-05701	24

## 3M™ Perfect-It™ III Compound Pad

The 3M™ Perfect-It™ III Compound Pad is a single-sided, 100% wool pad featuring the hook-and-loop attachment system. The 100% wool and untwisted yarn construction offers a fast and more aggressive cut. Economically priced.



Part Number	Pads Per Case
051131-05719	24

## 3M™ Superbuff™ Polishing Pad

The 3M™ Superbuff™ Polishing Pad is a double-sided, soft-edge polishing pad, specially designed for use with a polisher and glaze. Made of extremely fine fibers, the 3M™ Superbuff™ Polishing Pad produces a high gloss on paint and gelcoat surfaces. Other features include: long life, flexibility, lightweight and well balanced. For compounding prior to glazing, one of the other 3M™ Superbuff™ Pads may be used. Fits all standard (5/8" shaft) slow-speed polishers.



Part Number	Pads Per Case
051144-05705	24

## 3M™ Superbuff™ Adaptor

Adaptor for the 3M™ Superbuff™ Pads. For use with 3M™ Superbuff™ Pads, PNs 05700, 05701, 05705, and 05718. Works with 3M™ Perfect-It™ Backup Pad (PN05718).



Part Number	Each Per Case
051144-05710	10

## 3M™ Hookit™ SBS™ System

This uniquely constructed compounding/polishing pad system provides quick change advantages while producing exceptional finishes on gelcoat and paint systems. The 3M™ Hookit™ SBS™ System is designed to provide easy attachment and removal and accurate centering of the 3M™ Hookit™ SBS™ Compounding or Polishing Pad to the 3M™ Hookit™ SBS™ Backup Pad. Fits all standard (5/8" shaft) slow-speed polishers.



Part Number	Description	Pads Per Case
051131-05711	Compounding Pad	24
051131-05713	Polishing Pad	24
051131-05717	Backup Pad	1



# Buffing and Polishing Pads

## 3M™ Perfect-It™ Foam Polishing Pad

3M™ Perfect-It™ Foam Polishing Pad utilizes a 3M patented convoluted foam face to produce a wheel mark free marine topside paint finish or during acrylic and polycarbonate plastic reconditioning, when used in conjunction with 3M™ Perfect-It™ Foam Polishing Pad Glazes. 3M™ Perfect-It™ Foam Polishing Pads attach to either 3M™ Hookit™ Backup Pads (PN05717) or 3M™ Perfect-It™ Backup Pads (PN05718). Fits all standard (5/8" shaft) slow-speed polishers.



Part Number	Pads Per Bag	Bags Per Case
051131-05725	2	12

## 3M™ Perfect-It™ Backup Pad

3M™ Perfect-It™ Backup Pad is a specially designed backup pad for use with the 3M™ Superbuff™ Adaptor (PN05710). This backup pad enables 3M™ Superbuff™ Pad users to use the 3M™ Perfect-It™ Foam Polishing Pad without having to remove the 3M™ Superbuff™ Adaptor from the shaft of the polisher. Fits all standard (5/8" shaft) slow-speed polishers.



Part Number	Pads Per Case
051131-05718	1

## 3M™ Marine Superbuff™ Pad

A 6" diameter buffing pad with a 1" wool pile on both sides of the pad. The 3M™ Marine Superbuff™ Pad allows the do-it-yourselfer to recondition and maintain their boat, using their drill to obtain a high-gloss finish like the professional who uses high-speed tools. It has a lightweight support pad built into each pad, thus eliminating the need for heavy rubber backup pads. Designed to fit any standard electric drill with its 1/4" arbor and hex-head nut.



Part Number	Pads Per Case
051131-09038	12

## 3M™ Finesse-It™ Natural Buffing Pad

These 3" and 5-1/4" buffing pads are designed to get you into tight areas not accessible with a conventional polisher. Pads are hook-and-loop backed. 3" version attaches to the 3" 3M™ Finesse-It™ Roloc™ Finishing Pad (PN14736) which mounts in a 3" 3M™ Roloc™ Disc Pad Assembly (PN05540). 5-1/4" version is used with a dual action sander attached to a 5" 3M™ Hookit™ Backup Pad (PN05775 or 77855).



Part Number	Size	Pads Per Bag	Pads Per Case
051144-81470	3"	10	50
051144-81471	5-1/4"	10	50

## 3M™ Finesse-It™ Roloc™ Finishing Pad

Holds the 3" 3M™ Finesse-It™ Natural Buffing Pad in place. Provides a soft surface for excellent results. Finishing pad mounts in a 3" 3M™ Roloc™ Disc Pad Assembly (PN05540).



Part Number	Size	Pads Per Bag	Pads Per Case
051144-14736	3"	12	12

# Cleaning

## 3M™ Marine Metal Restorer and Polish

One Step Process



Designed to restore and polish stainless steel, brass, bronze, copper, chrome, aluminum and other marine metals by removing surface rust, oxidation, corrosion and tarnish. Restores luster.

Part Number	Container Size	Containers Per Case
051131-09018	3 oz. Tube (Paste)	6
051131-09019	Net wt. 18 oz. (Paste)	12

## 3M™ Marine Aluminum Restorer and Polish

One Step Process



Designed to remove oxidation growth and stains and restore a lustrous appearance to bare aluminum. Use sparingly, a little bit goes a long way. Also removes heavy oxidation and restores shine to most painted aluminum surfaces. Great for pontoons and aluminum boats. We recommend testing on small inconspicuous painted areas to determine suitability.

Part Number	Container Size	Containers Per Case
051131-09020	Net wt. 18 oz. (Paste)	6

## 3M™ Marine Super Duty Rubbing Compound

Suggested for heavy, aggressive compounding of oxidized gelcoat and marine paint. Clings to paint and gelcoated surfaces – remains wet on the job with little or no mess. Maintains a high rate of cut with constant pressure. Buffs to high gloss with minimum of swirl marks. Can be used by hand or by machine. Contains no wax or silicone.



Part Number	Container Size	Containers Per Case
051131-09004	16 fl. oz.	6
051131-05954	Quart	12
051144-05955	Gallon	4

## 3M™ Marine Finesse-It™ II Finishing Material

This polish is designed to remove minor scratches and light oxidation while producing a high-gloss “wet look” finish on fiberglass and painted boats. Product contains no wax or silicone. It is also the suggested follow-up step after using 3M™ Marine Super Duty Rubbing Compound (PN09004).



Part Number	Container Size	Containers Per Case
051131-09048	16 fl. oz.	6
051131-05928	Quart	12
051131-05929	Gallon	4

## 3M™ Marine Protective Liquid Wax

Designed to provide high gloss and protect fiberglass/gelcoat, marine topside paints, painted aluminum and marine metal parts. A special formulation which uses reactive chemistry and actually bonds to the boats surface to provide a durable protective surface. Easy on/exceptionally easy off formula which also retards ultraviolet (U.V.) light damage.



Part Number	Container Size	Containers Per Case
051131-09026	16 fl. oz. (Liquid)	6
051131-09027	32 fl. oz. (Liquid)	6

## 3M™ Marine Ultra Performance Paste Wax

Contains the unique 3M polymer technology which provides the durability of an acrylic, with the soil release and water beading properties of a fluoropolymer and silicone. This innovative new product will leave a protective high gloss finish on marine fiberglass gelcoat, marine topside paints, painted aluminum and metal parts. The easy-on/easy-off formulation will save time and effort and leave your boat with a long lasting protection that retards ultraviolet (U.V.) light damage.



Part Number	Container Size	Tubs Per Case
051131-09030	9.5 oz. Tub	6

# Cleaning

## 3M™ Marine Clean and Shine Enhancer

One Step Process



3M™ Marine Clean and Shine Enhancer is a quick and easy, “spray on/wipe off” product that recaptures that “just waxed” look and feel. Excellent for use on wet or dry surfaces; no water needed! May also be used to enhance the shine of your boats fiberglass gelcoat, marine topside paint, painted aluminum or metal parts. Simply spray on sections that are still wet after washing and rinsing, and revitalize the finish by wiping the surface dry.

Part Number	Container Size	Containers Per Case
051131-09033	15 oz.	6

## 3M™ Marine Outdoor Vinyl Cleaner, Conditioner and Protector

One Step Process



Designed to clean, condition and protect marine vinyl and rubber components. Unique gel formula provides durable protection in exterior, as well as interior applications. Gel formula gives you better application control than liquids. A little bit goes a long way.

Part Number	Container Size	Containers Per Case
051131-09023	8 oz. (Gel)	6

## 3M™ Marine Fiberglass Restorer and Wax

One Step Process



Designed to remove HEAVY oxidation, chalking, fading, minor scratches, rust and exhaust stains; plus provide protection on fiberglass/gelcoat. Unique formulation combines a rubbing compound with a special blend of waxes which restore shine and protect in one application. Available in liquid and paste versions.

Part Number	Container Size	Containers Per Case
051131-09005	16 fl. oz. (Liquid)	6
051131-09006	32 fl. oz. (Liquid)	6
051131-09007	Gallon (Liquid)	2
051131-09012	Net wt. 18 oz. (Paste)	12

## 3M™ Marine Fiberglass Cleaner and Wax

One Step Process



Designed to remove LIGHT to MEDIUM oxidation, clean, polish and protect fiberglass/gelcoat. Unique liquid formulation combines a compound with a special blend of waxes which restore shine and protect in one application.

Part Number	Container Size	Containers Per Case
051131-09009	16 fl. oz. (Liquid)	6
051131-09010	32 fl. oz. (Liquid)	6
051131-09011	Gallon (Liquid)	2

## 3M™ Marine Vinyl Cleaner and Restorer

Cleans, shines, conditions and protects vinyl, rubber and plastic surfaces. Deep cleans dirt and grime, enhances appearance. Restores natural sheen, protects surfaces. Fresh lemon scent.



Part Number	Container Size	Containers Per Case
051131-09029	15 fl. oz.	6

## 3M™ Marine Heavy Duty Hull and Deck Cleaner

The 3M™ Marine Heavy Duty Hull and Deck Cleaner is designed to easily remove algae, grime, oil, fish blood and dirt from fiberglass, metal and painted surfaces. It also removes waterline stains. PN09060 has an easy-to-use spray attachment system.

	Part Number	Container Size	Containers Per Case
NEW	051131-09059	500 ml. Spray	6
NEW	051131-09060	32 oz.	6

# Cleaning

## 3M™ Marine Black Streak Remover

3M™ Marine Black Streak Remover is designed to remove black streaks. This product is safe for use on fiberglass, metal and painted surfaces.



	Part Number	Container Size	Containers Per Case
NEW	051131-09047	500 ml. Spray	6

## 3M™ Marine Non-Skid Deck Cleaner

3M™ Marine Non-Skid Deck Cleaner is designed to clean hard to reach ground-in dirt and stains on non-skid decks. Safe for use on fiberglass, metal and painted surfaces.



	Part Number	Container Size	Containers Per Case
NEW	051131-09063	1 Liter	6

## 3M™ Marine Multi-Purpose Boat Soap

Concentrated formula designed to clean anything from dirty decks to soiled fabrics to degreasing engines. Mix concentrate with water for desired cleaning strength. Cleans grease, oil, grime, algae, fish, blood, dirt, etc. on hulls, decks, upholstery, canvas, carpet and engines. For example: Mix 2 oz. of 3M™ Marine Multi-Purpose Boat Soap with 1 gallon of water for effective hull and deck cleaning.



	Part Number	Container Size	Containers Per Case
	051131-09034	16 oz. (Liquid)	6
	051131-09035	32 oz. (Liquid)	6

## 3M™ Detailing Spray Bottle

A 32-ounce fluorinated bottle. Use with 3M™ Spray Trigger Head (PN37717).



	Part Number	Container Size	Containers Per Case
	051131-37716	Spray Bottle	24

## 3M™ Marine Superbuff™ Pad

A 6" diameter buffing pad with a 1" wool pile on both sides of the pad. The 3M™ Marine Superbuff™ Pad allows the do-it-yourselfer to recondition and maintain their boat, using their drill to obtain a high-gloss finish like the professional who uses high-speed tools. The unique double face construction allows both sides of the pad to be used. It has a lightweight support pad built into each pad, thus eliminating the need for heavy rubber backup pads. Designed to fit any standard electric drill with its 1/4" arbor and hex-head nut.



	Part Number	Pads Per Case
	051131-09038	12

## 3M™ Prep Solvent 70

A water-based solvent used to remove oil, wax, grease and silicone from surfaces prior to coating.



	Part Number	Container Size	Containers Per Case
NEW	051135-08983	Gallon	4

## Scotch-Brite™ High Performance Cloth

The Scotch-Brite™ High Performance Cloth provides ultra cleaning power because of its knitted, interwoven design of water- and oil-absorbing microfibers that lift and trap liquids, grease, dust and dirt particles. Surfaces are left cleaner than with conventional wipes. When used dry or damp, it's excellent for the removal of grease and silicone from injection molded parts, solvents, dust residue, abrasive residue, splatter from welding, compounds, polish residues, waxes and fingerprints.



	Part Number	Color	Size	Cloths Per Pack	Packs Per Case
	<b>Retail Package</b>				
	051131-67408	Blue	32cm x 36cm	1	12

# Cleaning

## 3M™ Carpet Spot Remover and Upholstery Cleaner

A 19 oz. aerosol can designed to clean carpets and upholstery. Releases both oil and water-based soils from carpet and upholstery. Aerosol foam is sprayed directly on spot with minimum of over spray. Requires no rinsing. Wipe or blot area with a clean absorbent cloth.



Part Number	Container Size	Cans Per Case
048011- <b>14003</b>	19 oz. Aerosol	12

## 3M™ Tarnishield™ Silver Cleaner

Cleans tarnish away quickly, easily, safely. Polishes as it cleans. Restores natural luster.



Part Number	Container Size	Containers Per Case
021200- <b>76546</b>	10 oz.	6

## 3M™ Tarnishield™ Copper and Brass Cleaner

Protects as it polishes. Patented ingredient creates an invisible shield that locks tarnish out. Contains no harsh abrasives.



Part Number	Container Size	Containers Per Case
021200- <b>76547</b>	10 oz.	6

## Scotchgard™ Fabric Protector

An effective, safe, easy do-it-yourself-at-home method of treating fabrics. Offers convenient and lasting protection against soil, stains and rain.



Part Number	Container Size	Cans Per Case
021200- <b>00213</b>	14 oz. Aerosol	12

## Scotchgard™ Water Repellent for Outdoor Fabrics

Scotchgard™ Water Repellent for Outdoor Fabrics is for heavy-duty repellency. Scotchgard™ Water Repellent for Outdoor Fabrics extra-strength formula gives added protection against rain, salt water, dirt and oily spills. Consumers have indicated a need for heavy-duty water and stain protection for their high-quality outdoor fabrics. Scotchgard™ Water Repellent for Outdoor Fabrics causes no change in look, feel or breathability of fabrics. Great for canvas and outdoor apparel.



Part Number	Container Size	Cans Per Case
021200- <b>59129</b>	14 oz. Aerosol	6

## 3M™ Glass Cleaner

3M™ Glass Cleaner is an easy to use, quick acting, non-streaking aerosol glass cleaner. Excellent for cleaning glass; this product is also effective for use on plastic, chrome or metal.



Part Number	Container Size	Cans Per Case
051135- <b>08888</b>	20 oz. Aerosol	12

## Scotchgard™ Cleaner for Rugs and Carpet

A unique carpet cleaner with patented Scotchgard™ protector ingredient so carpets stay cleaner longer. Aerosol will clean 9' x 12' area.



Part Number	Container Size	Cans Per Case
021200- <b>76418</b>	18.5 oz. Aerosol	6

## Scotchgard™ Upholstery Cleaner and Protector

Designed to clean and protect so spills blot up easily.



Part Number	Container Size	Cans Per Case
021200- <b>01748</b>	14 oz. Aerosol	6

## 3M™ General Purpose Adhesive Cleaner

A specially blended solvent that provides easy cleanup of most types of adhesives, and quickly removes waxes, greases, oil and tars. When properly used, it will not harm thoroughly dried paint, vinyl or fabrics.



Part Number	Container Size	Containers Per Case
051135- <b>08984*</b>	Quart Can	6
051135- <b>08986*</b>	5 Gallon Pail	1
051135- <b>08987</b>	20 oz. Aerosol Can	12

\* This product cannot be purchased for use in Southern California per the California South Coast Air Quality District Rule 1171.

# Cleaning

## 3M™ Citrus Base Industrial Cleaner

3M™ Citrus Base Industrial Cleaner is an aerosol, all-natural cleaner which will dissolve and flush away dirt, grease, tar, most non-curing type adhesive films, and similar substances. It is a citrus oil based cleaner that emulsifies when flushed with water. It contains no petroleum distillates. It can be used to clean and degrease metal parts, motors, tools, concrete, or any dirty or greasy surfaces. Contains no methylene chloride, 1,1,1-trichloroethane or chlorofluorocarbons.



	Part Number	Container Size	Cans Per Case
	021200- <b>76394</b>	24 oz.	12
NEW	021200- <b>49179</b>	6 fl. oz.	6

## 3M™ Stainless Steel Cleaner and Polish

This easy-to-apply cleaner and polish is ideally suited for stainless steel, chrome, laminated plastics and aluminum surfaces. With a high-gloss formula, it wipes clean with no streaks or build-up, resists fingerprints and masks surface blemishes. Pleasant lime fragrance. Contains no petroleum distillates.



	Part Number	Container Size	Containers Per Case
NEW	048011- <b>14002</b>	21.5 oz.	12
	048011- <b>19927</b>	Quart	6

## 3M™ Liquid Stainless Steel Cleaner

This easy to apply cleaner is ideally suited for stainless steel, chrome, laminated plastics and aluminum surfaces. With a high-gloss formula, it wipes clean with no streaks or build-up, resists fingerprints and masks surface blemishes. Pleasant lime fragrance. Contains no petroleum distillates.

	Part Number	Container Size	Containers Per Case
NEW	048011- <b>19927</b>	Quart	6

## 3M™ Doodlebug™ Cleaning System

You have your choice of three holders and the industry-leading Scotch-Brite™ Pads. Use for cleaning and scrubbing decks, non-skid areas and hulls.

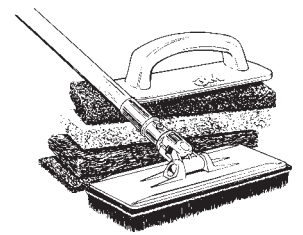

## 3M™ Insta-Lok™ Doodlebug™ Pad Holder Kit

This holder has a swivel head and is most commonly used with a 1-1/8" by 5 ft wooden broom handle, which is not part of the package. Each kit includes one 3M™ Doodlebug™ White Cleaning Pad (PN8440) and one 3M™ Doodlebug™ Brown Scrub 'N Strip Pad (PN8541).



Part Number	Kits Per Case
<b>6472</b>	4

## 3M™ Insta-Lok™ Doodlebug™ Pad Holder Kit

This holder is gripped directly by hand. Each kit includes one 3M™ Doodlebug™ White Cleaning Pad (PN8440) and one 3M™ Doodlebug™ Brown Scrub 'N Strip Pad (PN8541).



Part Number	Kits Per Case
<b>6473</b>	4

## 3M™ Doodlebug™ White Cleansing Pad

Designed for delicate surfaces and light cleaning jobs. Great for windows, ceramic tile, etc.



Part Number	Size	Pads Per Box	Boxes Per Case
<b>8440</b>	4-1/2" x 10"	5	4

## 3M™ Doodlebug™ Blue Cleaning Pad

Designed for medium duty cleaning jobs.

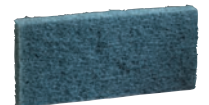

Part Number	Size	Pads Per Box	Boxes Per Case
<b>8242</b>	4-1/2" x 10"	5	4

# Cleaning

## 3M™ Doodlebug™ Brown Scrub 'N Strip Pad

A heavy duty pad designed for tough cleaning and stripping jobs.



Part Number	Size	Pads Per Box	Boxes Per Case
8541	4-1/2" x 10"	5	4

## 3M™ Doodlebug™ High Productivity Stripping Pad — No. 8550

This pad is now the most aggressive pad in the 3M™ Doodlebug™ pad line. It is designed for heavy duty maintenance and stripping applications. This pad must be attached to PN8440 3M™ Doodlebug™ White Cleansing Pad. The 3M™ Doodlebug™ White Cleansing Pad will then attach to any of the 3M™ Doodlebug™ Holders (No. 250, 6472, and 6473).



Part Number	Size	Pads Per Box	Boxes Per Case
8550	4-5/8" x 10"	10	4

## 3M™ Doodlebug™ General Purpose Brush — No. 4020

This brush features non-abrasive, polypropylene bristles which will not scratch fiberglass surfaces and resists common boat cleaning and detergent solutions. This brush works well for cleaning fiberglass boat decks, non-skid deck areas and boat bottoms. It attaches securely to all 3M™ Doodlebug™ Holders.



Part Number	Size	Brushes Per Case
048011-14020	3-3/4" x 9-1/4"	8

## 3M™ Refresh™ Multi-Purpose Glass Cleaning Wipe

3M™ Refresh™ Glass Cleaning Wipe, convenient and easy to use, removes hazy film and cleans plastic, chrome and metal. It features a non-streaking formula that is safe for painted surfaces and tinted windows.



	Part Number	Description	Each Per Case
NEW	03587	24 ea.	24
NEW	03587CS	Clip Strip – 2 strips of 12 ea.	24

## 3M™ Scotch-Brite® Lens Cleaning Cloth

Ribbon-shaped fibers lift dirt and grease instead of rolling over it. Dirt and particles are trapped within knitted tufts of the fibers. Rows and rows of tufts and valleys trap large and small particles.



	Part Number	UPC Number	Description	Each Per Case
NEW	9021	051111-11169	Lens Cloth with Countertop Merchandiser	20
NEW	9021CS	051111-11239	Clip Strip	2 Clips of 6

## O-Cel-O™ Stay Fresh Home, Car and Boat Sponge

O-Cel-O™ Home, Car and Boat Sponge is an excellent choice for big cleaning jobs on your boat. Excellent boat bailer.



Part Number	UPC Number	Size	Sponges Per Case
7220T	053200-07220	9" x 4-1/2" x 1-3/4"	12

## 3M™ C-31 Large Commercial Sponge

3M™ C-31 Large Commercial Sponge is an excellent quality sponge for multiple boat cleanup duties.



Part Number	UPC Number	Size	Sponges Per Case
7449T	053200-07449	6" x 4-1/4" x 1-5/8"	24

## 3M™ C-41 Extra Large Commercial Sponge

3M™ C-41 Extra Large Commercial Sponge is an excellent quality, highly absorbent sponge for multiple boat cleanup duties.



Part Number	UPC Number	Size	Sponges Per Case
7456T	053200-07456	7-1/2" x 4-3/8" x 2-1/16"	24

## Scotch-Brite™ High Performance Cloth

The Scotch-Brite™ High Performance Cloth provides ultra cleaning power because of its knitted, interwoven design of water- and oil-absorbing microfibers that lift and trap liquids, grease, dust and dirt particles. Surfaces are left cleaner than with conventional wipes. When used dry or damp, it's excellent for the removal of grease and silicone from injection molded parts, solvents, dust residue, abrasive residue, splatter from welding, compounds, polish residues, waxes and fingerprints.



Retail Package

Part Number	Color	Size	Cloths Per Case
048011-23589	Blue	32cm x 36cm	50
048011-23649	White	32cm x 36cm	50
048011-23650	Green	32cm x 36cm	50
048011-23651	Yellow	32cm x 36cm	50
048011-23652	Red	32cm x 36cm	50
048011-25899	Gray	32cm x 36cm	25

Part Number	Color	Size	Cloths Per Pack	Packs Per Case
048011-25972	Blue	32cm x 36cm	3	10
048011-25942	Blue	32cm x 36cm	5	10
048011-25963	Red	32cm x 36cm	5	10
<b>Retail Package</b>				
051131-67408	Blue	32cm x 36cm	1	12

# Cleaning

## Scotch-Brite™ Scrubs

Three grades of Scotch-Brite™ material permanently bonded to a handle to provide ease and quickness for a variety of cleaning tasks.



Part Number	Product Type	Each Per Pack	Each Per Case
021200-01008	Grill-Black (7721)	4	12
021200-01009	Floor-Blue (7722)	4	12
021200-01010	Bath-White (7723)	4	12

## Scotch-Brite™ Tub & Sink Scrub Sponge — No. 445

Durable nonwoven nylon laminated to a pure cellulose sponge.



Part Number	Sponges Per Case
021200-00002	12

## 3M™ Sharpshooter Extra Strength No Rinse Cleaner

This special cleaner is designed to remove such tough stains as grease, lipstick, crayon, black heel marks and smoke film from most washable hard surfaces. Use on walls, floors, partitions, vinyl, chrome, grout, stainless steel, Formica, fiberglass, ceramic or porcelain.



Part Number	Container Size	Containers Per Case
048011-13702	5 Gal. Container	10
048011-16861	Quart with 2 Nozzles	12
048011-19344	Quart with 12 Nozzles	12
048011-17933	2 oz. Bottle	48
048011-19349	55 Gal. Container	1

## 3M™ Head Bowl Scrubber

This 3M™ Scrubber features a tough, long-lasting pad with no bristles to flatten out. The 3M™ Head Bowl Scrubber has a strong, durable handle for reaching hard-to-get-at areas.



Part Number	Each Per Case
021200-01082	12

## 3M™ Synthetic Steel Wool Pads

3M™ Synthetic Steel Wool Pads are a combination of synthetic fibers and abrasive particles that work like steel wool. Yet these durable pads are easier on hands, resist clogging, and can be rinsed and reused. 3M™ Synthetic Steel Wool Pads won't rust, splinter or shred. They outlast steel wool. 3M™ Synthetic Steel Wool Pads are compatible with both solvent-based and water-based stains and finishes.



Part Number	Grade	Pads Per Pack	Packs Per Case
051111-10115	#3 Coarse	6	18
051111-10116	#2 Medium	6	18
051111-10118	'0' Fine	6	18
051111-10120	'000' Extra Fine	6	18

## 3M™ General Purpose Adhesive Cleaner

A specially blended solvent that provides easy cleanup of most types of adhesives, and quickly removes waxes, greases, oil and tars. When properly used, it will not harm thoroughly dried paint, vinyl or fabrics.



Part Number	Container Size	Containers Per Case
051135-08984*	Quart Can	6
051135-08986*	5 Gallon Pail	1
051135-08987	20 oz. Aerosol Can	12

\* This product cannot be purchased for use in Southern California per the California South Coast Air Quality District Rule 1171.



# Cleaning

## 3M™ Body Shop Clean-Up™ Products\*

The 3M™ Body Shop Clean-Up™ Products are an abbreviated version of the larger 3M™ Detailing System. Besides the product offering, the main difference in the two lines is that the 3M™ Body Shop Clean-Up™ Products contain no silicone, so they are far more appropriate for areas where paint is being applied. Also, the 3M™ Body Shop Clean-Up™ Products are available for general distribution, whereas the 3M™ Detailing System is not. Both lines include state-of-the-art products designed to achieve the ultimate in superior detailing system performance. The products incorporate safety and technological advancements for superior results. The 3M™ Body Shop Clean-Up™ Products include a limited line of exterior and interior cleaners and dressings, as well as an easy dispensing system. Key benefits to using the system include customer satisfaction, performance, value and safety.

\*THESE PRODUCTS HAVE NOT BEEN TESTED ON MARINE-SPECIFIC SUBSTRATES OR IN MARINE-SPECIFIC APPLICATIONS. THEREFORE, THE PRODUCTS SHOULD BE TESTED BY ANY MARINE CUSTOMER FOR SUITABILITY. THEY ARE FINE TO RECOMMEND FOR AUTOMOTIVE PAINT APPLICATIONS (SUCH AS RV).

## 3M™ Tire Dressing (Concentrate)

Conditions rubber and vinyl surfaces. Contains no silicone and is paint shop safe.



	Part Number	Container Size	Containers Per Case
NEW	051131- <b>38327</b>	1 Gallon	4
NEW	051131- <b>38328</b>	5 Gallon	1

## 3M™ All Purpose Cleaner and Degreaser (Concentrate)

Cleaner/degreaser concentrate for exterior and interior cleaning. Use for vinyl, cloth or carpet cleaning. Paint shop safe, contains no silicone. Dilution – 1 part product to 15 parts water for degreasing, door jambs and pre-spotting carpets. Dilution – 1 part product to 30 parts water for general purpose interior cleaning.



	Part Number	Container Size	Containers Per Case
NEW	051131- <b>38350</b>	1 Gallon	4
NEW	051131- <b>38351</b>	5 Gallon	1

## 3M™ Heavy Duty Wheel Cleaner (Concentrate)

Does not contain Hydrofluoric or other strong acids. Paint shop safe, contains no silicone. Removes brake dust from wheels and rims. Use with 3M™ All Purpose Cleaner and Degreaser for removal of dirt, grease and oil from wheels and rims. Effective for removing water spots from exterior painted vehicle surfaces. Not recommended for use on non-coated wheels, engines or glass. Dilution – 1 part product to 2 parts water.



	Part Number	Container Size	Containers Per Case
NEW	051131- <b>38374</b>	1 Gallon	4
NEW	051131- <b>38375</b>	5 Gallon	1

## 3M™ Car Wash Soap (Concentrate)

Safely removes dirt and grime without removing wax protection. Lubricant for 3M™ Perfect-It™ III Cleaner Clay. Paint shop safe, contains no silicone and is phosphate-free. Excellent for wet sanding lubricant. Dilution – 1 part product to 100 parts water.



	Part Number	Container Size	Containers Per Case
NEW	051131- <b>38377</b>	1 Gallon	4
NEW	051131- <b>38378</b>	5 Gallon	1

## 3M™ Glass Cleaner (Concentrate)

This non-streaking formula is ammonia-free. Paint shop safe, contains no silicone. Dilution – 1 part product to 8 parts water.



	Part Number	Container Size	Containers Per Case
NEW	051131- <b>38399</b>	1 Gallon	4
NEW	051131- <b>38300</b>	5 Gallon	1

## 3M™ Detailing Spray Bottle

A 32-ounce fluorinated bottle. Use with 3M™ Spray Trigger Head (PN37717).



	Part Number	Container Size	Containers Per Case
NEW	051131- <b>37716</b>	Spray Bottle	24

# Cleaning

## 3M™ Detailing General Purpose Spray Trigger Nozzle Head

This long-lasting, adjustable sprayer is red and white in color. The sprayer is for use with water-based 3M™ Detailing Products. For solvent-based 3M products, use 3M™ Solvent Spray Trigger Nozzle Head (PN37718).



	Part Number	Description	Each Per Case
NEW	051131- <b>37717</b>	Spray Head	24

## 3M™ Detailing Product — Diluter

Automatically mixes to proper dilution ratios. Cost-effective and controls mixing. Preset for five 3M™ Detailing Products. 3M™ All Purpose Cleaner and Degreaser at 1 to 15 and 1 to 30, 3M™ Glass Cleaner, 3M™ Heavy Duty Wheel Cleaner and 3M™ Car Wash Soap.



	Part Number	Description	Each Per Case
NEW	051131- <b>37711</b>	Diluter	1

## 3M™ Perfect-It™ III Cleaner Clay

Safely removes overspray and paint contaminants. Use with water-based lubricants. Effective on paint, glass and chrome.



	Part Number	Containers Per Case
NEW	051131- <b>38070</b>	6

## 3M™ All Purpose Cleaner and Degreaser

Cleaner/degreaser for exterior and interior cleaning. Removes dirt, grease and oil from engines, door jambs, rocker panels and tires. Removes insect residue from vehicle bumpers, grills, hoods, etc. Apply over 3M™ Heavy Duty Wheel Cleaner on wheels and rims. Use for pre-spotting interior stains. Dilution – 1 part product to 15 parts water: cleans dirt, stains and soils from carpet and fabric, cleans heavily soiled leather upholstery; 1 part product to 30 parts water: cleans interior vinyls and plastics, cleans lightly soiled leather upholstery.



	Part Number	Container Size	Containers Per Case
NEW	051131- <b>38050</b>	1 Gallon	4
NEW	051131- <b>38051</b>	5 Gallon Pail	1
NEW	051131- <b>38052</b>	55 Gallon Drum	1

## 3M™ Engine & Vehicle Degreaser

Safely removes dirt, grease and oil from engines, door jambs, rocker panels and tires. Apply over 3M™ Heavy Duty Wheel Cleaner on wheels and rims. Dilution – 1 part product to 3 parts water.



	Part Number	Container Size	Containers Per Case
NEW	051131- <b>38071</b>	1 Gallon	4
NEW	051131- <b>38072</b>	5 Gallon Pail	1
NEW	051131- <b>38073</b>	55 Gallon Drum	1

## 3M™ Heavy Duty Wheel Cleaner

Does not contain hydrofluoric or other strong acids. Removes brake dust from wheels and rims. Use with 3M™ All Purpose Cleaner and Degreaser or 3M™ Engine & Vehicle Degreaser for removal of dirt, grease and oil from wheels and rims. Effective for removing water spots from exterior painted vehicle surfaces. Not recommended for use on non-coated wheels, engines or glass. Dilution – 1 part product to 2 parts water.



	Part Number	Container Size	Containers Per Case
NEW	051131- <b>38074</b>	1 Gallon	4
NEW	051131- <b>38075</b>	5 Gallon Pail	1
NEW	051131- <b>38076</b>	55 Gallon Drum	1

## 3M™ Car Wash Soap

Safely removes dirt and grime without removing wax protection. Lubricant for 3M™ Perfect-It™ III Cleaner Clay. 3M™ Car Wash Soap is phosphate-free. Dilution – 1 part product to 100 parts water.



	Part Number	Container Size	Containers Per Case
NEW	051131- <b>38077</b>	1 Gallon	4
NEW	051131- <b>38078</b>	5 Gallon Pail	1
NEW	051131- <b>38079</b>	55 Gallon Drum	1

# Cleaning

## 3M™ Adhesive & Tar Remover

This specially blended solvent quickly removes road tar and adhesive residue. 3M™ Adhesive & Tar Remover will not harm most thoroughly cured automotive paints, vinyls or plastics when properly used.



Part Number	Container Size	Containers Per Case
NEW 051131-38080	1 Gallon	4
NEW 051131-38081	5 Gallon Pail	1
NEW 051131-38082	55 Gallon Drum	1

## 3M™ Engine Dressing

3M™ Engine Dressing uniformly coats and shines engine hoses, plastics and moldings. Does not harm vehicle rubber parts. Dilution – 1 part product to 1 part water.



Part Number	Container Size	Containers Per Case
NEW 051131-38124	1 Gallon	4
NEW 051131-38125	5 Gallon Pail	1
NEW 051131-38126	55 Gallon Drum	1

## 3M™ Transit Coating Remover

3M™ Transit Coating Remover is a blend of petroleum solvents and surfactants. Loosens and helps remove the protective transit coating from vehicle surfaces. Use with 3M™ All Purpose Cleaner and Degreaser or 3M™ Engine & Vehicle Degreaser on engine compartments.



Part Number	Container Size	Containers Per Case
NEW 051131-38134	1 Gallon	4
NEW 051131-38135	5 Gallon Pail	1
NEW 051131-38136	55 Gallon Drum	1

## 3M™ Extraction Cleaner

3M™ Extraction Cleaner cleans carpet and upholstery. Specifically designed for use in extraction equipment. Recommend pre-spotting stains with 3M™ All Purpose Cleaner and Degreaser or 3M™ Multi-Purpose Cleaner. Dilution – 1 part product to 250 parts water.



Part Number	Container Size	Containers Per Case
NEW 051131-38095	1 Gallon	4
NEW 051131-38096	5 Gallon Pail	1

## 3M™ Autobody Solvent

3M™ Autobody Solvent is a special blend of petroleum solvents and surfactants. Removes road tar and adhesive residue. Will not harm most thoroughly cured automotive paints, vinyls or plastics when properly used.



Part Number	Container Size	Containers Per Case
NEW 051131-38137	1 Gallon	4
NEW 051131-38138	5 Gallon Pail	1
NEW 051131-38139	55 Gallon Drum	1

## 3M™ Glass Cleaner

3M™ Glass Cleaner is an ammonia-free, non-streaking formula. Dilution – 1 part product to 8 parts water.



Part Number	Container Size	Containers Per Case
NEW 051131-38099	1 Gallon	4
NEW 051131-38100	5 Gallon Pail	1
NEW 051131-38101	55 Gallon Drum	1

## 3M™ Tire Dressing

3M™ Tire Dressing gives a deep black, lustrous appearance to vehicle tires and vehicle door and trunk moldings. Also effective on exterior trim moldings and bumpers.



Part Number	Container Size	Containers Per Case
NEW 051131-38127	1 Gallon	4
NEW 051131-38128	5 Gallon Pail	1
NEW 051131-38129	55 Gallon Drum	1

## 3M™ Multi-Purpose Cleaner

3M™ Multi-Purpose Cleaner at 1 to 8 dilution, 1 part product to 8 parts water: cleans dirt, stains and soils from carpet and fabric, cleans heavily soiled leather upholstery. Use as a pre-spotter. Removes insect residue from vehicle exteriors. At 1 to 16 dilution, 1 part product to 16 parts water: cleans interior vinyls and plastics, cleans lightly soiled leather upholstery. 3M™ Multi-Purpose Cleaner is phosphate-free.



Part Number	Container Size	Containers Per Case
NEW 051131-38121	1 Gallon	4
NEW 051131-38122	5 Gallon Pail	1

# Cleaning

## 3M™ Interior Dressing

3M™ Interior Dressing is for use on interior vinyl, plastic and rubber surfaces. Produces a true color, natural gloss appearance.



Part Number	Container Size	Containers Per Case
NEW 051131-38086	1 Gallon	4
NEW 051131-38087	5 Gallon Pail	1

## 3M™ Detail Wax

3M™ Detail Wax is easy to use and produces a deep, rich, high-gloss, lustrous and durable “wet look” finish. Shines and protects and is clear coat safe.



Part Number	Container Size	Containers Per Case
NEW 051131-38111	1 Gallon	4

## 3M™ Gloss Enhancer

3M™ Gloss Enhancer is a spray detailing product that has a quick and easy “spray-on/wipe-off” application. Cleans, shines and adds depth to painted surfaces. Clear coat safe.



Part Number	Container Size	Containers Per Case
NEW 051131-38113	1 Gallon	4
NEW 051131-38114	5 Gallon Pail	1
NEW 051131-38115	55 Gallon Drum	1

## 3M™ Detail Polish 108

3M™ Detail Polish 108 is a light cutting, very fine finishing polish. Removes light oxidation, fine scratches and stains. Easy to use. Effective with wool and foam pads. Leaves an excellent high-gloss finish on all types of automotive paints. Clear coat safe.



Part Number	Container Size	Containers Per Case
NEW 051131-38133	1 Gallon	4

## 3M™ Detail Polish 208

3M™ Detail Polish 208 is a medium cutting, fine finishing polish. Removes light to medium oxidation and fine scratches. Easy to use. Effective with wool and foam pads. Leaves a high-gloss finish on all types of automotive paints. Clear coat safe.



Part Number	Container Size	Containers Per Case
NEW 051131-38116	1 Gallon	4

## 3M™ Detailing Squeeze Bottle

3M™ Detailing Squeeze Bottle is a 12-ounce ketchup-style bottle; includes spout top. Use for dispensing compounds, glazes, polishes and liquid wax.



Part Number	Description	Each Per Case
NEW 051131-37720	1 Bottle & Top	24

## 3M™ Solvent Spray Trigger Nozzle Head

3M™ Solvent Spray Trigger Nozzle Head is a long-lasting, adjustable sprayer that is excellent for 3M solvent-based products. For water-based 3M products, use 3M™ Detailing General Purpose Spray Trigger Nozzle Head (PN37717).



Part Number	Description	Each Per Case
NEW 051131-37718	1 Spray Head	24

## 3M™ Paint Preparation System

The 3M™ Paint Preparation System (PPS) is a new, innovative system for mixing and preparing refinish material prior to painting. The system is designed for gravity feed paint gun systems and its unique design can improve operator efficiency by as much as 15%. This can be gained while maintaining a healthier environment. The 3M™ Paint Preparation System replaces traditional paint mixing cups and filters, and drastically reduces the amount of solvent required for gun cleaning (up to 70% reduction in cleaning solvents). The 3M™ Paint Preparation System eliminates the need for separate mixing cups and filters. Instead, paint is mixed in a liner bag and direct filter, which is then mounted on the spray gun. The unique design allows the spray gun to function at any angle. Liner bags and filters are disposable, leaving only the spray gun and adapter to be cleaned. Adapters are available to convert all major spray guns and there are two sizes of cups and liners. The 3M™ Paint Preparation System is a cleaner, faster, healthier system, safe from outside contamination, and offers considerable time and solvent savings on gun and parts cleaning. The system is simple to use and demonstrate.

Part Number	Description	Each Per Box	Boxes Per Case
NEW 051131-16000	PPS Lids & Liners	50	1
NEW 051131-16001	PPS Cups and Collars	2	4
NEW 051131-16019	PPS Liner Dispenser	1	1
NEW 051131-16099	PPS Lid Dispenser	1	1
NEW 051131-37720	Detailing Squeeze Bottle	24	1

# Cleaning

## 3M™ Twist 'n Fill™ Cleaning Chemical Management System

The 3M™ Twist 'n Fill™ system features a single, compact dispenser that is designed to accurately mix and dispense a wide range of cleaning chemicals. The system dispenses chemicals with one compact dispenser. Unique bottle and cap design lets you interchange chemicals in seconds. Very compact; fits in any closet. Easy to use – just insert bottle, twist and fill! Integral air gap prevents chemical backflow. Flexible – mounts on wall or, for portability, on cart or cleaning equipment. Accurate dispensing technology ensures consistent, effective chemical performance. Automatic 3 gallon per minute dispense rate for bucket applications; 1 gallon per minute for trigger spray bottle applications. Automatic shut-off attachment also available. Tamper-resistant packaging helps control chemical mixing away from the dispenser.



	Part Number	Description	Dispensers Per Case
NEW	048011-23592	Cleaning Chemical Dispenser	1
NEW	048011-23593	Cleaning Chemical Dispenser	1

## 3M™ Heavy Duty Multi-Surface Cleaner

Versatile cleaner removes most spots, stains and grease from washable surfaces. Use to clean carpets, marble, aluminum, stainless steel, chrome, plastics, windows and mirrors.



	Part Number	Description	Each Per Case
NEW	048011-19202	Heavy Duty Multi-Surface Cleaner Concentrate	6

## 3M™ General Purpose Cleaner

High-performance, all-purpose cleaner. First choice for your everyday cleaning needs. Use to clean non-porous surfaces.



	Part Number	Description	Each Per Case
NEW	048011-19211	General Purpose Cleaner Concentrate	6

## 3M™ Glass Cleaner

Non-streaking cleaner for windows, glass and mirrors as well as stainless steel, chrome, aluminum, ceramic and plastic.



	Part Number	Description	Each Per Case
NEW	048011-23357	Glass Cleaner Concentrate	6

## 3M™ Heavy Duty Glass Cleaner

Non-streaking, heavy-duty cleaner for windows, glass, mirrors as well as stainless steel, chrome, aluminum, ceramic and plastic.



	Part Number	Description	Each Per Case
NEW	048011-23360	Heavy Duty Glass Cleaner Concentrate	6

## 3M™ 3-in-1 Cleaner

Versatile, low-foaming cleaner used for cleaning non-porous surfaces.



	Part Number	Description	Each Per Case
NEW	048011-23553	3-in-1 Floor Cleaner Concentrate	6

## Scotchgard™ Ultra Water Repellent with Mildew Block

Scotchgard™ Ultra Water Repellent with Mildew Block resists mildew growth and musty odors on the invisible coating. It has a fast-dry formula and seals with a durable water barrier. Repels rain, snow, stains and moisture. Keeps gear drier, cleaner and newer-looking longer. Won't change the look, feel or breathability of leather or fabrics.

	Part Number	Container Size	Containers Per Case
NEW	021200-52270	11 oz.	6

# Applications of 3M™ Preferred Marine Masking Tapes

Use this chart to select the right masking tape for the right application



Application	Scotch® Masking Tapes				Scotch® Paint Striping Tapes			Scotch® Weather Resistant Tapes					
	233+	233	2040	2070	218	256	471	225	226	481	2090	4811	
<b>Critical Paint Masking</b> (above waterline hull and top side/deck painting)			–							–		**	–
<b>Bottom Painting</b>				–						–		–	–
<b>Paint Striping/Color Separation</b> (boot, cove, shear or waterline stripe painting)	–	–	–					–	–	–	–	–	–
<b>Chemical Paint Stripping</b> (Caution is advised. Chemical stripper strengths vary.)	–	–	–	–	–	–	–	–			–	–	–
<b>Brightwork Finishing and Coating</b> (varnish, stain and sealing)			–									**	
<b>Outdoor Masking</b> (bundling and protecting over 24 hours)	–	–	–	–	–								
						Up to 5 Days	Up to 1 Mo.	Up to 1 Mo.	Up to 3 Mos.	Up to 2 Yrs.	Up to 7 Days	Up to 1 Yr.	

\* To use Scotch® No. 2070 3M™ Safe-Release™ Masking Tape for brightwork finishing and coating, follow this procedure:  
**Step 1.** First apply Scotch® No. 2070 3M™ Safe-Release™ Masking Tape as the “base” tape on fragile or delicate surfaces.  
**Step 2.** Apply appropriate masking tape, from Application/Selection Chart, directly over Scotch® No. 2070 Safe-Release™ Masking Tape and allow 1/16 in. to 1/8 in. overlap on leading edge. These steps provide safe removal from delicate surfaces and prevents edge seepage on leading edge.

\*\* Not recommended for use with lacquers or on lacquered surfaces.

	Product Number	Product
<b>Masking Tapes</b>	233+	Scotch® Paint Masking Tape
	233	Scotch® Paint Masking Tape
	2040	Scotch® Masking Tape
	2070	Scotch® Safe-Release™ Masking Tape
<b>Paint Striping Tapes</b>	218	Scotch® Fine Line Tape
	256	3M™ ScotchMark™ Green Masking Tape
	471	Scotch® Plastic Tape
<b>Weather Resistant Tapes</b>	225	Scotch® Silver Weather Resistant Masking Tape
	226	Scotch® Solvent Weather Resistant Masking Tape
	481	Scotch® Black Preservation Tape
	2090	Scotch® Long-Mask™ Masking Tape
	4811	Scotch® White Preservation Tape

# Masking Tapes

## Scotch® Paint Masking Tape — No. 233+

This highly conformable tape provides outstanding paint lines. It consistently performs under a variety of climactic conditions.



Part Number	Size (metric)	Rolls Per Case
051131-26330	6mm x 55m (1/4 inch applications)	96
051131-26332	12mm x 55m (1/2 inch applications)	48
051131-26334	18mm x 55m (3/4 inch applications)	48
051131-26335	21mm x 55m (7/8 inch applications)	40
051131-26336	24mm x 55m (1 inch applications)	24
051131-26338	36mm x 55m (1-1/2 inch applications)	16
051131-26340	48mm x 55m (2 inch applications)	12
051131-26341	72mm x 55m (3 inch applications)	8
051131-26343	3mm x 55m (1/8 inch applications)	12
051131-26344	6mm x 55m (1/4 inch applications)	12
051131-26346	12mm x 55m (1/2 inch applications)	12

## Scotch® Paint Masking Tape — No. 233

Designed specifically for the professional painter, this tape is conformable, hugs curves and contours, goes on quick and easy, sticks at a touch and stays put. Well suited for boats, trucks and aircraft. Not for extended outdoor use.

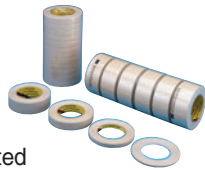

Part Number	Size	Rolls Per Case
021200-06330	1/4" x 60 yds.	144
021200-06332	1/2" x 60 yds.	72
021200-06334	3/4" x 60 yds.	48
021200-06335	7/8" x 60 yds.	48
021200-06336	1" x 60 yds.	36
021200-06338	1-1/2" x 60 yds.	24
021200-06340	2" x 60 yds.	24
021200-06341	3" x 60 yds.	12
021200-06343	1/8" x 60 yds. Bxd.	12
021200-06344	1/4" x 60 yds. Bxd.	12
021200-06346	1/2" x 60 yds. Bxd.	12

## Scotch® Masking Tape — No. 2040

A professional painter's grade masking tape that gives good protection yet removes cleanly and easily. Not for extended outdoor use.



Part Number	Size	Rolls Per Case
021200-02991	18mm x 55m	48
021200-02992	24mm x 55m	36
021200-02993	36mm x 55m	24
021200-04365	48mm x 55m	24
021200-02994	72mm x 55m	12

## Scotch® Safe-Release™ Masking Tape — No. 2070

Scotch® Safe-Release™ Masking Tape — No. 2070 is a white-colored, flat-back paper masking tape utilizing a low-tack adhesive system that provides safe removal without damage to delicate surfaces. This tape should be used in place of higher tack masking tapes if the risk of "lifting" or pulling up of an existing finish (paint or varnish) is possible. Can also be used as a paint striping masking tape, providing sharp paint lines.



Part Number	Size	Rolls Per Case
051115-02501	3/4" x 60 yds.	24
051115-00445	1" x 60 yds.	24
051115-02502	1-1/2" x 60 yds.	12
051115-00444	2" x 60 yds.	12

## Scotch® Painter's Masking Tape — No. 212

Designed for non-critical paint masking. Not for extended outdoor use.



Part Number	Size	Rolls Per Case
021200-08032	3/4" x 60 yds.	48
021200-08034	1" x 60 yds.	36
021200-08035	1-1/2" x 60 yds.	24
021200-04230	2" x 60 yds.	24

## Scotch® Masking Tape — No. 2050

A general purpose masking or binding tape.



Part Number	Size	Rolls Per Case
021200-05617	.70" x 2160"	48
021200-05618	.94" x 2160"	36
021200-05619	1.41 x 2160"	24
021200-05620	1.88 x 2160"	24
021200-05621	2.83" x 2160"	12

## Scotch® Mold Release Masking Tape — No. 249

A high-performance masking tape specifically designed for applications where the substrate to be masked has extremely low surface energy. A primary application is masking fiberglass molds prior to production.



Part Number	Size	Rolls Per Case
051131-06357	1/4" x 60 yd.	96
051131-06359	3/4" x 60 yd.	32
051131-06363	2" x 60 yd.	12

# Paint Striping Tapes

## Scotch® Fine Line Tape — No. 218

This specially extruded matte finish green polypropylene tape provides the finest color line separation available because of its thinness. Stretches easily for smooth curves — yet tears easily by hand. Excellent solvent and moisture resistance. Allows taping over freshly cured lacquer, enamel and urethane paint systems sooner with less chance of imprint damage. Not for extended outdoor use.

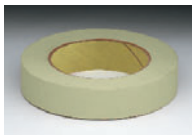

Part Number	Size	Rolls Per Case
021200-06300	1/8" x 60 yds. Bxd.	12
021200-06301	1/4" x 60 yds. Bxd.	12
021200-06302	3/8" x 60 yds. Bxd.	12
021200-06303	1/2" x 60 yds. Bxd.	12
021200-06305	3/4" x 60 yds. Bxd.	12
021200-06306	1/16" x 60 yds. Bxd.	12
021200-06307	3/16" x 60 yds. Bxd.	12
021200-06308	3/32" x 60 yds. Bxd.	12
021200-16028	1/4" x 60 yds. Bulk	144
021200-04698	1/2" x 60 yds. Bulk	72
021200-04699	3/4" x 60 yds. Bulk	48
021200-04700	1" x 60 yds. Bulk	36
021200-04701	2" x 60 yds. Bulk	24

## Scotch® Fine Line Paint Striping Tape — No. 218

A specially engineered tape that is slit to provide pull-out pieces for paint striping. Scotch® Fine Line Paint Striping Tape can be applied over freshly painted acrylic lacquer or enamel surfaces sooner and with less chance of imprinting. This polypropylene film tape is excellent for multicolor striping applications. Not for extended outdoor use.



Part Number	Size	Number of Pull-outs	Rolls Per Case
021200-06312	1" x 550"	2 pull-outs 1/16" & 3/32"	12
021200-06314	1" x 550"	8 pull-outs 1/16" each	12

## 3M™ ScotchMark™ Green Masking Tape — No. 256

A treated, flatback tape with good adhesive characteristics and a surface color-coating of light green. Has a smooth, sharp edge and doesn't lose its shape when applied over a long, continuous horizontal surface such as masking for painting of a boat's boot stripe. Has time limits when exposed to ultraviolet.

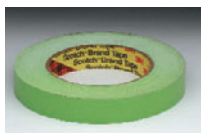

Part Number	Size	Rolls Per Case
021200-05423	3/4" x 60 yds.	48
021200-04968	1" x 60 yds.	36

## Scotch® Plastic Tape — No. 471, Blue

A blue vinyl plastic tape that is highly conformable and is excellent for masking off areas for detailed boat and boot stripe painting. Also excellent for masking over rivets or aluminum boats.



Part Number	Size	Rolls Per Case
051131-06404	1/8" x 36 yds. Bxd.	12
021200-06405	1/4" x 36 yds. Bxd.	12
051131-06408	1/2" x 36 yds. Bxd.	12
051131-06409	3/4" x 36 yds. Bxd.	12
021200-61192	1/4" x 36 yds. Bulk	144
021200-03119	1/2" x 36 yds. Bulk	72
021200-03120	3/4" x 36 yds. Bulk	48
021200-03121	1" x 36 yds. Bulk	36

## Scotch® Paint Striping Tape — No. 471, Blue

Scotch® Paint Striping Tape makes painting on pinstripes fast and easy. It comes in ten of the OEM's most popular painted on pinstripe sizes. Scotch® Paint Striping Tapes premask and liner make for easy application. #471 Scotch® Blue Plastic Tape makes sharp, clean edges and is easily removed. All rolls are 40 ft. long.



Part Number	Pinstripe Sizes	Roll Length	Rolls Per Case
051131-06315	1/16" space 1/16" #471 Blue 1/16" space	40'	12
051131-06316	1/16" space 3/16" #471 Blue 3/16" space	40'	12
051131-06317	1/16" space 3/32" #471 Blue 3/32" space	40'	12
051131-06318	1/16" space 1/8" #471 Blue 1/8" space	40'	12
051131-06319	1/8" space 1/8" #471 Blue 1/8" space	40'	12
051131-06320	1/16" space 1/8" #471 Blue 3/16" space	40'	12
051131-06322	1/16" space 1/16" #471 Blue 3/32" space	40'	12
051131-06323	1/16" space 1/8" #471 Blue 1/16" space	40'	12
051131-06324	1/8" space 1/16" #471 Blue 1/8" space	40'	12
051131-06325	3/32" space 1/8" #471 Blue 3/32" space	40'	12



# Weather Resistant Tapes

## Scotch® Silver Weather Resistant Masking Tape — No. 225

The silver colored coating on the backing of this crepe paper tape reflects ultraviolet (U.V.) light to provide weather resistance for up to a month's time. Prevents slivering and adhesive transfer during unmasking.

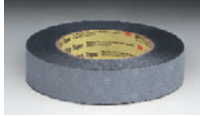

Part Number	Size	Rolls Per Case
021200-02828	3/4" x 60 yds.	48
021200-02829	1" x 60 yds.	36
021200-02830	1-1/2" x 60 yds.	24
021200-04597	2" x 60 yds.	24

## Scotch® Black Preservation Tape — No. 481

A pigmented black plastic film tape that conforms readily to irregular surfaces and has excellent stain resistance. Resists hot and cold weathering over two years. Removes cleanly and quickly. Uses include holding and sealing poly and other covering material to sides of boats during storage and shipment.

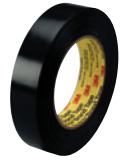

Part Number	Size	Rolls Per Case
021200-03174	1" x 36 yds.	36
021200-04319	2" x 36 yds.	24
021200-03175	3" x 36 yds.	12

## Scotch® Solvent Weather Resistant Masking Tape — No. 226

A black polyethylene crepe paper tape with high solvent resistance, excellent outdoor weathering properties (up to 3 months), strong adhesion and conformability for boat repair. Also applicable when using chemical strippers on wooden boats, teak decks, teak surrounding brightwork of cabins, as well as other painted surfaces.



Part Number	Size	Rolls Per Case
021200-61173	3/4" x 60 yds.	48
021200-61174	1" x 60 yds.	36
021200-61176	2" x 60 yds.	24
021200-61177	3" x 60 yds.	12

## Scotch® White Preservation Tape — No. 4811

Scotch® White Preservation Tape — No. 4811 is a white, pressure-sensitive tape designed for use in sealing of plastic sheeting, tarps, and shrinkwrap for boat storage and over-the-road transportation. Applies well in cold weather and is resistant to hot and cold temperatures. Is also resistant to common lubricants and strippable coatings. Removes cleanly and easily up to two years after application when properly applied.



Part Number	Size	Rolls Per Case
021200-62334	2" x 36 yds.	24
021200-62335	3" x 36 yds.	12

## Scotch® Long-Mask™ Masking Tape — No. 2090

Scotch® Long-Mask™ Masking Tape — No. 2090 utilizes a synthetic adhesive system which provides ultraviolet (U.V.) stability and adhesive transfer resistance up to seven days after application. Controlled crepe paper backing makes tape conformable and smooth for use in various paint, varnish masking applications. Bright blue color makes this tape easily identifiable.



Part Number	Size	Rolls Per Case
051115-06817	3/4" x 60 yds.	48
051115-06818	1" x 60 yds.	36
051115-06819	1-1/2" x 60 yds.	24
051115-06820	2" x 60 yds.	24

# Painting Tape

## Scotch® Ready-Mask™ Painting Tape

An easy to apply painting tape which protects surfaces from paint splattering and overspray. Comes off clean with no adhesive transfer. Paint will not seep through.



Part Number	Size	Rolls Per Case
051131-62691	3" x 133-1/3 yds. (400 ft)	8
051131-62692	3-3/4" x 25 yds. (75 ft)	12
051131-62693	2" x 60 yds. (180 ft)	12

## 3M™ Scotch® Brand Safe-Release™ Painters Masking Tape 2080

This tape removes cleanly without adhesive transfer or surface damage for up to 60 days — even in direct sunlight. It is a low-medium adhesion tape that is ideal for smooth, freshly painted surfaces, striping, vinyl coated wallpaper and glass.



Part Number	Size	Rolls Per Case
NEW 051131-80988	3/4" x 60 yds.	48
NEW 051131-79748	1" x 60 yds.	36
NEW 051131-79749	1-1/2" x 60 yds.	24
NEW 051131-79750	2" x 60 yds.	24

# Protective and Chafing Tapes

## Scotch® Protective Tape

A tough paper-backed tape designed to protect sections of boats and boat boot stripes during sanding and light sandblasting.



Part Number	Size	Rolls Per Case
021200-06945	2" x 20 yds.	12

## 3M™ Marine Heavy Duty Protection Tape — No. 346

3M™ Marine Heavy Duty Protection Tape — No. 346 is abrasion resistant; its 17 mil thickness gives outstanding protection against scuffing and tearing. It offers protection to topside surfaces and cabin soles of boats under construction or repair/restoration. Its adhesive transfer resistance makes it ideal for use wherever protection from wear or damage is needed; as a temporary carpet for new boat display, to protect plastic portlites and windshields from scratches during installation, prevents damage to painted, varnished, gelcoated surfaces, wooden decks or fiberglass decks.

Part Number	Size	Rolls Per Case
021200-05418	12" x 60 yds.	4
021200-05419	18" x 60 yds.	1
021200-05420	24" x 60 yds.	1
021200-05421	36" x 60 yds.	1

## Scotch® Aluminum Foil Tape — No. 425

A dead soft foil tape with a highly reflective backing that provides excellent radiation for both heat and light. Used as a mask or protective surface in paint stripping operations, as well as in electroplating. Also used for general sealing, metal patching, moisture barrier and heat reflecting. Long aging both indoor and outdoors.



Part Number	Size	Rolls Per Case
021200-07689	1/2" x 60 yds. Bxd.	12
021200-05797	3/4" x 60 yds. Bxd.	12
021200-07690	1" x 60 yds. Bxd.	12
021200-60596	1/2" x 60 yds. Bulk	72
021200-60600	3/4" x 60 yds. Bulk	48
021200-60572	1" x 60 yds. Bulk	36
021200-60574	2" x 60 yds. Bulk	24
021200-60597	3" x 60 yds. Bulk	12

## Scotch® Plastic Chafing Tape — No. 471, White

A white vinyl plastic tape that is highly conformable and withstands heavy abrasion. It is commonly used in marine as a chafing tape to protect dock, mooring and rigging lines, turn buckles, shrouds and spreaders. Not recommended for use on vinyl or other plastics containing migrating-type plasticizers.



Part Number	Size	Rolls Per Case
021200-03135	3/4" x 36 yds.	48
021200-03136	1" x 36 yds.	36

# 3M Marine/RV Surface Protection Products

Film Backed Products							Surface to be Protected												
UPC	3M Product Number	Roll Size (English)	Color	Thickness (mils)	OK for Outdoor Use	Rolls Per Case	Carpet	Gelcoat – Diamond Patterned Nonskid	Gelcoat	Glass – Windshields	Hatches Plexiglass™	Indoor Mirrors	Wood Cabinets	Countertop (Gloss)	Countertop (Matte)	Countertop (Corian™)	Stainless Steel / Railings	Dashboards	Interior Fabric
021200	49448	2E93-EZ-M	24" x 150'	Clear	2	No	1												
021200	49449	2E95-EZ-M	24" x 150'	Clear	2	No	1												
021200	49450	25A26-M	12" x 150'	Blue	2	No	2												
021200	49451	25A26-M	24" x 150'	Blue	2	No	1												
021200	49452	25A88-M	12" x 150'	Clear	2	No	2												
021200	49453	3W26X-M	6" x 150'	Black/White	3	Yes	4												
021200	49454	3W26X-M	12" x 150'	Black/White	3	Yes	2												
021200	49455	3W26X-M	24" x 150'	Black/White	3	Yes	1												
021200	49456	3110-M	6" x 150'	Clear	3	No	4												
021200	49457	3110-M	12" x 150'	Clear	3	No	2												
021200	49458	3110-M	24" x 150'	Clear	3	No	1												
021200	49459	3125-M	6" x 150'	White	3	No	4												
021200	49460	3125-M	12" x 150'	White	3	No	2												
021200	49461	3125-M	24" x 150'	White	3	No	1												
021200	49462	3126-M	6" x 150'	Clear	3	No	4												
021200	49463	3126-M	12" x 150'	Clear	3	No	2												
021200	49464	3179-M	12" x 150'	Clear	3	No	2												
021200	49465	3179-M	24" x 150'	Clear	3	No	1												
021200	49466	4125-M	12" x 150'	Clear	4	No	2												
021200	49467	4125-M	24" x 150'	Clear	4	No	1												
021200	55458	4130C/ZC20-M	6" x 150'	Clear	4	Yes	8												
021200	55459	4130C/ZC21-M	8" x 150'	Clear	4	Yes	6												
021200	55460	4130C/ZC20-M	6" x 150'	Clear	4	Yes	8												
021200	55461	4130C/ZC21-M	8" x 150'	Clear	4	Yes	6												
021200	49468	4187-M	6" x 150'	Clear	4	No	4												
021200	49469	4187-M	12" x 150'	Clear	4	No	2												
021200	49470	4187-M	24" x 150'	Clear	4	No	1												
021200	49471	4193-M	12" x 150'	Clear	4	No	2												
021200	49472	4193-M	24" x 150'	Clear	4	No	1												
021200	49473	5A29-M	6" x 150'	Clear	5	No	4												
021200	49474	5A29-M	12" x 150'	Clear	5	No	2												
021200	49475	5A29-M	24" x 150'	Clear	5	No	1												
021200	49476	5126-M	6" x 150'	Clear	5	No	4												
021200	49477	5126-M	12" x 150'	Clear	5	No	2												
021200	49478	5126-M	24" x 150'	Clear	5	No	1												
021200	49479	64S58-M	12" x 150'	White	6	No	2												
021200	49480	64S58-M	24" x 150'	White	6	No	1												
051128	74779	SCPM 44X	12" x 100 yds.	Tan	6	No	1												
051128	74780	SCPM 44X	16" x 100 yds.	Tan	6	No	1												
051128	30379	SCPM 44X	24" x 100 yds.	Tan	6	No	1												
051128	30378	SCPM 44X	36" x 100 yds.	Tan	6	No	1												
051128	30377	SCPM 44X	48" x 100 yds.	Tan	6	No	1												
021200	05418	#346	12" x 60 yds.	Tan	17	No	4												
021200	05419	#346	18" x 60 yds.	Tan	17	No	1												
021200	05420	#346	24" x 60 yds.	Tan	17	No	1												
021200	05421	#346	36" x 60 yds.	Tan	17	No	1												

■ = Recommended Product Choice

# Protective and Chafing Tapes

## Number Identification System

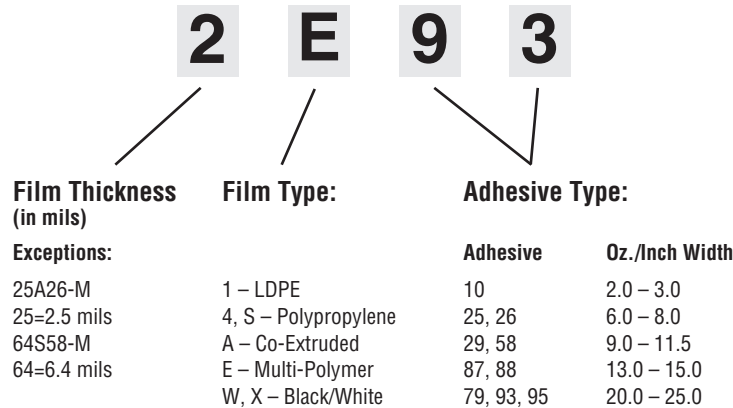

### 3M™ Marine Protective Carpet Tape 2E93-EZ-M — Clear

Suggested use: Temporary protection of carpet-interior, non-Scotchguarded and interior-fabrics.

Part Number	Product Number	Size	Rolls Per Case
NEW 021200- <b>49448*</b>	2E93-EZ-M	24" x 150'	1

\* Replaces 3M™ Marine Protective Tape 1100 (051131-05431).

### 3M™ Marine Co-Extruded Polyethylene Protective Tape 25A88-M — Clear

Suggested use: Temporary protection of counter tops – matte laminate.

Part Number	Product Number	Size	Rolls Per Case
NEW 021200- <b>49452</b>	25A88-M	12" x 150'	2

### 3M™ Marine Protective Carpet Tape 2E95-EZ-M — Clear

Suggested use: Temporary protection of carpet-interior, Scotchguarded and interior-fabrics.

Part Number	Product Number	Size	Rolls Per Case
NEW 021200- <b>49449*</b>	2E95-EZ-M	24" x 150'	1

\* Replaces 3M™ Marine Protective Tape 1100 (051131-05431).

### 3M™ Marine Outdoor Polyethylene Protective Tape 3W26X-M — Black/White

Suggested use: Temporary protection of glass – windshields (UV), hatches and Plexiglass™, plastics – gelcoat/fiberglass and metals – painted, stainless steel rails/hardware.

Part Number	Product Number	Size	Rolls Per Case
NEW 021200- <b>49453*</b>	3W26X-M	6" x 150'	4
NEW 021200- <b>49454*</b>	3W26X-M	12" x 150'	2
NEW 021200- <b>49455*</b>	3W26X-M	24" x 150'	1

\* Replaces 3M™ Marine Protective Tape 1200 and 1200H (051131-05432, 051131-05433, 051131-05434, 051131-05435, 051131-05436 and 051131-05437).

### 3M™ Marine Co-Extruded Polyethylene Protective Tape 25A26-M — Blue

Suggested use: Temporary protection of counter tops – gloss laminate and Corian™, and wood floors – urethane coated.

Part Number	Product Number	Size	Rolls Per Case
NEW 021200- <b>49450</b>	25A26-M	12" x 150'	2
NEW 021200- <b>49451</b>	25A26-M	24" x 150'	1

### 3M™ Marine Polyethylene Protective Tape 3110-M — Clear

Suggested use: Temporary protection of glass – mirrors (indoor) and dashboards.

Part Number	Product Number	Size	Rolls Per Case
NEW 021200- <b>49456</b>	3110-M	6" x 150'	4
NEW 021200- <b>49457</b>	3110-M	12" x 150'	2
NEW 021200- <b>49458</b>	3110-M	24" x 150'	1

# Protective and Chafing Tapes

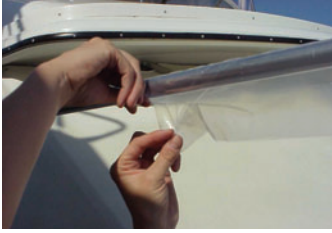

## 3M™ Marine Polyethylene Protective Tape 3125-M — White

Suggested use: Temporary protection of plastics – gelcoat/fiberglass, counter tops – gloss laminate.

Part Number	Product Number	Size	Rolls Per Case
NEW 021200-49459	3125-M	6" x 150'	4
NEW 021200-49460	3125-M	12" x 150'	2
NEW 021200-49461	3125-M	24" x 150'	1

## 3M™ Marine Polyethylene Protective Tape 4193-M — Clear

Suggested use: Temporary protection of carpet – interior, Scotchguarded, and fabrics – interior.

Part Number	Product Number	Size	Rolls Per Case
NEW 021200-49471	4193-M	12" x 150'	2
NEW 021200-49472	4193-M	24" x 150'	1

## 3M™ Marine Polyethylene Protective Tape 3126-M — Clear

Suggested use: Temporary protection of counter tops – gloss Corian™, and metal – stainless steel rails/hardware.

Part Number	Product Number	Size	Rolls Per Case
NEW 021200-49462	3126-M	6" x 150'	4
NEW 021200-49463	3126-M	12" x 150'	2

## 3M™ Marine Co-Extruded Polyethylene Protective Tape 5A29-M — Clear

Suggested use: Temporary protection of wood cabinets and glass – mirrors (indoor).

Part Number	Product Number	Size	Rolls Per Case
NEW 021200-49473	5A29-M	6" x 150'	4
NEW 021200-49474	5A29-M	12" x 150'	2
NEW 021200-49475	5A29-M	24" x 150'	1

## 3M™ Marine Polyethylene Protective Tape 3179-M — Clear

Suggested use: Temporary protection of carpet – interior, Scotchguarded, and fabrics – interior.

Part Number	Product Number	Size	Rolls Per Case
NEW 021200-49464*	3179-M	12" x 150'	2
NEW 021200-49465*	3179-M	24" x 150'	1

\* Replaces 3M™ Marine 1300 Protective Tape (051131-05438).

## 3M™ Marine Polyethylene Protective Tape 5126-M — Clear

Suggested use: Temporary protection of wood cabinets and glass – mirrors (indoor).

Part Number	Product Number	Size	Rolls Per Case
NEW 021200-49476	5126-M	6" x 150'	4
NEW 021200-49477	5126-M	12" x 150'	2
NEW 021200-49478	5126-M	24" x 150'	1

## 3M™ Marine Polyethylene Protective Tape 4125-M — Clear

Suggested use: Temporary protection of glass – mirrors (indoor).

Part Number	Product Number	Size	Rolls Per Case
NEW 021200-49466	4125-M	12" x 150'	2
NEW 021200-49467	4125-M	24" x 150'	1

## 3M™ Marine Polyethylene Protective Tape 64S58-M — White

Suggested use: Temporary protection of glass – windshields (UV).

Part Number	Product Number	Size	Rolls Per Case
NEW 021200-49479	64S58-M	12" x 150'	2
NEW 021200-49480	64S58-M	24" x 150'	1

## 3M™ Marine Polyethylene Protective Tape 4187-M — Clear

Suggested use: Temporary protection of plastics – gelcoat (high dust).

Part Number	Product Number	Size	Rolls Per Case
NEW 021200-49468	4187-M	6" x 150'	4
NEW 021200-49469	4187-M	12" x 150'	2
NEW 021200-49470	4187-M	24" x 150'	1

# Protective and Chafing Tapes

## 3M™ Easy Tear Protective Railing Tape 4130C/ZC

Clear, 4-mil protective tape coated on each edge with a non-coated area in the middle. A continuous perforation near one edge allows for easy removal. Use for temporary protection of stainless steel rails, stanchions and other cylindrical boat parts.

	Part Number	Description	Size	Rolls Per Case
NEW	021200-55458	Second perforation every 6 inches across tape – easy tearing off of the roll	6" x 150'	8
NEW	021200-55459	Second perforation every 6 inches across tape – easy tearing off of the roll	8" x 150'	6
NEW	021200-55460	No cross tape perforation	6" x 150'	8
NEW	021200-55461	No cross tape perforation	8" x 150'	6

## 3M™ Protective Tape SCPM 44X

A 6-mil, medium-high tack protective tape with anti-slip properties. Applications include protecting aggregate and diamond patterned non-skid, gel-coat, paint, wood and counter top surfaces during boat or RV assembly and repair processes. For indoor use only.

	Part Number	Size	Rolls Per Case
NEW	051128-74779	12" x 100 yd.	1
NEW	051128-74780	16" x 100 yd.	1
NEW	051128-30379	24" x 100 yd.	1
NEW	051128-30378	36" x 100 yd.	1
NEW	051128-30377	48" x 100 yd.	1

## 3M™ Scotch® 300 Series Barricade Tapes

The 3M™ Scotch® 300 Series Barricade Tapes are not only effective but also economical as well with 300 and 1000 feet of tape per roll. One roll has sufficient length to designate a large area. It is constructed of durable polyethylene plastic and measures 3 or 4 mil thick, which prevents accidental tearing. Bold, two-inch, black characters on a bright yellow or red background are sure to attract attention and ensure that a warning message is clearly visible. The Scotch® 300 Series Barricade Tapes are non-adhesive, non-lead, polyethylene tapes. The tapes are a fast, effective way to restrict entry into hazardous areas. "Caution" is printed repeatedly in bold, black characters on a bright yellow or red background. The roll dimensions are 3" x 1000' or 3" x 300' with a nominal 3 or 4-mil thickness. Each roll is individually shrink-wrapped.



	Part Number	Size	Rolls Per Case
NEW	055128-53042	3" x 1000'	8
NEW	051128-53460	3" x 300'	16

# Duct and Cloth Tapes

## Scotch® Heavy Duty Cloth Duct Tape

A strong general purpose mending, bundling and protective tape.



Part Number	Tape Number	Size	Rolls Per Case
051131- <b>50252</b>	131	48mm x 9.1m	24
051131- <b>50253</b>	132	48mm x 18.2m	24
051131- <b>50254</b>	133	48mm x 54.8m	24

## Scotch® Cloth Tape — No. 393

A polyethylene coated cloth tape used for sealing joints of hot and cold air ducts and dust collecting systems. Ideal moisture barrier for sealing butt joints on both rigid and flexible insulation material. Excellent general purpose mending and bundling tape. Silver gray in color.

Part Number	Size	Rolls Per Case
021200- <b>03027</b>	2" x 60 yds.	24

## 3M™ Vinyl Duct Tape 3903

A general purpose vinyl duct tape designed for non-critical applications such as sealing, bundling, holding and various miscellaneous applications.

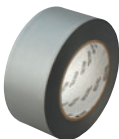

Part Number	Size	Color	Rolls Per Case
051131- <b>06984</b>	2" x 50 yds.	Gray	24
051131- <b>06995</b>	2" x 50 yds.	Black	24

## Highland™ Cloth Duct Tape

Highland™ Cloth Duct Tape is a general purpose cloth duct tape designed for non-critical applications such as sealing, bundling, holding, and various miscellaneous applications.

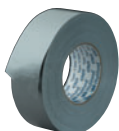

Part Number	Size	Color	Rolls Per Case
051131- <b>06969</b>	48mm x 54.8m	Silver	24

## Tartan™ Silver Duct Tape — No. 3939

Tartan™ Silver Duct Tape is designed for general purpose use in bundling, sealing and holding applications.

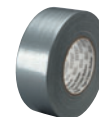

Part Number	Size	Color	Rolls Per Case
051131- <b>06975</b>	48mm x 54.8m	Silver	24

## Tartan™ Color Cloth Tape

Tartan™ Color Cloth Tape is an economical 9 mil thick tape constructed of polyethylene film bonded to a strong polycotton blend cloth. This tape is conformable and also provides good weather and moisture resistance. Available in assorted colors for mending vinyl seatcushions, canvas boat covers, plastic tarps, etc. Available in two roll sizes: 48mm x 9.1m and 48mm x 45.8m.



Part Number	Catalog Number	Color	Size	Rolls Per Case
051131- <b>58708</b>	330	Yellow	48mm x 54.8m	12
051131- <b>58709</b>	330	Black	48mm x 54.8m	12
051131- <b>58710</b>	330	Green	48mm x 54.8m	12
051131- <b>58711</b>	330	Blue	48mm x 54.8m	12
051131- <b>58727</b>	330	Brown	48mm x 54.8m	12
051131- <b>58728</b>	330	Red	48mm x 54.8m	12
051131- <b>58729</b>	330	White	48mm x 54.8m	12
051131- <b>58720</b>	329	White	48mm x 9.1m	12
051131- <b>58721</b>	329	Yellow	48mm x 9.1m	12
051131- <b>58722</b>	329	Black	48mm x 9.1m	12
051131- <b>58723</b>	329	Green	48mm x 9.1m	12
051131- <b>58724</b>	329	Blue	48mm x 9.1m	12
051131- <b>58725</b>	329	Red	48mm x 9.1m	12
051131- <b>58726</b>	329	Brown	48mm x 9.1m	12

# Box Sealing Tapes

## 3M™ Scotchpro™ Box Sealing Tape — No. 3750

A strong film tape that is excellent for box sealing, recoupage, fiber drum sealing and other heavy duty packaging applications. Available in transparent and tan colors.



Part Number	Size (metric)	Color	Rolls Per Case
051131- <b>06639</b>	36mm x 50m	Transparent	36
051131- <b>06640</b>	48mm x 50m	Transparent	36
051131- <b>06641</b>	36mm x 50m	Tan	36
051131- <b>06642</b>	48mm x 50m	Tan	36

## Scotch® 3750-DD-Box Sealing Tape w/Disposable Dispenser

Scotch® 3750-DD is the same "Scotchpro™" High Performance Box Sealing Tape but mounted in its own red disposable dispenser. This disposable dispenser makes it extremely convenient to use in a variety of locations without making an investment in extra dispensers.



Part Number	Size (metric)	Color	Rolls Per Case
051131- <b>06647</b>	48mm x 50m	Tan	24
051131- <b>06648</b>	48mm x 50m	Transparent	24

## Scotch® 3750-RD Box Sealing Tape with Reusable Dispenser

Scotch® 3750-RD is the same "Scotchpro™" High Performance Box Sealing Tape but mounted in its own red reusable dispenser. This reusable dispenser makes it extremely convenient to use in a variety of locations without making an investment in extra dispensers.



Part Number	Size (metric)	Color	Rolls Per Case
021200- <b>39523</b>	48mm x 50m	Transparent	24
021200- <b>39524</b>	48mm x 50m	Tan	24

## Tartan™ General Purpose Box Sealing Tape — No. 3690

A utility grade film designed for light-duty box sealing applications.



Part Number	Size (metric)	Color	Rolls Per Case
021200- <b>82862</b>	48mm x 50m	Tan	36
021200- <b>82864</b>	48mm x 50m	Transparent	36
021200- <b>82863</b>	48mm x 100m	Tan	36
021200- <b>82865</b>	48mm x 100m	Transparent	36

## Highland™ Commercial Grade Box Sealing Tape — No. 3710

A strong film tape that conforms to box surfaces for a consistent uniform seal with no water or sticky cleanup. Resists center seam splitting and seals out moisture, dust and dirt. Ideal for most packaging needs.



Part Number	Size (metric)	Color	Rolls Per Case
021200- <b>14765</b>	48mm x 50m	Tan	36
021200- <b>14766</b>	48mm x 50m	Transparent	36
021200- <b>18813</b>	48mm x 100m	Transparent	36
021200- <b>18814</b>	48mm x 100m	Tan	36



# Filament Strapping Tape

## Scotch® Transparent Filament Tape — No. 898

Excellent for bundling elongated metal and wood parts and for sealing and reinforcing cartons containing heavy items for shipment. Strong – High performance – Adheres instantly. Tensile strength is 380 lbs./inch.



Part Number	Size (metric)	Rolls Per Case
051131-06893	12mm x 55m (Bxd.)	12
051131-06894	18mm x 55m (Bxd.)	12
051131-06895	24mm x 55m (Bxd.)	12
051131-06896	12mm x 55m (Bulk)	72
051131-06897	18mm x 55m (Bulk)	48
051131-06898	24mm x 55m (Bulk)	36

## Scotch® Filament Tape — No. 893

An economical transparent filament tape for general and miscellaneous packaging. Tensile strength is 300 lbs./inch.



Part Number	Size (metric)	Rolls Per Case
051131-06937	12mm x 55m (Bulk)	72
051131-06938	18mm x 55m (Bulk)	48
051131-06939	24mm x 55m (Bulk)	36

## Highland™ Filament Tape — No. 897

A commercial grade filament tape for use when a medium-duty reinforced tape is required.



Part Number	Size (metric)	Rolls Per Case
021200-86523	12mm x 55m	72
021200-86524	18mm x 55m	48
021200-86525	24mm x 55m	36

## Tartan™ Strapping Tape — No. 8934

General purpose strapping tape designed for light-duty strapping applications such as reinforcing boxes and bundling light items.



Part Number	Size (metric)	Rolls Per Case
021200-86518	12mm x 55m	72
021200-86519	18mm x 55m	48
021200-86520	24mm x 55m	36

# Packaging Tape Bonus Packs

## Packaging Tape Bonus Packs

Scotch® and Highland™ Bonus Packs are designed with quality tapes and dispensers to meet your customer's packaging needs. They are value-added items saving both time and money.



Part Number	Description	Packs Per Case
051131-06634	12 Rolls Scotch® #3750 Box Sealing Tape 48mm x 50m with H-122 Dispenser (BP-5)	3
051131-06635	12 Rolls Scotch® #3750 Clear Box Sealing Tape 48mm x 50m with H-122 Dispenser (BP-6)	3

# General Purpose Tapes

## Tartan™ Paper Tape — No. 200

A utility purpose paper tape used for holding, bundling and sealing. Ideal for paint suit sleeve and shoe wrapping. Not to be used for paint masking.



Part Number	Size	Rolls Per Case
021200-71177	48mm x 55m	24
021200-71179	36mm x 55m	24
021200-71180	24mm x 55m	36
021200-71182	18mm x 55m	48

## 3M™ Paper Masking Tape — No. 2214

This is a general purpose tape for holding, bundling, sealing, non-critical masking and a vast number of other jobs where a pressure-sensitive tape is needed.

Part Number	Size	Rolls Per Case
021200-45587	12mm x 55m	64
021200-26074	18mm x 55m	64
021200-26075	24mm x 55m	64
021200-26076	36mm x 55m	64
021200-26077	48mm x 55m	48
021200-26078	72mm x 55m	64
021200-48119	96mm x 55m	64

## Scotch® Transparent Tape — No. 600

An economical general purpose tape with a wide range of uses. This crystal clear, non-yellowing transparent tape can be used for a variety of sealing, protecting and holding applications.



Part Number	Size	Rolls Per Case
021200-06941	3/8" x 72 yds.	12
051131-06821	1/2" x 72 yds.	12
021200-06943	3/4" x 72 yds.	12

## Post-it® Removable Labeling Tape — No. 695

General purpose removable marking tape which can be used for labeling bin and shelf marking, package identification and correction and coverup work. Sticks firmly yet removes easily.

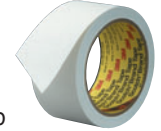

Part Number	Size	Rolls Per Case
051131-06950	3/4" x 36" yds.	48
051131-06951	2" x 36 yds.	24

# Packing List Tapes

## Scotch® Labelgard™ Tape — No. 8210

Scotch® Labelgard™ Tape is designed for the attachment and protection of address labels on a wide variety of shipping and mailing containers.



Part Number	Size	Rolls Per Case
021200-06888	4" x 72 yds.	8
021200-06889	- No Longer Available -	

## Scotch® Packing List Tape — No. 8240

A unique tape which is used to attach and protect packing lists, shipping papers and other documents to a wide range of shipping containers. Quick, inexpensive, easy! Use with 3M™ M-727 Labelgard™ Tape dispenser (PN06944). Pouch size is 5" x 6".



Part Number	Pouches Per Roll	Rolls Per Case
021200-06947	500	8

## 3M™ ScotchPad™ 8240-P Packing List Tape

A unique tape which is available in convenient pad form. It offers a convenient system for attaching packing lists, shipping papers and other documents to a wide array of shipping containers. There is no dispenser necessary. The sheet size is 5" x 6", 25 sheets per pad.



Part Number	Sheets Per Pad	Pads Per Carton	Cartons Per Case
051131-06954	25	40	5

## Scotch® Packing List Tape — No. 825

Scotch® No. 825 Packing List Tape has a tough, scuff-resistant backing and aggressive packaging adhesive to securely attach packing lists and other mailing documents to most shipping container surfaces. It has a bright orange "Document Enclosed" border that makes packing lists easy to locate and remove without tearing documents. Pouch size is 5" x 6".



Part Number	Pouches Per Roll	Rolls Per Case
021200-17063	250	16

# Box Label Coating

## 3M™ Box Re-Nu Coating

A tan coating that dries quickly and permanently covers unwanted printing, stencils, labels, etc. on shipping containers. Resistance to moisture and scuffing makes this the ideal product for any shipping room. Contains no methylene chloride.



Part Number	Container Size	Cans Per Case
021200- <b>85851</b>	16 oz.	12

# Adhesive Transfer Tapes

## Scotch® ATG Adhesive Transfer Tape

Use this tape to hold, attach, bond, laminate, tab, join, fasten, mount, splice or seal nearly any surface — paper, foils, films, fabrics, glass, foams, plastics, metal, painted surfaces and wood. Tape is thin and tacky on both sides; one side adheres to applied surface, the other side is immediately ready to join a second surface. Provides instant tack and strong constant bond.



Part Number	Product Number	Thickness	Size	Rolls Per Case
021200- <b>04850</b>	950	5 Mil	1" x 60 yds.	36
051131- <b>06491</b>	924	2 Mil	1/2" x 36 yds.	72
051131- <b>06492</b>	924	2 Mil	3/4" x 36 yds.	48
051131- <b>06493</b>	969	5 Mil	1/2" x 18 yds.	72
051131- <b>06494</b>	969	5 Mil	3/4" x 18 yds.	48

## Scotch® ATG Dispenser

This dispenser is designed for use with our Scotch® ATG Tapes for easy dispensing. **NOTE: PRODUCT IS NOT INCLUDED WITH THE DISPENSER.**



Part Number	Each Per Case
021200- <b>06927</b>	6

## Scotch® Adhesive Transfer Tape — No. 465

Acrylic adhesive on a silicone-coated paper liner. Adhesive transfers from the liner easily to most smooth surfaces. Initial adhesion is very high. Used for miscellaneous holding, laminating, mounting and bonding applications.

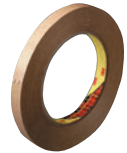

Part Number	Size	Rolls Per Case
021200- <b>03337</b>	1" x 60 yds.	36

## Scotch® Double-Coated Paper Tape — No. 400

A paper tissue coated with a high-shear adhesive on both sides. It has a treated crepe paper liner. Bonds well to almost any surface. Used where two adhesive surfaces are required or for splicing.



Part Number	Size	Rolls Per Case
021200- <b>03047</b>	1" x 36 yds.	36

# Pipe Thread Sealant Tape

## Scotch® Pipe Thread Sealant Tape — No. 48

This tape rolls on dry and molds into pipe threads to form a leak-proof seal. Unaffected by oils, transmission fluids or freon and never dries out. Permanently lubricated joints never stick.



Part Number	Size	Rolls Per Case
054007- <b>06192</b>	1/4" x 260"	12
054007- <b>06195</b>	1/2" x 260"	12
054007- <b>06196</b>	1/2" x 520"	12

# Foam and Paper Tapes

## Scotch® Double-Coated Paper Tape — No. 410

A paper tissue coated with a high-shear adhesive on both sides. It has a treated, easy-release paper liner. The tape's mirror-smooth, adhesive coat gives an exceedingly high level of adhesion to most clean, smooth surfaces. Used for splicing and where two adhesive surfaces are required.

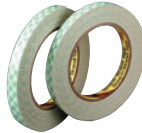

Part Number	Size	Rolls Per Case
021200- <b>23824</b>	1" x 36 yds.	36

## Scotch® Double-Coated 1/4" Urethane Foam Tape — No. 4004

A high density, urethane foam, with a long-aging acrylic adhesive on both sides. Treated green plaid paper liner. For a multitude of mounting and holding jobs. Applies to most clean, dry, unified surfaces, rough surfaces, too. Functions for extended periods at 225°F under conditions of proper loading. Provides thermal insulation; reduces vibration transmission.

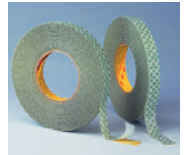

Part Number	Size	Rolls Per Case
021200- <b>03394</b>	1" x 18 yds.	9

# Foam and Paper Tapes

## 3M™ Scotch-Mount™ Double-Coated Urethane Foam Tapes

These urethane foam tapes are soft, conformable and offer excellent shear adhesion which makes them ideal for a wide range of general purpose mounting and joining applications. The acrylic adhesive forms long-aging bonds to many surfaces. Application ideas include mounting of mirrors, interior signs and wire/cable clips. The individually boxed short rolls are ideal for maintenance, repair and operation needs.



Part Number	Product Number	Size	Thickness	Rolls Per Case
<b>Bulk</b>				
051131- <b>06439</b>	4008	1" x 4 yds	1/8"	5
021200- <b>06452</b>	4008	1" x 36 yds.	1/8"	9
021200- <b>06455</b>	4016	1" x 36 yds.	1/16"	9
051131- <b>06440</b>	4026	1" x 6 yds	1/16"	5
021200- <b>06458</b>	4032	1" x 36 yds.	1/32"	9

## Scotch® Double-Coated Urethane Foam Tapes

A black, conformable, urethane foam with a long-aging, high-shear adhesive on both sides. These tapes offer high internal strength with a wide temperature range (-40°F to 225°F). For general purpose mounting and joining or applications where cold temperature performance is required. Applies to most clean, dry unified surfaces; rough surfaces, too.



Part Number	Product Number	Size	Rolls Per Case
021200- <b>14557</b>	4052	1" x 1/32" x 72 yds.	9
021200- <b>14558</b>	4056	1" x 1/16" x 36 yds.	9

## Scotch® Single-Coated Polyester Urethane Foam Tapes

An open cell low density charcoal gray polyester urethane with a pressure-sensitive acrylic adhesive on one side. This adhesive has excellent long-term aging, and ultimate high bond strength to a variety of surfaces as well as high temperature performance. Applications include gasketing and sealing for dust and light and damping and cushioning for sound and vibration.



Part Number	Product Number	Size	Rolls Per Case
051131- <b>06443</b>	4314	1" x 1/4" x 18 yds.	9
051131- <b>06446</b>	4317	1" x 3/8" x 9 yds.	9

## Scotch® Double-Coated 1/8" Vinyl Foam Tape — No. 4408

A black vinyl foam with long-aging adhesive on both sides. Treated green plaid paper liner. For a multitude of mounting and holding jobs while providing one-piece removal in most instances. Applies to most clean, dry, unified surfaces; rough surfaces, too. Functions for extended periods at 120°F. Provides thermal insulation. Reduces vibration transmission.



Part Number	Size	Rolls Per Case
021200- <b>03291</b>	1" x 36 yds.	9

## Scotch® Single-Coated Vinyl Foam Tape

A black vinyl foam with a long-aging adhesive on one side. Used for a variety of sealing, gasketing and vibration damping applications. For clean, dry, unified and rough surfaces too. Excellent for use in hatch cover weatherstripping.



Part Number	Product Number	Size	Thickness	Rolls Per Case
021200- <b>03314</b>	4508	1" x 36 yds.	1/8"	9
021200- <b>03318</b>	4504	1/2" x 18 yds.	1/4"	18
021200- <b>03319</b>	4504	3/4" x 18 yds.	1/4"	12
021200- <b>03320</b>	4504	1" x 18 yds.	1/4"	9

## Scotch® Double-Coated Acrylic Foam Tapes — No. 4945

45 mil white acrylic foam with an acrylic adhesive on both sides. This product features excellent resistance to plasticizer migration in flexible vinyls. It has a treated paper liner.

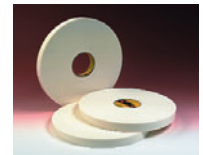

Part Number	Product Number	Size	Rolls Per Case
021200- <b>16955</b>	4945	1" x 36 yds.	9

## Scotch® Double-Coated Acrylic Foam Tapes — No. 4930, 4950

White closed cell acrylic foams with high-strength, long-aging acrylic adhesive on both sides. They have excellent immediate tack and feature the highest peel strengths available in a pressure-sensitive system. Available in 25 mil and 45 mil with treated paper liner. Primary applications are industrial assembly as an alternative to mechanical fasteners and liquid adhesives. The totally unique acrylic foam adds a new dimension to conformability without increasing the thickness.



Part Number	Product Number	Size	Rolls Per Case
021200- <b>18088</b>	4930	1" x 72 yds. 25 Mil	9
021200- <b>18092</b>	4950	1" x 36 yds. 45 Mil	9

# Tape Dispensers

## Scotch® Hand Dispensers

Provides a quick, easy and inexpensive method for sealing cartons with 2" wide rolls of box sealing tape. Lightweight, quick loading, and features metal cutting edge for long life. **NOTE: PRODUCT IS NOT INCLUDED WITH THE DISPENSER.**

Part Number	For Use With Roll Size	Dispensers Per Case
021200-06908	2" width	6

## 3M™ H-10 Filament Tape Dispenser

Accommodates all listed widths of filament tapes shown. **NOTE: PRODUCT IS NOT INCLUDED WITH THE DISPENSER.**



Part Number	Dispensers Per Case
021200-06910	6

## 3M™ M-707 Labelgard™ Dispenser

3M™ Labelgard™ Dispenser for address label applications. Applies and protects labels in one operation. Accommodates tape up to 4" wide. **NOTE: PRODUCT IS NOT INCLUDED WITH THE DISPENSER.**

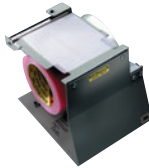

Part Number	Dispensers Per Case
021200-06923	6

## 3M™ H-122 Box Sealing Dispenser

A lightweight and durable hand dispenser for box sealing tapes. Accommodates tape up to 2" wide. **NOTE: PRODUCT IS NOT INCLUDED WITH THE DISPENSER.**



Part Number	Dispensers Per Case
021200-06925	6

## Scotch® ATG Dispenser

This dispenser is designed for use with our Scotch® ATG Tapes for easy dispensing. **NOTE: PRODUCT IS NOT INCLUDED WITH THE DISPENSER.**



Part Number	Dispensers Per Case
021200-06927	6

## 3M™ M-727 Labelgard™ Tape Dispenser

Designed for 3M™ Labelgard™ Tape. Accepts widths up to 5". Unique streamline construction allows for wall or bench mounting. **NOTE: PRODUCT IS NOT INCLUDED WITH THE DISPENSER.**

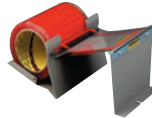

Part Number	Dispensers Per Case
021200-06944	6

## 3M™ H-12 Filament Tape Dispenser

Features a hand brake in the core that allows operator to adjust tension for tighter box reinforcement and bundling applications. Made from high-impact, durable plastic. Handles filament tapes up to 1" wide. **NOTE: PRODUCT IS NOT INCLUDED WITH THE DISPENSER.**



Part Number	Dispensers Per Case
021200-06953	6

## 3M™ H-171 Box Sealing Dispenser

Provides a quick and easy method for dispensing box sealing tape directly from the roll. Accommodates tape widths up to 2". **NOTE: PRODUCT IS NOT INCLUDED WITH THE DISPENSER.**



Part Number	Dispensers Per Case
021200-06955	6

## Highland™ HB-900 Table Top Dispenser

Ideal for mailing, shipping and wrapping stations. Weighted for convenient one-hand dispensing. Tape capacity to 1" wide on a 3" core. Refillable. **NOTE: PRODUCT IS NOT INCLUDED WITH THE DISPENSER.**

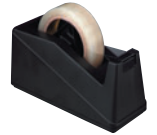

Part Number	Dispensers Per Case
051131-06993	12

## Highland™ HB-903 Pistol Grip Sealing Tape Dispenser

Easy-to-use, one-handed box sealing tape dispenser has an adjustable braking mechanism which applies tension to the tape. Holds tape up to 2" wide on a 3" core. Refillable. **NOTE: PRODUCT IS NOT INCLUDED WITH THE DISPENSER.**



Part Number	Dispensers Per Case
051131-06997	24

# Retail Packaged Tape Products/Displays

## Scotch® Colored Plastic Tape

Super thin, stretchy, waterproof vinyl plastic tape in two sizes. Each roll is cellophane wrapped. Mends, decorates, identifies. Great for color-coding and identifying rigging lines on sailboats. Available in red, green, brown, white, yellow, blue, black and clear.

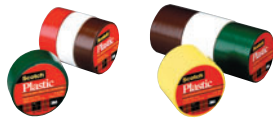

Part Number	Color	Rolls Per Pack	Rolls Per Case
<b>Catalog No. 190 — 3/4" x 125"</b>			
021200-00006	Clear	6	72
021200-00007	Red	6	72
021200-00008	Blue	6	72
021200-00009	White	6	72
021200-00010	Brown	6	72
021200-00011	Yellow	6	72
021200-00012	Green	6	72
021200-00013	Black	6	72

## Scotch® Colored Plastic Tape (continued)

Part Number	Color	Rolls Per Pack	Rolls Per Case
<b>Catalog No. 191 — 1-1/2" x 125"</b>			
021200-00014	Clear	6	72
021200-00015	Red	6	72
021200-00016	Blue	6	72
021200-00017	White	6	72
021200-00018	Brown	6	72
021200-00019	Yellow	6	72
021200-00020	Green	6	72
021200-00021	Black	6	72

## Tape Racks

Six tape racks with headers point of sale display for marine application.

**NOTE: PRODUCTS DO NOT COME WITH THE DISPLAY.**

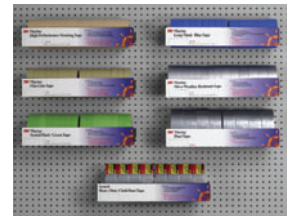

Part Number	Description	Racks Per Case
NEW 051131-03005	Rack	6

# Masking Paper

## 3M™ ScotchBlok™ Masking Paper

3M™ ScotchBlok™ Masking Paper is a tightly-bonded, specially-coated masking paper specifically manufactured for the marine aftermarket. This superior masking paper offers the ultimate penetration resistance from all solvents used in today's gelcoat and paint systems. 3M™ ScotchBlok™ Masking Paper's bonded fiber formation reduces contamination of freshly painted and varnished surfaces and provides excellent conformability and holds up well under wet sanding conditions. Distinctive gold color for easy identification.



Part Number	Size	Rolls Per Case
051131-06706	6" x 750 ft.	6
051131-06712	12" x 750 ft.	3
051131-06715	15" x 750 ft.	2
051131-06718	18" x 750 ft.	2
051131-06736	36" x 750 ft.	1
051131-06726	6" x 180 ft.	12
051131-06729	9" x 180 ft.	12
051131-06732	12" x 180 ft.	12
051131-06738	18" x 180 ft.	12

## Scotch® Masking Paper

A steel grey-colored specially processed high-density paper with excellent penetration resistance designed for exacting requirements of paint masking.



Part Number	Size	Rolls Per Case
021200-06503	3" x 1000 ft.	6
021200-06506	6" x 1000 ft.	6
021200-06509	9" x 1000 ft.	4
021200-06512	12" x 1000 ft.	3
021200-06515	15" x 1000 ft.	2
021200-06518	18" x 1000 ft.	3
021200-06524	24" x 1000 ft.	2
021200-06530	30" x 1000 ft.	1
021200-06536	36" x 1000 ft.	1

# Masking Paper

## 3M™ White Masking Paper

3M™ White Masking Paper is specifically manufactured for the marine after-market. It offers good protection against bleed-thru from gelcoat and urethane, enamel and lacquer paint systems. The tightly bonded paper protects against fiber contamination and conforms easily to irregular surfaces.



Part Number	Size	Rolls Per Case
051131-06507	6" x 180 ft.	12
051131-06508	12" x 180 ft.	12
051131-06510	18" x 180 ft.	12
051131-06537	6" x 750 ft.	6
051131-06538	12" x 750 ft.	3
051131-06539	18" x 750 ft.	2
051131-06540	36" x 750 ft.	1

## Scotch® Bold Brick Masking Paper

This high-density masking paper offers excellent penetration resistance from solvents used in today's paints. Protects against dust contamination from paper fibers. Provides good conformability while minimizing premature puncturing and tearing.



Part Number	Size	Rolls Per Case
051131-06603	3" x 750 ft.	6
021200-06606	6" x 750 ft.	6
051131-06609	9" x 750 ft.	4
021200-06612	12" x 750 ft.	3
021200-06615	15" x 750 ft.	2
021200-06618	18" x 750 ft.	2
051131-06624	24" x 750 ft.	1
021200-06636	36" x 750 ft.	1

## 3M™ Red Masking Paper

For utility and non-critical masking applications. Has acceptable conformity.



Part Number	Size	Rolls Per Case
051131-06708	6" x 750 ft.	6
051131-06710	12" x 750 ft.	3
051131-06711	18" x 750 ft.	2
051131-06713	36" x 750 ft.	1
051131-06714	6" x 180 ft.	12
051131-06716	12" x 180 ft.	12
051131-06717	18" x 180 ft.	12

## 3M™ Utility Grade Masking Paper (Green)

This masking paper is designed for non-critical masking applications or when paint is applied by brush or roller. This paper is not generally recommended for spray painting applications.



Part Number	Size	Rolls Per Case
051131-77401*	3" x 60 yds.	12
051131-77402**	6" x 60 yds.	12
051131-77403***	9" x 60 yds.	12
051131-77399†	12" x 60 yds.	12
051131-77400††	15" x 60 yds.	12
051115-06904	18" x 60 yds.	12

\* Replaces PN 046544-52001

\*\* Replaces PN 046544-52003

\*\*\* Replaces PN 046544-52005

† Replaces PN 046544-52007

†† Replaces PN 046544-52009

## Tartan™ Green Masking Paper

A general purpose utility grade masking paper. This strong, heavyweight paper is good for priming and non-critical paint masking.

	Part Number	Size	Rolls Per Case
NEW	051131-06520	6" x 450'	6
NEW	051131-06521	12" x 450'	3
NEW	051131-06525	18" x 450'	2
NEW	051131-06527	36" x 450'	1



# Masking Films and Maskers

## 3M™ Hand-Masker™ Pre-Folded Masking Film Rolls

3M™ Hand-Masker™ Pre-Folded Masking Film Rolls are a high-density, non-porous film specially designed for paint masking and paint overspray protection. The 9" x 100' roll folds down to 72" width and 12" x 100' roll folds down to 99" width to offer paint overspray protection for larger surface areas on deck or hull.



Part Number	Description/Size	Rolls Per Case
051131-06848	MF-48 48" x 180'	12

Part Number	Description	Blades Per Case
051131-06802	12" Masking Film Cut-Off Blade	6

Part Number	Description/Size	Rolls Per Case
051131-06845	MF-24 24" x 180'	12
051131-77406	MF-72 72" x 90'	12
051131-77407	MF-99 99" x 90'	12

## 3M™ Paintable Plastic Sheeting

3M™ Paintable Plastic Sheeting is a uniquely formulated 1/2 mil micro etched film that provides excellent paint adherence. It reduces masking labor time by eliminating a paint masking step. This sheeting has a center seam for easy alignment and the fold pattern allows for easy application. The sixteen-foot width is for larger vehicles such as sport utilities and pickup trucks to cover all surfaces. Use with 3M™ Overspray Protective Sheeting Masker (PN06780).



Part Number	Size	Each Per Case
051131-06739	12' x 400'	1
051131-06740	16' x 400'	1

## 3M™ Ready-Mask™ Pre-Loaded Dispensers

A convenient, pre-taped plastic film which unfolds to cover and protect various surfaces while painting. Specially treated film clings to surfaces and is easy to clean up.

Part Number	Description	Dispensers Per Case
051115-07997	Dispenser pre-loaded with 24" x 30 yds. 3M™ Long-Mask™ Masking Tape – No. 2090 (PN06696)	12

## 3M™ Ready-Mask™ Pre-Taped Masking Film with 3M™ Long-Mask™ Masking Tape — No. 2090

A convenient, pre-taped plastic film which unfolds to cover and protect various surfaces while painting. Specially treated film clings to surfaces and is easy to clean up. Pre-taped with 3M™ Long-Mask™ Masking Tape #2090, which is sunlight stable, and gives the user 7-day clean removal.



Part Number	Roll Size	Rolls Per Case
051131-06696	24" x 30 yds.	12
051131-06697	35" x 25 yds.	12

## 3M™ Overspray Protective Sheeting

A high density, tear resistant, clear film that is treated on both sides for excellent paint overspray adhesion. Twelve-foot film folded to three feet for easy one-person application. Sixteen foot width accommodates larger surface areas for more effective overspray protection. Use with Masker PN06780.



Part Number	Size	Rolls Per Case
051131-06727	12' x 400' Clear (Folds down to 3')	1
051131-06728	16' x 400'	5

## 3M™ Overspray Protective Sheeting Masker

A portable masker designed to dispense 3M™ Overspray Protective Sheeting. It can be used horizontally, vertically or wall mounted. The spring-loaded end frame is designed for easy loading of Overspray Protective Sheeting. **NOTE: PROTECTIVE SHEETING IS NOT INCLUDED WITH THE MASKER.**

Part Number	Masks Per Case
051131-06780	1

## 3M™ Hand-Masker™ M3000 Kit

This kit consists of the 3M™ Hand-Masker™ M3000 Dispenser with multi-purpose hook, a 12" masking film cut-off blade and the 3M™ Hand-Masker™ Tack-Down Tape Dispenser. **NOTE: MASKING PAPER NOT INCLUDED WITH KIT.**



Part Number	Kits Per Case
051131-06788*	4

\* Replacement for PN06799

## 3M™ Hand-Masker™ M3000FTK Film Tape Kit

Kit includes M3000 dispenser with multi-purpose hook, 1 roll Scotch® Long-Mask™ Masking Tape #2090-1", 1 roll MF48 48" x 180' pre-folded film and 1 FB12 12" film blade.



Part Number	Kits Per Case
051131-79284	4

# Masking Films and Maskers

## 3M™ Hand-Masker™ Dispenser M3000

The 3M™ Hand-Masker™ M3000 Dispenser applies masking tape to masking film up to 144" or paper up to 18" in one continuous application. Compact, lightweight, saves time. For professional heavy duty use.



Part Number	Dispensers Per Case
NEW 051131-77385	4

## 3M™ Hand-Masker™ M2000 Dispenser

This dispenser applies masking tape to masking film (up to 72") or masking paper (up to 12"). A convenient wrist strap lets you free your hands and can be used to hang the dispenser on a hook. The M2000 dispenser is the choice for light-duty masking.



Part Number	Dispensers Per Case
051131-77384	4

## 3M™ Hand-Masker™ M2000FTK Film Tape Kit

Kit includes M2000 dispenser with multi-purpose hook, 1 roll Scotch® Long-Mask™ Masking Tape #2090-1", 1 roll MF24 24" x 180' pre-folded masking film and 1 FB6 6" film blade.



Part Number	Kits Per Case
051131-79283	4

## 3M™ Hand-Masker™ Dispenser Cut-Off Blades

These 3M™ Cut-Off Blades are designed for use in conjunction with the 3M™ Hand-Masker™ Dispenser Model M-3X III.



Part Number	Size	Blades Per Case
051131-06794	6"	6
051131-06795	9"	6
051131-06796	12"	6
051131-06797	15"	6
051131-06798	18"	6

## 3M™ Hand-Masker™ Tack-Down Tape Dispenser

This accessory attachment for the 3M™ Hand-Masker™ Dispenser accommodates an additional roll of masking tape for tacking down the loose end of masking paper during masking applications. **NOTE: MASKING PAPER NOT INCLUDED WITH DISPENSER ATTACHMENT.**



Part Number	Dispensers Per Case
051131-06787*	6

\* Replacement for PN06789

## Scotch® DT30 Dual-Tac™ Tape

Apply to masking tape with the DT1 dispenser to hold poly and untaped edges of masking film.



Part Number	Description	Rolls Per Pack	Packs Per Case
051131-76741*	3/4" x 60 yds. Orange Dual-Tac™ Tape	6	4

\* Replacement for 03676 and 06922

## 3M™ Hand-Masker™ Film Blades

A durable, sharp, stainless-steel blade with plastic blade guard.



Part Number	Description	Blades Per Case
051131-06804	6" Masking Film Cut-Off Blade	6

## 3M™ Hand-Masker™ Pre-taped Drop Cloth

When it comes to protecting surfaces from paint drips, splatter and overspray, 3M™ Hand-Masker™ Pre-taped Drop Cloths have it covered. No matter how large or small the area to cover, there's a pre-taped drop cloth ideal for the job. Benefits: pre-taped to make masking an easy, one-step job; Each unfolds to protect and cover both large and small areas; Two kinds of tape for different masking conditions; Scotch® Safe-Release™ Painters' Masking Tape #2090 is sunlight and UV-resistant for clean removal for up to 14 days – even on glass exposed to direct sunlight; Made of film for easier clean-up than conventional drop cloths.

Part Number	Description	Each Per Case
051131-80058	90' with dispenser	6
051131-80055	90'	8
051131-80053	72' with dispenser	6
051131-80052	72'	8
051131-80056	50' with dispenser	6
051131-80054	50'	8

# Masking Machines

## Scotch® Cart Masker

The Scotch® Cart Masker dispenses one roll of masking paper up to 18" on each of the two levels. With the purchase of 3M™ Conversion Kit (PN06782) it becomes a three-roll capacity masker. This masker has large, deep storage trays on the top and bottom. The narrow width, large handle, and 8" wheels make moving it very easy. In addition, this masker has a built in storage rack for spray guns, and two hooks for Scotch® Paint Masking Tape – No. 233, or Scotch® Plastic Tape – No. 471, Blue. It is very easy to assemble. Note: Masking Paper not included with masker.



Part Number	Masks Per Case
051131-06781	1

## Scotch® Tray Masker

The Scotch® Tray Masker dispenses single rolls of masking paper. Built into the top is a handy large storage tray. This masker can be wall mounted. It is very easy to assemble. With the purchase of 3M™ Conversion Kit (PN06782), it becomes a two-roll masker. Available in either an 18" or 36". **NOTE: MASKING PAPER NOT INCLUDED WITH MASKER.**



Part Number	Maximum Width of Masking Paper	Masks Per Case
051131-06783	36"	1
051131-06784	18"	1

## Scotch® Utility Masker

This Scotch® Utility Masker provides the means for dispensing single aprons up to 12" wide and the convenience of portability. The masker is easily operated and incorporates a large handy storage tray. **NOTE: MASKING PAPER NOT INCLUDED WITH MASKER.**



Part Number	Masks Per Case
021200-06810	1

## Scotch® Handy Masker

Designed for fast, convenient masking. Strong, portable, compact and lightweight. Dispenses 3", 6", 9" or 12" masking paper. **NOTE: MASKING PAPER NOT INCLUDED WITH MASKER.**



Part Number	Masks Per Case
021200-06814	1

## Scotch® Slimline Apron Taper

The Scotch® Slimline Apron Taper Dispenses three rolls of masking paper up to widths of 18" and can be easily moved from job to job with one-hand mobility. It maintains proper tape and paper alignment and doesn't require adjusting. **NOTE: MASKING PAPER NOT INCLUDED WITH TAPER.**



Part Number	Tapers Per Case
021200-06864	1

## Scotch® Apron Taper — 18"

Masking jobs are faster and easier with this unit that dispenses single paper aprons through 18" wide or adapts for most combinations up through 18" with conversion kit. **NOTE: MASKING PAPER NOT INCLUDED WITH TAPER.**



Part Number	Tapers Per Case
021200-06865	1

## Scotch® Apron Taper — 36"

Dispenses single aprons through 36" width or adapts for any combination of two paper widths up through 36". **NOTE: MASKING PAPER NOT INCLUDED WITH TAPER.**



Part Number	Tapers Per Case
021200-06866	1

## Scotch® Multi Mobile Masker

The complete masker that reduces labor costs. It's fast and convenient. Two-roll capacity with top and bottom dispensing system. Dispenses single aprons through 18" wide. Laminates tape to paper as paper is dispensed. It comes easy to assemble — insert two bolts to complete frame and four bolts to mount lower cutting blade. With purchase of Scotch® Conversion Kit (PN06782) it becomes a three-roll capacity dispenser. **NOTE: MASKING PAPER NOT INCLUDED WITH MASKER.**



Part Number	Masks Per Case
021200-06869	1

## Scotch® Mobile Frame

Designed to have the Scotch® Apron Taper (PN06866) added to the top, this frame is for those wishing to build a mobile 36" dispenser. Preassembled except for insertion of two bolts to make frame operative.



Part Number	Frames Per Case
021200-06871	1

## Scotch® Conversion Kit

The kit is designed to add extra capacity to Scotch® Maskers. The kit includes 1 paper roll double hub bracket assembly, two paper roll bracket assemblies, one spring brake, one tape drum for converting Scotch® Maskers (PNs 06781, 06783, 06784), and one tape drum for converting Scotch® Apron Tapers (PNs 06865 and 06866) and Scotch® Multi Mobile Masker (PN06869).

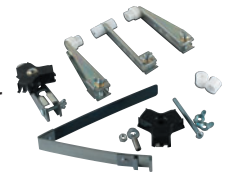

Part Number	Kits Per Case
051131-06782	1

# Welding Drape

## 3M™ Welding and Spark Deflection Paper

A flame retardant deflection paper formulated to protect vertical surfaces, glass and paint from welding splatter and grinding sparks. Comes in an easy-to-use roll form with repositionable adhesive on one side.



Part Number	Roll Size	Rolls Per Case
051131-05916	24" x 150'	2

## 3M™ Welding and Spark Deflection Dispenser

This dispenser is designed for use with single rolls of 24" 3M™ Welding and Spark Deflection Paper (PN05916). It is very easy to assemble and can be wall or table mounted.



Part Number	Dispensers Per Case
051131-05912	1

## 3M™ Lightweight Welding Drape

The 3M™ Lightweight Welding Drape resists penetration by MIG weld spatter or grinding sparks. It is self-extinguishing to protect from welding spark flame-up. Lightweight, drapable material allows one person to handle and position the drape correctly.



Part Number	Size	Drapes Per Case
051131-05915	53" x 72"	4

## 3M™ High Performance Welding Drape

3M™ High Performance Welding Drape has a unique construction of 100% carbon fiber. This sets this product apart from others used to protect surfaces from spark and weld splatter. Exceptional wear and tear resistance makes this drape one that won't need to be replaced as often. At 57" x 80", it is the optimal size for local protection. Packed one blanket per case; each drape is packed in an upgraded zippered vinyl bag for storage.



Part Number	Size	Drapes Per Case
NEW 051131-05919	57" x 80"	1

# 3M™ Marine Preferred Adhesives and Sealants

## Adhesive/Sealants

Product	Part Number
3M™ Marine Adhesive/Sealant 5200	05206 White 1 oz. Tube 05203 White 3 oz. Tube 05205 Black 3 oz. Tube 06500 White 1/10th Gallon Cartridge 06501 Tan 1/10th Gallon Cartridge 06502 Mahogany 1/10th Gallon Cartridge 06504 Black 1/10th Gallon Cartridge 21463 White 5 Gallon Pail 21456 Mahogany 5 Gallon Pail
3M™ Marine Adhesive/Sealant Fast Cure 5200	05220 White 3 oz. Tube 06520 White 1/10th Gallon Cartridge
3M™ Marine Adhesive/Sealant Fast Cure 4200	05260 White 3 oz. Tube 05261 Black 3 oz. Tube 06560 White 1/10th Gallon Cartridge 06564 Black 1/10th Gallon Cartridge
3M™ Marine Adhesive/Sealant Fast Cure 4000UV	05280 White 3 oz. Tube 06580 White 1/10th Gallon Cartridge 06586 White 400 ml Flex Pack
3M™ OEM Adhesive/Sealant	06566 White 400 ml Flex Pack 06568 Black 400 ml Flex Pack

## Sealants

Product	Part Number
3M™ Marine Sealant 101	06510 White 1/10th Gallon Cartridge
3M™ Marine Grade Silicone Sealant	08017 White 3 oz. Tube 08019 Clear 3 oz. Tube 08027 White 1/10th Gallon Cartridge 08029 Clear 1/10th Gallon Cartridge

## Adhesives

Product	Part Number
3M™ Marine Automix™ Fast Cure Epoxy Adhesive (Clear)	08107 2 oz. 3M™ Automix™ Duo-Pak
3M™ Quick Fix Adhesive (Cyanoacrylate)	08155 1 oz. Bottle
3M™ Fastbond™ 30NF Contact Adhesive (Neutral)	21180 Quart 21181 Gallon 21182 5 Gallon Pail 21183 52 Gallon Drum
3M™ 10 Fastbond™ Contact Adhesive (Neutral)	20272 Quart 20274 Gallon
3M™ General Trim Adhesive (Clear - Low VOC)	08088 24 oz. Aerosol 08089 8 oz. Aerosol
3M™ Super Trim Adhesive	08090 24 oz. Aerosol 08091 8 oz. Aerosol
3M™ Low Mist Super 77 Spray Adhesive	21210 24 oz. Aerosol

# Adhesives/Sealants

## 3M™ Marine Adhesive/Sealant 5200

This high-performance polyurethane adhesive/sealant becomes tack free in 48 hours, completely cures in 5-7 days with no shrinkage. The seal is extremely strong, retains its strength above or below the water line. Stays flexible too — allows for structural movement. Stress caused by shock, vibration, swelling or shrinking is effectively absorbed. Has excellent resistance to weathering and salt water.

Check the bonding and sealing jobs this product can handle for you: fiberglass deck to fiberglass hull, wood to fiberglass, porthole frames and deck fittings, under mouldings, hull seams above and below water line. Stern joints. Deck housing, etc. Easy to apply with manual caulking gun. Remains workable with trowel or spatula up to four hours after application. Won't sag or flow in vertical or horizontal seams. Available in tubes, cartridges and pails.



Part Number	Color	Container Size	Tubes Per Case
<b>Tubes — Carded</b>			

051135-05203	White	3 oz.	6
051135-05205	Black	3 oz.	6
051135-05206	White	1 oz.	12

Part Number	Color	Container Size	Cartridges Per Case
<b>Cartridges</b>			

051135-06500	White	1/10 Gallon	12
051135-06501	Tan	1/10 Gallon	12
051135-06502	Mahogany	1/10 Gallon	12
051135-06504	Black	1/10 Gallon	12

Part Number	Color	Container Size	Pails Per Case
<b>Pails</b>			

021200-21463	White	5 Gallon	1
021200-21456	Mahogany	5 Gallon	1

## 3M™ OEM Adhesive/Sealant

A one-part general purpose polyurethane that chemically reacts with moisture to deliver flexible bonds with good adhesion to wood, fiberglass, gelcoat, certain plastics and metals. Sandable. Forms watertight, weather-resistant seals on joints and boat hardware above or below the waterline. This product is approximately half the strength of 3M™ Marine Adhesive/Sealant 5200, which allows for disassembly of parts.

**Note:** When very high strength or unremovable bonds are required, use 3M™ Marine Adhesive/Sealant 5200 or 3M™ Marine Adhesive/Sealant Fast Cure 5200. Not recommended for sealing wood decks because it may be permanently softened by certain teak cleaners or sealers. On plastics, test 3M™ Marine Adhesive/Sealant Fast Cure 4200 to determine suitability.



Part Number	UPC Number	Color	Container Size	Packs Per Case
06566	051131-16566	White	400 ml	25
06568	051131-16568	Black	400 ml	25

## 3M™ Marine Adhesive/Sealant Fast Cure 5200

A faster curing version of 3M™ Marine Adhesive/Sealant 5200. The high-performance polyurethane becomes tack free in one hour and fully cures in approximately 24 hours. The seal is extremely strong, retains its strength above or below the water line. Stays flexible — allows for structural movement. Stress caused by shock, vibration, swelling or shrinking is effectively absorbed. Has excellent resistance to weathering and salt water.



Part Number	Color	Container Size	Tubes Per Case
<b>Tubes — Carded</b>			

051135-05220	White	3 oz.	6
--------------	-------	-------	---

Part Number	Color	Container Size	Cartridges Per Case
<b>Cartridges</b>			

051135-06520	White	1/10 Gallon	12
--------------	-------	-------------	----

## 3M™ Marine Adhesive/Sealant 5200 Floor Display

This display is for retailers and yards with 5200 customers. Floor display consists of 108 cartridges of 3M™ Marine Adhesive/Sealant 5200 (PN06500). The display ships complete; take “shroud” off and it is ready to sell. Top row already cut for display. Sell through each tray, remove or refill.



Part Number	Displays Per Case
051135-06499	1

## 3M™ Marine Adhesive/Sealant Fast Cure 4200

A one-part general purpose polyurethane that chemically reacts with moisture to deliver flexible bonds with good adhesion to wood, fiberglass, gelcoat, certain plastics and metals. Sandable. Forms watertight, weather-resistant seals on joints and boat hardware above or below the waterline. This product is approximately half the strength of 3M™ Marine Adhesive/Sealant 5200, which allows for disassembly of parts.

**Note:** When very high strength or unremovable bonds are required, use 3M™ Marine Adhesive/Sealant 5200 or 3M™ Marine Adhesive/Sealant Fast Cure 5200. Not recommended for sealing wood decks because it may be permanently softened by certain teak cleaners or sealers. On plastics, test 3M™ Marine Adhesive/Sealant Fast Cure 4200 to determine suitability.



Part Number	Color	Container Size	Tubes Per Case
<b>Tubes — Carded</b>			

051135-05260	White	3 oz.	6
--------------	-------	-------	---

NEW 051135-05261	Black	3 oz.	6
------------------	-------	-------	---

Part Number	Color	Container Size	Cartridges Per Case
<b>Cartridges</b>			

051135-06560	White	1/10 Gallon	12
--------------	-------	-------------	----

051135-06564	Black	1/10 Gallon	12
--------------	-------	-------------	----

# Adhesives/Sealants

## 3M™ Adhesion Promoter

A liquid primer packaged in convenient, single-use applicator packets. Can be applied on common low-surface energy plastics used for dash and interior trim applications. One packet covers approximately 150 square inches of substrate at the recommended coating thickness.



	Part Number	Size	Each Per Box	Boxes Per Case
NEW	051131-06396	2.5 cc	25	4

## 3M™ Citrus Base Adhesive Remover

3M™ Adhesive Remover Citrus Base is a multi-purpose aerosol or bulk cleaner effective in removing many partially dried and some types of fully cured adhesives without leaving a residue.

	Part Number	Container Size	Containers Per Case
NEW	021200-49048	24 oz. Aerosol	6
NEW	021200-49142	1 Gallon	4
NEW	021200-49143	5 Gallon Pail	1
NEW	021200-49144	55 Gallon Drum	1

## 3M™ Marine Sealant 101

This high-quality polysulfide bedding and deck seam sealant chemically cures to form a firm, rubbery watertight seal. Seals between mechanically fastened joints on wood, fiberglass, metal, and most plastics; above and below the waterline. Non-sagging, non-shrinking formula becomes tack free in 5 hours and remains permanently flexible. Excellent resistance to chemicals, weathering, salt water, and stresses caused by joint movement.



	Part Number	Color	Container Size	Cartridges Per Case	Containers Per Case
	<b>Cartridges</b>				
	051135-06510	White	1/10 Gallon	12	
NEW	051135-06580		1/10 Gallon Cartridge		12
NEW	051135-06586		400 ml Flex Pack		12
NEW	051135-05280		3 oz.		6

## 3M™ Marine Grade Silicone Sealant

A mildew resistant non-sagging, moisture-curing silicone rubber sealant. Remains flexible with excellent resistance to the marine environment. Adheres to bare and painted metal, fiberglass, glass, non-oily woods and many plastics and abraded rubbers. Ideal for head and galley sealing applications. Also excellent gasket adhesive and formed-in-place gasket material.



	Part Number	Color	Container Size	Containers Per Case
	<b>Tubes — Carded</b>			
	051135-08017	White	3 oz.	6
	051135-08019	Clear	3 oz.	6
	Part Number	Color	Container Size	Cartridges Per Case
	<b>Cartridges</b>			
	051135-08027	White	1/10 Gallon	12
	051135-08029	Clear	1/10 Gallon	12

## 3M™ Marine Adhesive/Sealant Fast Cure 4000UV

This high quality cosmetic sealant cures to form a firm, rubbery, water-tight seal. Superior UV resistance. Very low odor. Resistant to weathering, saltwater and stresses caused by joint movement. Remains flexible. Seals between mechanically fastened joints on wood, fiberglass, metal and most plastics above and below the waterline. Applications include sealing deck to hull joints, thru-hull fittings, window and door frames, deck hardware, transducers, transoms, navigation lights, hatches and porthole frames.



	Part Number	Container Size	Containers Per Case
NEW	051135-06580	1/10 Gallon Cartridge	12
NEW	051135-06586	400 ml Flex Pack	12
NEW	051135-05280	3 oz.	6

## Coverage Calculator Table

Given the seam dimensions, chart provides lineal feet per cartridge (assumes no waste).

		Seam Width (inches)				
		1/8	3/16	1/4	5/16	3/8
Seam Depth (inches)	1/8	96.3	64.2	48.1	38.5	32.1
	3/16	64.2	42.8	32.1	25.7	21.4
	1/4	48.1	32.1	24.1	19.3	16.0
	5/16	38.5	25.7	19.3	15.4	12.8
	3/8	32.1	21.4	16.0	12.8	10.7
	7/16	27.5	18.3	13.8	11.0	9.2

# Sealants

## 3M™ Cartridge Applicator Gun

1/10 gallon cartridge gun for use with adhesive, sealants and glazing compound cartridges.



Part Number	Each Per Case
051135-08992	12

## 3M™ Professional Caulking Gun

The 3M™ Professional Caulking Gun is a high-performance gun, designed for the professional, to be used for dispensing 1/10 gallon sized cartridges.



Part Number	Each Per Case
051135-08993	1

## 3M™ Flexible Package Applicator Gun

A fully enclosed, all metal, rod driven, friction feed applicator gun for use with all 310 ml or smaller foil flexible packages.



Part Number	Each Per Case
051135-08398	1

## 3M Sealers, Coatings and Adhesives Organizer

This organizer has one door which opens either on the right or on the left, is lockable and can be hung on a wall or placed on a shelf. It measures 30-1/8" high, 14-1/8" wide and 12-1/8" deep and is made of sturdy 24 gauge American steel. The weight is 26 pounds. Not a 3M product. To order, call Shopware at 1-800-877-9344. **NOTE: PRODUCT IS NOT INCLUDED WITH THE ORGANIZER.**



Part Number	Description	Each Per Case
051131-02508 (Not stocked as a 3M item.)	Right Side (door opens on left)	1
051131-02509 (Not stocked as a 3M item.)	Left Side (door opens on right)	1

## 3M™ Flex Pack Heavy Duty Applicator Gun

A fully enclosed, all metal, rod driven, friction feed applicator gun for use with 3M™ Windshield Urethanes.



Part Number	Each Per Case
051135-08991	1



# Adhesives

## 3M™ Super Weatherstrip Adhesive

For adhering all types of weatherstrip to doors. Light colored, very fast drying, exceptional bonding strength. Used as a gasket adhesive on engines.



Part Number	Container Size	Tubes Per Case
051135-08001	5 oz. Tube	6

## 3M™ Weatherstrip Adhesive — Black

For bonding trim fabrics (except vinyl), deck mats and rugs, etc. Also good general cement. Has quick tack and will not bleed through fabric.



Part Number	Container Size	Tubes Per Case
051135-08011	5 oz. Tube	6

## 3M™ Fast Tack Adhesive

A light-colored, extremely fast-drying, non-stain adhesive with long tack for attaching vinyl and other kinds of trim fabric, upholstery, floor mats and carpeting.



Part Number	Container Size	Tubes Per Case
051135-08031	5 oz. Tube	6

## 3M™ Feathering Disc Adhesive Type II

3M™ Feathering Disc Adhesive Type II is specially formulated to allow multiple disc applications without adhesive buildup or paper delamination. Discs remove easily and cleanly.



Part Number	Container Size	Tubes Per Case
051135-08051	5 oz. Tube	6

## 3M™ 2084 Scotch-Seal™ Metal Sealant

An aluminum colored, general purpose, medium viscosity sealant with good adhesion to aluminum and glass. Ideally suited for beading glass in aluminum window channels.



Part Number	Container Size	Tubes Per Case
021200-20227	5 oz. Tube	36

## 3M™ Strip-Calk

For sealing openings where a soft, non-hardening material is needed. Good for use in seams and under deck hardware. 3M™ Strip-Calk is waterproof, will not shrink, can be painted and requires no application tools. Each box contains 60, 1 ft. lengths.



Part Number	Color	Containers Per Case
051135-08578	Black	12

## 3M™ Spray Disc Adhesive

A transparent, instant tack adhesive for bonding feathering discs. Can use many discs per adhesive application without adhesive buildup. Discs remove easily and cleanly.



Part Number	Container Size	Cans Per Case
051135-08054	8 oz. Aerosol	6

## 3M™ Spray Trim Adhesive

A transparent, extremely fast drying adhesive with long tack for attaching upholstery cloth, floor mats, carpeting, etc. to painted or bare metal, wood, KB board or other trim materials. May also be used to bond styrofoam.



Part Number	Container Size	Cans Per Case
051131-08074	24 oz. Aerosol	6

## 3M™ General Trim Adhesive — Clear, Low VOC

A fast-drying, high-strength, 50% VOC clear adhesive in an aerosol container. Designed for bonding most types of trim used in boat trim except unsupported vinyl. Excellent for fabrics, upholstery foam, carpets. Do not use on styrofoam.



Part Number	Container Size	Cans Per Case
051135-08088	24 oz. Aerosol	4
051135-08089	— No Longer Available —	

## 3M™ Super Trim Adhesive

3M™ Super Trim Adhesive is a fast-acting, high-strength, aerosol contact adhesive designed for two-surface application. This adhesive is resistant to heat and plasticizing oils and is excellent for attaching vinyl, insulation, foam, padding and rubber parts to metal and other surfaces. Bonds can be made within minutes of application or as long as one hour later.



Part Number	Container Size	Cans Per Case
051131-08090	24 oz. Aerosol	6
051135-08091	— No Longer Available —	

## 3M™ Structural Adhesive Kit

A two-part general purpose gray adhesive that may be used for miscellaneous fiberglass repair and bonding trim ornaments.



Part Number	Container Size	Kits Per Case
051135-08101	2-2 fl. oz./kit	6

# Adhesives

## 3M™ Automix™ Fast Cure Epoxy Adhesive — Clear

A super strong two-part epoxy for bonding metal, glass, plastic, wood and fiberglass. Adhesive is conveniently dispensed by the 3M™ Automix™ Applicator Gun (PN08191). If automatic mixing is desired as the adhesive is being dispensed, use a 3M™ Mixing Nozzle (PN08197).



Part Number	Duo-Paks Per Case
051135- <b>08107</b>	6

## 3M™ Heavy Duty 2 oz. Automix™ Applicator Gun

Designed for use with all 3M™ 2 oz. Automix™ products.



Part Number	Each Per Case
051135- <b>08191</b>	1

## 3M™ Mixing Nozzles — Clear

Use with 3M™ Automix™ Fast Cure Epoxy Adhesive if automatic mixing is desired as the adhesive is being dispensed. Packaged 6 nozzles per bag, 6 bags per case.



Part Number	Nozzles Per Bag	Bags Per Case
051135- <b>08197</b>	6	6

## 3M™ Quick Fix Adhesive (Cyanoacrylate)

3M™ Quick Fix Adhesive is a strong, rapid-bonding, convenient-to-use adhesive. It has excellent adhesion to most rubber, weatherstripping, vinyl, metals, glass, wood and plastics as well as excellent resistance to temperature extremes, shock and most marine chemicals and fluids.



Part Number	Container Size	Bottles Per Case
051135- <b>08155</b>	1 oz. Bottle	12

## 3M™ Ultrapro™ High Temp Silicone Gasket

Premium grade compound for form-in-place gasketing. Range from -20°F to 600°F. Oxygen sensor safe.



Part Number	Container Size	Color	Tubes Per Case
051135- <b>08672</b>	3 fl. oz. Tube	Black	6

## 3M™ Release Agent

A special solvent blend that quickly softens adhesive bonds between marine weatherstrip and metal.



Part Number	Container Size	Cans Per Case
051135- <b>08879</b>	– No Longer Available –	

## 3M™ General Purpose Adhesive Cleaner

A specially blended solvent that provides easy cleanup of most types of adhesives, and quickly removes waxes, greases, oil and tars. When properly used, it will not harm thoroughly dried paint, vinyl or fabrics.



Part Number	Container Size	Containers Per Case
051135- <b>08984*</b>	Quart Can	6
051135- <b>08986*</b>	5 Gallon Pail	1
051135- <b>08987</b>	20 oz. Aerosol Can	12

\* This product cannot be purchased for use in Southern California per the California South Coast Air Quality District Rule 1171.

## 3M™ Scotchgrip™ 1300L Rubber and Gasket Adhesive

A yellow, premium quality, versatile, heat resistant adhesive that develops strength rapidly. Has excellent adhesion to metal, wood, most plastics, and neoprene, reclaim, SBR, and butyl rubber.

Part Number	Container Size	Containers Per Case
021200- <b>19936</b>	5 Gallon Pail	1

## 3M™ 10 Fastbond™ Contact Adhesive — Neutral

A brushable, air-drying, neutral-colored contact adhesive used for bonding decorative laminates, aluminum, steel, wallboard, plywood, panels, wood and wood veneer, rubber, canvas and other porous and non-porous materials to each other or to themselves. Bonds immediately and permanently upon application eliminating the need for clamping or fixturing the materials being bonded. Offers exceptional high-bond strength and superior resistance to heat and sunlight.



Part Number	Container Size	Containers Per Case
021200- <b>20272</b>	Quart	12
021200- <b>20274</b>	Gallon	4

## 3M™ Fastbond™ 30NF Contact Adhesive — Neutral

A water dispersed, high-strength, non-flammable contact adhesive. Has high-coverage, a long-bonding range, and good heat resistance. Used to bond plastics, plastic laminate, wood, plywood and wood veneer and canvas to themselves and to each other.



Part Number	Container Size	Containers Per Case
021200- <b>21180</b>	Quart	12
021200- <b>21181</b>	Gallon	4
021200- <b>21182</b>	5 Gallon Pail	1
021200- <b>21183</b>	52 Gallon Drum (Open Head)	1

# Adhesives

## Scotch-Grip™ Industrial Adhesive 4491

A light tan, sprayable, fast drying adhesive with good resistance to plasticizer migration. Formulated to be a HAPS free and SCAQMD Rule 1168 compliant solvent based adhesive. Ideal for bonding many vinyl extrusions and sheeting. Bonds made with it exhibit high strength and resistance to weathering, water, oil and many solvents.

	Part Number	Container Size	Containers Per Case
NEW	021200-50046	5 Gallon Pail	5
NEW	021200-50047	55 Gallon Drum	1

## 3M™ Super 77 Adhesive (Bulk)

A bulk version of 3M Brand Super 77 Spray Adhesive. A high tack, high coverage, fast drying, transparent adhesive for permanently attaching foils, carpeting, many lightweight foams, paper, cardboard, felt, and cloth to painted or unpainted metals, wood, hardboard, and other base materials. Some of the features are: high coverage, aggressive high tack, and long bonding range. It provides high initial "grab" with sufficient open time to allow for positioning of materials.



	Part Number	Container Size	Containers Per Case
NEW	021200-43798	1 Gallon	4
NEW	021200-43793	5 Gallon Pail	5
NEW	021200-43813	55 Gallon Drum	1

## 3M™ Hi-Strength 90 Adhesive (Bulk)

A bulk version of 3M Brand Hi-Strength 90 Spray Adhesive. A high strength, fast, contact-type adhesive. It has fast contact strength buildup for many decorative laminates, yet only needs one or two minutes of drying time. Excellent adhesive for decorative laminates, particleboard, and many other materials, even polyethylene, polypropylene, and SBR rubber.



	Part Number	Container Size	Containers Per Case
NEW	021200-43799	1 Gallon	4
NEW	021200-43797	5 Gallon Pail	5
NEW	021200-43814	55 Gallon Drum	1

## 3M™ Scotch® Mini Weld Adhesive System

This product is a low cost, low temperature applied, thermosetting adhesive system, which is easy to use and portable. There are three main Mini Weld adhesive products, with two of them geared mainly for wood applications and the third being a general purpose product. As with its larger product sibling, Jet Weld, Mini Weld can be used to bond a wide variety of substrates including ABS, aluminum, acrylic, fabric, glass, leather, neoprene, melamine, PVC, polycarbonate, vinyl and wood.



	Part Number	Description	Size	Each Per Case
NEW	021200-49860	Multi-Purpose Adhesive 3481	30 ml Cartridge	6
NEW	021200-49861	Medium Set Wood Adhesive 3485	30 ml Cartridge	6
NEW	021200-49862	Fast Set Wood Adhesive 3489	30 ml Cartridge	6
NEW	021200-49863	Adhesive Starter Kit	Kit	1
NEW	021200-49891	Adhesive Starter Kit	Kit	5
NEW	021200-49864	Applicator with Plunger	Applicator	1
NEW	021200-49889	Applicator with Plunger	Applicator	5
NEW	021200-49865	Heater	Single Tube Unit	1
NEW	021200-49890	Heater	Single Tube Unit	5
NEW	021200-49866	Plunger	3/bag	1
NEW	021200-49867	Drip Cap	2/bag	1

# Aerosol Adhesives

## 3M™ Low Mist Super 77 Spray Adhesive

3M™ Low Mist Super 77 Spray Adhesive has been reformulated to reduce misting and VOC emissions while increasing adhesive coverage. A high-tack, high-coverage, fast-drying, transparent adhesive for permanently attaching foils, carpeting, foams, paper, cardboard, felt, cloth, etc. to painted or unpainted metals, wood, hardboard, and other base materials. Features: convenient, fast, easy application; high coverage, aggressive high tack, long bonding range; two actuators, one actuator for standard spray pattern, second actuator for wide spray pattern; excellent spray control, uniform spray coat, high initial "grab" with sufficient open time to allow for positioning of materials. Contains no methylene chloride, 1,1,1-trichloroethane or chlorofluorocarbons.



Part Number	Container Size	Cans Per Case
021200-21210	24 oz. Aerosol	12

## 3M™ Super 77™ Spray Adhesive

A high tack, high coverage, fast drying, transparent adhesive for permanently attaching foils, carpeting, many lightweight foams, paper, cardboard, felt and cloth to painted or unpainted metals, wood, hardboard and other base materials. Features: Convenient, fast, easy application; high coverage, aggressive high tack, long bonding range; excellent spray control, uniform spray coat, high initial "grab" with sufficient open time to allow for positioning of materials.



Part Number	Container Size	1/8 Pallet
021200-39240	24 fl. oz. Aerosol	84 Cans

## 3M™ High-Strength Adhesive 90

3M™ High-Strength Adhesive 90 is the fastest drying, high-strength aerosol contact adhesive that 3M offers. Drying in just one to two minutes, substrates that are to be bonded can be assembled faster for improved productivity. Bonds difficult substrates including: polyethylene, polypropylene, many other plastics. Comes with an adjustable tip that allows the selection of a 1 to 3 inch spray width to match any application requirement. Contains no methylene chloride, 1,1,1-trichloroethane or chlorofluorocarbons.



Part Number	Container Size	Cans Per Case
021200-30023	24 fl. oz. Aerosol	12

## 3M™ 76 High Tack Adhesive

A high-tack adhesive with fast strength build-up. Used by sailmakers when tacking parts of sails together prior to sewing. Apply to one surface. It comes out of the can in a "lace" spray for more control. Also attaches nameplates and swimming pool liners.



Part Number	Container Size	Cans Per Case
021200-30026	24 oz. Aerosol	12

## 3M™ Hi-Strength 90 Cylinder Spray Adhesive

3M™ Hi-Strength 90 Cylinder Spray Adhesive applies translucent adhesive in a controlled lace pattern. For two-surface bonding only. Bonding within 15 minutes is recommended. Forms a permanent bond with typical shear strength of 45 psi (initial) to 230 psi (ultimate) and peel strength of 25 piw. Can be used in construction, display assembly, furniture assembly/repair and general assembly tasks including the bonding of kick plates to office desks and plastic lettering to wood.



Part Number	Container Size	Each Per Case
021200-41554	47.7 lbs.	1
021200-41599	26.2 lbs.	1

## 3M™ Super 74 Foam Fast Adhesive

Excellent aerosol adhesive for general upholstery form bonding. Its characteristics include: fast tack; foam tearing strength; soft, non-dimpling glue line; non-misting; precise spray control and variable width spray. Applications include forming foam shapes by knife edge bonding, boxing and edge turning and attaching foam to metal. Contains no methylene chloride, 1,1,1-trichloroethane or chlorofluorocarbons.



Part Number	Container Size	Cans Per Case
021200-82242	24 fl. oz.	12

## 3M™ Super Foam Fast 74 Cylinder Spray Adhesive

3M™ Super Foam Fast 74 Cylinder Spray Adhesive bonds foam to itself or other materials including most fabrics, wood or metal. Fast tack and non-dimpling. Various spray widths, from 1" to 12" can be achieved.

Part Number	Container Size	Containers Per Case
NEW 021200-49158	47.7 lbs.	1

## 3M™ Industrial Spray Adhesive

3M™ Industrial Spray Adhesive is an economical, industrial grade, general purpose aerosol adhesive. It bonds a wide variety of lightweight materials including paper, cardboard, plastic films, foam, and fiberglass insulation.

Part Number	Container Size	Containers Per Case
NEW 021200-87998	24 oz.	12

# Retail Packaged Adhesive/Mechanical Repair Products

## 3M™ Super Glue Gel (Cyanoacrylate) — 6001

A clear, one-part adhesive gel that dries within minutes after joining to form strong, permanent bond between close-fitting, non-porous surfaces. Has good resistance to chemicals, water and lower-temperature extremes.



Part Number	Container Size	Containers Per Case
6001ES	2 Gram	12

## 3M™ Super Strength Adhesive — 6004

The all purpose adhesive for bonding glass, leather, lightweight metal, most plastics, rubber, vinyl, cloth, etc. Grabs immediately - no clamping - and is permanent. Water resistant and fast drying.



Part Number	Container Size	Containers Per Case
051131-50096	1 oz. Tube	12

## 3M™ Ultrapro™ Silicone Gasket

Designed to be used as a gasket material for valve covers, oil pans and other engine and transmission applications. Flexible at -20° to 600°F. Oxygen sensor safe. Low odor/non-corrosive. Oil resistant.



Part Number	Color	Container Size	Containers Per Case
051135-08700	Black	3.0 oz. Tube	12

## 3M™ Super Silicone Sealant

General purpose sealant. Oxygen sensor safe. Low odor.



Part Number	Color	Container Size	Containers Per Case
051135-08707	Blue	3.0 oz. Tube	12

## 3M™ Gasket Removal Disc

Quickly removes gasket residue. Conditions gasketing surface. Safer than wire brush or scraper.



Part Number	Size	Discs Per Case
051135-08710	- No Longer Available -	-

## 3M™ High-Strength Threadlocker — Red

Keeps threaded fasteners from loosening. Heavy-duty professional formula. Extreme temperature resistance up to 300°F. Heat required for disassembly. Ideal for 3/8" and larger fasteners.



Part Number	Color	Container Size	Containers Per Case
051135-08730	Red	0.34 oz.	12

## 3M™ Medium-Strength Threadlocker — Blue

Keeps threaded fasteners from loosening. General purpose applications. Extreme temperature resistance up to 300°F. Ideal for 1/4" to 1" fasteners.



Part Number	Color	Container Size	Containers Per Case
051135-08731	Blue	0.34 oz.	12

## 3M™ Pipe Sealant with Teflon®

Seals threaded fittings. Prevents leakage. Protects against corrosion. Repositionable for 48 hours.



Part Number	Container Size	Containers Per Case
051135-08740	0.2 oz. Tube	12

Teflon® is a registered trademark of DuPont.

## 3M™ Super Glue Gel

Professional strength formula. No-run gel – stays in place. Permanent bond in seconds. Bonds metal, rubber, plastic and more.



Part Number	Container Size	Containers Per Case
051135-08751	0.7 oz. Tube	12

## 3M™ Metal Repair Putty

Quick-cure formula. Can be drilled, sanded and filed. Bonds steel, aluminum, plastic and more. Withstands 300°F intermittent.



Part Number	Container Size	Containers Per Case
051135-08760	1.0 oz.	12

## 3M™ Dielectric Tune-up Grease

Protects electrical connections. Protects spark plug boot damage. Protects wiring from salt, dirt and corrosion.



Part Number	Container Size	Containers Per Case
051135-08770	- No Longer Available -	-

## 3M™ Anti-Seize Lubricant

Lubricates and prevents corrosion. High-temperature formula. Prevents seizing of spark plugs, cylinder head and exhaust bolts.



Part Number	Container Size	Containers Per Case
051135-08772	- No Longer Available -	-

# Command™ Adhesives

## 3M™ Command™ Adhesive Products

This unique revolutionary adhesive system enables boat consumers to mount objects firmly on many surfaces and remove them without damaging the surface or leaving behind any sticky adhesive residue. 3M™ Command™ Adhesive Products are available in hooks, clips and replacement strips for a wide variety of applications. Hooks for holding clothing, towels, etc. Clips for marine cables, wires and electronics. Poster strips for the mounting of flexible objects. Easy to apply and remove, firm holding power, removes cleanly.



65141



65142



65144



65594



65601



65987



65988



70532



70533



70534



70535



70536



70537



79713

## 3M™ Command™ Adhesive Products (cont.)

Part Number	Catalog Number	Description/ Size	Each Per Pack	Packs Per Case
051131-65141	17001	Medium Utility Hook 3.875 x 7.75 x 1.25	6	36
051131-65142	17003	Large Utility Hook 3.875 x 7.75 x 1.5	6	36
051131-65144	17021	Medium Hook Replacement Strips 3.875 x 7.75 x 1.88	6	36
051131-65594	17022	Large Hook Replacement Strips 3.875 x 7.75 x 1.88	6	36
051131-65601	17017	Wire Clips 3.875 x 7.75 x .438	6	36
051131-65987	17023	Wire Clip Replacement Strips 3.875 x 7.75 x .188	6	36
051131-65988	17024	Poster Strips 3.875 x 7.75 x .188	6	36
051131-66206	17003CS	Large Utility Hooks 12 Pack		12
051131-66207	17001CS	Medium Utility Hooks 12 Pack		12
051131-66208	17017CS	Wire Clip 12 Pack		12
051131-66209	17024CS	Poster Strips 12 Pack		12
051131-66313	17015	Wing Display Contains: 15 Each – 65142 30 Each – 65141		1
051131-70532	17002	Small Hook 7.75 x 3.876 x 1	6	36
051131-70533	17006	Mini Hooks 7.75 x 3.876 x .75	6	36
051131-70534	17004	Jumbo Hook 7.75 x 3.876 x 1.875	6	36
051131-70535	17005	Spring Clip 7.75 x 3.876 x 1	6	36
051131-70536	17040	Sawtooth Picture Hanger 7.75 x 3.876 x .5	6	36
051131-70537	17041	Wire-Backed Picture Hanger 7.75 x 3.876 x .5	6	36
051131-79713	17001GRY	Gray Medium Hooks 7.75 x 3.875 x 1.25	6	36

# Fastening Systems

## 3M™ Scotchmate™ Hook-and-Loop Reclosable Fastening System Mini Packs

3M™ Scotchmate™ Hook-and-Loop Reclosable Fastening System offers advanced closure alternatives to zippers, screws, snaps, hooks, bolts and more. They're often better than conventional closure methods because they offer greater design flexibility, faster product assembly, smoother and cleaner exterior surfaces and improved product performance.

The new Mini Packs are great for design development and small-volume production requirements. Now you can inexpensively test and evaluate 3M's most popular reclosable fastening systems before making a more substantial investment. Mini Packs also simplify storage and dispensing.

Available in Mini Packs are both plain backed sew-on and adhesive-backed fasteners which allow for faster, easier attachment. Pressure-sensitive adhesive-backed versions include both general purpose and very-high-bond VHB adhesives.

## 3M™ Scotchmate™ Hook-and-Loop Fasteners: Mini Packs

(Roll Size is 1" x 4.9 yds./1 roll each of both sides included.)  
There are 5 rolls per case.

Part Number	Product/ Color	Description	Temperature
051131-06464	MP-3401/02 White	Sew-on 3M™ Scotchmate™	250°F Continuous
051131-06465	MP-3401/02 Black	Sew-on 3M™ Scotchmate™	250°F Continuous
051131-06481	MP-3526/27 Black	General Purpose Pressure-Sensitive Rubber Adhesive/ Bonds to Most Surfaces	120°F Continuous 158°F Intermittent
051131-06488	MP-3526/27 White	General Purpose Pressure-Sensitive Rubber Adhesive/ Bonds to Most Surfaces	120°F Continuous 158°F Intermittent

## 3M™ Scotchmate™ Hook-and-Loop Fasteners

3M™ Scotchmate™ Fasteners described here consist of two woven strips, one of which is covered with tiny, stiff hooks and the other with pliable loops. Pressed together they fasten; to open, simply pull apart.



- Plain Backed** — SJ3401 Loop and SJ3402 Hook
- Standard Sew-On** — Sew-on woven components are durable adjustable as well as completely washable.
- Pressure-Sensitive** — SJ 3526 Hook and SJ3527 Loop  
— SJ3571 Loop and SJ3572 Hook

This adhesive-backed product is designed for dynamic and static load applications on smooth, clean, and dry surfaces. It offers a high-adhesive bond to a wide variety of materials and are recommended for most pressure-sensitive applications. They also offer superior moisture resistance. The SJ3526 and SJ3527 when used for static load applications temperature should not exceed 120°F. The SJ 3571 and SJ3572 is designed for static load applications where temperatures may reach 200°F.

Part Number	Product Number	Color	Size	Rolls Per Case
021200-62640	SJ3401 LOOP	White	3/4" x 50 yds.	16
021200-62539	SJ3401 LOOP	White	1" x 50 yds.	12
021200-62545	SJ3401 LOOP	White	2" x 50 yds.	6
021200-62536	SJ3401 LOOP	Black	3/4" x 50 yds.	16
021200-62538	SJ3401 LOOP	Black	1" x 50 yds.	12
021200-62544	SJ3401 LOOP	Black	2" x 50 yds.	6
021200-62535	SJ3401 LOOP	Beige	3/4" x 50 yds.	16
021200-62537	SJ3401 LOOP	Beige	1" x 50 yds.	12
021200-62543	SJ3401 LOOP	Beige	2" x 50 yds.	6
021200-62551	SJ3402 HOOK	White	3/4" x 50 yds.	16
021200-62554	SJ3402 HOOK	White	1" x 50 yds.	12
021200-62560	SJ3402 HOOK	White	2" x 50 yds.	6
021200-62550	SJ3402 HOOK	Black	3/4" x 50 yds.	16
021200-62553	SJ3402 HOOK	Black	1" x 50 yds.	12
021200-62559	SJ3402 HOOK	Black	2" x 50 yds.	6
021200-62549	SJ3402 HOOK	Beige	3/4" x 50 yds.	16
021200-62552	SJ3402 HOOK	Beige	1" x 50 yds.	12
021200-62558	SJ3402 HOOK	Beige	2" x 50 yds.	6
021200-86241	SJ3526 HOOK	White	5/8" x 50 yds.	4
021200-86244	SJ3526 HOOK	White	1" x 50 yds.	3
021200-86247	SJ3526 HOOK	White	2" x 50 yds.	2
021200-86240	SJ3526 HOOK	Black	5/8" x 50 yds.	4
021200-86243	SJ3526 HOOK	Black	1" x 50 yds.	3
021200-86245	SJ3526 HOOK	Black	2" x 50 yds.	2
021200-86239	SJ3526 HOOK	Beige	5/8" x 50 yds.	4
021200-86242	SJ3526 HOOK	Beige	1" x 50 yds.	3
021200-86246	SJ3526 HOOK	Beige	2" x 50 yds.	2
021200-86250	SJ3527 LOOP	White	5/8" x 50 yds.	4
021200-86253	SJ3527 LOOP	White	1" x 50 yds.	3
021200-86256	SJ3527 LOOP	White	2" x 50 yds.	2
021200-86249	SJ3527 LOOP	Black	5/8" x 50 yds.	4
021200-86252	SJ3527 LOOP	Black	1" x 50 yds.	3
021200-86255	SJ3527 LOOP	Black	2" x 50 yds.	2
021200-86248	SJ3527 LOOP	Beige	5/8" x 50 yds.	4
021200-86251	SJ3527 LOOP	Beige	1" x 50 yds.	3
021200-86254	SJ3527 LOOP	Beige	2" x 50 yds.	2
021200-86285	SJ3571 LOOP	Black	1" x 50 yds.	3
021200-86286	SJ3572 HOOK	Black	1" x 50 yds.	3

# Fastening Systems

## 3M™ Marine Reclosable Attachment System

Five times stronger than conventional hook-and-loop fasteners. Industrial strength adhesive holds backing securely in place. Use for attaching marine electronics. Secure boat cushions, floor mats or mount pictures on cabin walls. Keeps loose items secure until they are needed.



Part Number	Size	Each Per Case
<b>Carded</b>		
051135- <b>06539</b>	Four 3" strips	12 blister cards per case

## 3M™ Scotchmate™ Hook-and-Loop Fastening System

The 3M™ Scotchmate™ Hook-and-Loop Fastening System is comprised of two, 1" x 12" woven nylon strips, one strip of hook material and one of loop material, that mate together to hold items securely in place. Each strip is backed with a premium quality pressure-sensitive adhesive that is designed to meet the high and low temperature demands encountered in marine applications. Each 3M™ Scotchmate™ Hook-and-Loop package contains 12 mated strips and can be used for counter or pegboard display.



Part Number	Size	Each Per Box	Boxes Per Case
051131- <b>06480</b>	1" x 12" Mated Strips	12	6

## 3M™ Dual Lock™ Reclosable Fasteners

3M™ Dual Lock™ Fasteners described here consist of two types of continuous plastic strips (Type 400 and Type 170) with mushroom shaped stems. They are designed to engage together one with another to provide reclosable fastening for a wide range of applications.



3M™ Dual Lock™ 400 has a dense stem pattern of approximately 400 stems/sq. in. Mating this product with 3M™ Dual Lock™ Type 170 provides the most universal fastener combination in the 3M™ Dual Lock™ System. It locks together in any position and is generally the best choice for joining two surfaces when using the Pressure-Sensitive 3M™ Dual Lock™ products.

3M™ Dual Lock™ 170 has approximately 170 stems/sq. in. Besides general use with 3M™ Dual Lock™ Type 400 it can also be mated with 3M™ Scotchmate™ Loop products to provide an exceptional high-strength fastener with a limited reclosure life.

## 3M™ Plain Backed Dual Lock™ Reclosable Fasteners — SJ-3441 Type 400 — SJ-3442 Type 170

Plain Backed (no adhesive) 3M™ Dual Lock™ products are intended for attachment to various surfaces by sewing or by ultrasonic bonding to themselves, each other, or other polypropylene surfaces.

## 3M™ Pressure-Sensitive Backed General Purpose Dual Lock™ Reclosable Fasteners — SJ-3541 Type 400 — SJ-3542 Type 170

Designed for general purpose kinds of dynamic and static load applications where temperatures do not exceed 120° F. When applied under normal conditions, high adhesive bonds can be achieved to a wide variety of clean, dry surfaces including difficult surfaces like polyethylene and polypropylene.

## 3M™ Premium Performance Dual Lock™ Reclosable Fasteners — SJ-3551 Type 400 — SJ-3552 Type 170

High adhesive bonds can be achieved to a variety of surfaces, including paint, metal, and most plastics (except polyethylene or polypropylene). Special performance characteristics include:

- Good temperature and humidity cycling from -20° F to +200° F and 0% to 100% relative humidity.
- Good low and high temperature impact resistance at 20° F to 158° F.

Part Number	Product Number	Color	Size	Rolls Per Case
021200- <b>86229</b>	SJ3441	Black	1" x 50 yds.	2
021200- <b>86230</b>	SJ3442	Black	1" x 50 yds.	2
021200- <b>86277</b>	SJ3541	Black	1" x 50 yds.	2
021200- <b>86309</b>	SJ3542	Black	1" x 50 yds.	2
021200- <b>86278</b>	SJ3551	Black	1" x 50 yds.	2
021200- <b>86279</b>	SJ3552	Black	1" x 50 yds.	2



# Fastening Systems

## 3M™ Dual Lock™ Reclosable Fastening System Mini Packs

3M™ Dual Lock™ Reclosable Fastening System offers advanced closure alternatives to zippers, screws, snaps, hooks, bolts and more. They're often better than conventional closure methods because they offer greater design flexibility, faster product assembly, smoother and cleaner exterior surfaces and improved product performance.



The new Mini Packs are great for design development and small-volume production requirements. Now you can inexpensively test and evaluate 3M's most popular reclosable fastening systems before making a more substantial investment. Mini Packs also simplify storage and dispensing.

Available in Mini Packs are both plain backed sew-on and adhesive-backed fasteners which allow for faster, easier attachment. Pressure-sensitive adhesive-backed versions include both general purpose and very-high-bond VHB adhesives.

Roll size is 1" x 4.9 yds./1 roll each of both sides included. There are 5 rolls per case.

Part Number	Product/ Color	Description	Temperature
051131- <b>06483</b>	MP-3541/42	General Purpose	120° F
	Black 3M™ Dual Lock™ Fasteners	Pressure-Sensitive Rubber Adhesive/ Bonds to Most Surfaces	Continuous 158° F Intermittent
051131- <b>06484</b>	MP-3551/52	Premium Acrylic Pressure-Sensitive	Up to 200° F
	Black 3M™ Dual Lock™ Fasteners	Very-High-Bond Scotch™ VHB Adhesive UV and Plasticizer Resistant	
051131- <b>06463</b>	MP-3560	New "Clear"	Up to 200° F
	Clear 3M™ Dual Lock™ Fasteners	3M™ Dual Lock™ Very-High-Bond Scotch™ VHB Adhesive UV and Plasticizer Resistant	

# Lubricants

## 3M™ Penetrant

3M™ Penetrant is a deep penetrating lubricant which frees rusted bolts, nuts, screws, and other mechanical fasteners. Also, it lubricates and protects against corrosion. Special spray tip actuator produces a straight shot spray pattern, minimizing overspray.



Part Number	Container Size	Cans Per Case
051135-08876	16 oz. Aerosol	12

## 3M™ 4-Way™ Spray Lubricant

A specialized formula for general or all-around use. It provides characteristics of a lubricating oil, a penetrating oil and a demisterizing coating. A thin-bodied, transparent rust-preventative coating. Contains no silicone.



Part Number	Container Size	Cans Per Case
051135-08898	16 oz. Aerosol	12

## 3M™ Lithium Lubricant

A heavy bodied lubricant with snorkel spray for hard-to-get-at areas. Excellent on all metal-to-metal parts.



Part Number	Container Size	Cans Per Case
051135-08875	16 oz. Aerosol	12

## 3M™ Silicone Lubricant

Use 3M™ Silicone Lubricant to lubricate moving parts; eliminate squeaks caused by friction; prevent sticking and freezing; protect against rust and corrosion; seal out moisture; preserve plastic, rubber, leather; help prevent build up of glues, waxes, inks, paints, etc. Each can comes with a handy snorkel tube for small, hard-to-reach areas. It slips easily into the spray nozzle. Contains no methylene chloride, 1,1,1-trichloroethane or chlorofluorocarbons.



Part Number	Container Size	Cans Per Case
021200-85822	24 fl. oz. Aerosol	12

## 3M™ Silicone Lubricant Plus (Wet Type)

A high solids silicone lubricant that provides a long "wet" appearance and increases sliding or lubricating qualities.



Part Number	Container Size	Cans Per Case
051135-08877	16 oz. Aerosol	12

## 3M™ Spray Lube

3M™ Spray Lube is a clear fluid, high-performance, general purpose grease. It is designed to be water resistant. 3M™ Spray Lube can be used to lubricate many items including hinges, latches and seat tracks. 3M™ Spray Lube flows as a liquid then sets up to a uniform coating of grease.



Part Number	Container Size	Cans Per Case
051135-08878	16 oz. Aerosol	12

## 3M™ Brake Lube/Anti-Seize

3M™ Brake Lube/Anti-Seize is a premium grade lubricant designed to prevent the seizure of close fitting metal parts. 3M™ Brake Lube/Anti-Seize Compound is resistant to high temperatures and designed to be used in critical applications such as lubricating brake parts, head bolts, spark plugs, oxygen sensors and most threaded fasteners.



Part Number	Container Size	Cans Per Case
051135-08945	8 oz. Can	6

## 3M™ Silicone Paste

3M™ Silicone Paste is a 100% solid compound that is resistant to water and prevents oxidation on rubber or plastic parts such as weatherstrips, "O" rings, and rubber bushings. It can also be used to seal ignition systems. It has very good dielectric properties.



Part Number	Container Size	Cans Per Case
051135-08946	8 oz. Can	6

## 3M™ Choke and Carb Cleaner

Penetrates quickly to loosen and clean away varnish, oil and gum. Has fast-cleaning action plus a powerful spray to flush away residue. Dries fast and may be used on cold, hot or running engines.



Part Number	Container Size	Cans Per Case
051135-08796	16 oz. Aerosol	12

# Paint & Varnish Remover & Accessories

## 3M™ Safest Stripper™ Paint & Varnish Remover

A revolutionary paint and varnish stripper that can be applied without gloves; just brush on a thick coat. It contains no methylene chloride fumes, non-caustic, no unpleasant odors, non-flammable and cleans up easily with water. Great for below deck applications where fumes can be a nuisance.



Part Number	Container Size	Containers Per Case
051111-10101	Quart	6
051111-10102	- No Longer Available -	
051111-10103	Gallon	2

## 3M™ Heavy Duty Stripping Pads (For Flat Surfaces)

The pads won't splinter, rust or shred like steel wool. They replace and outperform #2 and #3 steel wool. Ideal for Marine applications.



Part Number	Size	Pads Per Package	Packages Per Case
051111-10111	3-1/2" x 5" x 1/2"	2	12

## 3M™ Heavy Duty Stripping Pads (Flexible for Curved Surfaces)

These pads provide aggressive stripping action, great on curved or rounded marine surfaces. They replace and outperform #2 steel wool.



Part Number	Size	Pads Per Package	Packages Per Case
051111-10112	6" x 3-7/8"	2	12

## 3M™ Final Stripping Pads (For Residue Removal)

Use these pads to thoroughly clean marine surfaces of any remaining stripper residue. This pad replaces "0" steel wool.



Part Number	Size	Pads Per Package	Packages Per Case
051111-10113	6" x 3-7/8"	2	12

# 3M™ Respirators for Marine Applications



Worker Safety and comfort are two of the main concerns in the development of all 3M safety products. Whenever workers perform duties in environments that require the use of respiratory protection and other safety products, we can provide the products you need and help you meet, or exceed, applicable OSHA regulations.

Managers and workers know that a good safety program can also have a positive effect on performance. Safety and health regulations require that workers be informed about safety practices and specific respirator usage. As workers learn the health benefits of wearing proper respiratory protection, they may be more likely to accept safety equipment as part of the job.

Here are some of the features and advantages of 3M products:

- Comfortable fit. Lightweight, easy-to-wear.
- Minimum maintenance. Simply dispose of respirator or cartridge/filter when used to capacity. 3M low-maintenance respirators are designed to require minimum care.

- Fit flexibility. 3M respirators fit a variety of different face sizes and shapes. Assessment of a proper fit must be determined for each respirator user through an appropriate fit test.
- Better visibility. Low profile designs permit greater visibility even with eye and face protection in place.

<b>WARNING</b>	
	<p>These respirators help reduce exposure to certain airborne contaminants. <b>Misuse may result in sickness or death.</b> Before use, the wearer must read and understand User Instructions provided as part of product packaging. Call 3M OH&amp;ESD Technical Service at 1-800-243-4630.</p> <p><b>Important</b> Before using these respirators, you must determine the following:</p> <ol style="list-style-type: none"> <li>1. The type of contaminant(s) for which the respirator is being selected.</li> <li>2. The concentration level of contaminant(s).</li> <li>3. Whether the respirator can be properly fitted on the wearer's face. All respirators instructions, warnings and use and time limitations must also be read and understood by the wearer before use.</li> </ol>

## Marine Respirator Selection Information Applications

Respiratory Type	Bottom Paint Stripping/Sanding	Bottom Paint Stripping/Sanding/Lead Based	Sanding Gelcoat/Fiberglass	Sanding Woods	Sanding Epoxies	Applying Bottom Paints (Brush)	Spray Painting with Enamels	Spray Painting with Polyurethanes	Applying and Mixing 2-pint Epoxies	Welding – Steel	Welding (Zinc Oxide)	Welding Stainless, Galvanized	Exposures to Gases and Vapors	Acid Etching/Cleaning	Chemical/Power Washing	Confined Space Entry	Response
3M™ Particulate Respirators N95	X		X	X	X												
3M™ Particulate Respirators with Nuisance Level Protection*			X		X												
3M™ Particulate Respirators Recommended for Welding Applications										X	X	X					
3M™ Particulate Respirators P100 Recommended for Lead Exposures		X								X	X	X					
3M™ Dual Cartridge Half Facepiece Respirators	X	X	X	X	X	X	X	X	X	X	X	X	X	X	X		
3M™ Dual Cartridge Full Facepiece Respirators	X	X	X	X	X	X	X	X	X	X	X	X	X	X	X		
3M™ Supplied Air Respirators High and Low Pressure	X	X	X	X	X	X	X	X	X	X	X	X	X	X	X		
3M™ Powered Air Respirators	X	X	X	X	X	X	X	X	X	X	X	X	X	X	X		
3M™ Self Contained Breathing Apparatus (SCBA)																X	X

\* NUISANCE LEVEL REFERS TO CONCENTRATIONS NOT EXCEEDING OSHA PEL OR APPLICABLE GOVERNMENT OCCUPATIONAL EXPOSURE LIMITS, WHICHEVER IS LOWER.

# 3M™ Respirators

## Filtering Facepiece Particulate Respirators

Excellent worker protection in a wide variety of applications. Because they are comfortable to wear and easy to use, workers are quick to accept and use maintenance-free respirators.

### 3M™ Particulate Respirator 8210, N95

Lightweight construction.

- Promotes greater worker comfort.
- Contributes to increased wear time.

Adjustable noseclip.

- Provides a custom fit and more secure seal.
- Reduces the potential for eyewear fogging.

All filter design.

- Provides economic protection.
- No spare parts to clean and maintain.
- Promotes easier communication.



Part Number	Respirators Per Box	Boxes Per Case
8210	20	8

### 3M™ Particulate Respirator 8110S, N95 (size small)

Smaller version of the 3M™ 8210, N95 Respirator.



Part Number	Respirators Per Box	Boxes Per Case
8110S	20	8

### 3M™ Particulate Respirator 8511, N95

The 3M™ Cool Flow™ Exhalation Valve reduces heat and humidity build up inside the respirator. Wearers will appreciate the added comfort and durability found in this respirator. The innovative M-noseclip helps provide a good seal against the face.



Part Number	Respirators Per Box	Boxes Per Case
8511	10	8

### 3M™ Particulate Respirator 8211, N95

The 3M™ Cool Flow™ Exhalation Valve reduces heat and humidity build up inside the respirator. The faceseal ring promotes comfort and fit over a broad range of face sizes. The innovative M-noseclip helps provide a good seal against the face.



Part Number	Respirators Per Box	Boxes Per Case
8211	10	8

### 3M™ Particulate Respirator 9210, N95

Innovative Three Panel design.

- Low profile for better visibility.
- Conforms to a wide range of face sizes.
- Soft, conformable noseclip adjusts easily for custom fit and secure feel.



Individually Packaged

- Convenient storage and portability prior to use.
- Increased worker acceptance.

Part Number	Respirators Per Box	Boxes Per Case
9210	20	12

### 3M™ Particulate Respirator 9211, N95

Three panel respirator featuring 3M™ Cool Flow™ Exhalation Valve for comfort in hot, humid applications.

- Low profile.
- Conforms to a wide range of face sizes.
- Soft, conformable noseclip adjusts easily for custom fit and secure feel.



Individually Packaged

- Prevents contamination during storage.
- Allows for easy dispensing.

Part Number	Respirators Per Box	Boxes Per Case
9211	10	12

### 3M™ Particulate Respirator 8271, P95

This respirator is NIOSH approved to have at least 95% filter efficiency against solid and liquid particles. Uses include grinding, sanding, sawing in either oil or non-oil environments. This product comes with the conformable M-noseclip which helps provide a good fit, 3M™ Cool Flow™ Exhalation Valve to reduce heat and moisture inside the respirator, and a faceseal ring which promotes comfort and fit over a broad range of face sizes.



Part Number	Respirators Per Box	Boxes Per Case
8271	10	8

# 3M™ Respirators

## Specialty Filtering Facepiece Particulate Respirators

### 3M™ Particulate Respirator 8247, R95

This respirator is 3M recommended for nuisance level\* organic vapor relief. For use in applications where particles are present with concentrations of organic vapors below the OSHA PEL.



Part Number	Respirators Per Box	Boxes Per Case
8247	20	6

### 3M™ Particulate Respirator 8577, P95, with Nuisance Level Organic Vapor Relief

This respirator is NIOSH approved to have at least 95% filter efficiency against solid and liquid particles, including oil particles. Recommended for use in environments where relief from nuisance levels\* of organic vapors may be desired. The respirator incorporates the 3M™ Cool Flow™ Exhalation Valve and M-noseclip which enhance the comfort, fit and durability of the respirator.



Part Number	Respirators Per Box	Boxes Per Case
8577	10	8

### 3M™ Particulate Respirator 8246, R95

This respirator is 3M recommended for nuisance level acid gas relief such as hydrogen fluoride, sulfur dioxide and chlorine. Not to be used in situations where the exposure exceeds the OSHA PEL.



Part Number	Respirators Per Box	Boxes Per Case
8246	20	6

### 3M™ Particulate Respirator 8576, P95, with Nuisance Level Acid Gas Relief

This respirator is NIOSH approved to have at least 95% filter efficiency against solid and liquid particles, including oil particles. Recommended for use in environments where relief from nuisance levels\* of acid gases such as hydrogen fluoride, hydrogen chloride, sulfur dioxide and chlorine may be desired. The respirator incorporates the 3M™ Cool Flow™ Exhalation Valve and M-noseclip which enhance the comfort, fit and durability of the respirator.



Part Number	Respirators Per Box	Boxes Per Case
8576	10	8

### 3M™ Particulate Respirator 8233, N100

For those who want maximum filter efficiency in a maintenance free respirator, this product has been approved by NIOSH to provide at least 99.97% filter efficiency against solid and liquid particles (excluding those containing oil). This respirator can be used when grinding, welding, working with lead, or situations where arsenic or cadmium are present up to 10X the OSHA PEL. Value added features such as adjustable straps, 3M™ Cool Flow™ Exhalation Valve and a conformable face seal make this a comfortable, durable respirator. Not to be used for asbestos exposure.



Part Number	Respirators Per Bag	Bags Per Case
8233	1	20

### 3M™ Particulate Respirator 8293, P100

For use where the following OSHA substance specific standards apply:

- Lead
- Cadmium
- Arsenic
- 4, 4 – Methylene dianilins (MDA)



P rated for protection against liquid or oil based particles from sprays that do not also emit harmful vapors.

Value added features include adjustable straps, 3M™ Cool Flow™ Exhalation Valve and soft face seal for comfortable secure fit.

Part Number	Respirators Per Box	Boxes Per Case
8293	1	20

\* Nuisance Level refers to concentrations not exceeding OSHA PEL or applicable government exposure limits, whichever is lower.

# 3M™ Respirators

## 3M Filtering Facepiece Particulate Respirators Recommended for Welding Applications

3M offers high quality respirators for welding and other metal fume environments. Our filtering facepiece respirators are compatible with welding hoods, faceshields and safety glasses. 3M technologies, described below, provide for better performance in welding and related functions.

### 3M™ Particulate Welding Respirator 8515, N95

- 3M™ Cool Flow™ Exhalation Valve improves comfort.
- M-noseclip adjusts for fewer pressure points and greater comfort.
- Black valve distinguishes the respirator.
- Braided headband provides comfort and durability.



Part Number	Respirators Per Box	Boxes Per Case
8515	10	8

### 3M™ Particulate Welding Respirator 8512, N95

- Helps provide a custom, secure seal and longer respirator life.
- 3M cake-resistant filter media.
- Wide adjustable straps.
- Features 3M welding web and 3M™ Cool Flow™ Exhalation Valve.



Part Number	Respirators Per Box	Boxes Per Case
8512	10	8

### 3M™ Particulate Welding Respirator 8212, N95, with Faceseal

This respirator is designed for use when welding, torch cutting, soldering, brazing and working with molten metals. Fits easily under a welding hood. Adjustable straps, faceseal, and 3M™ Cool Flow™ Exhalation Valve provide added comfort and durability. Cake-resistant filter media construction allows for easier breathing.



Part Number	Respirators Per Bag	Boxes Per Case
8212	10	8

### 3M™ Particulate Welding Respirator 8514, N95, with Nuisance Level Organic Vapor Relief

- Helps provide 3M recommended protection against ozone up to 10X PEL.
- Wide adjustable straps.
- Features 3M cake-resistant filter media, and 3M™ Cool Flow™ Exhalation Valve.



Part Number	Respirators Per Box	Boxes Per Case
8514	10	8

### 3M™ Particulate Welding Respirator 8214, N95, with Faceseal and Nuisance Level Organic Vapor Relief

Helps provide 3M recommended protection against ozone up to 10X PEL. Removes nuisance level (below OSHA PEL) organic vapors and odors. 3M™ Cool Flow™ Exhalation Valve improves comfort and adjustable straps and faceseal ring provide secure face fit.



Part Number	Respirators Per Bag	Boxes Per Case
8214	10	8

\* Nuisance Level refers to concentrations not exceeding OSHA PEL or applicable government exposure limits, whichever is lower.

For additional products for welding applications, also see 3M™ Respirator Packouts:

6000 Series P100 Respirators (page 151)

- 6191
- 6291
- 6391



3M™ Particulate Filter 2091, P100 (page 153)



3M™ Particulate Filter 2097, P100, with Nuisance Level Organic Vapor Relief (page 150, 153)

3M™ Particulate Filter 7093, P100 (page 154)



3M™ Full Facepiece Respirators with Welding Faceshields (page 152, 154)

3M™ Fresh Air Systems with Welding Hoods (page 155)



# 3M™ Respirators

## Half Facepiece Respirators 5000 Series Disposable

### 3M™ Dual Cartridge Respirator Assembly 5XP71, Organic Vapor/P95

(3M recommended for paint spray and pesticide applications)

This NIOSH approved disposable respirator offers a new level of comfort and protection in painting applications. It is available in three convenient sizes designed to fit the majority of workers. For convenience, respirator assemblies are packaged with one pair of 3M™ Particulate Filters 5P71, P95 and one pair of 3M™ Retainers 501.



Part Number	Description	Respirators Per Package	Packages Per Case
51P71	Small Organic Vapor / P95 Respirator Assembly	1	12
52P71	Medium Organic Vapor / P95 Respirator Assembly	1	12
53P71	Large Organic Vapor / P95 Respirator Assembly	1	12

### 3M™ Respirator Assembly Organic Vapor/P100

This assembly is NIOSH approved for respiratory protection against certain organic vapors, dusts, asbestos-containing dusts and fumes found in today's marine environment. Replaceable P100 filters provide longer life and greater economy to the respirator assembly.



Part Number	Description	Respirators Per Box	Boxes Per Case
51911	Small Respirator	1	12
52911	Medium Respirator	1	12
53911	Large Respirator	1	12

Part Number	Description	Filters Per Package	Packages Per Case
<b>Replacement Parts</b>			
2091	P100 Filter	2	50

### 3M™ Organic Vapor Respirator Assembly

- Disposable Organic Vapor Respirators.
- Low profile design for wider field of vision and greater comfort.
- Lightweight design with cradle suspension.
- Available in 3 sizes for best worker fit and comfort.



Part Number	Description	Respirators Per Package	Packages Per Case
5101	Small Organic Vapor Respirator	1	12
5201	Medium Organic Vapor Respirator	1	12
5301	Large Organic Vapor Respirator	1	12

### 3M™ Respirator Assembly Organic Vapor/Acid Gas/P100

This assembly is NIOSH approved for respiratory protection against certain organic vapors, sulfur dioxide, hydrogen chloride, hydrogen fluoride, chlorine, dusts, asbestos-containing dusts, fumes and mists. Its innovative design requires no maintenance and provides greater worker comfort. It also features the use of replaceable P100 filters which provide longer life and greater economy to the respiratory assembly.



Part Number	Description	Respirators Per Box	Boxes Per Case
51913	Small Respirator Assembly	1	12
52913	Medium Respirator Assembly	1	12
53913	Large Respirator Assembly	1	12

### 3M™ Multi Gas and Vapor Respirator Assembly

This half facepiece assembly provides the utmost in simplicity and comfort. The respirator is lightweight, well-balanced, and comes in 3 color-coded sizes for quick identification. The swept-back cartridge design enhances balance, comfort, safety and vision. The respirator comes preassembled and has no spare parts and requires no maintenance.



Part Number	Description	Respirators Per Box	Respirators Per Case
5106	Small Respirator	1	12
5206	Medium Respirator	1	12
5306	Large Respirator	1	12

3M™ Replacement Filters and Accessory items for the 5000 Maintenance Free Series Respirators are found listed with the 6000 Low Maintenance Free and 7500 Series Replacement Cartridge Style Respirator Accessories.

## WARNING



These respirators help reduce exposure to certain airborne contaminants. **Misuse may result in sickness or death.** Before use, the wearer must read and understand User Instructions provided as part of product packaging. Call 3M OH&ESD Technical Service at 1-800-243-4630.

### Important

Before using these respirators, you must determine the following:

1. The type of contaminant(s) for which the respirator is being selected.
2. The concentration level of contaminant(s).
3. Whether the respirator can be properly fitted on the wearer's face. All respirators instructions, warnings and use and time limitations must also be read and understood by the wearer before use.



# 3M™ Respirators

## Half Facepiece Respirators 6000 and 7500 Series and Packouts

### 3M™ Professional Respirator 7500 Series

These respirators are exceptionally comfortable, durable and easy to use. With a face seal of an advanced liquid silicone material providing a softer feel on the face, a unique head suspension to reduce tension and pressure points and the 3M™ Cool Flow™ Exhalation Valve for reduced breathing resistance, the Professional Series is the most comfortable respirator available. Convertible from a conventional style suspension to a drop-down mode in one simple adjustment makes it the versatile choice for workers who wear hard hats.



	Part Number	Description	Facepieces Per Bag	Bags Per Case
NEW	7501/37081	Small Facepiece	1	10
NEW	7502/37082	Medium Facepiece	1	10
NEW	7503/37083	Large Facepiece	1	10

### 3M™ Half Facepiece Respirators 6000 Series Reusable

This is a NIOSH approved half facepiece respirator that is adaptable to a wide range of respiratory protection. Its low maintenance, comfortable design allows greater worker flexibility by the use of different type cartridges and filters for a variety of work environments. Cartridges are simply twisted on or off of the facepiece for easy replacement which allows the facepiece to be used over and over. The facepiece is easy to clean and is supplied with a storage bag. Read all product instructions and warnings prior to use.



	Part Number	Description	Facepieces Per Bag	Bags Per Case
	6100/07024	Small Facepiece	1	24
	6200/07025	Medium Facepiece	1	24
	6300/07026	Large Facepiece	1	24

### 3M™ Half Facepiece Respirators 6000 Series Drop Down

This respirator is the latest innovation in half facepiece design. It incorporates a unique drop-down head harness system so those workers leaving the contaminated area can more easily communicate without totally removing the respirator. Designed for workers who wear hard hats or hard hats with liftable faceshields. With this system, the facepiece drops straight down onto the chest by detaching the neck strap. The key advantages are: easy communication without having to undo their personal protection equipment, exhalation valve better protected by strap and cradle cover allowing for safer work and versatility in design. Can be used with 3M™ 2000 Series, 6000 Series, and 7093 Filters, Cartridges, and Accessories.



	Part Number	Description	Facepieces Per Bag	Bags Per Case
	6100DD	Small Facepiece	1	24
	6200DD	Medium Facepiece	1	24
	6300DD	Large Facepiece	1	24

### 3M™ Half Facepiece Respirators Professional Series, Organic Vapor/P95 Packout

This packout is 3M recommended for paint spray applications. Packouts include: one 3M™ Professional Half Facepiece 7500 Series, two 3M™ Organic Vapor Cartridges 6001, four 3M™ Particulate Filters 5P71, P95 and two 3M™ Retainers 501.



	Part Number	Description	Packouts Per Case
NEW	051131-37077	Small Respirator Packout	4
NEW	051131-37078	Medium Respirator Packout	4
NEW	051131-37079	Large Respirator Packout	4

### 3M™ Professional Series Half Facepiece Respirator Rebuild Kit

Includes replacement parts to maintain the durable respirator facepiece.



	Part Number	Description	Packouts Per Case
NEW	051131-37080	Kit	5

# 3M™ Respirators

## Maintainable Half Facepiece Dual Cartridge Respirators and Packouts

### 3M™ Half Facepiece Respirators, 6000 Series, Organic Vapor/P95 Packout

This packout is NIOSH approved for organic vapors and is 95% efficient in removing solid and liquid particles including oils. 3M suggested for spray painting lacquer, enamel and pesticides. This packout has a reusable design – changeable filters and cartridges. Packout includes: one 3M™ Half Facepiece 6000 Series Reusable, two 3M™ Organic Vapor Cartridges 6001, four 3M™ Particulate Filters 5P71, P95 and two 3M™ Filter Retainers 501.



Part Number	Description	Packouts Per Case
051131-07177	Small Respirator Packout	4
051131-07178	Medium Respirator Packout	4
051131-07179	Large Respirator Packout	4

### 3M™ Half Facepiece Respirators, 6000 Series P100 Packout

This packout features worker comfort and convenience. It comes with two replaceable 3M™ Particulate Filters 2091, P100. It is NIOSH approved against dusts, fumes, mists and asbestos containing dusts and mists, up to 10X the PEL. The lightweight and comfortable features make this respirator ideal for sanding and grinding operations found in many marine applications. It is not to be used in paint spray operations.



Part Number	Description	Respirators Per Bag	Bags Per Case
6191/07001	Small Respirator Packout	1	24
6291/07002	Medium Respirator Packout	1	24
6391/07003	Large Respirator Packout	1	24

# 3M™ Respirators

## Full Facepiece Respirators and Packouts. Replacement Cartridges and Filters

### 3M™ Full Facepiece Respirator 6000 Series Reusable

This respirator is a lightweight balanced respirator. It has a soft, lightweight facepiece material, three facepiece sizes and easy-to-adjust headstraps to allow maximum comfort. This respirator requires only limited maintenance time. Just clean as directed between uses. No retainers or extra parts are required to attach filters, cartridges or dual airline. NIOSH approved.



Part Number	Description	Respirators Per Box	Boxes Per Case
6700	Small Facepiece	1	4
6800	Medium Facepiece	1	4
6900	Large Facepiece	1	4

### 3M™ Full Facepiece Respirators Organic Vapor/P95 Packout

This packout is NIOSH approved and 3M recommended for spray painting lacquer, enamel and pesticides. It has a reusable design with changeable filters and cartridges. Affords eye and respiratory protection. NIOSH approved for organic vapors and 95% efficient in removing solid and liquid particles including oils. Packout includes: one 3M™ Full Facepiece Respirator 6000 Series Reusable; two 3M™ Organic Vapor Cartridges 6001; four 3M™ Particulate Filters 5P71, P95; two 3M™ Retainers 501 and two 3M™ Faceshield Covers 6885.



Facepiece

Part Number	Description	Packouts Per Case
67P71	Small Respirator Packout	2
68P71	Medium Respirator Packout	2
69P71	Large Respirator Packout	2

### 3M™ Full Facepiece Respirators 7000 Series Ultimate Reusable

This respirator is NIOSH approved for use with all bayonet mount 3M™ Cartridges and/or Filters to help meet OSHA requirements in a variety of marine painting and sanding applications. It features a soft double-flap faceseal made from easy to clean hypo-allergenic silicone. The facepiece has adjustable straps to maximize comfortable fit and protection. It also features a standard nose cup, a speaking diaphragm for clear communication and a scratch-resistant polycarbonate lens. This respirator comes equipped for use with all 3M™ 6000 Series Cartridges and 3M™ 2000 Series Filters.



Part Number	Description	Respirators Per Box	Boxes Per Case
7800S-S	Small Facepiece	1	1
7800S-M	Medium Facepiece	1	1
7800S-L	Large Facepiece	1	1

### 3M™ Chemical Cartridges 6000 Series

Cartridges can be used with 3M™ Half and Full Facepiece Respirators with bayonet attachments.

Part Number	Description	Cartridges Per Package	Packages Per Case
6001	Organic Vapor Cartridge	2	30
6002	Acid Gas Cartridge	2	30
6003	Organic Vapor/Acid Gas Cart.	2	30
6004	Ammonia Methylamine Cart.	2	30
6005	Formaldehyde/Organic Cart.	2	30

### 3M™ Multi-Gas & Vapor Cartridge

This cartridge can be used with 3M™ Half and Full Facepiece Respirators with bayonet attachments. NIOSH approved for organic vapors, chlorine, hydrogen chloride, chlorine dioxide, hydrogen fluoride, sulfur dioxide, hydrogen sulfide (escape only), ammonia, methylamine and formaldehyde.



Part Number	Description	Cartridges Per Package	Packages Per Case
6006	Multi-Gas and Vapor Cartridge	2	30

### 3M™ Combination Cartridge/P100 Particulate Filters 6000 Series

Simplify your need for particulate as well as gas and vapor protection by using these filters. NIOSH approved for solids and aerosols (including oil-based aerosols) for use with 3M™ Half and Full Facepiece Respirators with bayonet attachments. The design is simple, no retainers are required to attach the cartridge to the facepiece. With the different combinations to choose from, these filters are suitable for a variety of applications. The sealed foil package provides a three-year shelf life.



Part Number	Description	Cartridges Per Package	Packages Per Case
60921	Organic Vapor/P100	2	30
60922	Acid Gas/P100 Filter	2	30
60923	Organic Vapor/Acid Gas/P100 Filter	2	30
60924	Ammonia/Methylamine/P100 Filter	2	30
60925	Formaldehyde/Organic Vapor/P100 Filter	2	30
60926	Multi-Gas & Vapor/P100 Filter	2	30
60929	Mercury Vapor & Chlorine Gas/P100 Filter	2	30

### 3M™ Organic Vapor Cartridge/P95 Filter Replacement Packout

This packout contains 1 pair 3M™ Organic Vapor Cartridges 6001 and 2 pairs 3M™ Particulate Filters 5P71, P95. Suggested as replacements for 3M™ Half and Full Facepiece Organic Vapor/P95 Packouts.



Part Number	Description	Cartridges Per Package	Packages Per Case
NEW 051131-07195	Organic Vapor/P95 Replacement Packout	1	5

# 3M™ Respirators

## Replacement Filters for Disposable and Maintainable Respirators

### For use on Chemical Cartridges with 3M™ Retainer 501

#### 3M™ Particulate Filter 5N11, N95

This filter features cake-resistant filter media for easy breathing and lint-resistant coating to help ensure exacting results during painting operations. Can be used with 3M™ Half and Full Facepiece Respirators 5000, 6000 and 7000 Series with bayonet cartridges.



Part Number	Filters Per Box	Boxes Per Case
5N11	10	10

#### 3M™ Particulate Filter 5P71, P95

This filter offers reliable protection against organic vapors and both oil and non-oil particles. 3M™ P95 Prefilters help simplify prefilter selection, inventory and worker training. Prefilters many chemicals and pesticides including oil aerosols. Can be used with 3M™ Half and Full Facepiece Respirators 5000, 6000 and 7000 Series with bayonet style cartridges.



Part Number	Filters Per Box	Boxes Per Case
5P71	10	10

### For use on bayonet style facepieces or with 3M™ Adapter 502

#### 3M™ Particulate Filter 2071, P95

Lightweight and easy to use, this filter is designed for applications such as grinding, sanding and welding. It provides approved protection in environments where oil aerosols may be present. Can be used with 3M™ Half Facepiece Respirators 5000 Series when equipped with the 3M™ Adapter 502 (adapter must be ordered separately.)



Part Number	Filters Per Bag	Bags Per Case
2071	2	50

#### 3M™ Particulate Filter 2076HF, Hydrogen Fluoride, P95, with Nuisance Level Acid Gas Relief

This filter is NIOSH approved for hydrogen fluoride and particles. Also offers relief from nuisance levels (below OSHA PEL) of other acid gases.



Part Number	Filters Per Bag	Bags Per Case
2076HF	2	50

#### 3M™ Particulate Filter 2078, P95, with Nuisance Level Organic Vapor/Acid Gas Relief

This filter is approved for particulate hazards in both oil and non-oil environments. It also offers relief from nuisance levels (below OSHA PEL) of both organic vapors and acid gases. Excellent for dust, welding, metal pouring and certain finishing operations where particles are present with low levels of organic vapor or acid gases.



Part Number	Filters Per Bag	Bags Per Case
2078	2	50

#### 3M™ Particulate Filter 2091, P100

Meets the NIOSH 42 CFR 84 filtration classification, P100. The 2091 does so with 3M's new advanced electret media (AEM). Currently, it is the only filter not made from fiberglass components to achieve a P100 rating. Use for all applications that in the past required the use of dust/mist, dust/fume/mist class or HEPA-rated respiratory protection. The 2091 is: lightweight, versatile, simple to use, compatible, exceptionally efficient respiratory filter, and priced competitively.



Part Number	Filters Per Bag	Bags Per Case
2091	2	50

#### 3M™ Particulate Filter 2096, P100, with Nuisance Level Acid Gas Relief

This filter has been certified as being 99.97% efficient at removing solid and liquid particles including those containing oil. A chemical adsorbent provides relief from nuisance level (below OSHA PEL) odors generated from chlorine, sulfur dioxide and hydrogen fluoride. It features Advanced Electret Media and offers maximum filtration efficiency, simplicity and versatility for both oil and non-oil environments.



Part Number	Filters Per Bag	Bags Per Case
2096	2	50

#### 3M™ Particulate Filter 2097, P100, with Nuisance Level Organic Vapor Relief

This filter has been certified as being 99.97% efficient at removing solid and liquid particles including those containing oil. Used largely for welding, this filter is 3M recommended for ozone protection up to 10X the TLV and welding odor relief (organic vapors below the OSHA PEL).



Part Number	Description	Each Per Bag	Bags Per Case
2097	Filter	2	50
501	Filter Retainer	20	5
502	Filter Adapter	20	5

# 3M™ Respirators

## Replacement Filters for Disposable and Maintainable Respirators

### 3M™ Particulate Filter 7093, P100

This filter has been certified as being 99.97% efficient at removing solid and liquid particles including those containing oil.

- Newly designed for high heat applications.
- Air inlet design creates a channeled airflow that reduces premature clogging.
- Unique, spring loaded filter cover design simplifies user seal check.



	Part Number	Filters Per Carton	Cartons Per Case
NEW	<b>7093</b>	12	5
NEW	<b>7093B (Bulk)</b>	4	36

# 3M™ Respirators

## 3M™ Maintainable Respirator Replacement Parts

### Replacement Parts

	Part Number	Description	Each Per Package	Packages Per Case
<b>For use with 3M Dual Cartridge Respirators</b>				
	<b>501</b>	Filter Retainer	20	5
	<b>502</b>	Filter Adapter	20	5
<b>For use with Half Facepiece Respirators 6000 Series</b>				
	<b>6281</b>	Head Harness Assembly	20	4
	<b>6282</b>	Drop Down Head Harness	20	4
NEW	<b>6889</b>	Exhalation Valve	10	1
NEW	<b>6893</b>	Inhalation Valve	40	5
<b>For use with Full Facepiece Respirators 6000 Series</b>				
	<b>6878</b>	Spectacle Kit	1	1
	<b>6885</b>	Lens Cover	25	4
	<b>6886</b>	Tinted Lens Cover	25	1
	<b>6889</b>	Exhalation Valve	10	1
	<b>6892</b>	Center Adapter Assembly	1	5
	<b>6893</b>	Inhalation Valve	40	5
	<b>6894</b>	Nose Cup Assembly	1	5
	<b>6895</b>	Inhalation Gasket	20	4
	<b>6897</b>	Head Harness Assembly	1	5
	<b>6898</b>	Lens Assembly	1	5
	<b>6899</b>	Frame Kit	1	5
<b>For use with Professional Half Facepiece Respirators 7500 Series</b>				
NEW	<b>7581</b>	Head Harness Assembly	5	4
NEW	<b>7582</b>	Inhalation Valve	10	1
NEW	<b>7583</b>	Exhalation Valve	10	1
NEW	<b>7586</b>	Cartridge Filter Holder	5	4
NEW	<b>051131-37080</b>	Respirator Rebuild Kit	1	5

### Replacement Parts (continued)

	Part Number	Description	Each Per Package	Packages Per Case
<b>For use with Full Facepiece Respirators 7000 Series</b>				
	<b>7282</b>	Inhalation Valve	200	4
	<b>7283</b>	Exhalation Valve	50	5
	<b>7881S</b>	Nose Cup Assembly, Silicone	5	5
	<b>7882</b>	Nose Cup Valve Assembly	20	10
	<b>7883</b>	Neck Strap Assembly	10	10
	<b>7884</b>	Lens	5	5
	<b>7885</b>	Lens Frame Kit	5	5
	<b>7887</b>	Inhalation Valve Gasket	20	10
	<b>7893S</b>	Head Strap Assembly, Silicone	2	2
	<b>7894</b>	Eyeglass Frame and Mount, with Case	1	1
	<b>7895</b>	Speaking Diaphragm Kit	2	2
	<b>7899-100</b>	Lens Cover	100	1
	<b>7899-25</b>	Lens Cover	100	4
	<b>7914</b>	Band Clamp	5	1
	<b>7915-5</b>	Tychem® QC Shroud for 7800S Full Facepiece Respirator (5 pack)	5	1
	<b>7981S</b>	Nose Cup Assembly, Silicone, Small	5	5
	<b>7986</b>	Tinted Lens Cover	25	1
	<b>7989</b>	Full Facepiece Button	54	3
	<b>7993</b>	Welder's Shroud	1	1
	<b>7990</b>	Welder's Faceshield Kit	1	1
	<b>7999</b>	Air Inlet Gasket	10	10
NEW	<b>7991</b>	Electronic Lens Assembly	1	1
NEW	<b>7992</b>	Lens Gasket	1	1

# 3M™ Respirators

## Fresh Air Systems

### 3M™ L-Series Headgear and Accessories

The 3M™ L-Series Headgear Positive Pressure Systems have you covered for just about any job. With several options for headgear, faceshields and other accessories, you can build a complete powered-air or supplied-air system designed specifically for your needs.



To build an air supplied system choose a 3M™ L-Series Headgear, a Breathing Tube, an Air Control Device and an air hose.

A powered air system would include headgear, a breathing tube and an appropriate PAPR and accessories.

The 3M™ L-Series Headgear offers customers options to meet the demands of the work environment with a lightweight and well-balanced design. Available in:

- Bumpcap
- Hardhat (meets ANSI Class I and II hardhat standards)
- Helmet (meets ANSI Class I and II hardhat standards)

Three different faceshield options match workers' needs. The wide-view lens allows for excellent peripheral and downward vision, while virtually eliminating the "closed in" feeling associated with other types of respirators. Lenses include:

- Wide-view lens (available with all headgear options)
- Welding shield (available with bumpcap and hardhat options)
- Wide-view lens and welding shield (available with all headgear options)

A variety of faceseal and shroud options are available.

### 3M™ Air Control Devices V-Series



A complete line of 3M™ Air Control Devices are available for use with the new 3M™ L-Series headgear. Choose between high and low pressure air supply with the capability to heat or cool high-pressure applications where desired. Kits are also available to retrofit your current 3M™ Vortemp™ to work with the 3M™ L-Series headgear.

Comfort is what your employees will enjoy the most about the 3M™ L-Series Headgear. Supplied air systems allow workers to cool or heat the air entering the headgear — ideal for extreme-temperature working conditions. These systems can also be worn with facial hair, prescription eyewear or safety glasses.

Part Number	UPC Number	Description	Packs Per Case
<b>Headgear L-Series</b>			
<b>L-501</b>	051131-37008	Bumpcap with Wide View Faceshield	1
<b>L-503</b>	051138-66148	Bumpcap with Welding Shield	1
<b>L-505</b>	051138-66149	Bumpcap with Welding Shield and Wide View Faceshield	1
<b>L-701</b>	051138-66151	Hardhat with Wide View Faceshield	1
<b>L-703</b>	051138-66152	Hardhat with Welding Shield	1
<b>L-705</b>	051138-66153	Hardhat with Welding Shield and Wide View Faceshield	1
<b>L-901</b>	051138-66155	Helmet with Wide View Faceshield	1
<b>L-905</b>	051138-66156	Helmet with Welding Shield and Wide View Faceshield	1
<b>Accessories L-Series</b>			
<b>L-112-2</b>	051138-66256	Chin Strap (for use with L-Series headgear)	2
<b>L-113-2</b>	051131-37009	Head Suspension (for use with L-Series headgear)	2
<b>L-114-2</b>	051138-66380	Chin Strap, Reinforced (for use with L-Series headgear)	2
<b>L-115-10</b>	051131-37010	Sweat Pad (for use with L-Series headgear)	10
<b>L-116-2</b>	051138-66375	Sweat Pad (for use with L-Series headgear)	2
<b>L-117-2</b>	051138-66376	Hanger Suspension (for use with L-Series headgear)	2
<b>L-120-5</b>	051138-66377	Faceseal, Flame Retardant, Softguard®	5
<b>L-121-5</b>	051131-37011	Faceseal (made of Tyvek® QC fabric)	5
<b>L-122</b>	051131-37012	Breathing Tube (for use with L-Series headgear)	1
<b>L-123-2</b>	051138-66234	Shroud (made of Tyvek® QC fabric)	2
<b>L-124-5</b>	051138-66118	Faceseal, Flame Retardant	5
<b>L-125-2</b>	051138-66119	Shroud, Flame Retardant (made of Nomex®)	2
<b>L-126-2</b>	051138-66120	Inner Shroud	2
<b>L-127</b>	051138-66121	Leather Welding Shroud	1
<b>L-128-2</b>	051138-66122	Shroud (made of Cordura® nylon fabric)	2
<b>L-129-2</b>	051138-66123	Welding Bib, Flame Retardant	2
<b>L-130</b>	051138-66124	Wide-View Faceshield Assembly	1
<b>L-131-10</b>	051131-37013	Wide-View Lens	10
<b>L-132-10</b>	051138-66126	Wide-View Lens, High Temperature	10
<b>L-133-25</b>	051131-37014	Lens Cover	25
<b>L-133-100</b>	051131-37015	Lens Cover	100
<b>L-134-10</b>	051138-66235	Latch Kit	10

Cordura®, Nomex® and Tyvek® are registered trademarks of E. I. du Pont de Nemours and Company.

For more information on selection of fresh air systems see our interactive "Build a System" section on our website at [www.3M.com/occsafety](http://www.3M.com/occsafety)

# 3M™ Respirators

## Fresh Air Systems

### 3M™ L-Series Headgear and Accessories (cont.)

Part Number	UPC Number	Description	Packs Per Case
<b>L-136</b>	051138-66129	Cam Spring Kit	1
<b>L-137</b>	051138-66254	Wide-View Faceshield Extender	1
<b>L-140-10</b>	051138-66130	Knob	10
<b>L-141</b>	051131-37016	Knob and Pivot Kit	1
<b>L-142-2</b>	051138-66132	Welding Gasket (114.3 mm x 133.4 mm) (4.5 in. x 5.25 in.)	2
<b>L-145-10</b>	051138-66135	Welding Knob	10
<b>L-146</b>	051138-66136	Welding Knob and Pivot Kit	1
<b>L-147-2</b>	051138-66137	Welding Lens Retainer Clip	2
<b>L-149-10</b>	051138-66258	Fiber Gasket (114.3 mm x 133.4 mm) (4.5 in. x 5.25 in.)	10
<b>L-150</b>	051138-66138	Welding Shield (for use only with L-503 Bumpcap and L-703 Hardhat; 114.3 mm x 133.4 mm or 4.5 in. x 5.25 in.)	1
<b>L-152-5</b>	051138-66140	Cover Plate (114.3 mm x 133.4 mm) (4.5 in. x 5.25 in.)	5
<b>L-153</b>	051138-66141	Welding Shield (for use only with L-505 Bumpcap, L-705 Hardhat and L-905 Helmet; (114.3 mm x 133.4 mm) (4.5 in. x 5.25 in.)	1
<b>L-156</b>	051138-66144	Electronic Lens and Adapter	1
<b>L-162-2</b>	051138-66259	Safety Plate (114.3 mm x 133.4 mm) (4.5 in. x 5.25 in.)	2
<b>L-163</b>	051138-66145	Foam Liner	1
<b>L-165</b>	051138-66146	Head Seal Kit	1
<b>L-181</b>	051138-72792	Flow Meter Adapter	1
<b>L-182</b>	051138-66379	Air Deflector	1
<b>L-183</b>	051131-37017	Head Gear Cover	1
<b>L-184</b>	051138-66394	High Temperature Welding Shield (114.3 mm x 133.4 mm) (4.5 in. x 5.25 in.)	1

### 3M™ L-Series Headgear and Accessories (cont.)

Part Number	UPC Number	Description	Packs Per Case
<b>L-550</b>	051138-66150	Bumpcap Shell (for use only with the L-500 Series Bumpcaps)	1
<b>L-750</b>	051138-66154	Hardhat Shell (for use only with L-700 Series Hardhats)	1
<b>L-950</b>	051138-66157	Helmet Shell (for use only with the L-900 Series Helmets)	1

### 3M™ Air Control Devices V-Series



Part Number	UPC Number	Description	Packs Per Case
<b>V-100</b>	051131-37018	Vortex Cooling Assembly	1
<b>V-100-SS</b>	051138-66159	Vortex Cooling Assembly, Stainless Steel	1
<b>V-111</b>	051138-66160	Vortex Muffler Kit	1
<b>V-115</b>	051138-66161	Vortex Spare Parts Kit	1
<b>V-117</b>	051138-66162	Vortex Conversion Kit	1
<b>V-150</b>	051138-66164	Vortex Cooling Tube	1
<b>V-150-SS</b>	051138-66165	Vortex Cooling Tube, Stainless Steel	1
<b>V-200</b>	051138-66166	Vortemp™ Heating Assembly	1
<b>V-200-SS</b>	051138-66167	Vortemp™ Heating Assembly, Stainless Steel	1
<b>V-211</b>	051138-66168	Vortemp™ Muffler Kit	1
<b>V-215</b>	051138-66169	Vortemp™ Spare Parts Kit	1
<b>V-250</b>	051138-66171	Vortemp™ Heating Tube	1
<b>V-250-SS</b>	051138-66172	Vortemp™ Heating Tube, Stainless Steel	1
<b>V-300</b>	051131-37019	Air Regulating Valve Assembly	1
<b>V-300-SS</b>	051138-66174	Air Regulating Valve Assembly, Stainless Steel	1
<b>V-350</b>	051138-66176	Air Regulating Valve	1
<b>V-350-SS</b>	051138-66177	Air Regulating Valve, Stainless Steel	1
<b>V-400</b>	051131-37020	Low Pressure Connector Assembly	1

# 3M™ Respirators

## Fresh Air Systems

### 3M™ H-Series Positive Pressure Hoods

The NIOSH approved 3M™ H-Series Positive Pressure Hoods offer superior comfort in the most demanding work environments. Lightweight and loose fitting with a unique airflow design that helps prevent fogging of the wide-view faceshield. 3M™ H-Series hoods provide comfort while protecting the worker from outside contaminants. Optional air control devices allow the incoming air to be heated or cooled by as much as 50°F.



### 3M™ H-Series Hoods and Head Covers

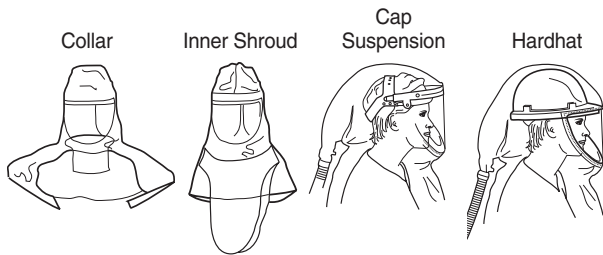

These 3M™ H-Series Hoods and Head Covers offer superior comfort in the most challenging environments. They are lightweight and loose fitting. 3M™ H-Series Hoods offer higher protection factors than negative pressure respirators and eliminate the need for fit testing. These hoods and head covers are effective for paint or gelcoat spraying, sanding or general maintenance.

Part Number	UPC Number	Description	Packs Per Case
<b>H-411</b>	051138-66096	Hood Assembly with Collar and Cap Suspension, Tychem® QC	1
<b>H-412</b>	051138-66097	Hood Assembly with Collar and Hardhat, Tychem® QC	1
<b>H-421</b>	051138-66099	Hood Assembly with Inner Shroud and Cap Suspension, Tychem® QC	1
<b>H-422</b>	051138-66100	Hood Assembly with Inner Shroud and Hardhat, Tychem® QC	1

Tychem® is a registered trademark of E. I. du Pont de Nemours and Company.

### 3M™ H-Series Sealed-Seam Positive Pressure Hoods (cont.)

Part Number	UPC Number	Description	Packs Per Case
<b>H-610-5</b>	051138-76550	Sealed-Seam Hood, Tychem® SL with Collar	5
<b>H-611</b>	051138-76551	Sealed-Seam Hood Assembly, with Collar and Cap Suspension, Tychem® SL. Includes 2 hoods H620, cap suspension H113, chin strap H114, 2 faceshield covers H110 and squeeze clamp W3222	1
<b>H-612</b>	051138-76552	Sealed-Seam Hood Assembly, with Collar and Cap Suspension, Tychem® SL. Includes 2 hoods H620, cap suspension H113, chin strap H114, 2 faceshield covers H110 and squeeze clamp W3222	1

Tychem® is a registered trademark of E. I. du Pont de Nemours and Company.

### 3M™ H-Series Hood Accessories

Part Number	UPC Number	Description	Packs Per Case
<b>H-110-10</b>	051138-66086	Faceshield Cover	10
<b>H-111-100</b>	051138-66087	Faceshield Cover	100
<b>H-113-2</b>	051138-66089	Cap Suspension	2
<b>H-114-2</b>	051138-66090	Chin Strap	2
<b>W-2870-5</b>	051138-16235	Sweatband	5
<b>W-2879</b>	051138-29164	Ratchet Suspension	1
<b>W-3222-2</b>	051138-19346	Squeeze Clamp	2
<b>W-3261</b>	051138-29193	Ratchet Kit	1
<b>W-3262-10</b>	051138-29136	Nape Pad	10

### 3M™ H-Series Hood Replacement Parts

Part Number	UPC Number	Description	Packs Per Case
<b>GVP-122</b>	051138-29214	Breathing Tube (for use with GVP PAPR System)	1
<b>H-115</b>	051138-66181	Breathing Tube Assembly (includes H116, W5102, W3222)	1
<b>H-116-2</b>	051138-66182	Replacement Breathing Tube	2
<b>H-410-10</b>	051131-07037	Hood with Collar Tychem® QC	10
<b>H-420-10</b>	051138-66098	Hood with Inner Shroud	10
<b>W-2871-5</b>	051138-28891	Crown Strap Assembly for W2878 and W2879	5
<b>W-2878-2</b>	051138-17554	Head Suspension	2
<b>W-3258-5</b>	051131-07039	Snapcap Hardhat	5
<b>W-5102-2</b>	051138-15319	Thumbscrew Clamp	2
<b>W-5114</b>	051138-15324	Breathing Tube (Supplied Air Only)	1

Tychem® is a registered trademark of E. I. du Pont de Nemours and Company.



# 3M™ Respirators

## 3M™ Belt-Mounted Powered Air Purifying Respirators (PAPR's)

The 3M™ Belt-Mounted Powered Air Purifying Respirator (PAPR) combines a high level of protection with great performance and versatility. This innovative design is able to operate with the 3M™ H-Series Hoods, L-Series Headgear and the Full Facepieces 7800S and 6000 Series.



### The GVP1 PAPR Assembly includes:

- GVP-100 Motor Blower
- GVP-110 Power Cord
- GVP-111 Battery Pack
- GVP-112 Battery Charger
- GVP-128 Web Shoulder Strap
- GVP-115 Blower Plugs
- GVP-116 Filter Plugs
- GVP-127 Web Belt
- GVP-113 Flow Meter

## 3M™ Belt Mounted Powered Air Purifying Respirators, with Comfort Belt

Includes: all components from GVP-1 assembly with the exception of the GVP-127 web belt and GVP-128 web shoulder strap. Each assembly includes one comfort belt CB-1000.

Part Number	UPC Number	Description	Each Per Case
<b>GVP-CB</b>		Comfort Belt-Mounted PAPR Assembly (one size fits most persons)	1 Pack
<b>GVP-PSK/07190</b>		PAPR Paint Spray Kit	

The 3M™ GVP PAPR Kit GVP-PSK/07190 includes all of the components that make up our PAPR with Bumpcap and is now available as a single part number in a single package. It includes the following which make a complete PAPR system:



- 1 - Bumpcap with Wide View Faceshield L-501
- 1 - Breathing Tube L-122
- 1 - Comfort Belt-Mounted PAPR Assembly
  - Motor Blower GVP-100
  - Battery GVP-111
  - Charger GVP-112
  - Flow Meter GVP-113
  - Power Cord GVP-110
  - Blower Plugs GVP-115
  - Flow Meter Adapter L-181
  - Comfort Belt CB-1000
- 1 - Organic Vapor/HEPA Cartridge GVP-441
- 1 - Shower Cover GVP-119
- 5 - Peel-Off Lens Covers for L-501 Bumpcap

## 3M™ Belt Mounted Powered Air Purifying Respirators, with Comfort Belt (continued)

Part Number	UPC Number	Description	Each Per Case
<b>GVP-100</b>	051138-29206	Motor Blower Unit	1
<b>GVP-101</b>	051138-29281	Motor Blower Gaskets	5 Inlet, 5 Outlet
<b>GVP-110</b>	051138-29207	Power Cord	1
<b>GVP-111</b>	051138-29208	Battery Pack	1
<b>GVP-112</b>	051138-29209	Battery Charger	1
<b>GVP-113</b>	051138-29210	Flow Meter	1
<b>GVP-114</b>	051138-29211	Flow Cover	10
<b>GVP-115</b>	051138-29212	Blower Plugs	5 Motor Blower, 5 Air Outlet
<b>GVP-116</b>	051138-29213	Filter Plugs	10
<b>GVP-117</b>	051138-29223	Urethane Waist Belt	1
<b>GVP-118</b>	051138-29224	Urethane Shoulder Strap	1
<b>GVP-119</b>	051138-54304	Shoulder Cover	5
<b>GVP-122</b>	051138-29214	Breathing Tube (for GVP-1 with Snapcap Hoods)	1
<b>GVP-123</b>	051138-29215	Breathing Tube (for GVP-1 with 7800S Full Facepiece)	1
<b>GVP-127</b>	051138-29268	Web Belt	1
<b>GVP-128</b>	051138-29267	Web Shoulder Strap	1
<b>CB-1000</b>	051131-52772	Comfort Belt	1
<b>Cartridges and Filters</b>			
<b>GVP-401</b>	051138-29216	Organic Vapor Cartridge	6
<b>GVP-402</b>	051138-29217	Acid Gas Cartridge	6
<b>GVP-403</b>	051138-29218	Organic Vapor/Acid Gas Cartridge	6
<b>GVP-440</b>	051138-29219	HEPA Filter	8
<b>GVP-441</b>	051138-29220	Organic Vapor/HEPA Cartridge	6
<b>GVP-442</b>	051138-29221	Acid Gas/HEPA Cartridge	6
<b>GVP-443</b>	051138-29222	Organic Vapor/Acid Gas/HEPA Cartridge	6

# 3M™ Respirators

## Fresh Air Systems

### System Accessories — H-Series Hoods



Part Number	Description	Each Per Case
<b>High Pressure System (60-100 psi Supply Pressures)</b>		
W-5114	Breathing Tube	1
W-2862	Vortex Air Cooling Assembly	1
W-2907	High Pressure Adapter Assembly	1
W-9435-25	Compressed Air Hose 25', 3/8" ID	1
W-9435-50	Compressed Air Hose 50', 3/8" ID	1
W-9435-100	Compressed Air Hose 100', 3/8" ID	1
<b>Low Pressure System (4-15 psi Supply Pressures)</b>		
W-5114	Breathing Tube	1
W-3018	Low Pressure Adapter Assembly	1
W-3020-25	Low Pressure Hose 25', 1/2" ID	1
W-3020-50	Low Pressure Hose 50', 1/2" ID	1
W-3020-100	Low Pressure Hose 100', 1/2" ID	1

### 3M™ Fresh Air Filter and Regulating Panels for use with L-Series Headgear and H-Series Hoods



W-2806



W-2808

Part Number	Description	Each Per Case
<b>Replacement Parts and Accessories</b>		
W-2806	High Pressure Compressed Air Filter and Regulator Panel	1
<b>NEW</b> W-2808	CO Monitor with Retro Fit Kit	1
<b>Accessories for the W-2806</b>		
W-2811-10	Replacement Filter Cartridge (10 pack)	1
W-2915	Filter Bowl	1
W-2921	Bowl Gasket	1
W-2923	Cartridge Washer	1
W-3046	Bowl Guard	1
W-3096	Air Pressure Regulator	1
W-3099	Air Pressure Gauge	1
W-3012	Coalescing Filter Assembly	1
W-3013-4	Replacement Coalescing Filter (4 pack)	1

### 3M™ Portable Air Purification Panel 256-02-00, with Co Filtration and Monitor, 50 CFM, 4 Outlets



### 3M™ Portable Air Purification Panel 256-02-01, with Co Monitor, 100 CFM, 8 Outlets

Part Number	Description
<b>Accessories for the 256-02-XX</b>	
523-01-28	Replacement Filter Kit, 50 cfm
523-01-29	Replacement Filter Kit, 100 cfm
529-04-49	Calibration Kit (for CO monitor)
529-04-48	Calibration Kit, Large (for CO monitor)
529-04-50	110-120 AC Adapter (for CO monitor)
529-05-18	Zero Gas Cylinder
529-05-19	Span Gas Cylinder
529-05-17	Zero Gas Cylinder
529-05-16	Span Gas Cylinder, Large
529-05-20	Remote External Alarm or Remote Alarm, Audible
529-05-21	Remote External Strobe or Remote Alarm, Strobe
529-05-23	Y-Plug Adapter
529-05-22	Replacement Sensor for CO

### OSHA regulations

The Occupational Safety and Health Administration (OSHA) state in 29 CFR 1910.134 (i) that air quality for breathing air shall meet at least the requirements of the specification for Grade D breathing air as described in Compressed Gas Association Commodity Specification ANSI/CGA G-7.1 1989, in the United States, and Table 2 of the CSA standard CAN3-Z180.1-M85, in Canada. Grade D breathing air consists of:

Oxygen.....	19.5 to 23.5%
Hydrocarbons.....	<5mg/m3 (oil condensed)
Carbon Monoxide .....	<10ppm
Odor.....	no noticeable odor
Carbon Dioxide .....	<1000ppm

The 3M Air Purification Panels can aid in providing Grade D breathing air. Air samples should be tested regularly to determine that Grade D air is being supplied.

# 3M™ Respirators

## 3M™ Dual Airline Supplied Air Respirators

**Ordering Information.** Selection of a complete 3M™ Dual Airline System is as easy as 1, 2 and 3. (e.g. 7800S-M + SA-2000 + W-9435-100 = complete system.) For a combination system, also choose an appropriate NIOSH 42 CFR 84 approved cartridge/filter from pages 152-154.

### Step 1. Select a 3M™ Facepiece.



#### 7800S Series Full Facepiece

- 7800S-SM Small
- 7800S-M Medium
- 7800S-L Large



#### 6000 Series Half Facepiece

- 6100 Small
- 6200 Medium
- 6300 Large



#### 7500 Series Half Facepiece

- 7501 Small
- 7502 Medium
- 7503 Large



#### 6000 Series Full Facepiece

- 6700 Small
- 6800 Medium
- 6900 Large

### Step 2. Select a 3M™ Adapter Kit.



- SA-1000 or SA-1000LP (low pressure) Adapter Kit. Includes SA-1500 Breathing Tube, GVP-127 Web Belt, and SA-1009 Air Regulator or SA-1029 Connector (low pressure).

- Combination Dual Airline
- SA-1100 or SA-1100LP (low pressure) Adapter Kit. Includes SA-1600 Combination Breathing Tube, GVP-127 Web Belt and SA-1009 Air Regulator or SA-1029 Connector (low pressure). Cartridges/filters not included.



- SA-2000 or SA-2000LP (low pressure) Adapter Kit. Includes SA-2500 Back-Mounted Breathing Tube, GVP-127 Web Belt, and SA-1009 Air Respirator or SA-1029 Connector (low pressure).

- Combination Dual Airline
- SA-2100 or SA-2100LP (low pressure) Adapter Kit. Includes SA-2600 Combination Back-Mounted Breathing Tube, GVP-127 Web Belt, and SA-1009 Air Regulator or SA-1029 Connector (low pressure). Cartridges/filters not included.

### Step 3. Select a 3M™ Air Supply Hose\*.

	25'	50'	100'
W-9435 High Pressure Hose, 3/8" ID**	<input type="checkbox"/>	<input type="checkbox"/>	<input type="checkbox"/>
W-2929 Coiled High Pressure Hose, 3/8" ID**	<input type="checkbox"/>	<input type="checkbox"/>	<input type="checkbox"/>
W-3020 Low Pressure Hose, 1/2" ID	<input type="checkbox"/>	<input type="checkbox"/>	<input type="checkbox"/>

\* Specify type and length.

\*\* Also available with stainless steel fittings. (When ordering, add SS to product number, e.g., W-9435SS-100)

### Pressure Requirements

Hose Length		SA-1009 Regulator, W-9435 or W-2929 Hose (psi)	SA-1029 Connector, W-3020 Hose (psi)
Feet	Meters		
25	7.62	16 - 24	8 - 16
50	15.24	17 - 26	9 - 16
100	30.48	18 - 27	10 - 17
200	60.96	21 - 33	NA
300	91.44	25 - 38	NA

**IMPORTANT:** For use up to 1000 x PEL as full facepiece supplied air and 50 x PEL as half facepiece supplied air, or applicable OSHA and other government limits, whichever is lower.

### 3M™ Replacement Parts

SA-2500 Back-Mounted Breathing Tube*	SA-1007 Air Regulator Assembly.* Includes SA-1009 Air Regulator and GVP-127 Web Belt	GVP-127 Web Belt
SA-2600 Combination Back-Mounted Breathing Tube	SA-1009 Air Regulator*	SA-1115 Breathing Tube Clips (5/bag)
SA-1500 Front-Mounted Breathing Tube*	SA-1027 Low Pressure Connector Assembly. Includes SA-1029 Connector and GVP-127 Web Belt	W-2806 Filter and Regulator Panel
SA-1600 Combination Breathing Tube	SA-1029 Air Connector (low pressure)	6880 Bayonet Cap (10/bag)

\* Also available with stainless steel fittings. (When ordering add SS to product number, e.g., SA-2500SS.)

# 3M™ Respirators

## 3M™ Airline Continuous Flow Respirator Adapter Kits

These adapter kits include all components necessary to modify the 3M™ 7800S Full Facepiece to positive pressure airline mode. When used in this manner, this respirator is limited to use in concentrations of contaminants below the immediately dangerous to life or health (IDLH) values, or specific OSHA standards, whichever is less. The unique design of the NIOSH approved 7800S enables the wearer to operate either with cartridges and prefilters or low-pressure air pumps or high-pressure compressed air in one respirator assembly. Eliminates the need to purchase separate systems for painting, grinding and sanding applications.



## High Pressure System (15 to 70 psi Supply Pressures)

High Pressure System Kit contains: W-3060 Airline Adapter Kit includes: one W-3061 Air Regulator Valve (ARV) Assembly and one W-9435 High Pressure Hose. (W-3061 ARV includes one each of: W-3062 Air Regulating Valve, W-3187 Adapter Assembly, W-3188 Breathing Tube, W-3217 Waist Belt, W-3229 Shoulder Strap and 7890 Facepiece Port Plug).

Part Number	Description	Kits Per Case
<b>W-3060-25</b>	High Pressure Airline Adapter Kit with 25' Air Hose	1
<b>W-3060-50</b>	High Pressure Airline Adapter Kit with 50' Air Hose	1
<b>W-3060-100</b>	High Pressure Airline Adapter Kit with 100' Air Hose	1

## Low Pressure System (8 to 36 psi Supply Pressures)

Low Pressure System Kit contains: W-3196 Air Regulating Kit includes one each of: W-3187 Adapter Assembly; W-3188 Breathing Tube; W-3194 Low Pressure Connector; W-3217 Waist Belt; W-3229 Shoulder Strap and 7890 Facepiece Port Plug. W-9435 Compressed Air Hose is not included in the kit and must be purchased separately.

Part Number	Description	Each Per Case
<b>W-3196</b>	Low Pressure Air Regulating Kit	1
<b>W-9435-25</b>	Compressed Air Hose with 25', 3/8" ID	1
<b>W-9435-50</b>	Compressed Air Hose with 50', 3/8" ID	1
<b>W-9435-100</b>	Compressed Air Hose with 100', 3/8" ID	1

## Low Pressure System (7 to 18 psi Supply Pressures)

Low Pressure System Kit Contains: W-3197 Air Regulating Kit includes one each of: W-3187 Adapter Assembly; W-3188 Breathing Tube; W-3195 Low Pressure Connector; W-3217 Waist Belt; W-3229 Shoulder Strap and 7890 Facepiece Port Plug. W-3020 Low Pressure Hose is not included in the kit and must be purchased separately.

Part Number	Description	Each Per Case
<b>W-3197</b>	Low Pressure Air Regulating Kit	1
<b>W-3020-25</b>	Low Pressure Hose 25', 1/2" ID	1
<b>W-3020-50</b>	Low Pressure Hose 50', 1/2" ID	1
<b>W-3020-100</b>	Low Pressure Hose 100', 1/2" ID	1

## 3M™ Airline Continuous Flow Respirator Adapter Kits (cont.)

### Replacement Parts and Accessories

Part Number	Description	Each Per Case
<b>W-3062</b>	Air Regulating Valve	1
<b>W-3187</b>	Adapter Assembly	1
<b>W-3188</b>	Breathing Tube	1
<b>W-3194</b>	Low Pressure Connector for use with W-9435 3/8" Hose	1
<b>W-3195</b>	Low Pressure Connector for use with W-3020 1/2" Hose	1
<b>W-3217</b>	Vinyl Waist Belt	1
<b>W-3229</b>	Vinyl Shoulder Strap	1
<b>7890</b>	Facepiece Port Plug	20

## 3M™ Face-mounted Powered Air Purifying Respirator

The 3M™ Face-mounted Powered Air Purifying Respirator (PAPR) is a NIOSH approved, powered air purifying full facepiece designed for respiratory protection against certain dusts, fumes and mists having a time weighted average less than 0.05 mg/m<sup>3</sup>, found in most grinding and sanding marine applications as well as asbestos-containing dusts and mists. It features a lightweight motor blower which produces airflow greater than 6.2 cfm in the respirator. This allows greater comfort and easier breathing and facial cooling. The blower is powered by a compact, rechargeable battery pack which conveniently hooks onto the workers belt during use.



System contains: 3M™ Silicone Full Facepiece; 3M™ W-3266 Motor Blower; 3M™ W-3267 HEPA Filter; 3M™ W-3269 Flow Meter; 3M™ W-3271 Filter Cover; 3M™ W-2933 Charger; 3M™ W-2954 Battery; 3M™ W-3217 Vinyl Belt; 3M™ 7890 Plugs (2).

Part Number	Description	Each Per Case
<b>W-3265-SL</b>	Face-mounted PAPR System (Large)	1
<b>W-3265-SM</b>	Face-mounted PAPR System (Medium)	1

### Replacement Parts and Accessories

<b>W-2933</b>	Battery Charger	1
<b>W-2954</b>	Battery Pack	1
<b>W-3217</b>	Vinyl Waist Belt	1
<b>W-3266</b>	Motor Blower/Power Cord Unit	1
<b>W-3267</b>	HEPA Filter	36
<b>W-3268-5</b>	Exhalation Valve Cover	1
<b>W-3269</b>	Flow Meter	1
<b>W-3270-10</b>	Filter Gasket	10
<b>W-3271-5</b>	Filter Cover	5
<b>7890</b>	Facepiece Port Plug	20

# 3M™ Respirators

## Self Contained Breathing Apparatus (SCBA)

When the highest level of respiratory protection is required, turn to 3M's family of Self Contained Breathing Apparatus (SCBA). The 3M line features a variety of harness and cylinder options to meet most any IDLH need. 3M's SCBA line also features the versatile, 7800S-AM Full Facepiece, which can streamline annual fit testing efforts required under OSHA 29 CFR 1910.134.



### 3M™ Air-Mate™ 2000 Self-Contained Breathing Apparatus

Provides respiratory protection for workers who must perform duties in IDLH conditions. The 30-minute 2000 SCBA is NIOSH approved for entry and escape. The worker can stay in the area until the low pressure alarm sounds or until conditions dictate leaving the area.



### 3M™ Air-Mate™ SCBAG™ Self-Contained Breathing Apparatus

Unlike any other product in its class, the 30-minute SCBAG™ is stored in a unique carrying bag that opens to form a vest with the SCBA system in place and ready for use. The SCBAG has unmatched portability and can be donned in a matter of seconds.



### 3M™ Air-Mate™ Combination ESCBA/SAR

Offers the flexibility of 5- and 15-minute combination escape\* SCBA/supplied air respirators. It offers a high level of respiratory protection for applications such as petrochemical, nuclear, hazardous materials handling, waste treatment, confined areas or other IDLH conditions.

\*When using the 15-minute rated service life cylinder equipped with a remote alarm and pressure gauge, entry into an IDLH atmosphere (and subsequent connection to a supplied airline) may be on the cylinder as long as no more than 20% of the air is used for entry.

For more information on the complete line of 3M SCBA Products please contact your 3M Marine Representative at 1-877-3M MARINE (1-877-366-2746)

<b>WARNING</b>	
	<p><b>Self-Contained Breathing Apparatus Respirators</b></p> <p>These respirators help protect against certain contaminants and may be used in oxygen deficient and Immediately Dangerous to Life and Health (IDLH) environments. <b>Misuse may result in serious bodily injury, sickness and death.</b> For proper use, see your supervisor, the User Instructions or call 3M OH&amp;ESD Technical Service Department at 1-800-243-4630. In Canada, call 1-800-267-4414. In Mexico, call 1-800-712-4606. In Brazil, call 0800-550705.</p>

# 3M™ Respirators

## 3M™ Fit Test Apparatus and Accessories

### OSHA's Respirator Program Requirements\*

In any workplace where respirators are necessary to protect the health of the employee or whatever respirators are required by the employer, the employer shall establish and implement a written respiratory protection program with worksite-specific procedures. The program shall be updated as necessary to reflect those changes in workplace conditions that affect respirator use. The employer shall include in the program the following provisions of OSHA standard 1910.134:

1. Procedures for selecting respirators for use in the workplace;
2. Medical evaluations of employees required to use respirators;
3. Fit testing procedures for tight-fitting respirators;
4. Procedures for proper use of respirators in routine and reasonably foreseeable emergency situations;
5. Procedures and schedules for cleaning, disinfecting, storing, inspecting, repairing, discarding, and otherwise maintaining respirators;
6. Procedures to ensure adequate air quality, quantity, and flow of breathing air for atmosphere-supplying respirators;
7. Training of employees in the respiratory hazards to which they are potentially exposed during routine and emergency situations;
8. Training of employees in the proper use of respirators, including putting them on and removing them, any limitations on their use, and a maintenance; and
9. Procedures for regular evaluating the effectiveness of the program.

The employer shall designate a program administrator who is qualified by appropriate training or experience that is commensurate with the complexity of the program to administer or oversee the respiratory protection program and conduct the required evaluations of program effectiveness.

\* 29 CFR Part 1910, 134(b). Requirements of a minimal respirator program.

No matter how effectively a respirator is designed, it offers you little or no protection if not worn properly. That's why 3M's training program and Fit Test Apparatus will inform you of the correct way to wear a 3M™ respirator and confirm that it fits properly. To assist in training and fitting employees working in the marine environment, the FT-10/FT-20 3M™ Training and Fit Testing Kits include all that is needed for a complete respiratory fitting program.



Part Number	Description	Each Per Box	Boxes Per Case
FT-10	Fit Test Apparatus Kit	1	1
FT-11	Sensitivity Solution	1	6
FT-12	Fit Test Solution	1	6
FT-13	Nebulizer	1	3
FT-14	Test Hood (2/Pack)	2	5
FT-15	Collar	1	1
FT-20	3M™ Training & Fit Testing Case	1	1
FT-30	Qualitative Fit Test Apparatus, Bitter	1	1
FT-31	Sensitivity Solution, Bitter	1	6
FT-32	Fit Test Solution, Bitter	1	6

### 3M™ Respirator Compliance Software – Windows® Based CD-ROM Required

3M™ Respirator Compliance Software:

- Developed to help customer comply with the OSHA requirements.
- Provided forms for employee and workplace records.
- Completely menu driven, no computer experience is needed.
- Provides audit trail.
- Alerts you to the need for training, fit testing, etc.
- Computer needs: Minimum 486 IMB PC or fully compatible with CD-ROM drives. VGA graphics or compatible adapter and 15 MB available on hard drive for each program.
- Operating System: Windows® 3.1, Windows® 95, Windows® NT, or Windows® for Workgroups.
- Memory: 16 MB RAM memory and a minimum of an additional 16 MB virtual memory.

Part Number	Description	Each Per Case
RCSCD	Respirator Compliance Software	1

Windows® is a registered trademark of Microsoft Corporation.

### 3M™ Air Monitoring Systems

When sampling of working environment air is needed for respiratory analysis, 3M™ Air Monitoring Systems offer the easiest to use and most cost-effective personal air monitoring system. Designed for monitoring specific contaminants, the monitor simply is clipped to the workers clothing and worn for a specified time period. It can then be sent to 3M for analysis or 3M will provide complete analytical procedures for in-house analysis.



Part Number	Description	Each Per Box	Boxes Per Case
3500	Organic Vapor Monitor (Monitor Only)	1	10
3510	Organic Vapor Monitor (Prepaid Analysis System)	1	5
3720	Formaldehyde Monitor (Prepaid Analysis System)	1	5

### 3M™ Respirator Cleaning Wipes

These individually wrapped 3M™ Respirator Cleaning Wipes are designed especially for use with the 3M™ 5000 Series, 6000 Series and 7000 Series Half and Full Facepiece Respirators. The alcohol-free formula cleans the facepieces without any negative effect upon facepiece materials. Conveniently packaged in a dispenser style box that can be wall mounted for easy access.



Part Number	Description	Each Per Box	Boxes Per Case
504	Respirator Cleaning Wipes	100	5

### 3M Hearing Compliance Software helps you develop and manage your hearing conservation programs

Part Number	Description	Each Per Box
HCSCD	Hearing Compliance Software	1
SSCD	Select Software	1

3M™ Select Software® helps you select the most appropriate respirator for the job.

# 3M™ Hearing Protection Products

## 3M™ Foam Ear Plugs

Use to protect hearing from loud and constant noises generated by grinding, sanding, buffing, engine work and other marine operations.

## 3M™ Soft Foam Ear Plugs 1120 and 1130

New softer formulation for improved comfort. Patented articulated shape for improved fit. Low pressure inside the ear canal for improved comfort. NRR 29 dB. Can be combined with ear muffs for added protection.



	Part Number	Description	Pairs Per Box	Boxes Per Case
NEW	1120	Ear Plug	200	5
NEW	1130	Corded Ear Plug	100	5

## 3M™ Disposable Foam Ear Plugs 1100 and 1110

These plugs provide comfortable and effective noise reduction (Noise Reduction Rating (NRR) is 29dB) with the convenience of disposability. Available as individual ear plugs or with a cord attached that provides accessibility and helps prevent loss.



	Part Number	Description	Pairs Per Box	Boxes Per Case
	1100	Ear Plug	200	5
	1110	Corded Ear Plug	100	5

## 3M™ Reusable Ear Plugs

3M™ Reusable Ear Plugs offer comfortable and reliable hearing protection with a Noise Reduction Rating (NRR) of 25dB. With a triple flanged design, they fit securely in the ear canal, providing a comfortable fit. 3M plugs do not have to be "rolled down" to achieve proper fit. This provides greater hygiene, as the workers hands need not touch the portion of the ear plug being inserted into the worker's ear. Available as individual ear plugs or with a cord attached that provides accessibility and helps prevent loss. Available with a convenient storage and carrying case.

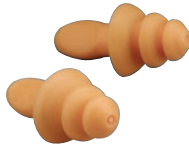

Part Number	Description	UPC Number	Pairs Per Box	Boxes Per Case
1260	Reusable	051138-66226	100	5
1270	Reusable, corded	051138-66228	100	5
1271	Reusable, corded with carry case	051138-66229	50	5

## 3M™ Banded Hearing Protector

The 3M™ Banded Hearing Protector has a unique flexible band design that allows greater ease of use and low pressure over a wide range of head sizes for superior comfort and effective noise reduction (Noise Reduction Rating (NRR) is 21 dB worn behind the head and 20 dB worn under the chin). The 3M™ Banded Hearing Protector is designed to reduce contact with clothing and skin lessening noise transmission. Round foam tips do not enter the ear and allow for potentially better hygiene. The 3M™ Banded Hearing Protector is compatible with other safety products.



Part Number	UPC Number	Each Per Box	Boxes Per Case
1310	051138-66003	10	5

Part Number	UPC Number	Pairs Per Box	Boxes Per Case
<b>Replacement Pads*</b>			
1311	051138-66004	20	5

\* For use with 1310 Banded Hearing Protectors

## 3M™ General Purpose Ear Muff 1435

This 3M™ Ear Muff is safety orange in color. It has a forked adjustable headband for fit and comfort. The molded noise suppression inserts and ear cushions are replaceable. Noise reduction of 23dB.



Part Number	UPC Number	Pairs Per Case
1435	051138-29333	20

## 3M™ Replacement Parts Kit for 3M™ 1435 Ear Muffs

This kit consists of one pair noise suppression inserts and one pair ear cushions.



Part Number	UPC Number	Pairs Per Case
1437	051138-29341	10

# 3M™ Hearing Protection Products

## 3M™ Padded Ear Muff 1440

This 3M™ Ear Muff has a padded and adjustable headband for added comfort and proper fit. Anatomically designed ear cushion for fit. The molded noise suppression inserts and ear cushions are replaceable. Noise reduction of 24dB.



Part Number	UPC Number	Pairs Per Case
1440	051138-29334	20

## 3M™ Low Profile Ear Muffs 1425

This 3M™ Low Profile Ear Muff has soft, foam filled cushions, adjustable swivel cups and a sliding headband to fit a wide range of head sizes. Lightweight. NRR 22 dB.



Part Number	UPC Number	Pairs Per Case
1425	051138-76939	20

## 3M™ Replacement Parts Kit for 3M™ 1440 and 1450 Ear Muffs

This kit consists of one pair noise suppression inserts and one pair ear cushions.



Part Number	UPC Number	Pairs Per Case
1442	051138-29342	10

## 3M™ Three-Position Ear Muff 1427

This 3M™ Three-Position Ear Muff has three different headband positions and an adjustable head strap to secure the muff when worn positioned under the chin or behind the head. NRR 27 dB when worn over and behind the head and 26 dB when worn under the chin.



Part Number	UPC Number	Pairs Per Case
1427	051138-76981	20

## 3M™ Hard Hat Mounted Ear Muff 1450

This 3M™ Hard Hat Mounted Ear Muff fits a variety of hard hats including 3M, MSA, Willson and Bullard. No adapters are required. Noise reduction of 23dB.



Part Number	UPC Number	Pairs Per Case
1450	051138-29335	20



# 3M™ Head, Eye and Face Protection

## 3M™ Head and Face Protection Products

Head and Face Protection Products are designed to enhance safety in the work place. In addition, they combine personal comfort, and a fashionable appearance with overall value. All 3M™ Head Protection Products feature lightweight high-density polyethylene molding, fully cushioned brow pads for moisture absorption, a 6 point suspension, and compliance with ANSI Z89.1-1997 Type 1, Class C, E, and G requirements. Omega II hard hats – standard slide suspension adjusts to fit sizes 6-1/2 to 7-1/4. Ratchet suspension fits 5-1/8 to 8. Ratchet has soft removable head band for maximum adjustability and comfort. Key advantages are: meets ANSI requirements, available in variety of colors, styles and suspensions, can be worn backwards by adjusting suspension, front brimmed or full brim styles available.

## 3M™ Visitor Specs 1611/37101, Clear

3M™ Visitor Specs provide eye protection for temporary visitors, and short term users. Can be worn alone or over prescription glasses.



Part Number	Description	Each Per Pack	Packs Per Case
051131-37101	1611 Visitor Specs, Clear	1	300

## 3M™ Safety Goggles 1620/37102, Perforated

3M™ Safety Goggles are perforated, soft and comfortable with flexible vinyl frames. These are goggles for general use and should not be worn in areas where chemical splashes and fumes may be present.



Part Number	Description	Each Per Pack	Packs Per Case
051131-37102	1620 Safety Goggles, Perforated	1	288

Part Number	Description	Each Per Case
051131-37100	3M™ 1801 Bump Cap, Black	6
051131-52589	3M™ 1803 Bump Cap, White	6
051138-37106	3M™ 1631 Faceshield Kit	5
051138-37107	3M™ 1632 Replacement Visor (for 3M™ Faceshield Kit)	10
051138-76808	Replacement Suspension (for 3M™ Bump Cap)	10
051138-76809	3M™ 1901 Omega II™ Hard Hat, White, Standard Suspension	30
051138-76810	3M™ 1902 Omega II™ Hard Hat, Yellow, Standard Suspension	30
051138-76811	3M™ 1903 Omega II™ Hard Hat, Orange, Standard Suspension	30
051131-52590	3M™ 1905 Omega II™ Hard Hat, Red, Standard Suspension	30
051131-52591	3M™ 1906 Omega II™ Hard Hat, Blue, Standard Suspension	30
051138-76812	3M™ 1904 Replacement Standard Suspension (for 3M™ Omega II™ Hard Hat)	10
051138-76813	3M™ 1911 Omega II™ Hard Hat, White, Ratchet Suspension	30
051138-76814	3M™ 1912 Omega II™ Hard Hat, Yellow, Ratchet Suspension	30
051131-52592	3M™ 1915 Omega II™ Hard Hat, Red, Ratchet Suspension	30
051131-52593	3M™ 1916 Omega II™ Hard Hat, Blue, Ratchet Suspension	30

## 3M™ Safety Goggles 1621, Splash-Proof

3M™ Safety Goggles, Splash-Proof have a polycarbonate lens to protect against chemical splashes. Pliable vinyl frames provide comfortable fit and vents enhance air circulation to prevent fogging.



Part Number	Description	Each Per Pack	Packs Per Case
051138-76798	1621 Safety Goggles, Splash-Proof	1	288



Bump Cap

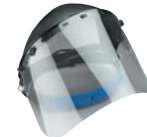

Faceshield Kit



Replacement Visor



Omega II™ Hard Hat



Hard Hat



Replacement Standard Suspension

Part Number	Description	Each Per Case
051138-76815	1913 Omega II™ Hard Hat, Orange, Ratchet Suspension	30
051138-76816	1914 Replacement Ratchet Suspension (for Omega II™ Hard Hat)	30
051138-76817	1921 Hard Hat, White	30
051138-76818	1922 Hard Hat, Yellow	30
051138-76819	1923 Hard Hat, Orange	30
051131-52595	1925 Hard Hat, Red	30
051131-52596	1926 Hard Hat, Blue	30
051138-76820	1924 Replacement Suspension (for 3M™ Hard Hat)	10
051131-76831	1950 Replacement Brow Pad (for 3M™ Hard Hat)	10

# 3M™ Head, Eye and Face Protection

## 3M™ Protective Eyewear

3M Protective Eyewear products are designed to enhance safety in the workplace. In addition, they combine personal comfort, and a fashionable appearance with overall value. All products feature fashionable good looks, a comfortable and secure fit with wraparound design, lightweight plastic frames, and compliance with ANSI Z89.1-1989 requirements.

## 3M™ Vipers™ Protective Eyewear

3M™ Vipers™ Protective Eyewear have a stylish one-piece wraparound design for good looks and optimal protection.



Part Number	Description	Each Per Pack	Packs Per Case
051131- <b>37105</b>	1730 Vipers™ Protective Eyewear, Black Frame, Clear Lens	1	24
051138- <b>76807</b>	1731 Vipers™ Protective Eyewear, Blue Frame, Clear Lens	1	24
051131- <b>37108</b>	1733 Vipers™ Protective Eyewear, Black Frame, Amber Lens	1	24

## 3M™ Lazers™ Protective Eyewear

3M™ Lazers™ Protective Eyewear have a wraparound design with a non-slip rubber headgrip for added comfort.



Part Number	Description	Each Per Pack	Packs Per Case
051138- <b>76804</b>	1720 Lazers™ Protective Eyewear, Black Frame, Clear Lens	1	24
051138- <b>76805</b>	1721 Lazers™ Protective Eyewear, Black Frame, Silver Mirrored Lens	1	24
051138- <b>76806</b>	1722 Lazers™ Protective Eyewear, Red, White, Blue Frame, Clear Lens	1	24
051131- <b>37109</b>	1723 Lazers™ Protective Eyewear, Black Frame, Amber Lens	1	24

## 3M™ Sting-Rays™ Protective Eyewear

3M™ Sting-Ray™ Protective Eyewear have lightweight, contemporary style frames that offer side and brow protection. The lens are made of durable, hardcoated polycarbonate.



Part Number	Description	Each Per Pack	Packs Per Case
051131- <b>37104</b>	1710 Sting-Rays™ Protective Eyewear, Black Frame, Clear Lens	1	24
051138- <b>76802</b>	1711 Sting-Rays™ Protective Eyewear, Blue Frame, Clear Lens	1	24
051138- <b>76803</b>	1712 Sting-Rays™ Protective Eyewear, Black Frame, Smoke Lens	1	24

## 3M™ Boas™ Protective Eyewear

3M™ Boas™ Protective Eyewear have UV Protection up to 99%. They are lightweight and designed for worker acceptance. Lens made of durable, hardcoated polycarbonate. For outdoor or bright environments.



Part Number	Description	Each Per Pack	Packs Per Case
051131- <b>37103</b>	1700 Boas™ Protective Eyewear, Black Frame, Clear Lens	1	24
051138- <b>76800</b>	1701 Boas™ Protective Eyewear, Smoke Frame, Smoke Lens	1	24
051138- <b>76801</b>	1702 Boas™ Protective Eyewear, Clear Frame, Clear Lens	1	24

## 3M™ Thrashers™ Protective Eyewear

3M™ Thrashers™ Protective Eyewear combine durability, style and comfort along with an affordable price, to help make this product an exceptional value.



It features a rectangular shaped lens and wrap-around frame. The new style is available in three different lens options: clear, mirrored and amber.

	Part Number	Description	Each Per Pack	Packs Per Case
NEW	051131- <b>37110</b>	1740 Thrashers™ Protective Eyewear, Clear Lens	1	24
NEW	051131- <b>37111</b>	1741 Thrashers™ Protective Eyewear, Mirror Lens	1	24
NEW	051131- <b>37112</b>	1743 Thrashers™ Protective Eyewear, Amber Lens	1	24

# Personal Care Products

## 3M™ Paint Buster™ Hand Cleaner

3M™ Paint Buster™ Hand Cleaner is a cream type hand cleaner that offers superior performance in the removal of marine bottom and topside paints, primers, varnishes, fairing compounds, putties, adhesives and sealants from skin. 3M™ Paint Buster™ Hand Cleaner is non-toxic and non-caustic, enabling quick removal of marine repair and refinish materials from hands without the use of skin damaging solvents.



Part Number	Container Size	Tubes Per Case
051131-05975	10.5 fl. oz. Tube	12

## 3M™ Nexcare™ Active™ Flexible Foam Bandages

3M™ Nexcare™ Active™ Flexible Foam Bandages feature an advanced moisture-resistant adhesive that provides extra sticking power on damp or sweaty skin. Bandage stays put during work and resists coming off when immersed in water. 3M™ Nexcare™ Active™ Flexible Foam Bandages are made of a unique, flexible foam that stretches, flexes and conforms, unlike many conventional plastic bandages that can curl up, fall off or chaff the skin. The adhesive strip forms a frame around the pad to help seal out dirt and contaminants.



Part Number	UPC Number	Size	Each Per Box	Boxes Per Case
51645	051131-62030	Assorted Pack:	45	24
		10 – 7/8" x 3" Strips		
		10 – 5/8" x 3" Strips		
		10 – 7/8" Spots		
		15 – 3/8" x 1-1/2" Strips		

## 3M™ Nexcare™ Waterproof Bandages

3M™ Nexcare™ Waterproof Bandages have a unique shape that provide superior waterproof protection even when showering and bathing. They help prevent infection by forming a barrier to keep bacteria from cuts, scrapes, burns, blisters and other minor injuries. 3M™ Nexcare™ Waterproof Bandages are made of ultra-thin, breathable material that bends and flexes as you move; the non-stick pad won't stick to the wound. These bandages are transparent and a perfect match to your skin.



Part Number	UPC Number	Size	Each Per Box	Boxes Per Case
58830	051131-66427	Assorted Pack:	30	24
		15 – 7/8" Spots		
		10 – 1-1/16" x 2-1/4" Strips		
		5 – 1-1/4" x 2-1/2" Strips		

## 3M™ First Aid Kits

Sometimes, no matter how many precautions are taken, minor cuts, scrapes and bruises can happen. And when they do, it's important to have quality first aid products close by. That's why we offer 3M™ First Aid Kits – one for the home and workshop, and another to take to the jobsite. Each kit contains the highest quality and most frequently needed items for first aid. It even comes enclosed in a convenient weatherproof carrying case. So your customers can get the care they need, when and where they need it.

	Part Number	Size	Kits Per Case
NEW	051131-80040	13.3" x 8.9" x 6.4"	4
NEW	051131-80041	13.6" x 10.7" x 8.2"	4

## 3M™ Ultrathon™ Insect Repellent

Rated #1 by a leading consumer magazine. Ultrathon's patented 3M Controlled Release Technology works for up to twelve hours – long after other repellents have dissipated. 3M™ Ultrathon™ creates a barrier that repels mosquitos that may carry West Nile Virus, ticks that may carry Lyme Disease, plus biting flies, chiggers, and more. It also resists perspiration for extraordinary effectiveness.



	Part Number	Container Size	Tubes Per Case
NEW	051131-67442	2 oz. Tube	12

## 3M™ Nexcare™ Comfort Strips

Comfort strips have a soft, velvety material that stretches and conforms. It "breathes" even between the holes to help keep skin dry and cool. The unique air flow pattern allows sweat and moisture to evaporate. The extra stick adhesive resists loosening when wet. The adhesive around the pad area helps to "seal" out dirt and other contaminants.



	Part Number	UPC Number	Size	Each Per Box	Boxes Per Case
NEW	57650	051131-65289	Assorted Pack	50	24
			10 – 3/4" x 3"		
			5 – 1" x 3"		
			10 – 5/8" x 2-1/4"		
			10 – spots		
			15 – mini's		

# Comfort Masks

## 3M™ 8651ES Comfort Mask

The 3M™ 8651ES Comfort Mask. Contains 5 comfort masks.



Part Number	Masks Per Pack	Packs Per Case
8651ES	5	12

## 3M™ 8652ES Comfort Mask

The 3M™ 8652ES Comfort Mask. Contains 15 comfort masks.



Part Number	Masks Per Pack	Packs Per Case
8652ES	15	12

# Retail Packaged Safety Products

## Protection for You

3M is a leading name in comfort masks and respirators. Wherever they are used, people in industry and at home recognize 3M Personal Safety Products for their quality and performance.

With the increased popularity in Do-It-Yourself activities and growing consumer awareness in health and safety, more knowledgeable consumers are demanding more effective Do-It-Yourself protection. So, it's important that you have the best protection possible. The 3M Personal Safety Products program assures you of that kind of protection.

## 3M™ R8511ES Woodworking/Sanding and Fiberglass Respirator

The 3M™ R8511ES Woodworking/Sanding and Fiberglass Respirator provides protection from dusts encountered during sanding jobs (wood or non-lead based fiberglass paint). U.S. government approved. Contains 1 respirator.



Part Number	Respirators Per Pack	Packs Per Case
R8511ES	1	12

## 3M™ 8654ES Sanding and Fiberglass Respirator

The 3M™ 8654ES Sanding and Fiberglass Respirator provides protection against dust encountered during sanding jobs.



Part Number	Respirators Per Pack	Packs Per Case
8654ES	2	12

## 3M™ 8656ES Latex Paint and Odor Respirator

The 3M™ 8656ES Latex Paint and Odor Respirator provides protection against sanding dust and fiberglass insulation dust, particle board, drywall compounds and painted surfaces. Meets requirements of NIOSH 42 CFR 84 N95. This respirator is 95% efficient against solid and liquid aerosols that do not contain oil.



Part Number	Respirators Per Pack	Packs Per Case
8656ES	1	12

## 3M™ 8660ES Welding Respirator

The 3M™ 8660ES Welding Respirator provides protection against dust from wood working, coal, iron ore, cotton, flour and certain other substances; mists from sprays that do not also produce vapors and do not contain oil; metal fumes from welding, brazing, cutting and other operations involving heating of metals. U.S. government approved. Contains 1 respirator.



Part Number	Respirators Per Pack	Packs Per Case
8660ES	1	6

## 3M™ 8658ES Corded Ear Plugs

The 3M™ 8658ES Corded Ear Plugs provide protection against loud noises. Conformable. Two pairs per package.



Part Number	Pairs Per Pack	Packs Per Case
8658ES	2	12

# Retail Packaged Safety Products

## 3M™ Particulate Filter 2071, P95 — Retail Packaged

Lightweight and easy to use, the 3M™ 2071 P95 Particulate Filter is designed for applications such as grinding, sanding and welding. It provides approved protection in environments where oil aerosols may be present. Can be used with 3M™ 5000 Series Respirators when equipped with the 502 adapter (adapter must be ordered separately.) Retail packaged.



	Part Number	UPC Number	Each Per Box	Boxes Per Case
NEW	R2071	051138-76681	4	5

## 3M™ Particulate Filter 2091, P100 — Retail Packaged

Meets the NIOSH 42 CFR 84 filtration classification, P100. The 2091 does so with 3M's new Advanced Electret Media (AEM). Currently, it is the only filter not made from fiberglass components to achieve a P100 rating. Use for all applications that in the past required the use of dust/mist, dust/fume/mist class or HEPA-rated respiratory protection. The 2091 is lightweight, versatile, simple to use, compatible, exceptionally efficient respiratory filter and priced competitively. Retail packaged.



	Part Number	UPC Number	Each Per Box	Boxes Per Case
NEW	R2091	051138-76582	4	5

## 3M™ Paint Spray Replacement 6000 Series — Retail Packaged

Cartridge can be used with 3M™ 6000 Series Half Facepiece and Full Facepiece Respirator with bayonet attachment. Retail Packaged.



	Part Number	UPC Number	Each Per Case
NEW	R6022	051138-54270	5

## 3M™ Replacement Lens Covers 6000 Series — Retail Package

Faceshield cover for use with the 3M™ 6000 Series Full Facepiece Respirator. Packaged 25 per bag for retail sale.



	Part Number	UPC Number	Each Per Bag	Bags Per Case
NEW	R6885ES	051131-52634	25	4

## 3M™ Ear Muff 1425 — Retail Package

Lightweight, economical ear muffs designed for comfort and durability in most work environments. Packaged 1 per header carded bag for retail sale.



	Part Number	UPC Number	Each Per Case
NEW	R1425ES	051131-52600	10

## 3M™ Ear Muff 1427 — Retail Package

A combination of versatility and performance. The rotating headband and adjustable head strap make it easy to obtain a secure fit in any of three different positions. Packaged 1 per header carded bag for retail sale.



	Part Number	UPC Number	Each Per Case
NEW	R1427ES	051131-52601	10

## 3M™ Visitor Specs 1611 Clear — Retail Package

3M™ Visitor Specs provide eye protection for temporary visitors, and short term users. Can be worn alone or over prescription glasses. Individually carded for retail sale.

	Part Number	UPC Number	Each Per Case
NEW	R1611ES	051131-52522	10

## 3M™ Safety Goggles 1620 Perforated — Retail Package

3M™ Safety Goggles are perforated, soft and comfortable with flexible vinyl frames. These are goggles for general use and should not be worn in areas where chemical splashes and fumes may be present. Individually carded for retail sale.

	Part Number	UPC Number	Each Per Case
NEW	R1620ES	051131-52523	15

## 3M™ Safety Goggles 1621 Splash-Proof — Retail Package

3M™ Safety Goggles, Splash-Proof have a polycarbonate lens to protect against chemical splashes. Pliable vinyl frames provide comfortable fit and vents enhance air circulation to prevent fogging. Individually carded for retail sale.

	Part Number	UPC Number	Each Per Case
NEW	R1621ES	051131-52524	15

# Retail Packaged Safety Products

## 3M™ Boas™ Protective Eyewear — Retail Package

3M™ Boas™ Protective Eyewear have UV Protection up to 99%. They are lightweight and designed for worker acceptance. Lens made of durable, hardcoated polycarbonate. For outdoor or bright environments. The R-1701ES style has a tinted lens. Individually carded for retail sale.

	Part Number	UPC Number	Each Per Case
NEW	R1700ES	051131-52526	10
NEW	R1701ES	051131-52527	10

## 3M™ Sting-Rays™ Protective Eyewear — Retail Package

3M™ Sting-Rays™ Protective Eyewear have lightweight, contemporary style frames that offer side and brow protection. The lenses are made of durable, hardcoated polycarbonate. The R-1712ES style has a tinted lens. Individually carded for retail sale.

	Part Number	UPC Number	Each Per Case
NEW	R1710ES	051131-52528	10
NEW	R1712ES	051131-52529	10

## 3M™ Lazers™ Protective Eyewear — Retail Package

3M™ Lazers™ Protective Eyewear have a wraparound design with a non-slip rubber headgrip for added comfort. The R-1721ES style has a mirrored lens. Individually carded for retail sale.

	Part Number	UPC Number	Each Per Case
NEW	R1720ES	051131-52530	10
NEW	R1721ES	051131-52531	10

## 3M™ Faceshield Kit — Retail Package

3M™ Faceshield Kit uses replaceable polycarbonate material for clearer vision. The cam-lock feature holds the faceshield in place. It uses a slide adjustment for easy sizing. Packaged one per header carded bag for retail sale.

	Part Number	UPC Number	Kits Per Case
NEW	R1631ES	051131-52525	5

## 3M™ Head Protection Products — Retail Package

3M™ Head and Face Protection Products are designed to enhance safety in the work place. In addition, they combine personal comfort, and a fashionable appearance with overall value. All 3M™ Head Protection Products feature lightweight, high-density polyethylene molding, fully cushioned brow pads for moisture absorption, a 6-point suspension and compliance with ANSI Z89.1-1997 Type 1, Class C, E, and G requirements. Omega II Hard Hats – standard slide suspension adjusts to fit sizes 6-1/2 to 7-1/4. Ratchet suspension fits 5-1/8 to 8. Ratchet has soft removable head band for maximum adjustability and comfort. Key advantages are: meets ANSI requirements, available in variety of colors, styles and suspensions, can be worn backwards by adjusting suspension, front brimmed or full brim styles available. All are packaged one per header carded bag for retail sale.

	Part Number	UPC Number	Description	Each Per Case
NEW	R1911ES	051131-52532	Omega II™ Hard Hat, White, Ratchet Suspension	8
NEW	R1912ES	051131-52533	Omega II™ Hard Hat, Yellow, Ratchet Suspension	8
NEW	R1921ES	051131-52534	Hard Hat, White	8
NEW	R1922ES	051131-52535	Hard Hat, Yellow	8
NEW	R1931ES	051131-52536	Full Brim Hard Hat, White, Ratchet Suspension	8
NEW	R1932ES	051131-52537	Full Brim Hard Hat, Yellow, Ratchet Suspension	8

## 3M™ 7500 Professional Series Organic Vapor P95 Half Mask Respirator Packout — Retail Package

The 3M™ Professional Series Organic Vapor P95 Packout is 3M recommended for paint spray applications. Packouts include the ultracomfortable Professional Series Facepiece, two 6001 organic vapor cartridges, four 5P71, P95 filters and two 501 retainers. Packed for retail sale.



	Part Number	UPC Number	Description	Packouts Per Case
NEW	R7511ES	051131-52764	Small Respirator Packout	4
NEW	R7512ES	051131-52765	Medium Respirator Packout	4
NEW	R7513ES	051131-52766	Large Respirator Packout	4

## 3M™ Professional Series Half Facepiece Respirator Rebuild Kit

Includes replacement parts to maintain the durable respirator facepiece. Packed for retail sale.

	Part Number	UPC Number	Description	Packouts Per Case
NEW	R7530ES	051131-52767	Kit	5

# Fluid Recovery Products

## 3M™ Environmental Safety Products

### 3M™ Petroleum Sorbents — For Use in “Hydrophobic” (oil only) Sorbent Applications

3M™ Sorbents help contain and control potentially dangerous spills of oil and gasoline . . . but repel water! 3M™ Sorbents go to work immediately so there's less exposure to you and others and less risk to the environment. 3M™ Sorbents are available in several different forms to meet most of your needs.



Part Number	Approx. Dimensions/ Sorbent Capacity	Packaging
<b>Rolls</b>		
<b>T100</b>	38" x 144' x 3/8" (51 Gallons/Rolls)	1 Roll/Bag
<b>HP100</b>	38" x 144' x 1/4" (51 Gallons/Rolls)	1 Roll/Bag
<b>Sweeps</b>		
<b>T126</b>	17" x 100' x 3/8" (17 Gallons/Sweep)	1 Sweep/Bale
<b>Pads</b>		
<b>T151</b>	17" x 19" x 3/16" (.13 Gallons/Pad)	200 Pads/Bale
<b>T156</b>	17" x 19" x 3/8" (.25 Gallons/Pad)	100 Pads/Bale
<b>T157</b>	34" x 38" x 3/8" (1 Gallon/Pad)	50 Pads/Bale
<b>HP156</b>	17" x 19" x 1/4" (.25 Gallons/Pad)	100 Pads/Bale
<b>HP157</b>	34" x 38" x 1/4" (1 Gallon/Pad)	50 Pads/Bale
<b>HP255</b>	17" x 19" x 1/2" (.50 Gallons/Pad)	50 Pads/Bale
<b>HP256</b>	17" x 19" x 1/2" (.50 Gallons/Pad)	100 Pads/Bale

### 3M™ Petroll 5-Gallon Petroleum Spill Kit

3M™ Petroll can be used for containing and absorbing petroleum-based liquid spills of up to 5 gallons. Conformable, 3M™ Petroll is an excellent solution for storage where space is limited. Because 3M™ Petroll uses 3M's Petroleum Sorbent-Folded technology, it can be used as booms, pillows, pads or roll, making it the most versatile response product available on the market today.



Part Number	Kit Contents	Kits Per Case
<b>PSKFL5</b>	5" x 26' With perforations every 16" (19" x 26' fully opened) One temporary disposal bag and tie	3

### 3M™ Marine Oil and Fuel Absorbent Bilge Pillow

Holds up to two quarts of oil. Just toss the pillow in the bilge, and it soaks up oil and gasoline, but repels water! The bilge water can then be pumped overboard legally. The pillow includes a special grommeted hole which can be used to tie the pillow in place.



Part Number	Approx. Dimensions/ Sorbent Capacity	Pillows Per Case
<b>29026</b>	7" x 15" (.5 Gallons/Pillow)	16

Part Number	Approx. Dimensions/ Sorbent Capacity	Packaging
<b>Particulate</b>		
<b>T210</b>	25 lbs./Bag (35 Gallons/Bag)	1 Bag/Bale

Part Number	Approx. Dimensions/ Sorbent Capacity	Pillows/ Bale
<b>Pillows</b>		
<b>T240</b>	5" x 14" x 25" 2 lbs./Pillow (3.5 Gallons/Pillow)	10 Pillows/Bale
<b>T30</b>	7" x 15" (.50 Gallons/Pillow) Pillows/Case	16

Part Number	Approx. Dimensions/ Sorbent Capacity	Booms/ Bale
<b>Sorbent Booms</b>		
<b>T270</b>	8" Diameter x 10' 10 lbs./Boom (20 Gallons/Boom)	4 Booms/Bale
<b>T280</b>	5" Diameter each x 10' 6.5 lbs./Double Boom (10 Gallons/Boom)	4 Double Booms/Bale

Part Number	Approx. Dimensions/ Sorbent Capacity	Boxes/ Case
<b>Folded</b>		
<b>PFL550DD</b>	5" x 50'/Box (8 Gallons/Box)	3 Boxes/Case

# Fluid Recovery Products

## 3M™ 31-Gallon Petroleum Spill Kit

This spill kit combines the best of both worlds, petroleum sorbent-folded (which can be used as booms, pillows or roll) and high capacity petroleum sorbent pads. This unique combination allows you to easily select the product to fit the response. Packaged in a white 20-gallon drum, the kit can be placed in key locations where fuels or other petroleum-based fluids may be released. The drum is also water, chemical and ultraviolet (U.V.) resistant - perfect for outside storage. And for fast transport to a spill site, we've included handy, easy-to-grip handles around the drum.



Part Number	Kit Contents	Kits Per Case
<b>PSKFL31</b>	Petroleum Sorbent-Folded (P-FL550DD) – 2 Rolls 5" x 50' Folded (19" x 50' fully opened) Petroleum Sorbent Pads (HP-156) – 30 Each 17" x 19" Temporary Disposal Bags and Ties – 3 White drum with lid and plastic closure ring – 1 Each 20 Gallon	1

## 3M™ Maintenance Sorbents — For Use on Most “Non-Aggressive” Liquids

Designed to absorb oil, cutting most other types of fluid, the 3M™ Maintenance Sorbents are ideal in the marine shop environment. Available in a variety of forms, they help clean and maintain work areas from dripping and leaking equipment around floors, work benches, 55 gallon drums and walkways. Excellent to use during on-board engine repair work.



Part Number	Approx. Dimensions/ Sorbent Capacity	Each Per Case
<b>Folded</b>		
<b>MFL550DD</b>	5" x 50'/Box (9 Gallons/Box)	3
<b>Rolls</b>		
<b>MRL15150DD</b>	15-1/2" x 150' Roll (20 Gallons/Case)	1
<b>MRL38150DD</b>	38" x 150' Roll (50 Gallons/Case)	1
<b>Drum Covers</b>		
<b>MDC22DD</b>	22" Drum Cover w/skirt (13 Gallons/Case)	25
<b>Rugs</b>		
<b>MRG36300E</b>	36" x 300' Rug (32 Gallons/Roll)	1
<b>MRGC36100E</b>	36" x 100' Rug w/coating (10.5 Gallons/Roll)	1



# Slip Resistant Products

## 3M™ Safety-Walk™ General Purpose Slip Resistant Surfacing

3M™ Safety-Walk™ General Purpose Slip Resistant Surfacing is a high-friction textured material. It consists of abrasive mineral particles bonded by a tough, durable polymer to a dimensionally stable plastic film. The backing is coated with a pressure-sensitive adhesive covered by a removable protective liner.

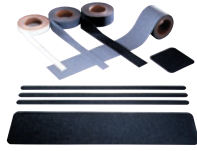

Part Number	Size	Color	Each Per Case
048011-19217	3/4" x 24"	Black	50
048011-19216	5-1/2" x 5-1/2"	Black	50
048011-19218	6" x 24"	Black	50
048011-19219	3/4" x 60'	Black	4
048011-19220	1" x 60'	Black	4
048011-19221	2" x 60'	Black	2
048011-19223	4" x 60'	Black	1
048011-19224	6" x 60'	Black	1
048011-19235	12" x 60'	Black	1
048011-19238	18" x 60'	Black	1
048011-19236	24" x 60'	Black	1
048011-19239	36" x 60'	Black	1
048011-19237	48" x 60'	Black	1
048011-26417	1" x 60'	Clear	4
048011-26419	2" x 60'	Clear	2
048011-26418	4" x 60'	Clear	1
048011-19249	1" x 60'	Yellow	4
048011-19250	2" x 60'	Yellow	2
048011-19251	4" x 60'	Yellow	1

## 3M™ Safety-Walk™ General Purpose Surfacing — Heavy Duty Deal (S-124) — Black

Surfacing has a diamond hard mineral surface for extra traction. It is designed for use around areas of heavy traffic. Deal contains one roll each of 3M™ Safety-Walk™ General Purpose Tread Pieces and Rolls (PNs 07731, 07732, and 07733) plus an attractive dispenser rack.



Part Number	Deals Per Case
07730	1

Part Number	Size	Rolls Per Case
<b>Replacement Rolls for Deal S-124 — Black</b>		
07731	1" x 60 ft.	12
07732	2" x 60 ft.	6
07733	4" x 60 ft.	3

## 3M™ Safety-Walk™ General Purpose Surfacing — Heavy Duty Deal (S-124) — Clear

Designed for use in areas of heavy traffic, this product satisfies the need for a non-skid safety product that coordinates with any color of substrate. Deal contains one roll each of 3M™ Safety-Walk™ General Purpose Tread Pieces and Rolls (PNs 07747, 07748, and 07749) plus an attractive dispenser rack.



Part Number	Deals Per Case
07729	1

Part Number	Size	Rolls Per Case
<b>Replacement Rolls for Deal S-124 — Clear</b>		
07747	1" x 60 ft.	12
07748	2" x 60 ft.	6
07749	4" x 60 ft.	3

## 3M™ Safety-Walk™ Conformable Slip Resistant Surfacing

3M™ Safety-Walk™ Conformable Slip Resistant Surfacing is a high-friction textured material. It consists of abrasive particles bonded by a tough, durable polymer to an aluminum foil backing. The backing is coated with a pressure-sensitive adhesive covered by a removable protective liner.



Part Number	Size	Color	Each Per Case
048011-19278	5-1/2" x 5-1/2"	Black	50
048011-19279	6" x 24"	Black	50
048011-19280	2" x 60'	Black	2
048011-19281	4" x 60'	Black	1
048011-19282	6" x 60'	Black	1
048011-19283	12" x 60'	Black	1
048011-19284	18" x 60'	Black	1
048011-19285	24" x 60'	Black	1
048011-19288	2" x 60'	Yellow	2
048011-19289	4" x 60'	Yellow	1
048011-19290	6" x 60'	Yellow	1

# Slip Resistant Products

## 3M™ Safety-Walk™ Resilient Slip Resistant Surfacing — Medium Grade

3M™ Safety-Walk™ Medium Grade Resilient Slip Resistant Surfacing is a high-friction resilient textured material. The product consists of a dimensionally stable plastic film coated with a textured resilient surface. The reverse surface is coated with a pressure-sensitive adhesive covered by a removable protective liner.



Part Number	Size	Color	Each Per Case
048011-19292	6" x 24"	Black	50
048011-19293	1" x 60'	Black	4
048011-19294	2" x 60'	Black	2
048011-19296	4" x 60'	Black	1
048011-19297	6" x 60'	Black	1
048011-19298	12" x 60'	Black	1
048011-19299	18" x 60'	Black	1
048011-19300	24" x 60'	Black	1
048011-19301	36" x 60'	Black	1
048011-19302	48" x 60'	Black	1
048011-19320	6" x 24"	Gray	50
048011-19321	1" x 60'	Gray	4
048011-19323	2" x 60'	Gray	2
048011-19322	4" x 60'	Gray	1
048011-19324	6" x 60'	Gray	1
048011-19325	12" x 60'	Gray	1
048011-19326	18" x 60'	Gray	1
048011-19327	24" x 60'	Gray	1
048011-19328	36" x 60'	Gray	1

## 3M™ Safety-Walk™ Resilient Slip Resistant Surfacing — Fine Grade

3M™ Safety-Walk™ Fine Grade Resilient Slip Resistant Surfacing is a high-friction resilient textured material. The product consists of a fine textured resilient top surface. The reverse side is coated with a pressure-sensitive adhesive covered by a removable protective liner.



Part Number	Size	Color	Each Per Case
048011-19315	1" x 60'	White	4
048011-19316	2" x 60'	White	2
048011-19317	4" x 60'	White	1
048011-19318	6" x 60'	White	1
048011-19319	12" x 60'	White	1
048011-19303	1" x 60'	Clear	4
048011-19304	2" x 60'	Clear	2
048011-19305	12" x 60'	Clear	1

## 3M™ Safety-Walk™ Resilient Slip Resistant Surfacing — Medium Duty Deal (H-124) — Black

3M™ Safety-Walk™ Medium Duty Resilient Slip Resistant Surfacing has a textured polymer surface that offers both traction enhancement and resilient characteristics. Generally used around barefoot or deck shoe areas such as decks of boats, docks, showers and recreation rooms. Deal contains one roll each of 3M™ Safety-Walk™ Medium Duty Resilient Slip Resistant Surfacing (PNs 07736, 07737, and 07738) plus an attractive dispenser rack.



Part Number	Deals Per Case
07734	1

Part Number	Size	Rolls Per Case
<b>Replacement Rolls for Deal H-124 — Black</b>		
07736	1" x 60 ft.	12
07737	2" x 60 ft.	6
07738	4" x 60 ft.	3

## 3M™ Safety-Walk™ Resilient Slip Resistant Surfacing — Medium Duty Deal (H-124) — Gray

Use in the same applications as 3M™ Safety-Walk™ Resilient Slip Resistant Surfacing - Medium Duty Deal (H-124) - Black where gray is the preferred color. Deal contains one roll each of 3M™ Safety-Walk™ Medium Duty Resilient Slip Resistant Surfacing (PNs 07739, 07740, and 07741) plus an attractive dispenser rack.

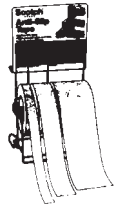

Part Number	Deals Per Case
07735	1

Part Number	Size	Rolls Per Case
<b>Replacement Rolls for Deal H-124 — Gray</b>		
07739	1" x 60 ft.	12
07740	2" x 60 ft.	6
07741	4" x 60 ft.	3

# Slip Resistant Products

## 3M™ Safety-Walk™ Resilient Slip Resistant Surfacing — Light Duty Deal (M-124) — White

A fine textured polymer, 3M™ Safety-Walk™ Light Duty Resilient Slip Resistant Surfacing - White finds many uses on boat decks, around and in pools and bath tubs and showers. Deal contains one roll each of 3M™ Safety-Walk™ Light Duty Resilient Slip Resistant Surfacing (PNs 07743, 07744, and 07745) plus an attractive dispenser rack.



Part Number	Deals Per Case
07742	1

Part Number	Size	Rolls Per Case
<b>Replacement Rolls for Deal H-124 — White</b>		
07743	1" x 60 ft.	12
07744	2" x 60 ft.	6
07745	4" x 60 ft.	3

## 3M™ Safety-Walk™ Resilient Slip Resistant Surfacing — Light Duty Deal (M-124) — Clear

Fine textured, 3M™ Safety-Walk™ Light Duty Resilient Slip Resistant Surfacing - Clear may be used on boat decks, around pools, bath tubs and showers. Satisfies the need for a light duty non-skid product that coordinates with any color of substrate. Deal contains one roll each of 3M™ Safety-Walk™ Light Duty Resilient Slip Resistant Surfacing (PNs 07751, 07752, and 07753) plus an attractive dispenser rack.



Part Number	Deals Per Case
07750	1

Part Number	Size	Rolls Per Case
<b>Replacement Rolls for Deal M-124 — Clear</b>		
07751	1" x 60 ft.	12
07752	2" x 60 ft.	6
07753	4" x 60 ft.	3

## 3M™ Safety-Walk™ Application Accessories

### 3M™ Safety-Walk™ Primer

The product is a liquid solvent-based adhesive applied to porous surfaces before applying traction enhancement products. One quart covers approximately 35 square feet.



Part Number	Container Size	Containers Per Case
048011-19339	Quart	1

### 3M™ Safety-Walk™ Edge Sealing Compound — No. 5569

Edge Sealing Compound is a liquid solvent-based sealer in a convenient tube applicator. The product seals the exposed edges of 3M™ Safety-Walk™ Slip Resistant products providing extra protection from excessive moisture or liquids. One five ounce tube seals approximately 75 to 100 linear feet.



Part Number	Container Size	Tubes Per Case
048011-19340	5 oz. Tube	1

### 3M™ Safety-Walk™ Rubber Hand Roller

3M™ Safety-Walk™ Rubber Hand Roller helps provide a firm bond when applying all 3M™ Safety-Walk™ products.

Part Number	Size	Rollers Per Case
048011-19341	1-3/8" dia. x 2" wide x 6" long	1

# Anti-Fatigue Matting

## 3M™ Safety-Walk Matting™ Cushion Matting 3400

3M work area matting helps improve people's safety and comfort. Reduced fatigue and discomfort helps improve worker productivity. Improved slip resistance helps reduce accidental slips and falls. Reduced impact on dropped items means less damage to tools and products. Closed-cell, foamed z-web construction helps provide cushioned support, reducing leg and back fatigue. Textured, solid top helps improve traction and allows debris and liquid to stay on top of the mat for easy cleanup.



## 3M™ Safety-Walk Matting™ Cushion Matting 3600

3M work area matting helps improve people's safety and comfort. Reduced fatigue and discomfort helps improve worker productivity. Improved slip resistance helps reduce accidental slips and falls. Reduced impact on dropped items means less damage to tools and products. Closed-cell, foamed z-web construction helps provide cushioned support, reducing leg and back fatigue. Open construction lets liquids and small particles pass through, providing a safer, drier surface while "trapping" debris in the mat until you're ready to clean it up.



Part Number	Size	Color	Description	Each Per Case
048011- <b>23941</b>	34" x 2'	Black	w/o nosing	4
048011- <b>23943</b>	34" x 2'	Black/Yellow	2 edges	4
048011- <b>23944</b>	34" x 2'	Black/Black	2 edges	4
048011- <b>23928</b>	34" x 5'	Black	w/o nosing	1
048011- <b>23930</b>	34" x 5'	Black/Yellow	2 edges	1
048011- <b>23932</b>	34" x 5'	Black/Black	2 edges	1
048011- <b>23933</b>	34" x 10'	Black	w/o nosing	1
048011- <b>23934</b>	34" x 10'	Black/Yellow	2 edges	1
048011- <b>23919</b>	34" x 10'	Black/Black	2 edges	1
048011- <b>23920</b>	34" x 20'	Black	w/o nosing	1
048011- <b>23921</b>	34" x 20'	Black/Yellow	2 edges	1
048011- <b>23923</b>	34" x 20'	Black/Black	2 edges	1
048011- <b>23925</b>	34" x 50'	Black	w/o nosing	1
048011- <b>23942</b>	37" x 2'	Black/Yellow	4 edges	4
048011- <b>23927</b>	37" x 2'	Black/Black	4 edges	4
048011- <b>23931</b>	37" x 5'	Black/Yellow	4 edges	1
048011- <b>23929</b>	37" x 5'	Black/Black	4 edges	1
048011- <b>23935</b>	37" x 10'	Black/Yellow	4 edges	1
048011- <b>23874</b>	37" x 10'	Black/Black	4 edges	1
048011- <b>23922</b>	37" x 20'	Black/Yellow	4 edges	1
048011- <b>23924</b>	37" x 20'	Black/Black	4 edges	1
048011- <b>23926</b>	15" x 17"	Black	w/o nosing	5

Part Number	Size	Color	Description	Each Per Case
048011- <b>23464</b>	35" x 2'	Black	w/ nosing	4
048011- <b>23477</b>	35" x 2'	Black/Yellow	2 edges	4
048011- <b>23479</b>	35" x 2'	Black/Black	2 edges	4
048011- <b>23465</b>	35" x 5'	Black	w/ nosing	1
048011- <b>23481</b>	35" x 5'	Black/Yellow	2 edges	1
048011- <b>23483</b>	35" x 5'	Black/Black	2 edges	1
048011- <b>23466</b>	35" x 10'	Black	w/ nosing	1
048011- <b>23485</b>	35" x 10'	Black/Yellow	2 edges	1
048011- <b>23469</b>	35" x 10'	Black/Black	2 edges	1
048011- <b>23474</b>	35" x 50'	Black	w/o nosing	1
048011- <b>23478</b>	38" x 2'	Black/Yellow	4 edges	4
048011- <b>23480</b>	38" x 2'	Black/Black	4 edges	4
048011- <b>23482</b>	38" x 5'	Black/Yellow	4 edges	1
048011- <b>23484</b>	38" x 5'	Black/Black	4 edges	1
048011- <b>23468</b>	38" x 10'	Black/Yellow	4 edges	1
048011- <b>23470</b>	38" x 10'	Black/Black	4 edges	1

# Floor and Deck Matting

## 3M™ Nomad™ Scraper Matting 6050

3M™ Nomad™ Scraper Matting 6050 is a non-woven open matting formed of continuous vinyl filaments. The mat has an integral fused, all-vinyl foam backing to form a comfortable, cushioned walking surface. This construction provides anti-fatigue as well as dirt trapping and collecting properties.

Part Number	Size	Color	Each Per Case
<b>Embossed "Welcome"</b>			
048011- <b>26495</b>	22" x 34"	Blue	6
048011- <b>26493</b>	22" x 34"	Cabernet	6
048011- <b>26497</b>	22" x 34"	Forest	6
048011- <b>26496</b>	22" x 34"	Silver	6
048011- <b>26491</b>	22" x 34"	Slate (Grey)	6
<b>Non-Embossed "Standard Mat"</b>			
048011- <b>26442</b>	22" x 34"	Blue	6
048011- <b>26431</b>	22" x 34"	Blueberry	6
048011- <b>26432</b>	22" x 34"	Burgundy	6
048011- <b>26440</b>	22" x 34"	Cabernet	6
048011- <b>26441</b>	22" x 34"	Chestnut (Dk. Brown)	6
048011- <b>26436</b>	22" x 34"	Ebony	6
048011- <b>26444</b>	22" x 34"	Forest	6
048011- <b>26433</b>	22" x 34"	Granite	6
048011- <b>26434</b>	22" x 34"	Red	6
048011- <b>26443</b>	22" x 34"	Silver	6
048011- <b>26439</b>	22" x 34"	Slate (Grey)	6
048011- <b>26437</b>	22" x 34"	Spruce	6
048011- <b>26449</b>	3' x 5'	Blue	1

## 3M™ Nomad™ Scraper Matting 6050 (cont.)

Part Number	Size	Color	Each Per Case
048011- <b>17584</b>	3' x 5'	Burgundy	1
048011- <b>26447</b>	3' x 5'	Cabernet	1
048011- <b>26448</b>	3' x 5'	Chestnut (Dk. Brown)	1
048011- <b>17780</b>	3' x 5'	Ebony	1
048011- <b>26451</b>	3' x 5'	Forest	1
048011- <b>26187</b>	3' x 5'	Dove (Brown)	1
048011- <b>17580</b>	3' x 5'	Red	1
048011- <b>26446</b>	3' x 5'	Seagrey	1
048011- <b>26450</b>	3' x 5'	Silver	1
048011- <b>26445</b>	3' x 5'	Slate (Grey)	1
048011- <b>17782</b>	3' x 5'	Spruce	1
048011- <b>26456</b>	4' x 6'	Blue	1
048011- <b>26453</b>	4' x 6'	Cabernet	1
048011- <b>26455</b>	4' x 6'	Chestnut (Dk. Brown)	1
048011- <b>17790</b>	4' x 6'	Ebony	1
048011- <b>26458</b>	4' x 6'	Forest	1
048011- <b>26189</b>	4' x 6'	Dove (Brown)	1
048011- <b>17788</b>	4' x 6'	Red	1
048011- <b>26454</b>	4' x 6'	Seagrey	1
048011- <b>26457</b>	4' x 6'	Silver	1
048011- <b>26452</b>	4' x 6'	Slate (Grey)	1

# Floor and Deck Matting

## 3M™ Nomad™ Scraper Matting 8100

3M™ Nomad™ Scraper Matting 8100 combines vinyl loops that scrape dirt and moisture from shoes with an unbacked construction that makes it easy to clean up the debris that falls through the mat. This grease- and oil-resistant matting is designed for exterior facility entrances or recessed wells.

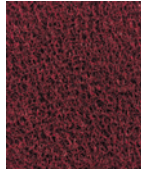

## 3M™ Nomad™ Scraper Matting 8150

3M™ Nomad™ Scraper Matting 8150 combines vinyl loops that scrape dirt and moisture from shoes with a durable backing that keeps dirt and moisture from falling through the mat onto the floor underneath. This grease- and oil-resistant matting is designed for exterior or interior facility entrances or recessed wells.



Part Number	Size	Color	Each Per Case
NEW 048011- <b>29462</b>	3' x 5'	Dove (Brown)	1
NEW 048011- <b>29463</b>	3' x 5'	Red	1
NEW 048011- <b>29466</b>	3' x 5'	Ebony	1
NEW 048011- <b>29467</b>	3' x 5'	Concrete (Lt. Grey)	1
NEW 048011- <b>29464</b>	4' x 6'	Concrete (Lt. Grey)	1
NEW 048011- <b>29465</b>	4' x 6'	Red	1
NEW 048011- <b>28468</b>	4' x 6'	Ebony	1
NEW 048011- <b>29469</b>	4' x 6'	Dove (Brown)	1
NEW 048011- <b>26515</b>	4' x 6'	Slate (Grey)	1
NEW 048011- <b>26516</b>	4' x 6'	Seagrey	1
NEW 048011- <b>46517</b>	4' x 6'	Cabernet	1
NEW 048011- <b>26518</b>	4' x 6'	Chestnut (Dk. Brown)	1
NEW 048011- <b>26519</b>	4' x 6'	Blue	1
NEW 048011- <b>26520</b>	4' x 6'	Silver	1
NEW 048011- <b>26521</b>	4' x 6'	Forest	1
NEW 048011- <b>26293</b>	3' x 20'	Unbacked Dove (Brown)	1
NEW 048011- <b>26291</b>	3' x 20'	Unbacked Slate (Grey)	1
NEW 048011- <b>34501</b>	4' x 20'	Unbacked Dove (Brown)	1
NEW 048011- <b>34635</b>	4' x 20'	Slate (Grey)	1

Part Number	Size	Color	Each Per Case
NEW 048011- <b>26464</b>	3' x 5'	Slate (Grey)	1
NEW 048011- <b>26465</b>	3' x 5'	Seagrey	1
NEW 048011- <b>26466</b>	3' x 5'	Cabernet	1
NEW 048011- <b>26467</b>	3' x 5'	Chestnut (Dk. Brown)	1
NEW 048011- <b>26468</b>	3' x 5'	Blue	1
NEW 048011- <b>26469</b>	3' x 5'	Silver	1
NEW 048011- <b>26470</b>	3' x 5'	Forest	1
NEW 048011- <b>29473</b>	3' x 5'	Ebony	1
NEW 048011- <b>29474</b>	3' x 5'	Dove (Brown)	1
NEW 048011- <b>29477</b>	3' x 5'	Red	1
NEW 048011- <b>26477</b>	4' x 6'	Slate (Grey)	1
NEW 048011- <b>26478</b>	4' x 6'	Seagrey	1
NEW 048011- <b>26479</b>	4' x 6'	Cabernet	1
NEW 048011- <b>26480</b>	4' x 6'	Chestnut (Dk. Brown)	1
NEW 048011- <b>26481</b>	4' x 6'	Blue	1
NEW 048011- <b>26482</b>	4' x 6'	Silver	1
NEW 048011- <b>26483</b>	4' x 6'	Forest	1
NEW 048011- <b>29470</b>	4' x 6'	Ebony	1
NEW 048011- <b>29471</b>	4' x 6'	Dove (Brown)	1
NEW 048011- <b>29472</b>	4' x 6'	Red	1
NEW 048011- <b>29476</b>	4' x 6'	Concrete (Lt. Grey)	1
NEW 048011- <b>34563</b>	3' x 20'	Backed Dove (Brown)	1
NEW 048011- <b>34562</b>	3' x 20'	Backed Slate (Grey)	1
NEW 048011- <b>34556</b>	4' x 20'	Backed Dove (Brown)	1
NEW 048011- <b>34557</b>	4' x 20'	Backed Slate (Grey)	1

# Floor and Deck Matting

## 3M™ Nomad™ Scraper Matting 6050

Designed to be the first mat of a 3M entrance matting system, 3M™ Nomad™ Scraper Matting 6050 has vinyl loops that scrape dirt and moisture from shoes. Its backing keeps dirt and water off the floor underneath when used for indoor applications. Designed for medium traffic facility entrances.

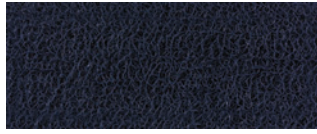

## 3M™ Safety-Walk™ Matting Wet Area Matting 1500

Also known as 3M™ Nomad™ Medium Traffic Unbacked Matting; 3M™ Safety-Walk™ Wet Area Matting 1500 has an open, coiled vinyl construction allowing water to drain through, making it ideal for locker rooms, shower areas and around saunas. The cushioned vinyl loops provide comfort for barefoot traffic. Antimicrobial coating provides resistance to mildew, fungus and odors in the mat. This matting is easy to maintain – just clean by shaking or washing with a hose or power washer.

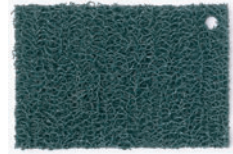

Part Number	Size	Color	Each Per Case
NEW 048011-26182	22" x 34"	Concrete (Lt. Grey)	6
NEW 048011-26183	22" x 34"	Dove (Brown)	6
NEW 048011-26433	22" x 34"	Seagrey	6
NEW 048011-26436	22" x 34"	Ebony	6
NEW 048011-26437	22" x 34"	Red	6
NEW 048011-26439	22" x 34"	Slate (Grey)	6
NEW 048011-26440	22" x 34"	Cabernet	6
NEW 048011-26441	22" x 34"	Chestnut (Dk. Brown)	6
NEW 048011-26442	22" x 34"	Blue	6
NEW 048011-26443	22" x 34"	Silver	6
NEW 048011-26444	22" x 34"	Forest	6
NEW 048011-17580	3' x 5'	Red	1
NEW 048011-17780	3' x 5'	Ebony	1
NEW 048011-26186	3' x 5'	Concrete (Lt. Grey)	1
NEW 048011-26187	3' x 5'	Dove (Brown)	1
NEW 048011-26445	3' x 5'	Slate (Grey)	1
NEW 048011-26446	3' x 5'	Seagrey	1
NEW 048011-26447	3' x 5'	Cabernet	1
NEW 048011-26448	3' x 5'	Chestnut (Dk. Brown)	1
NEW 048011-26449	3' x 5'	Blue	1
NEW 048011-26450	3' x 5'	Silver	1
NEW 048011-26451	3' x 5'	Forest	1
NEW 048011-29566	3' x 10'	W/ Nosing Slate	1
NEW 048011-26239	3' x 20'	Slate (Grey)	1
NEW 048011-26240	3' x 20'	Dove (Brown)	1
NEW 048011-26242	3' x 20'	Forest	1
NEW 048011-26243	3' x 20'	Blue	1
NEW 048011-26246	3' x 20'	Ebony	1
NEW 048011-17788	4' x 6'	Red	1
NEW 048011-17790	4' x 6'	Ebony	1
NEW 048011-26188	4' x 6'	Concrete (Lt. Grey)	1
NEW 048011-26189	4' x 6'	Dove (Brown)	1
NEW 048011-26452	4' x 6'	Slate (Grey)	1
NEW 048011-26453	4' x 6'	Cabernet	1
NEW 048011-26454	4' x 6'	Seagrey	1
NEW 048011-26455	4' x 6'	Chestnut (Dk. Brown)	1
NEW 048011-26456	4' x 6'	Blue	1
NEW 048011-26457	4' x 6'	Silver	1
NEW 048011-26458	4' x 6'	Forest	1
NEW 048011-26269	4' x 20'	Ebony	1
NEW 048011-26272	4' x 20'	Blue	1
NEW 048011-26273	4' x 20'	Forest	1
NEW 048011-26275	4' x 20'	Dove (Brown)	1
NEW 048011-26276	4' x 20'	Slate (Grey)	1

Part Number	Size	Color	Each Per Case
NEW 048011-17635	3' x 20'	Spruce	1
NEW 048011-17636	3' x 20'	Blueberry	1

## 3M™ Safety-Walk™ Matting Wet Area Matting 3200

Also known as 3M™ Entrap™ Wet Area Matting; 3M™ Safety-Walk™ Wet Area Matting 3200 is ideal for pool/whirlpool areas, locker rooms, shower areas and around saunas. The open, vinyl Z-web design allows liquids and small debris to fall through, helping to reduce slips and falls. The matting has an antimicrobial coating providing resistance to mildew, fungus and odors in the mat. The open, Z-web construction provides a barefoot slip-resistant surface for wet areas. The matting's surface spacing and design provides uniform foot support.

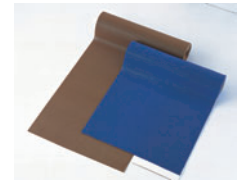

Part Number	Size	Color	Each Per Case
NEW 048011-13722	3' x 20'	Blue	1
NEW 048011-13723	3' x 20'	Wheat	1
NEW 048011-16107	3' x 10'	Blue	1
NEW 048011-16108	3' x 10'	Wheat	1

# Floor and Deck Matting

## 3M™ Nomad™ Carpet Matting 4000

3M™ Nomad™ Carpet Matting 4000 is a ribbed product that removes dirt and water from foot traffic. This product is suitable for entryways of low traffic facilities.



## 3M™ Enhance™ Matting 850

Also known as 3M™ Nomad™ Carpet Matting 8850; 3M™ Enhance™ Matting 850 features a patented dual-fiber design: large, crush-resistant polypropylene fibers that scrape, remove and hide loose dirt; and small nylon fibers that wick away water from foot and wheeled traffic for heavy traffic entryways.

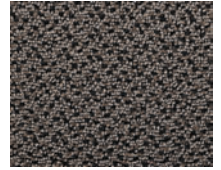

Part Number	Size	Color	Each Per Case	Part Number	Size	Color	Each Per Case
NEW 048011-23748	2' x 3'	Charcoal	6	NEW 048011-20639	2' x 3'	Checkers (Gr/Rd)	6
NEW 048011-23749	2' x 3'	Brown	6	NEW 048011-20640	2' x 3'	Dove (Brown)	6
NEW 048011-23750	2' x 3'	Lt. Grey	6	NEW 048011-20641	2' x 3'	Slate (Grey)	6
NEW 048011-23763	2' x 3'	Hunter Green	6	NEW 048011-20642	2' x 3'	Ebony	6
NEW 048011-23764	2' x 3'	Cranberry	6	NEW 048011-23413	2' x 3'	Blueberry	6
NEW 048011-23322	3' x 5'	Hunter Green	1	NEW 048011-23414	2' x 3'	Burgundy	6
NEW 048011-23766	3' x 5'	Cranberry	1	NEW 048011-23415	2' x 3'	Spruce	6
NEW 048011-23767	3' x 5'	Charcoal	1	NEW 048011-20529	3' x 5'	Checkers (Gr/Rd)	1
NEW 048011-23768	3' x 5'	Brown	1	NEW 048011-20544	3' x 5'	Dove (Brown)	1
NEW 048011-23769	3' x 5'	Lt. Grey	1	NEW 048011-20559	3' x 5'	Slate (Grey)	1
NEW 048011-23770	3' x 10'	Hunter Green	1	NEW 048011-20583	3' x 5'	Ebony	1
NEW 048011-23771	3' x 10'	Charcoal	1	NEW 048011-23416	3' x 5'	Spruce	1
NEW 048011-23772	3' x 10'	Cranberry	1	NEW 048011-23417	3' x 5'	Blueberry	1
NEW 048011-23773	3' x 10'	Brown	1	NEW 048011-23418	3' x 5'	Burgundy	1
NEW 048011-23774	3' x 10'	Lt. Grey	1	NEW 048011-20531	3' x 10'	Checkers (Gr/Rd)	1
NEW 048011-23788	4' x 6'	Cranberry	1	NEW 048011-20546	3' x 10'	Dove (Brown)	1
NEW 048011-23789	4' x 6'	Hunter Green	1	NEW 048011-20561	3' x 10'	Slate (Grey)	1
NEW 048011-23790	4' x 6'	Charcoal	1	NEW 048011-20585	3' x 10'	Ebony	1
NEW 048011-23791	4' x 6'	Brown	1	NEW 048011-23419	3' x 10'	Burgundy	1
NEW 048011-23793	4' x 6'	Lt. Grey	1	NEW 048011-23420	3' x 10'	Spruce	1
NEW 048011-23794	4' x 10'	Hunter Green	1	NEW 048011-23421	3' x 10'	Blueberry	1
NEW 048011-23795	4' x 10'	Cranberry	1	NEW 048011-20530	4' x 6'	Checkers (Gr/Rd)	1
NEW 048011-23796	4' x 10'	Charcoal	1	NEW 048011-20545	4' x 6'	Dove (Brown)	1
NEW 048011-23797	4' x 10'	Brown	1	NEW 048011-20560	4' x 6'	Slate (Grey)	1
NEW 048011-23798	4' x 10'	Lt. Grey	1	NEW 048011-20584	4' x 6'	Ebony	1
				NEW 048011-23430	4' x 6'	Spruce	1
				NEW 048011-23431	4' x 6'	Burgundy	1
				NEW 048011-23432	4' x 6'	Blueberry	1
				NEW 048011-23435	4' x 8'	Spruce	1
				NEW 048011-20535	4' x 8'	Checkers (Gr/Rd)	1
				NEW 048011-20550	4' x 8'	Dove (Brown)	1
				NEW 048011-20565	4' x 8'	Slate (Grey)	1
				NEW 048011-20589	4' x 8'	Ebony	1
				NEW 048011-23433	4' x 8'	Blueberry	1
				NEW 048011-23434	4' x 8'	Burgundy	1
				NEW 048011-20536	4' x 10'	Checkers (Gr/Rd)	1
				NEW 048011-20551	4' x 10'	Dove (Brown)	1
				NEW 048011-20590	4' x 10'	Ebony	1
				NEW 048011-23436	4' x 10'	Spruce	1
				NEW 048011-23437	4' x 10'	Burgundy	1
				NEW 048011-23438	4' x 10'	Blueberry	1
				NEW 048011-20566	4' x 10'	Slate (Grey)	1
				NEW 048011-20540	6' x 10'	Checkers (Gr/Rd)	1
				NEW 048011-20555	6' x 10'	Dove (Brown)	1
				NEW 048011-20570	6' x 10'	Slate (Grey)	1
				NEW 048011-20594	6' x 10'	Ebony	1
				NEW 048011-23387	6' x 10'	Blueberry	1
				NEW 048011-23448	6' x 10'	Spruce	1
				NEW 048011-23449	6' x 10'	Burgundy	1



# Floor and Deck Matting Accessories

## 3M™ Matting Seaming Tape Kit

Kit consists of: 10' Vinyl and 1 Tube Adhesive

Part Number	Color	Kits Per Case
048011- <b>08148</b>	Brown	10

## 3M™ Matting Seaming Tape

100' Roll

Part Number	Color	Rolls Per Case
048011- <b>09457</b>	Brown	5

## 3M™ Edging Adhesive

Adhesive – 3 oz. Tubes



Part Number	Tubes Per Case
048011- <b>08554</b>	12

# 3M™ Scotchlite™ Reflective Products

## 3M™ Scotchlite™ Reflective Safety Tape

The 3M™ Scotchlite™ Reflective Tapes and Reflective Kits are composed of a highly flexible, durable, adhesive coated sheeting designed for areas that require bright night-time light reflectivity needed to increase safety. Examples include: trailers, driveways, mailboxes, bicycles, farm equipment, RVs and watercraft. In addition, they can be used at the marina or boat docking location to increase awareness and safety. For best results the surfaces should be smooth and clean. The 580 series tape will work on metal, glass, fiberglass, wood, and painted surfaces. Note: For life saving equipment such as life vests, jackets, liferings, lifefloats, lifeboats, and liferafts, 3M™ Scotchlite™ Reflective Sheeting High Intensity SOLAS Grade Series 3150A is recommended.



Part Number	Color	Size	Packs Per Case
051131- <b>03455</b>	Silver	1" x 36"	24
051131- <b>03458</b>	Red	1" x 36"	24
051131- <b>03456</b>	Silver	2" x 36"	24
051131- <b>03459</b>	Red	2" x 36"	24
051131- <b>03457</b>	Kit/Silver	4" x 4.75"	24
051131- <b>03460</b>	Kit/Red	4" x 4.75"	24

## 3M™ Scotchlite™ High Visibility Reflective Safety Strips

3M™ Scotchlite™ High Visibility Reflective Safety Strips consist of Series 980 Retroreflective Prismatic Sheeting. This 3M™ Scotchlite™ Diamond Grade Conspicuity Sheeting is a highly reflective prismatic sheeting that is backed with a pressure-sensitive adhesive and clear poly liner. Applied to properly prepared substrates, Diamond Grade sheeting should provide seven-year field performance. The 18" strips incorporate an 11" red/7" white pattern. The 12" strips have a 6" red/6" white configuration. These strips are easy to apply and have durable presealed edges. They are non-metallic to prevent corrosion. Uses include boat trailers, docks, watercraft, ATVs, and snowmobiles. Approved and certified for the Department of Transportation.



Part Number	Color	Size	Packs Per Case
051131- <b>03461</b>	Alternating Red/White	2" x 18" (2 Strips)	24
051131- <b>03462</b>	Alternating Red/White	2" x 18" (4 Strips)	24
051131- <b>03463</b>	Alternating Red/White	2" x 12" (2 Strips)	24
051131- <b>03464</b>	Alternating Red/White	2" x 12" (4 Strips)	24

# 3M™ Scotchlite™ Reflective Products

## 3M™ Scotchlite™ Reflective Sheeting High Intensity SOLAS Grade 3150A

3M™ Scotchlite™ High Intensity SOLAS (Safety Of Life At Sea) Grade Reflective Sheeting 3150A is a flexible, encapsulated lens, highly-reflective material, pre-coated with an improved aggressive pressure-sensitive adhesive. The sheeting remains highly reflective when totally wet as well as when viewed at wide entrance angles. The reflective sheeting is designed for nighttime visibility of life support equipment. It conforms well for application on flexible or rigid substrates used in life support equipment (life rafts, jackets, vests, etc). The sheeting has been successfully applied to most nylon, cotton, rubber and laminated or coated combinations of these materials normally used in the manufacture of life support equipment. Material is Coast Guard and IMO Certified.



Part Number	Size	Rolls Per Case
NEW 051131- <b>88619*</b>	50.8mm x 50m	1
NEW 051131- <b>88622**</b>	76.2mm x 50m	4
NEW 051131- <b>88624***</b>	101.6mm x 50m	3

\* Metric Replacement for PN67119

\*\* Metric Replacement for PN67480

\*\*\* Metric Replacement for PN67479

## 3M™ Scotchlite™ Diamond Grade Conspicuity Sheeting Series 981

3M™ Scotchlite™ Diamond Grade Conspicuity Sheeting Series 981 responds to the need for improved safety with 2" wide rolls of an alternating red and white (silver) reflective tape. Excellent for boats, trailers, docks, etc.



Part Number	Roll Size	Color	Rolls Per Case
051138- <b>67533</b>	2" x 150'	Red 11", White 7"	1
051138- <b>67535</b>	2" x 150'	Red 6", White 6"	1
051138- <b>67537</b>	2" x 150'	White	1
051138- <b>67817</b>	2" x 150'	Yellow	1

## 3M™ Scotchcal™ Luminous Film 6900

3M™ Scotchcal™ Luminous Film 6900 is the ideal interior safety, emergency exit, and evacuation marking for ships, passenger vessels, airplanes, trains, and buildings. This new luminous film meets and exceeds specification ASTM 2072 for luminosity. Luminous film 6900 may be used to mark exits, doorways, stairways, hatchways, floors and ceilings – any surface that needs to direct or inform people during emergency or lights-out conditions. Luminous film 6900 is easy to apply and is warranted for 7 years.



Part Number	Roll Size	Rolls Per Case
NEW 051135- <b>27725</b>	1" x 10 yds.	6
NEW 051135- <b>27726</b>	2" x 10 yds.	3
NEW 051135- <b>27727</b>	3" x 10 yds.	2

## 3M™ Marine Scotchlite™ Reflective Material (SOLAS)

3M™ Scotchlite™ High Intensity SOLAS (Safety Of Life At Sea) Grade Reflective Material is a flexible, encapsulated lens, high-reflective material, pre-coated with an improved aggressive pressure-sensitive adhesive. The sheeting remains highly reflective when totally wet as well as when viewed at wide entrance angles. The reflective sheeting is designed for nighttime visibility of life support equipment. It conforms well for application on flexible or rigid substrates used in life support equipment (life rafts, jackets, vests, etc.). The sheeting has been successfully applied to most nylon, cotton, rubber and laminated or coated combinations of these materials normally used in the manufacture of life support equipment. Material is Coast Guard and IMO Certified. Retail packaged; twelve 2" x 4" strips per package. Six packages per case.



Part Number	Description	Packs Per Case
NEW 051131- <b>88418</b>	12 strips per package	6

# 3M™ Vangard™ Lenses

## 3M™ Vangard™ Lenses

3M™ Vangard™ wide-angle window lenses reduce the chance of squeeze accidents caused by blind spots. Excellent for use when towing trailered boats. Made of thin flexible plastic, these lenses provide an extreme wide angle view. Obstacles can be seen, right down to the pavement; areas rear view mirrors miss. 3M™ Vangard™ Lenses are easily applied and removed by hand using water only and they won't damage the glass.



Part Number	Description	Size	Each Per Case
051131-07950	3M™ Vangard™ Lenses	8" x 10"	12
051131-07951	3M™ Super Vangard™ Lenses	11" x 14"	12
051131-07952	3M™ Vangard™ 2 Lenses	6" x 8"	12

# Thinsulate™ Sound & Thermal Insulation

## Thinsulate™ Marine Insulation

Thinsulate™ Marine Insulation is a non-woven mat that has excellent sound-absorbing properties useful in many marine interior applications. It is compressible, non-linting, lightweight, hydrophobic (does not absorb moisture) and it can be easily die-cut.

	Product	Covering	Roll Width	Roll Length	Roll Area	Part Number
<b>MA4700 Series</b>  <b>Thickness:</b> 3/4" – 1" (19 – 26mm)  <b>Weight:</b> 1.4oz/ft <sup>2</sup> (417g/m <sup>2</sup> )  <b>For filling gaps:</b> 1/2" – 1" (13 – 26mm)  R value 4 at 26mm thickness	MA4700	None	30" (76cm)	270' (82m)	675 ft <sup>2</sup> (63m <sup>2</sup> )	76766
	MA4700	None	60" (1.52m)	90' (27m)	450 ft <sup>2</sup> (42m <sup>2</sup> )	76767
	MA4700	None	60" (1.52m)	270' (82m)	1350 ft <sup>2</sup> (125m <sup>2</sup> )	76650
	MA4710	Black	30" (76cm)	375' (114m)	937 ft <sup>2</sup> (87m <sup>2</sup> )	76768
	MA4710	Black	60" (1.52m)	90' (27m)	450 ft <sup>2</sup> (42m <sup>2</sup> )	76769
	MA4710	Black	60" (1.52m)	375' (114m)	1875 ft <sup>2</sup> (174m <sup>2</sup> )	76631
	MA4720	White	30" (76cm)	375' (114m)	937 ft <sup>2</sup> (87m <sup>2</sup> )	76770
	MA4720	White	60" (1.52m)	90' (27m)	450 ft <sup>2</sup> (42m <sup>2</sup> )	76771
	MA4720	White	60" (1.52m)	375' (114m)	1875 ft <sup>2</sup> (174m <sup>2</sup> )	76653
	MA4720M	Metal Film	25" (63cm)	225' (69m)	469 ft <sup>2</sup> (44m <sup>2</sup> )	76840
	MA4720M	Metal Film	50" (1.27m)	90' (27m)	375 ft <sup>2</sup> (35m <sup>2</sup> )	76841
	MA4720M	Metal Film	50" (1.27m)	225' (69m)	937 ft <sup>2</sup> (87m <sup>2</sup> )	76842
	<b>MA6700 Series</b>  <b>Thickness:</b> 1-1/2" – 2" (38 – 51mm)  <b>Weight:</b> 2.0 oz/ft <sup>2</sup> (617g/m <sup>2</sup> )  <b>For filling gaps:</b> 1" – 2" (25 – 51mm)  R value 6 at 44mm thickness	MA6710	Black	30" (76cm)	225' (69m)	562 ft <sup>2</sup> (52m <sup>2</sup> )
MA6710		Black	60" (1.52m)	90' (27m)	450 ft <sup>2</sup> (42m <sup>2</sup> )	76775
MA6710		Black	60" (1.52m)	225' (69m)	1125 ft <sup>2</sup> (104m <sup>2</sup> )	76633
MA6720		White	30" (76cm)	225' (69m)	562 ft <sup>2</sup> (52m <sup>2</sup> )	76776
MA6720		White	60" (1.52m)	90' (27m)	450 ft <sup>2</sup> (42m <sup>2</sup> )	76777
MA6720		White	60" (1.52m)	225' (69m)	1125 ft <sup>2</sup> (104m <sup>2</sup> )	76634
MA6720M		Metal Film	25" (63cm)	150' (46m)	312 ft <sup>2</sup> (29m <sup>2</sup> )	76843
MA6720M		Metal Film	50" (1.27m)	90' (27m)	375 ft <sup>2</sup> (35m <sup>2</sup> )	76844
MA6720M		Metal Film	50" (1.27m)	150' (46m)	625 ft <sup>2</sup> (58m <sup>2</sup> )	76845

# Electrical Products

## Scotch® Super 33 Plus Vinyl Plastic Electrical Tape

A premium grade all-weather tape; has excellent resistance to flame, abrasion, moisture, alkalis, solvents, oil and many acids. Gives full electrical and mechanical protection.



Part Number	Size	Rolls Per Box	Boxes Per Case
054007-06130	3/4" x 20 ft.	10	10
054007-10075	3/4" x 44 ft.	10	10
054007-06132	3/4" x 66 ft.	10	10
054007-06133	3/4" x 52 ft.	10	10
054007-10216	3/4" x 66 ft. D	10	10

D = Cutter Dispenser

## Scotch® Super 88 Vinyl Plastic Tape

An 8.5 mil vinyl tape recommended for cold weather applications when conventional plastic tapes become brittle and stiff. Extra thickness provides increased abrasion resistance. U.L. listed.



Part Number	Size	Rolls Per Box	Boxes Per Case
054007-10307	3/4" x 44 ft.	10	10
054007-06143	3/4" x 66 ft.	10	10

## Highland™ Vinyl Electrical Tape

An economically priced tape that is 7 mils thick, tough and stretchy. Each roll cellophane wrapped. U.L. listed.



Part Number	Size	Rolls Per Sleeve	Boxes Per Sleeves
054007-16720	3/4" x 66 ft.	10	10

## Scotch® 2200 Vinyl Mastic Pads

Scotch® 2200 Vinyl Mastic Pads are self-fusing, rubber-based insulating compounds laminated to a flexible, all-weather grade PVC backing. Pads are resistant to abrasion, moisture, alkalis, acid, copper corrosion, ultraviolet (U.V.) and varying weather conditions. Another option for insulating wire connections against moisture and corrosion.



Part Number	Size	Pads Per Box	Pads Per Case
054007-11008	3-1/4" x 4-1/2"	10	50
054007-21296	6-1/2" x 4-1/2"	10	50

## Scotch® 2210 Vinyl Mastic Rolls

Scotch® 2210 Vinyl Mastic Rolls are self-fusing, rubber-based insulating compounds laminated to a flexible, all-weather grade PVC backing. Rolls are resistant to abrasion, moisture, alkalis, acid, copper corrosion, ultraviolet (U.V.) and varying weather conditions. Another option for insulating wire connections against moisture and corrosion.



Part Number	Size	Rolls Per Box	Rolls Per Case
054007-11222	4" x 10'	1	10

## Scotch® 2242 Linerless Splicing Compound

Scotch® 2242 Linerless Splicing Compound is designed to offer the ultimate in protection of electrical wiring and connectors from shorts and failures caused by moisture and corrosion. It is self-bonding, moisture resistant, weather resistant – will not crack or embrittle in ultraviolet light or cold temperature.



Part Number	Size	Rolls Per Case
051131-06165	3/4" x 15 ft.	24

## Scotch® 2228 Rubber Mastic Tape

Scotch® 2228 Rubber Mastic Tape is made of a self-fusing, rubber-based insulating compound. Scotch® 2228 is laminated to an Ethylene Propylene Rubber (EPR) backing that offers moisture resistance and an ability to easily stretch the tape.



Part Number	Thickness	Roll Size	Rolls Per Case
054007-50727	65 mils.	1" x 10'	12
054007-09656	65 mils.	2" x 10'	10

## Scotch® 35 Vinyl Electrical Tape — for Color Coding

This tape is the electrician's safety tool in a roll. Use it for phase identification, marking of motor leads and piping systems and for outlining safety areas. It is available in assorted colors. Also used as a rigging tape.



Part Number	Color	Size	Rolls Per Case
054007-10810	Red	3/4" x 66 ft.	10
054007-10828	White	3/4" x 66 ft.	10
054007-10836	Blue	3/4" x 66 ft.	10
054007-10851	Green	3/4" x 66 ft.	10

## Tartan™ Vinyl Electrical Tape

Tartan™ Vinyl Electrical Tape is an American made general purpose electrical insulating tape. This tape is economical and durable with excellent resistance to a wide range of contaminants and weather conditions.



Part Number	Size	Rolls Per Case
49656	3/4" x 60'	100

# Electrical Products

## 3M™ ScotchCode™ Wire Marker Tape Dispenser

Provides a fast, convenient system for marking wire, cable, or vacuum hoses. Using the special end loop, it can be hooked on belt or tool pouch. The small size also makes it easy to carry in a pocket or tool box – always at hand. The 10 refillable compartments allow you to choose the exact number or color combinations you need. Numbered dispenser filled with numbers 0 thru 9, colored dispenser filled with assorted colors.



Part Number	Description	Each Per Case
<b>Filled Number Dispenser</b>		
054007-49518	Dispenser	10
<b>Filled Color Coded Dispenser</b>		
054007-49517	Dispenser	10
<b>Empty Dispenser (Either Color or Numbers)</b>		
054007-49519	Dispenser	10

## 3M™ Scotchlok™ TH-450 Scissors Style Crimping Tool

The Scotchlok™ TH-450 is 3M's most versatile and heavy-duty tool. Made of high-strength-heat-treated carbon steel, the TH-450 is lightweight without sacrificing strength. It handles a variety of terminal and conductor styles, including flags, closed-end connectors, crimp sleeves and standard parts, both insulated and non-insulated. With a range of 26-6 AWG wire size, connections are U.L. approved when the crimping process is completed and the tool releases.



Part Number	Wire Range	Tools Per Case
054007-13760	26-6	10

## 3M™ ScotchCode™ Wire Marker Tape

This tape is a 5.5 mil reinforced, flame-retardant epoxy film tape with an acrylic, high tack pressure-sensitive adhesive. Tape resists abrasion, oil and water and adheres to clean neoprene, Hypalon®, nylons and PVC insulation materials. Non-smear identification for all marking jobs. Available in numbers 0 thru 9 and the 10 assorted colors listed below. Hypalon® is a registered trademark of DuPont Dow Elastomers.



### Part Number Description Packs Per Case

054007-09368	0 thru 9	1
--------------	----------	---

### Part Number Description Rolls Per Case

054007-09369	0	10
054007-09370	1	10
054007-09371	2	10
054007-09372	3	10
054007-09373	4	10
054007-09374	5	10
054007-09375	6	10
054007-09376	7	10
054007-09377	8	10
054007-09378	9	10

### Part Number Description Packs Per Case

054007-09404	Assortment	1
--------------	------------	---

### Part Number Description Rolls Per Case

054007-09423	Black	10
054007-09424	Blue	10
054007-09425	Brown	10
054007-09426	Green	10
054007-09427	Gray	10
054007-09428	Orange	10
054007-09429	Red	10
054007-09430	White	10
054007-09431	Yellow	10
054007-09458	Violet	10

# Electrical Products

## 3M™ EPS-300 Heat Shrink Tubing

3M™ EPS-300 Heat Shrink Tubing offers marine electrical and environmental protection for electronic components, wire splices, wire bundles, and harness breakouts. 3M™ EPS-300 is a superb insulator that also functions as a strain relief and an environmental seal.



Part Number	Size	Color	Pieces Per Box	Boxes Per Case
051135- <b>36875</b>	3/16" x 4'	Black	12	1
051135- <b>36876</b>	1/4" x 4'	Black	12	1
051135- <b>36877</b>	3/8" x 4'	Black	12	1
051135- <b>36878</b>	1/2" x 4'	Black	12	1
051135- <b>36879</b>	3/4" x 4'	Black	5	1
051135- <b>36880</b>	1" x 4'	Black	5	1
051135- <b>36881</b>	1-1/2" x 4'	Black	5	1

## 3M™ EPS-300 Heat Shrink Tubing Kit

The 3M™ EPS-300 Heat Shrink Tubing Kit is an assortment of adhesive-lined, flexible, polyolefin heat shrink tubing. Each box is 7" x 11" x 2-1/2" of rugged translucent plastic with product and installation information on the cover. Refill packs are available for the individual components. The kit contains the following 42 pieces that are listed by expanded diameter:



Description	Size	# of 6" Pieces
EPS-300 Red	1/2" (12.70 mm)	12
EPS-300 Black	1/2" (12.70 mm)	12
EPS-300 Red	3/4" (19.05 mm)	6
EPS-300 Black	3/4" (19.05 mm)	6
EPS-300 Red	1" (25.40 mm)	3
EPS-300 Black	1" (25.40 mm)	3

Part Number	Kits Per Case
051135- <b>38444</b>	5

## 3M™ Kynar® Heat Shrink Tubing

A higher performance tubing good for engine compartment applications. This tubing has outstanding abrasion resistance, is inherently flame retardant and highly resistant to most industrial fuels, chemicals and solvents. The shrink ratio is 2:1 and the color is clear. Kynar® is a registered trademark of Elf Atochem North America, Inc.



Part Number	Size	Color	Pieces Per Box	Boxes Per Case
051135- <b>36886</b>	3/64" x 4'	Clear	25	1
051135- <b>36887</b>	1/16" x 4'	Clear	25	1
051135- <b>36888</b>	3/32" x 4'	Clear	25	1
051135- <b>36889</b>	1/8" x 4'	Clear	25	1
051135- <b>36890</b>	3/16" x 4'	Clear	12	1
051135- <b>36891</b>	1/4" x 4'	Clear	12	1
051135- <b>36892</b>	3/8" x 4'	Clear	12	1
051135- <b>36893</b>	1/2" x 4'	Clear	5	1
051135- <b>36894</b>	3/4" x 4'	Clear	5	1

## 3M™ FP301 Heat Shrink Tubing Refill Packs



Part Number	Refill Pack Contents	Packs Per Case
051135- <b>36618</b>	3/32" (2,36mm) 35 pieces, 7 colors	10
051135- <b>36619</b>	1/8" (3,18 mm) 28 pieces, 7 colors	10
051135- <b>36620</b>	3/16" (4,75 mm) 21 pieces, 7 colors	10
051135- <b>36621</b>	1/4" (6,35 mm) 21 pieces, 7 colors	10
051135- <b>36622</b>	3/8" (9,53 mm) 14 pieces, 7 colors	10
051135- <b>36623</b>	1/2" (12,70 mm) 14 pieces, 7 colors	10

# Electrical Products

## 3M™ Cold Shrink Tubing

8420 & 8430 Series — EPDM Rubber  
8440 Series — Silicone Rubber



3M™ Cold Shrink Tubing is open-ended rubber sleeves which are factory expanded and assembled onto removable plastic cores. The core is removed after the tube has been positioned for installation over an inline connection, coupling cable or termination, allowing the tube to shrink and form a water-resistant seal. With 3M™ Cold Shrink Tubing you get a water-resistant seal without heat, torches or adhesives. Simply unwind the core to install, it's that simple.

Part Number	Catalog Number	Description/Insulation Range	Tube Length	Each Per Case
054007-42146	8423-6	Connector Insulators (EPDM) .31 – .56	6"	10
054007-42390	8424-8	Connector Insulators (EPDM) .10 – .82	8"	10
054007-42391	8425-8	Connector Insulators (EPDM) .40 – .82	8"	10
054007-34457	8426-9	Connector Insulators (EPDM) .55 – 1.18	9"	10
054007-34458	8426-11	Connector Insulators (EPDM) .55 – 1.18	11"	10
054007-09915	8427-6	Connector Insulators (EPDM) .67 – 1.38	6"	10
054007-34459	8427-12	Connector Insulators (EPDM) .67 – 1.38	12"	10
054007-34460	8427-16	Connector Insulators (EPDM) .67 – 1.38	16"	10
054007-09916	8428-6	Connector Insulators (EPDM) .95 – 1.94	6"	10
054007-09056	8428-12	Connector Insulators (EPDM) .95 – 1.94	12"	10
054007-34461	8428-18	Connector Insulators (EPDM) .95 – 1.94	18"	10
054007-09917	8429-6	Connector Insulators (EPDM) 1.27 – 2.67	6"	10
054007-09931	8429-9	Connector Insulators (EPDM) 1.27 – 2.67	9"	10
054007-42389	8429-12	Connector Insulators (EPDM) 1.27 – 2.67	12"	10
054007-34462	8429-18	Connector Insulators (EPDM) 1.27 – 2.67	18"	10
054007-42147	8430-9	Connector Insulators (EPDM) 1.68 – 3.69	9"	10
054007-42388	8430-18	Connector Insulators (EPDM) 1.68 – 3.69	18"	10

## 3M™ Cold Shrink Tubing (cont.)

Part Number	Catalog Number	Description/Insulation Range	Tube Length	Each Per Case
054007-09485	8443-2	Silicone Insulators .27 – .56	2"	12
054007-09482	8443-6.5	Silicone Insulators .27 – .56	6.5"	12
054007-09486	8445-2.5	Silicone Insulators .35 – .72	2.5"	12
054007-09483	8445-7.5	Silicone Insulators .35 – .72	7.5"	12
054007-09487	8447-3.2	Silicone Insulators .48 – .95	3.2"	12
054007-09484	8447-8	Silicone Insulators .48 – .95	8"	12

## Scotch® Electrical Moisture Sealant Compound

Provides a quick and easy method of moisture proofing electrical connections. The master forms a moisture tight seal around connections and the tough elastic vinyl backing provides additional protection against vibration. Also can be used for wire repair, sealing lights and protecting terminal blocks. Designed for moisture sealing of electrical connections up to 600 volts.



Part Number	Size	Each Per Box	Boxes Per Case
054007-06147	2-1/2" x 10 ft.	1	10

## Scotch® Electrical Moisture Sealant Pads

Scotch™ Electrical Moisture Sealant is now available in 2-1/2" x 2-1/2" patches. These patches can be used in place of tape to give connections all season/all weather protection and applies in less time. The tough vinyl backing prevents abrasion and protects against all common marine elements. In addition to providing a moisture-proof barrier for connections, these patches can be used for wire repair, sealing lights and protecting terminal blocks. Designed for moisture sealing of electrical connections up to 600 volts.

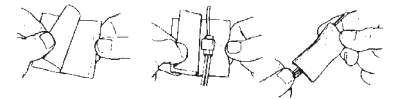

Part Number	Size	Patches Per Box	Boxes Per Case
054007-06149	2-1/2" x 2-1/2"	25	10



# Electrical Products

## 3M™ Scotchkote™ Electrical Coating

This fast-drying coating provides extra protection to splices where moisture, oil and corrosive conditions can cause problems. Helps prevent cable and connector damage due to corrosive vapors from battery outgassing.



Part Number	Container Size	Cans Per Case
054007-14853	15 fl. oz. Can	10

## 3M™ Scotchlok™ Bullet Receptacle Connector

Designed to allow quick connect, quick disconnect of the electrical system. This connector attaches quickly and easily with no wire stripping to any 14,16 or 18 gauge copper wire operating at 48 volts or below. With no special tools except a pair of pliers the receptacle connector attaches to the wiring and connects to most standard bullet connectors. Mates with 3M™ Scotchlok™ Snap Plug (Bullet) Terminal (PN06108) and all standard .157" bullet terminals.

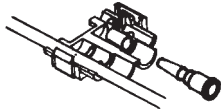

Part Number	Connector Number	Connectors Per Box	Boxes Per Case
054007-06106	901	50	10

## 3M™ Scotchlok™ Snap Plug (Bullet) Terminal

A vinyl insulated bullet terminal which can be permanently attached to any 14,16 gauge copper wire. This male snap plug is designed to be mated with our type 901 3M™ Scotchlok™ Bullet Receptacle Connector (PN06106).



Part Number	Connector Number	Connectors Per Box	Boxes Per Case
054007-06108	C-41-1101	100	500

## 3M™ Scotchlok™ 314 Electrical Connector

3M™ Scotchlok™ 314 Electrical Connectors contain a special compound inside the connector to protect against corrosion in damp conditions. Handles 22-14 AWG solid or stranded wire. Wires are held with a double "U" element to provide a much stronger connection while reducing electrical resistance.



Part Number	Connectors Per Box	Boxes Per Case
-------------	--------------------	----------------

### Boxed

054007-09230	50	10
--------------	----	----

Part Number	Connectors Per Bag	Bags Per Case
-------------	--------------------	---------------

### Bulk

054007-09231	1000	1
--------------	------	---

## 3M™ Scotchlok™ 804 Instant Moisture Resistant Auto-Electric Connectors

3M™ Scotchlok™ 804 Instant Moisture Resistant Auto-Electric Connectors make inline, pigtail and tap splices on solid or stranded wire with no wire cutting or stripping. With a standard pair of pliers any boat or trailer wiring job can be installed faster and easier with less training than any method previously used. The 804 Connector is listed by Underwriters Laboratories. Wire range Tap-run is 14 to 14, 16 to 16 and 18 to 18. Color: Blue

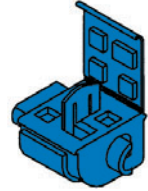

Part Number	Connector Number	Connectors Per Box/Bag	Boxes/Bags Per Case
054007-06134	804 Boxed	25	10
054007-06135	804 Bulk	500	10

## 3M™ Scotchlok™ Instant Electric Connectors

3M™ Scotchlok™ Instant Electric Connectors make inline, pigtail and tap splices on solid or standard wire with no stripping. With a standard pair of pliers any wiring job can be installed easier and faster.



Part Number	Connector Number	Color	Wire Range Tap Run
054007-06118	564	White	14 14 16 to 16 18 18
054007-06119 054007-06120	902*	Brown	12 10 16 to 12 18
054007-06122 054007-06123	903*	Yellow	10 10 12 to 12
054007-06126 054007-06127	801*	Blue	14 14 16 to 16 18 18
054007-06128 054007-06129	905*	Red	14 18 to 16 22 18

\* These connectors are listed by Underwriter's Laboratory

Part Number	Connector Number	Connectors Per Box	Boxes Per Case
<b>Boxed</b>			
054007-06119	902	50	10
054007-06122	903	50	10
054007-06126	801	50	10
054007-06128	905	50	10

Part Number	Connector Number	Connectors Per Bag	Connectors Per Case
<b>Bulk</b>			
054007-06118	564	500	5000
054007-06120	902	1000	1000
054007-06123	903	1000	1000
054007-06127	801	500	5000
054007-06129	905	500	5000

# Electrical Products

## 3M™ Empty Scotchlok™ Terminal Boxes

The empty 3M™ Scotchlok™ terminal box is a red metal 17 slot or 24 slot box to hold your 3M™ Scotchlok™ terminals.



Part Number	Dimensions/Slots	Each Per Case
054007-11900	13.5" x 9.5" x 2" 17 Slot	6
054007-06161	18" x 12" x 3" 24 Slot	1

## 3M™ Scotchlok™ Electrical Connectors

For sure, quick easy splicing of solid or stranded wires. Packed 10 boxes per case.



Part Number	Type	Wire Range	Connectors Per Box	Connectors Per Case
054007-20041	"Y"	18-12	100	1000
054007-20058	"R"	16-10	100	1000
054007-42033	"B"	12-6	50	1000
054007-21346	"G"	14-8	100	1000

## 3M™ Scotchlok™ #558 Self-Stripping Electrical Tap Connectors

The 3M™ Scotchlok™ #558 Connector is specially designed for small wire gauges. This U.L. listed connector permits fast and effective tap wire connections on 22-16 gauge standard or solid wire.

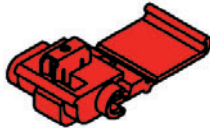

Part Number	Connectors Per Box	Boxes Per Case
<b>Boxed</b>		
054007-14861	100	10
Part Number	Connectors Per Bag	Bags Per Case
<b>Bulk</b>		
054007-14879	500	10

## 3M™ Scotchlok™ Fuse Holder

The 3M™ Scotchlok™ Fuse Holder is an inline fuse holder, designed to accommodate blade-type fuses. The fuse holder incorporates our patented self-stripping connector concept which simplifies installation by eliminating the need for supplemental connectors, thus reducing installation costs.



Part Number	Product Number	Holders Per Box	Boxes Per Case
<b>Boxed</b>			
054007-06171	972	25	10
Part Number	Product Number	Holders Per Case	
<b>Bulk</b>			
054007-06172	972	1000	

## 3M™ Scotchlok™ Deluxe Terminal Assortment Kit

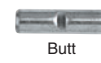

The 3M™ Scotchlok™ Deluxe Terminal Assortment Kit is a 24 compartment red and white metal box imprinted with "3M Scotchlok Terminals." The compartments will contain 737 of the 24 most popular insulated terminals as follows:

Part Number	Type	Number of Pieces
054007-11914	Ring	10
054007-11915	Ring	10
054007-11921	Ring	30
054007-11922	Ring	50
054007-11923	Ring	30
054007-11924	Ring	20
054007-11932	Ring	20
054007-11934	Ring	20
054007-11935	Ring	70
054007-11920	Butt	50
054007-11928	Butt	100
054007-11939	Butt	50
054007-11926	Fork	10
054007-11927	Fork	20
054007-11918	Fork	10
054007-06126	Tap	27
054007-22997	Male Q/Slide	50
054007-22880	Female Q/Slide	100
054007-06152	F/I Male Q/Slide	10
054007-11960	F/I Female Q/Slide	10
054007-11822	Male Q/Slide	10
054007-11820	Female Q/Slide	10
054007-11919	Fork	10
054007-11913	Ring	10
Part Number	Each Per Case	
054007-06160	1	

# Electrical Products

## 3M™ Scotchlok™ Boxed Terminals

V-Vinyl; N-Nylon; N-G-Nylon-G

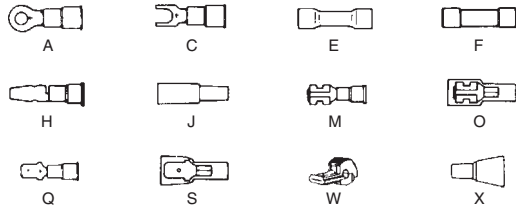

Part Number	Insulation	Wire Range	Stud Size	Each Per Box	Boxes Per Case	Ref. No.
<b>T-Tap</b>						
054007-06141	N	22-18	—	50	10	W
054007-06144	N	16-14	—	50	10	W
054007-06150	N	12-10	—	50	10	W
<b>Quick Slide (Fully Insulated)</b>						
054007-06152	N	16-14	—	100	5	S
054007-06153	N	12-10	—	50	10	S
054007-06154	N	22-18	—	100	5	S
054007-11959	N	22-18	—	100	5	O
054007-11960	N	16-14	—	100	5	O
054007-09991	N	12-10	—	50	10	O
<b>Assortment</b>						
054007-11000	—	—	—	1	5	—
<b>Bullet Receptacle</b>						
054007-11929	N	16-14	—	100	5	J
054007-11930	N	16-14	—	100	5	J
<b>Quick Slide</b>						
054007-11820	V	22-18	—	100	5	M
054007-11822	V	22-18	—	100	5	Q
054007-22880	V	16-14	—	100	5	M
054007-22997	V	16-14	—	100	5	Q
054007-09998	V	12-10	—	50	10	M
054007-23920	V	12-10	—	50	10	Q
<b>Ring</b>						
054007-11913	V	22-18	6	100	5	A
054007-11914	V	22-18	10	100	5	A
054007-11915	V	22-18	1/4"	100	5	A
054007-11921	V	16-14	6	100	5	A
054007-11922	V	16-14	10	100	5	A
054007-11923	V	16-14	1/4"	100	5	A
054007-11924	V	16-14	3/8"	100	5	A
054007-11932	V	12-10	10	50	10	A
054007-11934	V	12-10	1/4"	50	10	A
054007-11935	V	12-10	3/8"	50	10	A
054007-11936	V	12-10	1/2"	50	10	A
054007-11940	V	8	3/8"	25	10	A
054007-11943	V	6	3/8"	20	10	A
054007-15652	V	8	1/4"	25	10	A
054007-15660	V	6	1/4"	20	10	A

## 3M™ Scotchlok™ Boxed Terminals (cont.)

Part Number	Insulation	Wire Range	Stud Size	Each Per Box	Boxes Per Case	Ref. No.
<b>Block Spade</b>						
054007-11918	V	22-18	6	100	5	C
054007-11919	V	22-18	10	100	5	C
054007-11926	V	16-14	6	100	5	C
054007-11927	V	16-14	10	100	5	C
054007-11937	V	12-10	6	50	10	C
054007-11938	V	12-10	10	50	10	C
<b>Butt</b>						
054007-11920	V	22-18	—	100	5	E
054007-11928	V	16-14	—	100	5	E
054007-11939	V	12-10	—	50	10	E
054007-15678	V	8	—	25	10	E
054007-22203	N-G	22-18	—	100	5	F
054007-22211	Butt	SN	22-18	100	5	F
054007-23128	N-G	16-14	—	100	5	F
054007-23136	Butt	SN	16-14	100	5	F
054007-24035	N-G	12-10	—	50	10	F
054007-24043	Butt	SN	12-10	50	10	F
<b>Bullet (Grease Filled)</b>						
054007-23094	V	16-14	—	100	5	H
<b>Closed End</b>						
054007-16732	N	22-18	—	100	10	X
054007-16734	N	18-10	—	50	10	X

## 3M™ Black All-Weather Resistant Cable Ties

These ties have been manufactured with a special weather resistant formula that make them ideal for outdoor applications; they resist deterioration from the sun's ultra-violet light and as a result last far longer than natural colored nylon ties and many other black colored cable ties.



Part Number	Style	Length	Ties Per Bag	Ties Per Case
<b>Bag</b>				
054007-06200	Miniature	3-3/4"	100	1,000
054007-06201	Intermed.	5-7/8"	100	1,000
054007-06202	Standard	7-15/16"	100	1,000
054007-06203	Standard	12"	100	1,000
054007-06204	Standard	15"	100	500
054007-06205	Mounting	8-5/16"	100	1,000
054007-06207	Heavy Duty	15"	100	500
<b>Bulk</b>				
054007-06270	Miniature	3-3/4"	1,000	10,000
054007-06271	Intermed.	5-7/8"	1,000	10,000
054007-06272	Standard	7-15/16"	1,000	10,000
054007-06273	Standard	12"	1,000	10,000
054007-06274	Standard	15"	500	2,500
054007-06275	Mounting	8-5/16"	1,000	10,000
054007-06277	Heavy Duty	15"	500	2,500

# Electrical Products

## 3M™ Cable Ties

These ties resist flame, solvent, alkalis and grease. Available in lengths 3-3/4" through 15-5/8", in miniature, intermediate, standard and mounting type configurations. One piece nylon construction, single pawl with double-locking teeth holds without slipping.

Part Number	Style	Length	Ties Per Bag	Ties Per Case
<b>Bag</b>				
054007-06224	Miniature	3-3/4"	100	1,000
054007-06225	Intermed.	5-7/8"	100	1,000
054007-06226	Standard	7-15/16"	100	1,000
054007-06227	Standard	12"	100	1,000
054007-06228	Standard	15"	100	500
054007-06232	Mounting #10 Stud	8-5/16"	100	1,000
054007-06234	Mounting #10 Stud	15-7/16"	50	500
054007-06243	Heavy Duty Mounting	15-5/8"	100	1000
<b>Bulk</b>				
054007-06248	Miniature	3-3/4"	1,000	10,000
054007-06249	Intermed.	5-7/8"	1,000	10,000
054007-06250	Standard	7-15/16"	1,000	10,000
054007-06251	Standard	12"	1,000	10,000
054007-06252	Standard	15"	500	2,500
054007-06256	Mounting #10 Stud	8-5/16"	1,000	10,000
054007-06258	Mounting #10 Stud	15-7/16"	500	2,500
054007-06264	Heavy Duty	15"	500	2,500
054007-06267	Heavy Duty Mounting	15-5/8"	500	2,500

## 3M™ Black All-Weather Resistant Cable Ties — Heavy Duty

This heavy duty black cable tie is long lasting. Its special weather resistant formula effectively resists the deterioration from the sun's ultraviolet (U.V.) rays.



Part Number	Length	Ties Per Bag	Bags Per Case
054007-06208	32"	50	10

## 3M™ Black All-Weather Resistant Cable Ties — Extra Heavy Duty

This extra heavy duty cable tie is designed for the most demanding situations. Its 34" length and 175 lbs/inch tensile strength insures long lasting cable retention. This black tie resists weathering and the effects of ultraviolet (U.V.) light.



Part Number	Length	Ties Per Bag	Bags Per Case
054007-06209	34"	50	10

## 3M™ Cable Tie Assortment Pack

Use 3M™ Cable Ties with confidence when you secure wire bundles, harnesses and components. The flexible design allows you to slip ties easily under and around wires, cables and harnesses. The convenient assortment pack provides the customer with 100 ties of the most popular lengths.



Part Number	Ties Per Bag	Bags Per Case
054007-06220	100	10

Description	Length	Quantity	Type
Miniature	4"	15 Ea.	Natural
Miniature	4"	10 Ea.	Weather Res. Black
Intermediate	5"	15 Ea.	Natural
Intermediate	5"	10 Ea.	Weather Res. Black
Standard	7.5"	15 Ea.	Natural
Standard	7.5"	10 Ea.	Weather Res. Black
Standard	11"	15 Ea.	Natural
Standard	11"	10 Ea.	Weather Res. Black

## 3M™ 100 Hook-and-Loop Fastener

3M™ 100 Hook-and-Loop Fasteners incorporate flexibility, a thin profile, and superior strength for a unique cable bundling, harnessing and wire fastening system. 3M's 100 fasteners secure quickly and easily, remain locked without slipping and can be re-used for maximum efficiency. These fasteners are ideal for use on cable and wire assemblies, fiber optic installations or bundling and wrapping of most items.

Part Number	Size	Rolls Per Case
NEW 051128-53593	3/8" x 18 yds. – uncut roll	36
NEW 051128-53594	1/2" x 18 yds. – uncut roll	36
NEW 051128-53595	1" x 18 yds. – uncut roll	36
NEW 051128-53596	3/8" w/ 6" perforations – 100 count roll	36
NEW 051128-53597	1/2" w/ 6" perforations – 100 count roll	36
NEW 051128-53598	1" w/ 6" perforations – 100 count roll	36
NEW 051128-53599	3/8" w/ 8" perforations – 75 count roll	36
NEW 051128-53600	1/2" w/ 8" perforations – 75 count roll	36
NEW 051128-53601	1" w/ 8" perforations – 75 count roll	36

Part Number	Description	Dispensers Per Case
<b>Dispenser</b>		
NEW 051128-53604	Hand Held Dispenser	12

# Retail Packaged Electrical Products

## 3M™ Scotchlok™ Electrical Connectors Carded

Constructed of a "Live Spring" for strong, reliable wire contact which is enclosed in a crush-proof steel inner shell, then covered by a flexible PVC plastic that won't crack. Packed 10 cards per box; 5 boxes per case.



Part Number	Type	Wire Gauge	Connectors Per Card
054007-06110	"Y"	18-12	5
054007-06111	"R"	16-10	4
054007-06112	"G"	14-8	3

## Scotch® Super 33 Plus Vinyl Plastic Electrical Tape

An extremely conformable 7 mil high-performance tape that resists water, oils, acids and weather. Has insulation properties of both rubber and friction tapes. U.L. approved.



Part Number	Size	Rolls Per Case
054007-10414	3/4" x 450"	24
054007-10455	3/4" x 350"	24

## 3M™ Vinyl Plastic Electrical Tape

An economically priced tape. Seven mil thickness, tough and stretchy. Each roll cellophane wrapped. U.L. listed.



Part Number	Size	Rolls Per Case
054007-16736	3/4" x 300"	24

## 3M™ Scotchlok™ TH-440 Crimping Tool

The 3M™ Scotchlok™ TH-440 Crimping Tool is a compact, high-quality tool designed to perform the six most common electrical wiring functions. Made of .125 inch heat-treated carbon steel for maximum durability, it handles a variety of terminal and connector styles, insulated and non-insulated, over a range of 22-10 AWG.



Part Number	Tools Per Case
054007-60825	10

## 3M™ Scotchlok™ TH-450 Scissors Style Crimping Tool

The Scotchlok™ TH-450 is 3M's most versatile and heavy-duty tool. Made of high-strength-heat-treated carbon steel, the TH-450 is lightweight without sacrificing strength. It handles a variety of terminal and conductor styles, including flags, closed-end connectors, crimp sleeves and standard parts, both insulated and non-insulated. With a range of 26-6 AWG wire size, connections are U.L. approved when the crimping process is completed and the tool releases.



Part Number	Wire Range	Tools Per Case
054007-13760	26-6	10

# 3M™ ScotchPad™ Hang Tabs

## 3M™ ScotchPad™ Hang Tabs

3M™ ScotchPad™ Hang Tabs are made of clear, sturdy plastic and pressure-sensitive adhesive that will stick to most surfaces. They come on a convenient, self-sticking pad for easy manual application and portability. They are handy for hanging shrink-wrap packages as well as for in-store repair of damaged packaging, such as torn punches in chipboard header cards and plastic bags.

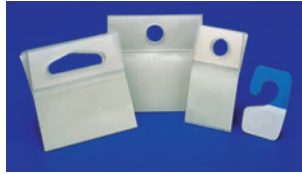

Part Number	Description	Hang Tabs Per Pad	Pads Per Case
021200- <b>62013</b>	3M™ ScotchPad™ #1075 2" x 2" Delta Hole Hang Tab	10	500
021200- <b>62014</b>	3M™ ScotchPad™ #1076 2" x 2" Round Hole Hang Tab	10	500
021200- <b>62225</b>	3M™ ScotchPad™ #1074 1" x 2" Mini Hang Tab	10	1000

# Post-it® Quality Flag

## Post-it® Quality Flag

These flags offer an easy and quick method of identifying areas of concern on many work surfaces. Attention-getting colored flag (yellow with black lettering "QUALITY") that adheres to any surface without contamination. Dispenser holds the flags and offers an automatic pop-up feature. Dispenser size is 1" x 1.7".



Part Number	Flags Per Dispenser	Dispensers Per Case
021200- <b>71450</b>	75	100

# Laminating Systems

## 3M™ Laminating System LS950

A heat-free way to finish documents up to 8-1/2" wide in one system! Laminate, for instant document protection; apply adhesive, for permanent self-stick labels and signs; or do both at once to create laminated, permanent labels in seconds.



Part Number	Product Number	Each Per Case
021200-59151	LS950	1

## 3M™ Dual Laminate Refill Cartridge DL951

For use with the 3M™ Laminating System LS950. Front and back side lamination. Great for presentations, 3-ring binder sheets, schedules and more. 2.5 mil thickness, 8-1/2" wide x 100' long, approximately 100 8-1/2" x 11" applications.



Part Number	Product Number	Size	Each Per Case
021200-59152	DL951	100' x 8-1/2"	1

# Point of Sale Displays

## Wax & Maintenance 6 Pack Rack

Holds six bottles of 3M™ Marine Fiberglass Restorer and Wax (PN09005), or 3M™ Marine Fiberglass Cleaner and Wax (PN09009), or 3M™ Marine Super Duty Rubbing Compound (PN09004) or 3M™ Marine Finesse-It™ II Finishing Material (PN09048). **NOTE: PRODUCTS DO NOT COME WITH THE DISPLAY.**



Part Number	Description	Racks Per Case
NEW 051131-03004	Rack	6

## Tape Racks

Six tape racks with headers point of sale display for marine application. **NOTE: PRODUCTS DO NOT COME WITH THE DISPLAY.**

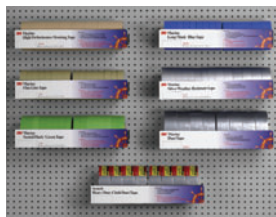

Part Number	Description	Racks Per Case
NEW 051131-03005	Rack	6

## 3M™ Marine Adhesive/Sealant 5200 Floor Display

This display is for retailers and yards with 5200 customers. Floor display consists of 108 cartridges of 3M™ Marine Adhesive/Sealant 5200 (PN06500). The display ships complete; take "shroud" off and it is ready to sell. Top row already cut for display. Sell thru each tray, remove or refill.

Part Number	Displays Per Case
051135-06499	1

## Plastic Bulk Abrasives Rack 503

Each rack contains 8 plastic trays including bulk abrasives labels and headers kit. Case dimensions: 14" x 16.5" x 34.5".

Part Number	Racks Per Case
NEW 051135-64666	1

(Not stocked as a 3M item. Contact your Marine Sales Representative for ordering information.)



# Index

## by Part Number

Part No.	Page No.	Part No.	Page No.	Part No.	Page No.	Part No.	Page No.
CB-1000	158	L-125-2	155	R2071	170	W-3195	161
FT-10	163	L-126-2	155	R2091	170	W-3196	161
FT-11	163	L-127	155	R6022	170	W-3197	161
FT-12	163	L-128-2	155	R6885ES	170	W-3217	161
FT-13	163	L-129-2	155	R7511ES	171	W-3222-2	157
FT-14	163	L-130	155	R7512ES	171	W-3229	161
FT-15	163	L-131-10	155	R7513ES	171	W-3258-5	157
FT-20	163	L-132-10	155	R7530ES	171	W-3261	157
FT-30	163	L-133-100	155	R8511ES	169	W-3262-10	157
FT-31	163	L-133-25	155	RCSCD	163	W-3265-SL	161
FT-32	163	L-134-10	155	SSCD	163	W-3265-SM	161
GVP-100	158	L-136	156	T100	172	W-3266	161
GVP-101	158	L-137	156	T126	172	W-3267	161
GVP-110	158	L-140-10	156	T151	172	W-3268-5	161
GVP-111	158	L-141	156	T156	172	W-3269	161
GVP-112	158	L-142-2	156	T157	172	W-3270-10	161
GVP-113	158	L-145-10	156	T210	172	W-3271-5	161
GVP-114	158	L-146	156	T240	172	W-5102-2	157
GVP-115	158	L-147-2	156	T270	172	W-5114	157, 159
GVP-116	158	L-149-10	156	T280	172	W-9435-100	159, 161
GVP-117	158	L-150	156	T30	172	W-9435-25	159, 161
GVP-118	158	L-152-5	156	V-100	156	W-9435-50	159, 161
GVP-119	158	L-153	156	V-100-SS	156	021200-00002	101
GVP-122	157	L-156	156	V-111	156	021200-00006	124
GVP-122	158	L-162-2	156	V-115	156	021200-00007	124
GVP-123	158	L-163	156	V-117	156	021200-00008	124
GVP-127	158	L-165	156	V-150	156	021200-00009	124
GVP-128	158	L-181	156	V-150-SS	156	021200-00010	124
GVP-401	158	L-182	156	V-200	156	021200-00011	124
GVP-402	158	L-183	156	V-200-SS	156	021200-00012	124
GVP-403	158	L-184	156	V-211	156	021200-00013	124
GVP-440	158	L-501	155	V-215	156	021200-00014	124
GVP-441	158	L-503	155	V-250	156	021200-00015	124
GVP-442	158	L-505	155	V-250-SS	156	021200-00016	124
GVP-443	158	L-550	156	V-300	156	021200-00017	124
GVP-CB	158	L-701	155	V-300-SS	156	021200-00018	124
GVP-PSK/07190	158	L-703	155	V-350	156	021200-00019	124
H-110-10	157	L-705	155	V-350-SS	156	021200-00020	124
H-111-100	157	L-750	156	V-400	156	021200-00021	124
H-113-2	157	L-901	155	W-2806	159	021200-00213	98
H-114-2	157	L-905	155	W-2808	159	051131-00298	14
H-115	157	L-950	156	W-2811-10	159	051131-00299	14
H-116-2	157	MDC22DD	173	W-2862	159	051131-00300	14
H-410-10	157	MFL550DD	173	W-2870-5	157	051131-00301	14
H-411	157	MRG36300E	173	W-2871-5	157	051131-00302	14
H-412	157	MRGC36100E	173	W-2878-2	157	051131-00303	14
H-420-10	157	MRL15150DD	173	W-2879	157	051131-00304	14
H-421	157	MRL38150DD	173	W-2907	159	051131-00305	14
H-422	157	PFL550DD	172	W-2915	159	051131-00306	14
H-610-5	157	PSKFL31	173	W-2921	159	051131-00307	14
H-611	157	PSKFL5	172	W-2923	159	051131-00308	14
H-612	157	R1425ES	170	W-2933	161	051131-00309	14
HCSCD	163	R1427ES	170	W-2954	161	051131-00322	14
HP100	172	R1611ES	170	W-3012	159	051131-00323	14
HP156	172	R1620ES	170	W-3013-4	159	051131-00324	14
HP157	172	R1621ES	170	W-3018	159	051131-00325	14
HP255	172	R1631ES	171	W-3020-100	159, 161	051131-00326	14
HP256	172	R1700ES	171	W-3020-25	159, 161	051131-00327	14
L-112-2	155	R1701ES	171	W-3020-50	159, 161	051131-00328	14
L-113-2	155	R1710ES	171	W-3046	159	051131-00329	14
L-114-2	155	R1712ES	171	W-3060-100	161	051131-00330	14
L-115-10	155	R1720ES	171	W-3060-25	161	051131-00331	14
L-116-2	155	R1721ES	171	W-3060-50	161	051131-00332	14
L-117-2	155	R1911ES	171	W-3062	161	051131-00333	14
L-120-5	155	R1912ES	171	W-3096	159	051131-00366	14
L-121-5	155	R1921ES	171	W-3099	159	051131-00367	14
L-122	155	R1922ES	171	W-3187	161	051131-00368	14
L-123-2	155	R1931ES	171	W-3188	161	051131-00369	14
L-124-5	155	R1932ES	171	W-3194	161	051131-00371	14



Part No.	Page No.	Part No.	Page No.	Part No.	Page No.	Part No.	Page No.
051131-00372	14	051131-00516	25	051131-00771	53	051131-00954	24
051131-00373	14	051131-00520	25	051131-00772	53	051131-00955	24
051131-00374	14	051131-00521	25	051131-00773	53	051131-00956	24
051131-00375	14	051131-00522	25	051131-00774	53	051131-00957	24
051131-00377	14	051131-00524	25	051131-00775	53	051131-00958	24
051131-00378	14	051131-00525	25	051131-00776	53	051131-00959	24
051131-00379	14	051131-00538	37	051131-00778	53	051131-00960	24
051131-00380	14	051131-00539	37	051131-00779	53	051131-00961	24
051131-00381	14	051131-00540	37	051131-00780	53	051131-00962	24
051131-00389	32	051131-00542	37	051131-00781	53	051131-00963	24
051131-00390	32	051131-00543	37	051131-00782	53	051131-00964	24
051131-00391	32	051131-00552	56	051131-00783	53	051131-00965	24
051131-00392	32	051131-00553	56	051131-00784	53	051131-00966	24
051131-00393	32	051131-00554	56	051131-00785	53	051131-00967	24
051131-00394	32	051131-00555	56	051131-00786	53	051131-00968	24
051131-00395	14	051131-00556	56	051131-00787	53	051131-00969	24
051131-00396	14	051131-00612	56	051131-00788	53	051131-00970	24
051131-00397	14	051131-00615	56	051131-00789	53	051131-00971	24
051131-00399	14	051131-00616	56	051131-00790	53	051131-00972	24
051131-00400	14	051131-00620	56	051131-00791	53	051131-00973	24
051131-00401	14	051131-00621	56	051131-00792	53	051131-00974	24
051131-00402	14	051131-00624	56	051131-00793	53	051131-00975	24
051115-00402	33	051131-00625	56	051131-00794	53	051131-00976	24
051131-00403	14	051131-00638	56	051131-00795	53	051131-00977	24
051131-00405	50	051131-00639	56	051131-00796	53	051131-00978	24
051131-00406	50	051131-00642	56	051131-00799	34	051131-00979	24
051131-00407	50	051131-00643	56	051131-00800	34	051131-00980	24
051131-00408	50	048011-00645	67	051131-00801	34	051131-00981	24
051131-00410	50	051131-00656	21	051131-00802	34	051131-00982	24
051131-00411	50	051131-00657	21	051131-00803	34	051131-00983	24
051131-00413	50	051131-00658	21	051131-00828	21	051131-00984	24
051131-00414	50	051131-00659	21	051131-00829	21	051131-00985	24
051131-00415	50	051131-00660	21	051131-00830	21	051131-00986	24
051131-00417	50	051131-00661	21	051131-00833	21	051131-00987	24
051131-00418	50	051131-00662	21	051131-00834	21	051131-00988	24
051131-00419	50	051131-00663	21	051131-00835	21	051131-00990	24
051131-00420	50	051131-00664	21	051131-00836	21	051131-00998	24
051131-00421	50	051131-00665	21	051131-00837	21	051131-00999	24
051131-00422	50	051131-00666	21	051131-00843	21	021200-01008	101
051131-00423	50	051131-00667	21	051131-00844	21	021200-01009	101
051131-00424	50	048011-00670	67	051131-00845	21	021200-01010	101
051131-00425	50	051131-00672	21	051131-00850	21	051131-01019	27
051131-00426	50	051131-00673	21	051131-00851	21	051131-01020	27
051131-00427	50	051131-00674	21	051131-00852	21	051131-01022	27
051131-00428	50	051131-00675	21	051131-00853	21	051131-01023	27
051115-00438	36	051131-00676	21	051131-00854	21	051131-01024	27
051115-00444	108	051131-00677	21	051131-00855	21	051131-01025	27
051115-00445	108	051131-00678	21	051131-00868	21	051131-01026	27
051131-00469	50	051131-00679	21	051131-00869	21	051131-01027	27
051131-00470	50	051131-00680	21	051131-00870	21	051131-01028	27
051131-00471	50	051131-00681	21	051131-00871	21	051131-01034	27
051131-00473	50	051131-00682	21	051131-00907	24	051131-01035	27
051131-00474	50	051131-00683	21	051131-00908	24	051131-01037	27
051131-00475	50	051131-00684	21	051131-00909	24	051131-01038	27
051131-00476	50	051131-00685	21	051131-00910	24	051131-01039	27
051131-00477	50	051131-00686	21	051131-00911	24	051131-01040	27
051131-00479	50	051131-00687	21	051131-00912	24	051131-01041	27
051131-00480	50	051131-00688	21	051131-00913	24	051131-01042	27
051131-00481	50	051131-00690	21	051131-00914	24	051131-01043	27
051131-00482	50	051131-00750	53	051131-00915	24	051131-01044	55
051131-00483	50	051131-00751	53	051131-00916	24	051131-01045	55
051131-00506	25	048011-00751	67	051131-00917	24	051131-01046	55
051131-00507	25	051131-00752	53	051131-00918	24	051131-01047	55
051131-00508	25	048011-00752	67	051131-00919	24	051131-01048	55
051131-00509	25	051131-00753	53	051131-00920	24	051131-01049	55
051131-00510	25	051131-00754	53	051131-00921	24	051131-01050	55
051131-00511	25	051131-00755	53	051131-00950	24	051131-01053	55
051131-00512	25	051131-00768	53	051131-00951	24	051131-01055	55
051131-00513	25	051131-00769	53	051131-00952	24	051131-01057	55
051131-00515	25	051131-00770	53	051131-00953	24	051131-01059	55

Part No.	Page No.	Part No.	Page No.	Part No.	Page No.	Part No.	Page No.
051131-01060	55	051131-01327	15	051131-01485	16	051131-01728	23
051131-01062	55	051131-01328	15	051131-01487	16	051131-01729	23
051131-01063	55	051131-01329	15	051131-01488	16	051131-01730	23
051131-01064	55	051131-01330	15	051131-01489	16	051131-01733	23
051131-01065	55	051131-01331	15	051131-01490	16	051131-01734	23
051131-01066	55	051131-01332	15	051131-01491	16	051131-01735	23
051131-01067	55	051131-01333	15	051131-01492	16	051144-01738	59
051131-01068	55	051131-01336	15	051131-01493	16	051144-01739	59
051131-01069	55	051131-01372	51	051144-01501	16	051144-01740	59
051131-01070	55	051131-01373	51	051131-01502	27	051131-01743	23
051131-01071	55	051131-01374	51	051144-01505	18	051131-01744	23
051131-01072	55	051131-01375	51	051144-01506	16	051131-01745	23
051131-01073	55	051131-01376	51	051131-01507	27	021200-01748	98
051131-01074	55	051131-01377	51	051144-01536	18	051131-01756	23
051131-01075	55	051131-01378	51	051144-01537	18	051131-01757	23
051131-01076	55	051131-01379	51	051144-01538	18	051131-01759	23
051131-01077	55	051131-01380	51	051144-01539	18	051131-01760	23
051131-01078	55	051131-01381	51	051144-01540	18	051144-01760	59
051131-01079	55	051131-01382	51	051144-01541	18	051131-01761	23
051131-01080	55	051131-01383	51	051144-01542	18	051144-01761	59
051131-01081	55	051131-01396	59	051131-01545	17	051131-01762	23
051131-01082	55	051131-01397	59	051131-01546	17	051131-01763	23
021200-01082	101	051131-01398	59	051131-01547	17	051131-01764	23
051131-01083	55	051131-01406	59	051131-01548	17	051131-01765	23
051144-01099	28	051131-01407	59	051131-01549	16	051131-01766	23
051144-01100	28	051131-01408	59	051131-01550	17	051131-01767	23
051144-01102	28	051131-01417	16	051131-01551	17	051131-01768	23
051144-01103	28	051131-01418	16	051131-01552	16	051131-01769	35
051144-01104	28	051131-01419	16	051131-01556	16	051131-01770	23
051144-01105	28	051144-01420	16	051131-01561	52	051131-01771	23
051144-01106	28	051144-01421	16	051131-01566	52	051131-01772	23
051144-01107	28	051144-01422	16	051131-01569	52	051131-01773	23
051144-01108	28	051144-01423	16	051131-01619	51	051131-01774	23
051144-01109	28	051144-01424	16	051131-01620	51	051131-01775	23
051144-01110	28	051144-01425	16	051131-01621	51	051131-01776	23
051144-01111	28	051144-01426	16	051131-01622	51	051131-01777	23
051144-01112	28	051144-01427	16	051131-01623	51	051131-01778	23
051144-01113	28	051144-01428	16	051131-01624	51	051131-01779	23
051144-01114	28	051131-01432	16	051131-01625	51	051131-01780	23
051144-01123	28	051131-01433	16	051131-01626	51	051131-01781	23
051144-01124	28	051131-01434	16	051131-01627	51	051131-01782	23
051144-01126	28	051144-01435	16	051131-01628	51	051131-01791	35
051144-01129	28	051144-01436	16	051131-01633	51	051131-01793	35
051144-01133	28	051144-01437	16	051131-01634	51	051131-01794	35
051144-01136	28	051144-01438	16	051131-01635	51	051144-01818	59
051144-01139	28	051144-01439	16	051131-01636	51	051144-01819	59
051144-01143	28	051144-01440	16	051131-01637	51	051144-01820	59
051144-01146	28	051144-01441	16	051131-01638	51	051144-01833	59
051144-01149	28	051144-01442	16	051131-01639	51	051144-01834	59
051131-01202	16	051144-01443	16	051131-01640	51	051144-01835	59
051131-01203	16	051144-01450	18	051131-01641	51	051144-01867	59
051131-01204	16	051144-01451	18	051131-01642	51	051144-01868	59
051131-01205	16	051144-01452	18	051131-01643	51	051144-01880	58
051131-01206	16	051144-01453	18	051131-01645	27	051144-01881	58
051131-01207	16	051144-01454	18	051131-01647	27	051144-01893	58
051131-01208	16	051144-01455	18	051131-01648	27	051144-01894	58
051131-01214	16	051144-01456	18	051131-01649	27	051144-01906	58
051131-01215	16	051144-01457	18	051131-01651	27	051144-01907	58
051131-01216	16	051144-01458	18	051131-01652	25	051131-01913	58
051131-01217	16	051144-01465	18	051131-01656	25	051131-01914	58
051131-01311	15	051144-01466	18	051131-01660	52	051144-01915	58
051131-01318	15	051144-01467	18	051131-01661	52	051131-01916	58
051131-01319	15	051144-01468	18	051131-01665	52	051131-01921	58
051131-01320	15	051144-01469	18	051131-01667	52	051131-01922	58
051131-01321	15	051144-01470	18	051131-01668	52	051144-01923	58
051131-01322	15	051144-01471	18	051144-01720	59	051131-01924	58
051131-01323	15	051144-01472	18	051144-01722	59	051131-01927	58
051131-01324	15	051144-01473	18	051144-01724	59	051131-01928	58
051131-01325	15	051131-01483	16	051144-01725	59	051144-01929	58
051131-01326	15	051131-01484	16	051144-01727	59	051131-01930	58

Part No.	Page No.	Part No.	Page No.	Part No.	Page No.	Part No.	Page No.
051131-01970	62	051131-02226	41	051131-02548	40	051131-03055	71
051131-01971	62	051131-02227	41	051131-02549	40	051131-03057	71
051131-01972	62	051131-02230	32	051131-02551	40	021200-03119	109
051131-01973	62	051144-02231	32	051131-02552	40	021200-03120	109
051131-01974	62	051144-02232	32	051131-02553	40	021200-03121	109
051131-01975	62	051144-02241	32	051131-02554	40	021200-03135	111
051131-01987	61	051144-02248	32	051144-02556	32	021200-03136	111
051131-01988	61	051144-02249	32	051144-02559	32	051131-03171	72
051131-01989	61	051131-02254	39	051144-02560	32	051131-03172	72
051131-01990	61	051131-02255	39	051144-02561	32	021200-03174	110
051131-01991	61	051131-02256	39	051144-02562	32	021200-03175	110
051131-01994	61	051131-02258	39	051144-02563	32	051144-03192	69
051144-02000	38	051131-02259	39	051131-02565	32	021200-03291	122
051144-02001	38	051144-02338	40	051131-02566	40	021200-03314	122
051144-02002	38	051144-02342	41	051131-02567	40	021200-03318	122
051144-02003	38	051144-02344	41	051131-02568	40	021200-03319	122
051144-02004	38	051144-02345	41	051131-02569	40	021200-03320	122
051144-02005	38	051144-02346	41	051131-02589	32	021200-03337	120
051144-02006	38	051144-02347	41	051131-02590	32	021200-03394	121
051144-02007	38	051144-02348	41	051131-02591	32	051131-03455	182
051144-02014	38	051144-02349	41	051131-02593	32	051131-03456	182
051144-02015	38	051144-02350	41	051131-02594	32	051131-03457	182
051144-02016	38	051144-02351	41	051131-02595	32	051131-03458	182
051144-02017	38	051144-02352	41	051131-02596	32	051131-03459	182
051144-02018	38	051144-02353	41	051131-02597	32	051131-03460	182
051131-02019	38	051144-02355	41	051131-02598	32	051131-03461	182
051144-02019	38	051144-02356	41	051131-02599	32	051131-03462	182
051131-02020	38	051144-02359	41	051131-02600	42	051131-03463	182
051144-02021	38	051144-02360	41	051131-02601	42	051131-03464	182
051131-02022	38	051144-02361	41	051131-02602	42	051131-03587	100
051131-02023	38	051144-02362	41	051131-02604	42	03587CS	100
051131-02032	38	051144-02380	41	051131-02606	42	021200-04230	108
051131-02033	38	051144-02382	41	051131-02630	35	048011-04305	67
051131-02034	38	051144-02383	41	051131-02631	35	048011-04306	67
051131-02035	38	051144-02384	41	051131-02632	35	021200-04319	110
051131-02036	38	051144-02385	41	051131-02633	35	021200-04365	108
051131-02037	38	051144-02386	41	051131-02634	35	021200-04597	110
051131-02038	38	051144-02387	41	051131-02637	35	021200-04698	109
051131-02039	38	051144-02393	40	051131-02638	35	021200-04699	109
051131-02040	38	051144-02394	40	051131-02639	35	021200-04700	109
051131-02041	38	051144-02397	40	051131-02640	35	021200-04701	109
051131-02042	38	051144-02400	40	051131-02641	35	021200-04850	120
051131-02043	38	051144-02431	41	051131-02669	34	021200-04968	109
051131-02044	38	051144-02432	41	051131-02670	34	051144-05002	43
051131-02045	38	051144-02433	41	051131-02672	34	051144-05003	43
051144-02088	38	051144-02435	41	051131-02673	34	051144-05004	43
051144-02103	40	051131-02469	37	051131-02689	32	051144-05005	43
051144-02104	40	051131-02470	37	051131-02691	32	051144-05006	43
051144-02106	40	051131-02472	37	051131-02693	32	051144-05007	43
051144-02107	40	051131-02473	37	051131-02694	32	051144-05008	43
051144-02108	40	051131-02500	44	051131-02695	32	051144-05009	43
051144-02112	40	051115-02501	108	051131-02696	32	051144-05022	43
051144-02113	40	051115-02502	108	051131-02697	32	051144-05024	43
051144-02114	40	051131-02508	133	051131-02698	32	051144-05025	43
051144-02115	40	051131-02509	133	021200-02828	110	051144-05026	43
051144-02116	40	051131-02510	44	021200-02829	110	051144-05027	43
051144-02117	40	051131-02513	39	021200-02830	110	051144-05028	43
051144-02118	40	051131-02514	44	021200-02991	108	051144-05029	43
051144-02119	40	051131-02536	40	021200-02992	108	051144-05030	43
051144-02133	40	051131-02537	40	021200-02993	108	051144-05032	43
051144-02134	40	051131-02538	40	021200-02994	108	051144-05042	43
051144-02135	40	051131-02539	40	051131-03004	88, 196	051144-05043	43
051144-02136	40	051131-02540	40	051131-03005	124, 196	051144-05044	43
051144-02138	40	051131-02541	40	021200-03027	116	051144-05045	43
051144-02139	40	051131-02542	40	021200-03047	120	051144-05046	43
051144-02176	40	051131-02543	40	051131-03050	71	051144-05047	43
051131-02220	41	051131-02544	40	051131-03051	71	051144-05048	43
051144-02221	41	051131-02545	40	051131-03052	71	051144-05049	43
051144-02222	41	051131-02546	40	051131-03053	71	051144-05050	43
051131-02225	41	051131-02547	40	051131-03054	71	051144-05052	43

Part No.	Page No.	Part No.	Page No.	Part No.	Page No.	Part No.	Page No.
051144-05054	43	051144-05580	28	051131-05881	57	054007-06171	191
051135-05203	131	051131-05581	20	051131-05912	129	054007-06172	191
051135-05205	131	051131-05582	20	051131-05915	129	054007-06192	121
051135-05206	131	051144-05585	20	051131-05916	129	054007-06195	121
051135-05220	131	051144-05586	20	051131-05919	129	054007-06196	121
051131-05240	34	051131-05591	20	051131-05928	88, 92, 95	054007-06200	192
051131-05241	34	021200-05617	108	051131-05929	88, 92, 95	054007-06201	192
051131-05242	34	021200-05618	108	051131-05933	91	054007-06202	192
051131-05244	34	021200-05619	108	051131-05934	91	054007-06203	192
051131-05245	22	021200-05620	108	051131-05936	91	054007-06204	192
051131-05246	34	021200-05621	108	051135-05937	92	054007-06205	192
051131-05248	34	051131-05632	60	051135-05938	92	054007-06207	192
051131-05251	22	051131-05645	52	051131-05940	91	054007-06208	193
051131-05255	22	051131-05646	52	051135-05941	92	054007-06209	193
051135-05260	131	051131-05655	52	051135-05943	92	051135-06213	14
051135-05261	131	051131-05656	52	051131-05954	88, 91, 95	051135-06214	14
051131-05268	22	048011-05680	66	051144-05955	88, 91, 95	051135-06216	14
051131-05273	22, 54	051131-05681	52	051144-05960	75	051135-06217	14
051131-05274	22, 54	051131-05682	52	051131-05962	75	051135-06218	14
051131-05275	22	051144-05700	93	051144-05964	75	051135-06219	14
051131-05276	22	051144-05701	93	051144-05966	75	051135-06220	14
051131-05279	22	051131-05703	93	051131-05975	168	054007-06220	193
051135-05280	132	051131-05704	93	051131-05990	92	051135-06221	14
051131-05281	22	051144-05705	93	051131-05991	92	051135-06222	14
051131-05282	22	051144-05710	93	051131-05992	92	054007-06224	193
051131-05283	22	051131-05711	93	051131-05995	92	054007-06225	193
051131-05286	22	051131-05713	93	051131-05996	92	054007-06226	193
051131-05291	22	051131-05717	93	051131-06000	92	054007-06227	193
051131-05292	22	051131-05718	94	051131-06001	92	054007-06228	193
051131-05345	54	051131-05719	93	051131-06009	92	054007-06232	193
051131-05351	54	051131-05725	94	051131-06011	91	054007-06234	193
051131-05355	54	051131-05740	37	051131-06021	91	054007-06243	193
051131-05356	54	051131-05741	37	051131-06025	91	054007-06248	193
051131-05375	54	051131-05742	37	051131-06026	91	054007-06249	193
051131-05380	54	051131-05744	37	051131-06027	91	054007-06250	193
051131-05381	54	051131-05747	26	051131-06031	91	054007-06251	193
051131-05382	54	051131-05748	37	051131-06039	91	054007-06252	193
021200-05418	111	051131-05750	37	051131-06044	91	054007-06256	193
021200-05419	111	051131-05755	26	051131-06045	91	054007-06258	193
021200-05420	111	051131-05756	26	054007-06106	190	054007-06264	193
021200-05421	111	051131-05757	57	054007-06108	190	054007-06267	193
021200-05423	109	051131-05766	73, 74	054007-06110	194	054007-06270	192
051144-05440	33	051131-05768	26	054007-06111	194	054007-06271	192
051144-05441	33	051131-05769	26	054007-06112	194	054007-06272	192
051144-05442	33	051131-05773	26, 57	054007-06118	190	054007-06273	192
051144-05444	33	051131-05774	26, 57	054007-06119	190	054007-06274	192
051144-05446	33	051131-05775	26	054007-06120	190	054007-06275	192
051144-05448	33	051131-05776	26	054007-06122	190	054007-06277	192
051144-05450	20	051131-05779	26	054007-06123	190	021200-06300	109
051131-05451	20	051131-05781	26	054007-06126	190, 191	021200-06301	109
051144-05452	33	051131-05782	26	054007-06127	190	021200-06302	109
051144-05517	39	051131-05791	26	054007-06128	190	021200-06303	109
051144-05518	39	051131-05792	26	054007-06129	190	021200-06305	109
051144-05519	42	021200-05797	111	054007-06130	186	021200-06306	109
051131-05520	42	051131-05801	74	054007-06132	186	021200-06307	109
051131-05526	39	051131-05802	74	054007-06133	186	021200-06308	109
051144-05530	33	051131-05803	74	054007-06134	190	021200-06312	109
051144-05539	60, 66, 68	051131-05821	75	054007-06135	190	021200-06314	109
051144-05540	60, 66, 68	051131-05830	74	054007-06141	192	051131-06315	109
051131-05541	60	051131-05842	73	054007-06143	186	051131-06316	109
051131-05545	20	051131-05843	73	054007-06144	192	051131-06317	109
051131-05546	20	051131-05844	73	054007-06147	189	051131-06318	109
051131-05555	20	051131-05845	74	054007-06149	189	051131-06319	109
051131-05556	20	051131-05848	57	054007-06150	192	051131-06320	109
051131-05568	20	051131-05855	57	054007-06152	191, 192	051131-06322	109
051144-05575	20	051131-05856	57	054007-06153	192	051131-06323	109
051144-05576	20	051131-05860	44	054007-06154	192	051131-06324	109
051144-05577	28	051131-05861	44	054007-06160	191	051131-06325	109
051144-05578	28	051131-05868	74	054007-06161	191	021200-06330	108
051144-05579	20	051131-05876	57	051131-06165	186	021200-06332	108

Part No.	Page No.	Part No.	Page No.	Part No.	Page No.	Part No.	Page No.
021200-06334	108	051131-06603	125	021200-06888	119	051131-07500	65
021200-06335	108	021200-06606	125	021200-06889	119	051131-07501	65
021200-06336	108	051131-06609	125	051131-06893	118	051131-07502	65
021200-06338	108	021200-06612	125	051131-06894	118	051131-07504	67
021200-06340	108	021200-06615	125	051131-06895	118	051131-07505	67
021200-06341	108	021200-06618	125	051131-06896	118	051131-07506	67
021200-06343	108	051131-06624	125	051131-06897	118	051131-07507	67
021200-06344	108	051131-06634	118	051131-06898	118	051131-07508	67
021200-06346	108	051131-06635	118	051115-06904	125	051131-07509	67
051131-06357	108	021200-06636	125	021200-06908	123	051131-07511	66
051131-06359	108	051131-06639	117	021200-06910	123	051131-07512	66
051131-06363	108	051131-06640	117	021200-06923	123	051131-07513	66
051131-06396	132	051131-06641	117	021200-06925	123	051131-07514	66
051131-06404	109	051131-06642	117	021200-06927	120, 123	051131-07515	66
021200-06405	109	051131-06647	117	051131-06937	118	051131-07516	66
051131-06408	109	051131-06648	117	051131-06938	118	051131-07517	65
051131-06409	109	051131-06696	126	051131-06939	118	051131-07519	65
051131-06439	122	051131-06697	126	021200-06941	119	051131-07521	63
051131-06440	122	051131-06706	124	021200-06943	119	051131-07522	63
051131-06443	122	051131-06708	125	021200-06944	123	021200-07689	111
051131-06446	122	051131-06710	125	021200-06945	111	021200-07690	111
021200-06452	122	051131-06711	125	021200-06947	119	07729	174
021200-06455	122	051131-06712	124	051131-06950	119	07730	174
021200-06458	122	051131-06713	125	051131-06951	119	07731	174
051131-06463	142	051131-06714	125	021200-06953	123	07732	174
051131-06464	140	051131-06715	124	051131-06954	119	07733	174
051131-06465	140	051131-06716	125	021200-06955	123	07734	175
051131-06480	141	051131-06717	125	051115-06964	42	07735	175
051131-06481	140	051131-06718	124	051115-06965	42	07736	175
051131-06483	142	051131-06726	124	051115-06966	42	07737	175
051131-06484	142	051131-06727	126	051131-06969	116	07738	175
051131-06488	140	051131-06728	126	051131-06975	116	07739	175
051131-06491	120	051131-06729	124	051131-06984	116	07740	175
051131-06492	120	051131-06732	124	051131-06993	123	07741	175
051131-06493	120	051131-06736	124	051131-06995	116	07742	176
051131-06494	120	051131-06738	124	051131-06997	123	07743	176
051135-06499	131, 196	051131-06739	126	051131-07177	151	07744	176
051135-06500	131	051131-06740	126	051131-07178	151	07745	176
051135-06501	131	051131-06780	126	051131-07179	151	07747	174
051135-06502	131	051131-06781	128	051131-07195	152	07748	174
021200-06503	124	051131-06782	128	051131-07410	65	07749	174
051135-06504	131	051131-06783	128	051144-07413	69	07750	176
021200-06506	124	051131-06784	128	051144-07414	69	07751	176
051131-06507	125	051131-06787	127	051144-07415	69	07752	176
051131-06508	125	051131-06788	126	051131-07439	63	07753	176
021200-06509	124	051131-06794	127	051131-07441	63	051115-07921	36
051131-06510	125	051131-06795	127	051131-07442	63	051115-07922	36
051135-06510	132	051131-06796	127	051131-07443	65	051115-07923	36
021200-06512	124	051131-06797	127	051131-07444	65	051115-07924	36
021200-06515	124	051131-06798	127	051131-07445	63	051115-07925	36
021200-06518	124	051131-06802	126	051131-07447	63	051115-07926	36
051131-06520	125	051131-06804	127	051131-07448	63	051115-07934	36
051135-06520	131	021200-06810	128	048011-07450	67	051115-07935	36
051131-06521	125	021200-06814	128	048011-07451	67	051115-07936	36
021200-06524	124	051115-06817	110	051131-07453	67	051115-07937	36
051131-06525	125	051115-06818	110	051131-07455	67	051115-07938	36
051131-06527	125	051115-06819	110	051131-07456	67	051115-07939	36
021200-06530	124	051115-06820	110	051131-07457	67	051131-07950	184
021200-06536	124	051131-06821	119	051131-07466	65	051131-07951	184
051131-06537	125	051131-06845	126	051131-07467	67	051131-07952	184
051131-06538	125	051131-06848	126	051131-07468	67	051115-07997	126
051131-06539	125	021200-06864	128	051131-07480	66	051135-08001	134
051135-06539	141	021200-06865	128	051131-07481	66	051135-08011	134
051131-06540	125	021200-06866	128	051131-07482	66	051135-08017	132
051135-06560	131	021200-06869	128	051131-07483	66	051135-08019	132
051135-06564	131	021200-06871	128	051131-07485	66	051135-08027	132
06566	131	051115-06875	36	051131-07486	66	051135-08029	132
06568	131	051115-06876	36	048011-07492	67	051135-08031	134
051135-06580	132	051115-06882	36	051131-07493	67	021200-08032	108
051135-06586	132	051115-06883	36	048011-07494	67	021200-08034	108

Part No.	Page No.	Part No.	Page No.	Part No.	Page No.	Part No.	Page No.
021200-08035	108	051131-09035	90, 97	054007-09424	187	054007-11222	186
051135-08051	134	051131-09038	90, 94, 97	054007-09425	187	051144-11287	18
051135-08054	28, 134	051131-09047	90, 97	054007-09426	187	051144-11289	18
051131-08074	134	051131-09048	88, 92, 95	054007-09427	187	1130	164
051135-08088	134	054007-09056	189	054007-09428	187	054007-11820	191, 192
051135-08089	134	051131-09059	90, 96	054007-09429	187	054007-11822	191, 192
051131-08090	134	051131-09060	90, 96	054007-09430	187	051144-11824	60
051135-08091	134	051131-09063	90, 97	054007-09431	187	054007-11900	191
051135-08101	134	051144-09084	69	048011-09450	66, 67	054007-11913	191, 192
051135-08107	135	051144-09085	69	048011-09451	67	054007-11914	191, 192
048011-08148	182	051144-09086	69	048011-09457	182	054007-11915	191, 192
051135-08155	135	051144-09087	69	054007-09458	187	054007-11918	191, 192
051135-08191	135	051144-09088	69	054007-09482	189	054007-11919	191, 192
051135-08197	135	051144-09100	70	054007-09483	189	054007-11920	191, 192
048011-08251	63	051144-09101	70	054007-09484	189	054007-11921	191, 192
048011-08293	64	051144-09102	70	054007-09485	189	054007-11922	191, 192
051135-08398	133	051144-09103	70	054007-09486	189	054007-11923	191, 192
048011-08554	182	051144-09104	70	054007-09487	189	054007-11924	191, 192
051135-08578	134	051144-09105	72	048011-09489	64	054007-11926	191, 192
051135-08672	135	051144-09106	71	054007-09656	186	054007-11927	191, 192
051135-08700	138	051144-09140	70	054007-09915	189	054007-11928	191, 192
051135-08707	138	051144-09141	70	054007-09916	189	054007-11929	192
051135-08710	138	051144-09142	70	054007-09917	189	054007-11930	192
051135-08730	138	051144-09143	70	054007-09931	189	054007-11932	191, 192
051135-08731	138	051144-09145	70	054007-09991	192	054007-11934	191, 192
051135-08740	138	051144-09146	70	054007-09998	192	054007-11935	191, 192
051135-08751	138	051144-09147	70	051144-10054	41	054007-11936	192
051135-08760	138	051144-09148	70	054007-10075	186	054007-11937	192
051135-08770	138	051144-09170	70	051111-10101	144	054007-11938	192
051135-08772	138	051144-09171	70	051111-10102	144	054007-11939	191, 192
051135-08796	143	051144-09172	70	051111-10103	144	054007-11940	192
051135-08875	143	051144-09173	70	051111-10111	144	054007-11943	192
051135-08876	143	051144-09176	70	051111-10112	144	054007-11959	192
051135-08877	143	051144-09205	70	051111-10113	144	054007-11960	191, 192
051135-08878	143	051144-09206	70	051111-10115	101	1260	164
051135-08879	135	051144-09207	70	051111-10116	101	1270	164
051135-08888	98	051144-09208	70	051111-10118	101	1271	164
051135-08898	143	054007-09230	190	051111-10120	101	1310	164
051135-08945	143	054007-09231	190	054007-10216	186	1311	164
051135-08946	143	021200-09292	69	051144-10240	41	051144-13323	60
051135-08983	97	051144-09305	70	051144-10242	41	051144-13325	60
051135-08984	98, 101, 135	051144-09307	70	051144-10260	41	051144-13627	67
051135-08986	98, 101, 135	051144-09308	70	051144-10261	41	048011-13702	101
051135-08987	98, 101, 135	051144-09310	70	051144-10270	41	048011-13722	180
051135-08991	133	051144-09312	70	051144-10273	41	048011-13723	180
051135-08992	133	051144-09314	70	051144-10288	41	054007-13760	187, 194
051135-08993	133	051144-09315	70	051144-10290	38	051144-13884	59
051144-09001	69	051144-09317	70	054007-10307	186	051144-13885	59
051144-09002	69	051131-09352	54	054007-10414	194	051144-13886	59
051144-09003	69	054007-09368	187	051144-10455	38	051144-13888	59
051144-09004	69	054007-09369	187	054007-10455	194	051144-13889	59
051131-09004	88, 91, 95	054007-09370	187	051144-10456	38	051135-13936	23
051144-09005	69	054007-09371	187	051144-10457	38	051135-13937	23
051131-09005	88, 96	054007-09372	187	051144-10458	38	051135-13938	23
051131-09006	88, 96	054007-09373	187	051144-10459	38	051135-13939	23
051131-09007	88, 96	054007-09374	187	051144-10460	38	051135-13940	23
051131-09009	88, 96	054007-09375	187	051144-10695	38	051135-13941	23
051131-09010	88, 96	054007-09376	187	051144-10697	38	051135-13942	23
051131-09011	88, 96	054007-09377	187	051144-10699	38	051135-13943	23
051131-09012	88, 96	054007-09378	187	054007-10810	186	051135-13944	23
051131-09018	89, 95	054007-09404	187	054007-10828	186	048011-14002	99
051131-09019	89, 95	051144-09410	71	054007-10836	186	051135-14003	14
051131-09020	89, 95	051144-09411	72	054007-10851	186	048011-14003	98
051131-09023	89, 96	051144-09413	72	051111-10954	71	051135-14004	14
051131-09026	88, 95	051144-09414	72	051111-10955	71	051135-14005	14
051131-09027	88, 95	051144-09415	71	1100	164	051135-14006	14
051131-09029	89, 96	051144-09416	71	054007-11000	192	051135-14007	14
051131-09030	89, 95	051144-09417	72	054007-11008	186	051135-14008	14
051131-09033	89, 96	051144-09418	72	1110	164	051135-14009	14
051131-09034	90, 97	054007-09423	187	1120	164	051135-14010	14

Part No.	Page No.	Part No.	Page No.	Part No.	Page No.	Part No.	Page No.
051135-14011	14	048011-18706	68	048011-19349	101	051144-21783	17
048011-14020	100	048011-18710	68	048011-19927	99	051144-21784	17
048011-14111	66	048011-18730	68	021200-19936	135	051144-21785	17
051144-14175	40	048011-18732	68	054007-20041	191	051144-21786	17
051144-14177	40	048011-18733	68	051144-20052	59	051144-21787	17
051144-14179	40	048011-18734	68	051144-20053	59	051144-21788	17
051144-14181	40	048011-18736	68	051144-20054	59	051144-21789	17
051144-14183	40	048011-18737	68	054007-20058	191	051144-21790	17
051144-14186	40	021200-18813	117	021200-20227	134	051144-21791	17
051144-14188	40	021200-18814	117	021200-20272	135	051144-21792	17
051144-14190	40	048011-19202	106	021200-20274	135	051144-21793	17
1425	165	048011-19211	106	048011-20529	181	051144-21794	17
1427	165	048011-19216	174	048011-20530	181	051144-21795	17
051144-14270	60	048011-19217	174	048011-20531	181	051144-21796	17
1435	164	048011-19218	174	048011-20535	181	051144-21797	17
1437	164	048011-19219	174	048011-20536	181	051144-21798	17
1440	165	048011-19220	174	048011-20540	181	051144-21799	17
1442	165	048011-19221	174	048011-20544	181	051144-21800	17
1450	165	048011-19223	174	048011-20545	181	051144-21923	19
021200-14557	122	048011-19224	174	048011-20546	181	054007-22203	192
021200-14558	122	048011-19235	174	048011-20550	181	054007-22211	192
051144-14661	59	048011-19236	174	048011-20551	181	054007-22880	191, 192
051144-14736	94	048011-19237	174	048011-20555	181	054007-22997	191, 192
021200-14765	117	048011-19238	174	048011-20559	181	054007-23094	192
021200-14766	117	048011-19239	174	048011-20560	181	054007-23128	192
054007-14853	190	048011-19249	174	048011-20561	181	054007-23136	192
054007-14861	191	048011-19250	174	048011-20565	181	048011-23162	64
054007-14879	191	048011-19251	174	048011-20566	181	048011-23163	64
048011-15027	64	048011-19278	174	048011-20570	181	048011-23322	181
051144-15287	36	048011-19279	174	048011-20583	181	048011-23357	106
051144-15288	36	048011-19280	174	048011-20584	181	048011-23360	106
051144-15289	36	048011-19281	174	048011-20585	181	048011-23387	181
051144-15290	36	048011-19282	174	048011-20589	181	048011-23413	181
051144-15299	36	048011-19283	174	048011-20590	181	048011-23414	181
051144-15300	36	048011-19284	174	048011-20594	181	048011-23415	181
051144-15301	36	048011-19285	174	048011-20639	181	048011-23416	181
051144-15302	36	048011-19288	174	048011-20640	181	048011-23417	181
054007-15652	192	048011-19289	174	048011-20641	181	048011-23418	181
054007-15660	192	048011-19290	174	048011-20642	181	048011-23419	181
054007-15678	192	048011-19292	175	048011-20688	64	048011-23420	181
051131-16000	105	048011-19293	175	2071	153	048011-23421	181
051131-16001	105	048011-19294	175	2076HF	153	048011-23430	181
051131-16019	105	048011-19296	175	2078	153	048011-23431	181
021200-16028	109	048011-19297	175	051144-20865	19	048011-23432	181
051131-16099	105	048011-19298	175	051144-20866	19	048011-23433	181
048011-16107	180	048011-19299	175	051144-20874	19	048011-23434	181
048011-16108	180	048011-19300	175	2091	149, 153	048011-23435	181
054007-16720	186	048011-19301	175	051144-20958	36	048011-23436	181
054007-16732	192	048011-19302	175	2096	153	048011-23437	181
054007-16734	192	048011-19303	175	051144-20961	36	048011-23438	181
054007-16736	194	048011-19304	175	051144-20962	36	048011-23448	181
048011-16861	101	048011-19305	175	2097	153	048011-23449	181
021200-16955	122	048011-19315	175	051144-20984	36	048011-23464	177
021200-17063	119	048011-19316	175	051144-20985	36	048011-23465	177
048011-17580	178, 180	048011-19317	175	051144-21027	36	048011-23466	177
048011-17584	178	048011-19318	175	051144-21037	36	048011-23468	177
048011-17635	180	048011-19319	175	021200-21180	135	048011-23469	177
048011-17636	180	048011-19320	175	021200-21181	135	048011-23470	177
048011-17780	178, 180	048011-19321	175	021200-21182	135	048011-23474	177
048011-17782	178	048011-19322	175	021200-21183	135	048011-23477	177
048011-17788	178, 180	048011-19323	175	021200-21210	137	048011-23478	177
048011-17790	178, 180	048011-19324	175	054007-21296	186	048011-23479	177
048011-17933	101	048011-19325	175	054007-21346	191	048011-23480	177
021200-18088	122	048011-19326	175	051144-21364	19	048011-23481	177
021200-18092	122	048011-19327	175	051144-21365	19	048011-23482	177
048011-18694	68	048011-19328	175	051144-21366	19	048011-23483	177
048011-18695	68	048011-19339	176	051144-21367	19	048011-23484	177
048011-18696	68	048011-19340	176	021200-21456	131	048011-23485	177
048011-18697	68	048011-19341	176	021200-21463	131	048011-23553	106
048011-18698	68	048011-19344	101	051144-21640	36	048011-23589	100

Part No.	Page No.	Part No.	Page No.	Part No.	Page No.	Part No.	Page No.
048011-23592	106	048011-26187	178, 180	048011-26493	178	051135-27726	183
048011-23593	106	048011-26188	180	048011-26495	178	051135-27727	183
048011-23649	100	048011-26189	178, 180	048011-26496	178	048011-28468	179
048011-23650	100	048011-26239	180	048011-26497	178	29026	172
048011-23651	100	048011-26240	180	048011-26515	179	048011-29211	66
048011-23652	100	048011-26242	180	048011-26516	179	048011-29212	66
048011-23748	181	048011-26243	180	048011-26518	179	048011-29213	66
048011-23749	181	048011-26246	180	048011-26519	179	048011-29214	66
048011-23750	181	048011-26269	180	048011-26520	179	048011-29217	66
048011-23763	181	048011-26272	180	048011-26521	179	048011-29218	66
048011-23764	181	048011-26273	180	051144-27421	45	048011-29219	66
048011-23766	181	048011-26275	180	051144-27422	45	048011-29220	66
048011-23767	181	048011-26276	180	051144-27423	45	048011-29221	66
048011-23768	181	048011-26291	179	051144-27425	45	048011-29222	66
048011-23769	181	048011-26293	179	051144-27426	45	048011-29462	179
048011-23770	181	051131-26330	108	051144-27428	45	048011-29463	179
048011-23771	181	051131-26332	108	051144-27458	45	048011-29464	179
048011-23772	181	051131-26334	108	051144-27459	45	048011-29465	179
048011-23773	181	051131-26335	108	051144-27460	45	048011-29466	179
048011-23774	181	051131-26336	108	051144-27461	45	048011-29467	179
048011-23788	181	051131-26338	108	051144-27462	45	048011-29469	179
048011-23789	181	051131-26340	108	051144-27463	45	048011-29470	179
048011-23790	181	051131-26341	108	051144-27464	45	048011-29471	179
048011-23791	181	051131-26343	108	051144-27465	45	048011-29472	179
048011-23793	181	051131-26344	108	051144-27466	45	048011-29473	179
048011-23794	181	051131-26346	108	051144-27467	45	048011-29474	179
048011-23795	181	048011-26417	174	051144-27468	45	048011-29476	179
048011-23796	181	048011-26418	174	051144-27469	45	048011-29477	179
048011-23797	181	048011-26419	174	051144-27470	45	048011-29566	180
048011-23798	181	048011-26431	178	051144-27471	45	021200-30023	137
021200-23824	121	048011-26432	178	051144-27472	45	021200-30026	137
048011-23874	177	048011-26433	178, 180	051144-27473	45	051128-30377	115
048011-23919	177	048011-26434	178	051144-27474	45	051128-30378	115
048011-23920	177	048011-26436	178, 180	051144-27475	45	051128-30379	115
054007-23920	192	048011-26437	178, 180	051144-27476	45	051131-31368	59
048011-23921	177	048011-26439	178, 180	051144-27477	45	051131-31407	59
048011-23922	177	048011-26440	178, 180	051144-27478	45	051131-31408	59
048011-23923	177	048011-26441	178, 180	051144-27479	45	051131-31434	16
048011-23924	177	048011-26442	178, 180	051144-27480	45	051131-31435	16
048011-23925	177	048011-26443	178, 180	051144-27481	45	051131-31438	16
048011-23926	177	048011-26444	178, 180	051144-27483	45	051131-31439	16
048011-23927	177	048011-26445	178, 180	051144-27485	45	051131-31440	16
048011-23928	177	048011-26446	178, 180	051144-27486	45	051131-31441	16
048011-23929	177	048011-26447	178, 180	051144-27487	45	051131-31442	16
048011-23930	177	048011-26448	178, 180	051144-27488	45	051131-31443	16
048011-23931	177	048011-26449	178, 180	051144-27489	45	051131-31501	16
048011-23932	177	048011-26450	178, 180	051144-27495	45	051131-31506	16
048011-23933	177	048011-26451	178, 180	051144-27496	45	051131-31547	17
048011-23934	177	048011-26452	178, 180	051144-27497	45	051131-31548	17
048011-23935	177	048011-26453	178, 180	051144-27498	45	051131-31549	16
048011-23941	177	048011-26454	178, 180	051144-27499	45	051131-31550	17
048011-23942	177	048011-26455	178, 180	051144-27500	45	051131-31551	17
048011-23943	177	048011-26456	178, 180	051144-27501	45	051131-31722	59
048011-23944	177	048011-26457	178, 180	048011-27603	68	051131-31724	59
054007-24035	192	048011-26458	178, 180	048011-27605	68	051131-31725	59
054007-24043	192	048011-26464	179	048011-27606	68	051131-31914	58
048011-25790	65	048011-26465	179	048011-27610	68	051131-31915	58
048011-25899	100	048011-26466	179	048011-27611	68	051131-31922	58
048011-25942	100	048011-26467	179	048011-27612	68	051131-31923	58
048011-25963	100	048011-26468	179	048011-27613	68	051131-31989	61
048011-25972	100	048011-26469	179	048011-27614	68	051131-31990	61
048011-26015	64	048011-26470	179	048011-27615	68	051131-32021	38
021200-26074	119	048011-26477	179	048011-27616	68	051131-32022	38
021200-26075	119	048011-26478	179	048011-27617	68	051131-32023	38
021200-26076	119	048011-26479	179	048011-27618	68	051131-32035	38
021200-26077	119	048011-26480	179	048011-27619	68	051131-32036	38
021200-26078	119	048011-26481	179	048011-27657	65	051131-32037	38
048011-26182	180	048011-26482	179	048011-27658	65	051131-32038	38
048011-26183	180	048011-26483	179	048011-27663	65	051131-32039	38
048011-26186	180	048011-26491	178	051135-27725	183	051131-32040	38



Part No.	Page No.	Part No.	Page No.	Part No.	Page No.	Part No.	Page No.
051131-32042	38	051131-37101	166	051131-38399	102	021200-49462	114
051131-32043	38	051131-37102	166	051135-38444	188	021200-49463	114
051131-32044	38	051131-37103	167	021200-39240	137	021200-49464	114
051131-32112	40	051131-37104	167	021200-39523	117	021200-49465	114
051131-32113	40	051131-37105	167	021200-39524	117	021200-49466	114
051131-32114	40	051138-37106	166	021200-41554	137	021200-49467	114
051131-32115	40	051138-37107	166	021200-41599	137	021200-49468	114
051131-32116	40	051131-37108	167	054007-42033	191	021200-49469	114
051131-32118	40	051131-37109	167	054007-42146	189	021200-49470	114
051131-32119	40	051131-37110	167	054007-42147	189	021200-49471	114
051131-32220	41	051131-37111	167	054007-42388	189	021200-49472	114
051131-32221	41	051131-37112	167	054007-42389	189	021200-49473	114
051131-32222	41	3720	163	054007-42390	189	021200-49474	114
051131-32230	32	051131-37711	103	054007-42391	189	021200-49475	114
051131-32231	32	051131-37716	90, 97, 102	021200-43793	136	021200-49476	114
051131-32232	32	051131-37717	103	021200-43797	136	021200-49477	114
051131-32498	44	051131-37718	105	021200-43798	136	021200-49478	114
051131-32541	40	051131-37720	105	021200-43799	136	021200-49479	114
051131-32544	40	051131-38050	103	021200-43813	136	021200-49480	114
051131-32545	40	051131-38051	103	021200-43814	136	054007-49517	187
054007-34457	189	051131-38052	103	051144-45091	66	054007-49518	187
054007-34458	189	051131-38070	103	051144-45092	66	054007-49519	187
054007-34459	189	051131-38071	103	051144-45095	66	051111-49536	19
054007-34460	189	051131-38072	103	051144-45096	66	051111-49537	19
054007-34461	189	051131-38073	103	051144-45101	66, 68	051111-49538	19
054007-34462	189	051131-38074	103	051144-45102	66, 68	051111-49539	19
048011-34501	179	051131-38075	103	051144-45189	20	051111-49540	19
048011-34556	179	051131-38076	103	051144-45190	60	49656	186
048011-34557	179	051131-38077	103	051144-45192	60	051144-49688	19
048011-34562	179	051131-38078	103	051144-45193	60	051144-49689	19
048011-34563	179	051131-38079	103	051144-45194	60	021200-49860	136
048011-34635	179	051131-38080	104	051144-45195	60	021200-49861	136
3500	163	051131-38081	104	051144-45196	60	021200-49862	136
3510	163	051131-38082	104	051144-45197	60	021200-49863	136
051131-35448	33	051131-38086	105	051144-45200	20	021200-49864	136
051131-35519	42	051131-38087	105	051144-45201	20	021200-49865	136
051131-35540	60	051131-38095	104	051144-45205	60	021200-49866	136
051131-35575	20	051131-38096	104	051144-45206	60	021200-49867	136
051131-35576	20	051131-38099	104	051144-45207	60	021200-49889	136
051131-35740	37	051131-38100	104	051144-45208	60	021200-49890	136
051131-35741	37	051131-38101	104	051131-45217	52	021200-49891	136
051131-35748	37	051131-38111	105	051131-45218	52	051131-50037	69
051131-35776	26	051131-38113	105	021200-45587	119	051131-50038	69
051135-36618	188	051131-38114	105	051131-46004	73	021200-50046	136
051135-36619	188	051131-38115	105	051131-46005	73	021200-50047	136
051135-36620	188	051131-38116	105	051131-46006	73	051131-50096	138
051135-36621	188	051131-38121	104	051131-46012	73	501	153, 154
051135-36622	188	051131-38122	104	051131-46013	73	502	153, 154
051135-36623	188	051131-38124	104	051131-46014	73	051131-50252	116
051135-36875	188	051131-38125	104	048011-46517	179	051131-50253	116
051135-36876	188	051131-38126	104	021200-48119	119	051131-50254	116
051135-36877	188	051131-38127	104	021200-49048	132	504	163
051135-36878	188	051131-38128	104	021200-49142	132	501111-50409	58
051135-36879	188	051131-38129	104	021200-49143	132	501111-50410	58
051135-36880	188	051131-38133	105	021200-49144	132	501111-50411	58
051135-36881	188	051131-38134	104	021200-49158	137	501111-50412	58
051135-36886	188	051131-38135	104	021200-49179	99	501111-50413	58
051135-36887	188	051131-38136	104	021200-49448	113	501111-50414	58
051135-36888	188	051131-38137	104	021200-49450	113	501111-50415	58
051135-36889	188	051131-38138	104	021200-49451	113	501111-50416	58
051135-36890	188	051131-38139	104	021200-49452	113	501111-50417	58
051135-36891	188	051131-38300	102	021200-49453	113	501111-50419	58
051135-36892	188	051131-38327	102	021200-49454	113	501111-50420	58
051135-36893	188	051131-38328	102	021200-49455	113	501111-50421	58
051135-36894	188	051131-38350	102	021200-49456	113	501111-50422	58
051131-37077	150	051131-38351	102	021200-49457	113	501111-50423	58
051131-37078	150	051131-38374	102	021200-49458	113	501111-50424	58
051131-37079	150	051131-38375	102	021200-49459	114	501111-50425	58
051131-37080	150, 154	051131-38377	102	021200-49460	114	501111-50426	58
051131-37100	166	051131-38378	102	021200-49461	114	501111-50427	58

Part No.	Page No.	Part No.	Page No.	Part No.	Page No.	Part No.	Page No.
501111-50428	58	021200-55461	115	021200-62539	140	7093B	154
501111-50429	58	051111-55713	23	021200-62543	140	021200-71177	119
501111-50430	58	051111-55714	23	021200-62544	140	021200-71179	119
501111-50432	58	051111-55716	23	021200-62545	140	021200-71180	119
501111-50433	58	051111-55717	23	021200-62549	140	021200-71182	119
501111-50434	58	051111-55718	23	021200-62550	140	021200-71450	195
501111-50435	58	051111-55719	23	021200-62551	140	7220T	100
051111-50440	62	051111-55720	23	021200-62552	140	7282	154
051111-50442	62	051111-55721	23	021200-62553	140	7283	154
051111-50443	62	051111-55722	23	021200-62554	140	7440	63
051111-50444	62	57650	168	021200-62558	140	7446	63
051111-50445	62	051131-58708	116	021200-62559	140	7449T	100
051111-50446	62	051131-58709	116	021200-62560	140	7456T	100
051111-50447	62	051131-58710	116	021200-62640	140	051128-74779	115
051111-50448	62	051131-58711	116	051131-62691	110	051128-74780	115
054007-50727	186	051131-58720	116	051131-62692	110	7501/37081	150
5101	149	051131-58721	116	051131-62693	110	7502/37082	150
051111-51045	62	051131-58722	116	6281	154	7503/37083	150
051111-51046	62	051131-58723	116	6282	154	7581	154
5106	149	051131-58724	116	6291/07002	151	7582	154
51645	168	051131-58725	116	6300/07026	150	7583	154
51911	149	051131-58726	116	6300DD	150	7586	154
51913	149	051131-58727	116	6391/07003	151	021200-76394	99
51P71	149	051131-58728	116	051135-64666	42, 196	021200-76418	98
5201	149	051131-58729	116	6472	99	021200-76546	98
5206	149	58830	168	6473	99	021200-76547	98
021200-52270	106	021200-59129	98	051131-65141	139	051144-76634	59
523-01-28	159	021200-59151	196	051131-65142	139	051131-76741	127
523-01-29	159	021200-59152	196	051131-65144	139	051138-76798	166
051131-52589	166	5N11	153	051131-65594	139	051138-76800	167
051131-52590	166	5P71	153	051131-65601	139	051138-76801	167
051131-52591	166	6001	152	051131-65987	139	051138-76802	167
051131-52592	166	6001ES	138	051131-65988	139	051138-76803	167
051131-52593	166	6002	152	051131-66206	139	051138-76804	167
051131-52595	166	6003	152	051131-66207	139	051138-76805	167
051131-52596	166	6004	152	051131-66208	139	051138-76806	167
529-04-48	159	6005	152	051131-66209	139	051138-76807	167
529-04-49	159	6006	152	051131-66313	139	051138-76808	166
529-04-50	159	021200-60572	111	6700	152	051138-76809	166
529-05-16	159	021200-60574	111	051131-67408	97, 100	051138-76810	166
529-05-17	159	021200-60596	111	021200-67424	75	051138-76811	166
529-05-18	159	021200-60597	111	021200-67432	75	051138-76812	166
529-05-19	159	021200-60600	111	051131-67442	168	051138-76813	166
529-05-20	159	054007-60825	194	051138-67533	183	051138-76814	166
529-05-21	159	60921	152	051138-67535	183	051138-76815	166
529-05-22	159	60922	152	051138-67537	183	051138-76816	166
529-05-23	159	60923	152	051138-67817	183	051138-76817	166
52911	149	60924	152	67P71	152	051138-76818	166
52913	149	60925	152	6800	152	051138-76819	166
52P71	149	60926	152	6878	154	051138-76820	166
5301	149	60929	152	6885	154	051131-76831	166
055128-53042	115	6100/07024	150	6886	154	051131-77384	127
5306	149	6100DD	150	6889	154	051131-77385	127
051128-53460	115	021200-61173	110	6892	154	051131-77399	125
051128-53593	193	021200-61174	110	6893	154	051131-77400	125
051128-53594	193	021200-61176	110	6894	154	051131-77401	125
051128-53595	193	021200-61177	110	6895	154	051131-77402	125
051128-53596	193	021200-61192	109	6897	154	051131-77403	125
051128-53597	193	6191/07001	151	6898	154	051131-77406	126
051128-53598	193	6200/07025	150	6899	154	051131-77407	126
051128-53599	193	6200DD	150	68P71	152	051144-77752	26
051128-53600	193	021200-62013	195	6900	152	051144-77855	26
051128-53601	193	021200-62014	195	69P71	152	051144-77856	57
051128-53604	193	021200-62225	195	051131-70532	139	7800S-L	152
53911	149	021200-62334	110	051131-70533	139	7800S-M	152
53913	149	021200-62335	110	051131-70534	139	7800S-S	152
53P71	149	021200-62535	140	051131-70535	139	7881S	154
021200-55458	115	021200-62536	140	051131-70536	139	7882	154
021200-55459	115	021200-62537	140	051131-70537	139	7883	154
021200-55460	115	021200-62538	140	7093	154	7884	154

Part No.	Page No.	Part No.	Page No.	Part No.	Page No.	Part No.	Page No.
7885	154	051144-81730	60	021200-86246	140	051131-88619	183
7887	154	051144-81731	60	021200-86247	140	051131-88622	183
7890	161	051144-81732	60	021200-86248	140	051131-88624	183
7893S	154	051144-81733	60	021200-86249	140	051144-88700	51
7894	154	051144-81734	60	021200-86250	140	051144-88701	51
7895	154	051144-81735	60	021200-86251	140	051144-88702	51
7899-100	154	8210	146	021200-86252	140	051144-88703	51
7899-25	154	8211	146	021200-86253	140	051144-88704	51
7914	154	8212	148	021200-86254	140	051144-88705	51
7915-5	154	8214	148	021200-86255	140	051144-88706	51
051131-79283	127	051144-82189	20	021200-86256	140	051144-88707	51
051131-79284	126	051131-82238	61	021200-86277	141	051144-88743	60
051131-79713	139	021200-82242	137	021200-86278	141	051144-88763	62
051131-79748	110	8233	147	021200-86279	141	051144-88764	62
051131-79749	110	8242	99	021200-86285	140	051144-88765	62
051131-79750	110	8246	147	021200-86286	140	051144-88766	62
7981S	154	051144-82460	15	051144-86299	24	051144-88769	62
7986	154	051144-82461	15	051144-86300	24	051144-88901	19
7989	154	051144-82463	15	021200-86309	141	051144-88902	19
7990	154	051144-82464	15	021200-86416	75	051144-88903	19
7991	154	051144-82465	15	021200-86417	75	051144-88904	19
7992	154	051144-82466	15	021200-86422	75	051144-88905	19
7993	154	051144-82467	15	021200-86423	75	051144-88906	19
7999	154	051144-82468	15	051144-86468	17	9021	100
051131-80040	168	051144-82469	15	051144-86469	17	9021CS	100
051131-80041	168	8247	147	051144-86470	17	9210	146
051131-80052	127	051144-82470	15	051144-86471	17	9211	146
051131-80053	127	051144-82471	15	051144-86472	17		
051131-80054	127	051131-82659	57	051144-86473	17		
051131-80055	127	8271	146	051144-86474	17		
051131-80056	127	021200-82862	117	051144-86475	17		
051131-80058	127	021200-82863	117	051144-86476	17		
051144-80512	59	021200-82864	117	051144-86477	17		
051144-80513	59	021200-82865	117	051144-86478	51		
051144-80514	60	8293	147	051144-86479	51		
051144-80515	60	051144-83411	27	051144-86480	51		
051144-80516	60	051144-83417	27	051144-86481	51		
051144-80517	60	051144-83421	27	051144-86482	51		
051131-80988	110	051144-83497	35	051144-86483	51		
8110S	146	051144-83678	15	051144-86484	51		
051144-81368	59	051144-83679	15	051144-86485	51		
051144-81376	59	051144-83680	15	051144-86486	51		
051144-81393	45	051144-83681	15	051144-86487	51		
051144-81394	45	021200-83949	75	051144-86488	17		
051144-81395	45	021200-83950	75	051144-86489	17		
051144-81396	45	051144-83978	35	051144-86490	17		
051144-81397	45	8440	99	051144-86491	17		
051144-81398	45	051144-84753	15	051144-86492	17		
051144-81399	45	051144-84754	27	051144-86493	17		
051144-81400	45	051131-85088	22	051144-86494	17		
051144-81401	45	051144-85097	66	051144-86495	17		
051144-81402	45	8511	146	051144-86496	17		
051144-81403	45	8512	148	051144-86497	17		
051144-81404	45	8514	148	051144-86498	51		
051144-81410	45	8515	148	051144-86499	51		
051144-81411	45	8541	100	021200-86518	118		
051144-81412	45	8550	100	021200-86519	118		
051144-81413	45	8576	147	8651ES	169		
051144-81414	45	8577	147	021200-86520	118		
051144-81415	45	021200-85822	143	021200-86523	118		
051144-81429	45	021200-85851	120	021200-86524	118		
051144-81430	45	021200-86229	141	021200-86525	118		
051144-81431	45	021200-86230	141	8652ES	169		
051144-81432	45	021200-86239	140	8654ES	169		
051144-81433	45	021200-86240	140	8656ES	169		
051144-81434	45	021200-86241	140	8658ES	169		
051144-81470	94	021200-86242	140	8660ES	169		
051144-81471	94	021200-86243	140	021200-87998	137		
051144-81728	60	021200-86244	140	88044	35		
051144-81729	60	021200-86245	140	051131-88418	183		

## 3M International Branch Locations

### Argentina

Diego Meiriño  
3M Argentina S.A.C.I.F.I.A.  
Los Arboles 842 1686 - Hurlingham  
Provincia de Buenos Aires  
Phone: 54-1-662-6000  
Fax: 54-1-665-4071

### Australia

Steven Perez  
3M Australia Pty., Ltd.  
950 Pacific Highway  
Pymble, N.S.W. 2073  
Phone: 61-2-498-9333  
Fax: 61-2-498-9666

### Brazil

Waldyr Bevilacqua Jr.  
3M DO Brasil Ltda.  
Via Anhanguera, km 110  
13177-070 - Sumare  
Sao Paulo, Brasil  
Phone: 55-192-864-7000  
Fax: 55-192-864-1206

### Canada

Andrew Spencer  
3M Canada Company  
300 Tartan Drive  
London, Ontario, Canada N5V4M9  
Phone: 519-452-6141  
Fax: 519-659-5392  
Toll Free 1-800-265-1840 ext. 6141

### Caribbean Region

Jorge Aguilo  
3M Puerto Rico, Inc.  
P.R. Industrial Park  
Ave. 65 Infanteria km. 12.6  
Lote #6, 7  
Carolina, Puerto Rico 00985  
Phone: 787-750-3000  
Fax: 787-750-3035

### China Region

Henry M. Wong  
3M China Limited  
General Office  
10/F, New Town Mansion  
55 Loushanguan Road  
Shanghai 200335 China  
Phone: 86-21-6275-3535  
Fax: 86-21-6275-2343

### Colombia

Gustavo Sotelo  
3M Columbia S.A.  
Apartado Aereo 11091  
Avenida El Dorado No. 78A93  
Bogota, Colombia  
Phone: 57-1-416-1666  
Fax: 57-1-416-1677

### Croatia

Tomislav Slat  
Buzanova 2  
10 000 Zagreb  
Croatia  
Phone: 00-385-12361502

### Denmark

Svend Larson  
Post Boks 1393  
Fabriksparken 15  
DK-2600 Glostrup  
Denmark  
Phone: 45-4348-2100

### Europe

Mark Gates  
3M House, P.O. Box 1  
Market Place, Bracknell, Berkshire  
RG12 1JU England  
Phone: 44-1344-858000  
Fax: 44-1344-858295

### Finland

Jouni Seppanen  
P.O. Box 90  
02601 Espoo  
Finland  
Phone: 358-9-5252592

### France

Pierre Mader  
3M France, Boulevard de l'oise  
F-95006 Cergy-Pontoise Cedex  
Phone: 33-1-30-31-6215  
Fax: 33-1-30-31-7064

### Germany

Werner Bibl  
3M Germany  
CarlSchurz-Strasse  
D41453 Neuss  
Germany  
Phone: 49-209-590-8308

### Greece

Panos Tsakos  
3M Hellas, Ltd, 20 Kifissias Ave.  
151 25 Paradissos.Maroussi - Athens  
Phone: 30-1-6842-902  
Fax: 30-1-6843-281

### Gulf Region

Husam Abdelghani  
Hamrain Centre  
4th Floor  
Alwahda Street  
P.O. Box 20191  
Dubai, UAE  
Phone: 9661-4790555

### Italy

Angelo Fossati  
P.O. Box 10411-10412  
Via s.Bovio, 3  
20090 Loc.S.Felice Di  
Segrate  
Milan  
Phone: 3902-7035-2286

### Japan

H. Hasebe (Sumitomo)  
33-1, Tamagawadai 2-chome  
Setagaya-ku, Tokoyo 158 Japan  
Phone: 81-3-3709-8111  
Fax: 81-3-3709-8746

### Korea

C. S. Eo  
11th Floor Life Building  
#61, Yoldo-dong, Yondungpo-Ku  
Seoul 150-010, Korea  
Phone: 82-2-3771-4114  
Fax: 82-2-785-2923

### Mexico

Ariel Correa Gomez  
3M Mexico/Riker S.A. de C.V.  
Calz, San Juan De Aragon 516  
Col. Carrera Lardizabel  
Del. Gustavo A. Madero  
Mexico, D.F. 07070 Mexico  
Phone: 52-5-626-0400  
Fax: 52-5-728-2299

### Netherlands

Arnold Kroon  
Industrieweg 24  
2382 NW Zoeterwoude  
P.O. Box 193  
2300 AD Leiden  
The Netherlands  
Phone: 3131-854-3094

### New Zealand

Chris Brereton  
3M New Zealand Ltd.  
250 Archers Road  
Glenfield, Auckland, New Zealand  
Phone: 64-9-444-4760  
Fax: 64-9-444-2773

### Norway

Lars Halvorsen  
P.O. Box 100  
N-2013 Skjetten  
Norway  
Phone: 47-6384-2500

### Singapore

Bee Khoon Ng  
3M Singapore  
9, Tagore Lane Singapore 2678  
Republic of Singapore  
Phone: 65-45-48611  
Fax: 65-45-85432

### South Africa

Kenneth Chiochetti  
3M South Africa  
3M South Africa (Pty.) Ltd  
181 Barbara Road  
Elandsfontein, 1406  
Republic of South Africa  
Phone: 27-11-922-9111  
Fax: 27-11-922-2271

### Spain

Francisco Mercader  
3M Espana CA  
Calle Juan Ignaci  
Luca de Tena 19-25  
28027 Madrid  
Spain  
Phone: 34-91-321-6217

### Sweden

Christina N. Anderssen  
Bollstanasvagen 3  
SE 191.89 Sollentuna  
Saffans Vag 4  
Sweden  
Phone: 46-8-92-2222

### Taiwan

Rosa Wen  
3M Taiwan Limited  
13th Floor, Lotus Building  
136 Sec 3, Jen Ai Rd.  
Taipei 10628, Taiwan, R.O.C.  
Phone: 886-2-704-9011  
Fax: 886-2-706-0383

### Trinidad & Tobago

Glenda de Silva  
3M InterAmerica, Inc.  
P.O. Box 1296, Port of Spain  
Trinidad WI  
Phone: 809-623-8917  
Fax: 809-623-3079

### Turkey

Selim Birsen  
Nisbetiye Cad.Akmerkez  
Blik 3 Kat: 6 Etiler  
80600 Istanbul  
Turkey  
Phone: 90-212-282-2382

### United Kingdom/Ireland

Peter Furby & Colin Ridout  
3M United Kingdom plc  
3M House, P.O. Box 1  
Market Place, Bracknell, Berkshire  
RG12 1JU England  
Phone: 44-1344-858000  
Fax: 44-1344-858295

### Venezuela

Miguel Fuentes  
3M Manufacturera Venezuela S.A.  
Puente Brion a Luis Razetti  
Edif, 3M  
La Candelaria, Caracas 1010-A  
Phone: 58-2-508-8111  
Fax: 58-2-5740910

### All Other International Inquiries

3M Marine Trades  
3M Center - Bldg. 223-6S-06  
St. Paul, MN 55144-1000 U.S.A.  
Phone: 651-736-7988  
Fax: 651-737-9658

### 3M Branch Offices

#### Alaska

11151 Calaska Circle  
Anchorage, Alaska 99515  
Telephone (907) 522-5200  
Fax (907) 522-1645

#### Atlanta

2860 Bankers Industrial Drive  
Atlanta, Georgia 30360  
Telephone 1-800-771-7049  
Fax 1-800-699-7840

#### Hawaii

4443 Malaai Circle  
Mail to: P.O. Box 30048  
Honolulu, Hawaii 96818  
Telephone (808) 422-2721  
Fax (808) 422-9557

#### Los Angeles

10330 Pioneer Boulevard, Suite 210  
Santa Fe Springs, California 90670-8276  
Telephone 1-800-865-6744  
Fax 1-800-648-0871

#### For Further Information

1-877-3M-Marine (1-877-366-2746)

#### Internet

[www.3m.com/marine](http://www.3m.com/marine)

Alba	877-251-9046	575-9588	jaalba@mmm.com
Axell	888-847-7856	575-9687	jaaxell@mmm.com
Boyd	800-965-2648	575-7385	rmboyd@mmm.com
Brown	800-965-3021	575-7395	pebrown@mmm.com
Christenson	800-965-2652	575-7386	jlchristenson@mmm.com
Clagett	888-400-5172	575-9552	jdclagett@mmm.com
DeMeester	800-965-2951	575-7393	rademeester1@mmm.com
DeStefano	877-318-1883	575-9657	adestefano@mmm.com
Gonzalez	800-965-2945	575-7390	lfgonzalez@mmm.com
Gooch	800-940-1384	575-9133	jrgooch@mmm.com
Harvey	800-965-3025	575-7397	jmharvey@mmm.com
Lamers	888-400-5173	575-9553	sclamers@mmm.com
Losch	800-965-2946	575-7391	dlosch@mmm.com
Lyerla	800-965-2942	575-7389	plyerla@mmm.com
Martens	888-400-1429	575-9262	mlmartens@mmm.com
Martin	800-965-2953	575-7394	jfmartin@mmm.com
McLellan	800-965-2641	575-7383	mamclellan@mmm.com
Morrill	877-566-4044	575-8333	camorrill@mmm.com
Royster	800-965-3023	575-7396	eroyster1@mmm.com
Sprout	800-965-7038	575-7402	jksprout@mmm.com
Srb	800-965-2949	575-7392	bsrb@mmm.com
Wall	800-949-8087	575-2409	jfwall@mmm.com
Winke	888-400-5171	575-9551	bmwinke@mmm.com
Wolfe	800-965-6885	575-7398	jwwolfe@mmm.com
Zielinski	877-318-1881	575-9659	mjzielinski@mmm.com



#### Marine

3M Center, Building 223-6S-06  
St. Paul, MN 55144-1000



Minimum 10%  
Post-Consumer Fiber

Cover art by Bruce A. Alderson,

© 3M 2002 60-4400-9000-3