

Twin Over Twin Bunk Bed with Storage
Lit Superposé avec Rangement

HU10395

USA office: Fontana AUS office: Truganina GBR office: Ipswich FRA office: Saint Vigor d'Ymonville

If you're having difficulty, our friendly customer team is always here to help.



USA: cs.us@costway.com
AUS: cs.au@costway.com
GBR: cs.uk@costway.com
FR A: cs.fr@costway.com

THIS INSTRUCTION BOOKLET CONTAINS **IMPORTANT** SAFETY INFORMATION. PLEASE READ AND KEEP FOR FUTURE REFERENCE.

EN



Before You Start

- ⚠ Please read all instruction carefully.
- ⚠ Retain instructions for future reference.
- ⚠ Separate and count all parts and hardware.
- ⚠ Read through each step carefully and follow the proper order.
- ⚠ We recommend that, where possible, all items are assembled near to the area in which they will be placed in use, to avoid moving the product unnecessarily once assembled.
- ⚠ Always place the product on a flat, steady and stable surface.
- ⚠ Keep all small parts and packaging materials for this product away from babies and children as they potentially pose a serious choking hazard.

FR



Avant de Commencer

- ⚠ Veuillez lire attentivement toutes les instructions.
- ⚠ Conservez les instructions pour vous y référer ultérieurement.
- ⚠ Vérifiez toutes les pièces et les accessoires.
- ⚠ Lisez attentivement chaque étape et suivez l'ordre correct.
- ⚠ Nous recommandons que, dans la mesure du possible, tous les produits soient assemblés à proximité de la zone où ils seront utilisés, afin d'éviter tout déplacement inutile du produit une fois assemblé.
- ⚠ Placez toujours le produit sur une surface plane et stable.
- ⚠ Conservez toutes les petites pièces de ce produit et les matériaux d'emballage hors de portée des bébés et des enfants, car ils pourraient présenter un risque d'étouffement.

EN



Return / Damage Claim Instructions

- ⚠ **DO NOT** discard the box / original packaging.
In case a return is required, the item must be returned in original box. Without this your return will not be accepted.
- ⚠ Take a photo of the box markings.
A photo of the markings (text) on the side of the box is required in case a part is needed for replacement. This helps our staff identify your product number to ensure you receive the correct parts.
- ⚠ Take a photo of the damaged part (if applicable).
A photo of the damage is always required to file a claim and get your replacement or refund processed quickly. Please make sure you have the box even if it is damaged.
- ⚠ Send us an email with the images requested.
Email us directly from marketplace where your item was purchased with the attached images and a description of your claim.

FR



Instructions De Retour / Réclamation De Dommages

- ⚠ **NE PAS jeter la boîte/l'emballage d'origine.**
Dans le cas où un retour est requis, l'article doit être retourné dans sa boîte d'origine. Sans cela, votre retour ne sera pas accepté.
- ⚠ **Prenez une photo des marquages de la boîte.**
Une photo des marquages (texte) sur le côté de la boîte est requise au cas où une pièce serait nécessaire pour le remplacement. Cela aide notre personnel à identifier votre numéro de produit pour s'assurer que vous recevez les bonnes pièces.
- ⚠ **Prenez une photo des dommages (le cas échéant).**
Une photo des dommages est toujours requise pour déposer une réclamation et obtenir rapidement votre remplacement ou votre remboursement. Assurez-vous d'avoir la boîte même si elle est endommagée.
- ⚠ **Envoyez-nous un e-mail avec les images demandées.**
Envoyez-nous un e-mail directement depuis le marché où votre article a été acheté avec les images ci-jointes et une description de votre réclamation.

Detail View / Vue Détaillée

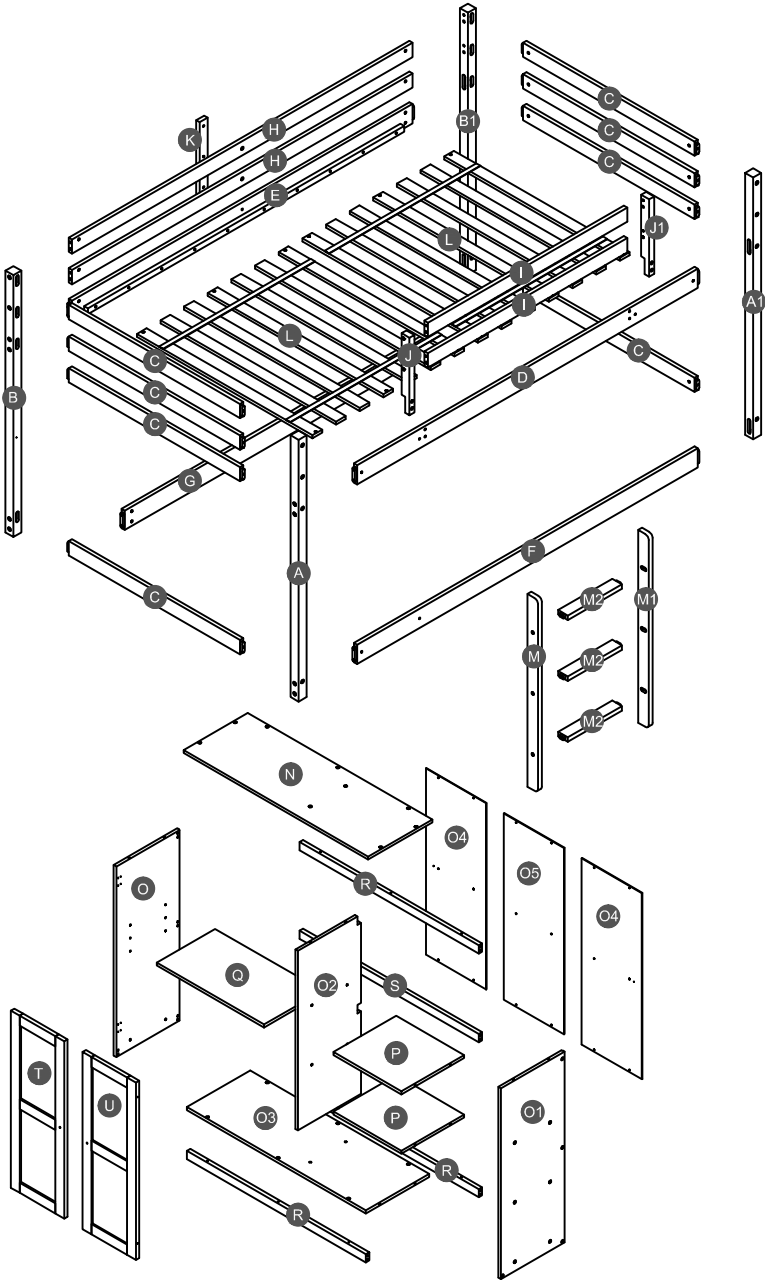
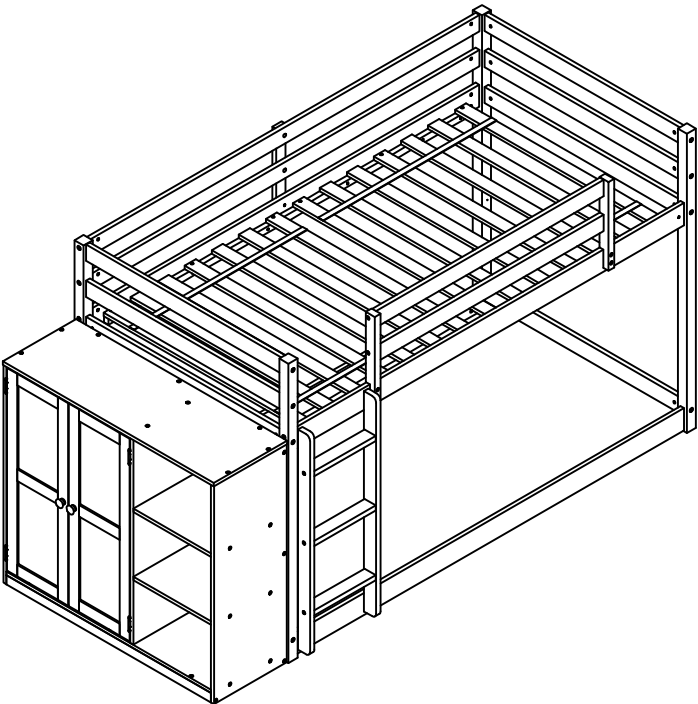

Part List / Liste des Pièces

HU10395-12

A x1

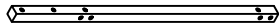

Leg (Left Front)
/Pied (avant gauche)

A1 x1

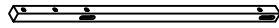

Leg (Right Front)
/Pied (avant droit)

B x1

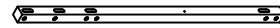

Leg (Left Back)
/Pied (arrière gauche)

B1 x1



Leg (Right Back)
/Pied (arrière droit)

C x8



Horizontal bar
/ Barre horizontale

D x1



Upper Side rail (Front)
/Supérieur Rail latéral (Avant)

E x1



Upper Side rail (Back)
/Supérieur Rail latéral (Arrière)

F x1

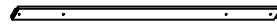

Lower Side rail (Front)
/Inférieure Rail latéral (Avant)

G x1



Lower Side rail (Back)
/Inférieure Rail latéral (Arrière)

H x2



Long guard rail (Back)
Garde-corps long (arrière)

I x2



Short guard rail (Front)
Garde-corps court (avant)

J x1



Left support guard rail
Garde-corps de support gauche

J1 x1



Right support guard rail
Garde-corps de support droit

K x1



Vertical guard rail
Garde-corps vertical

L x2

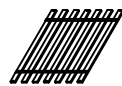

Slats - 2set (7pcs/set)
Lattes - 2set (7pcs/set)

M x1



Ladder (Left)
Échelle (gauche)

M1 x1



Ladder (Right)
Échelle (droit)

M2 x3



Step ladder
Escabeau

16:

13 	15
x4	x2

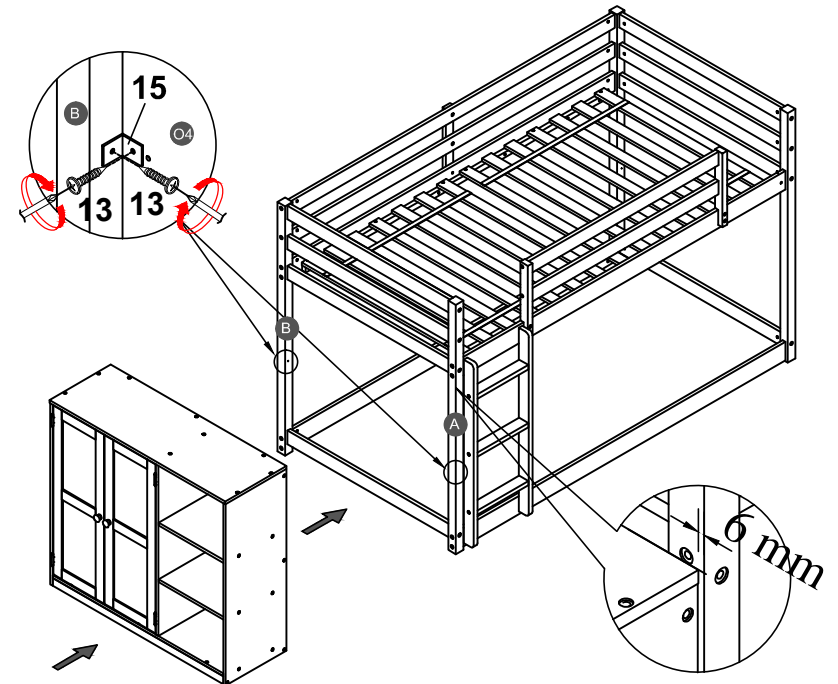

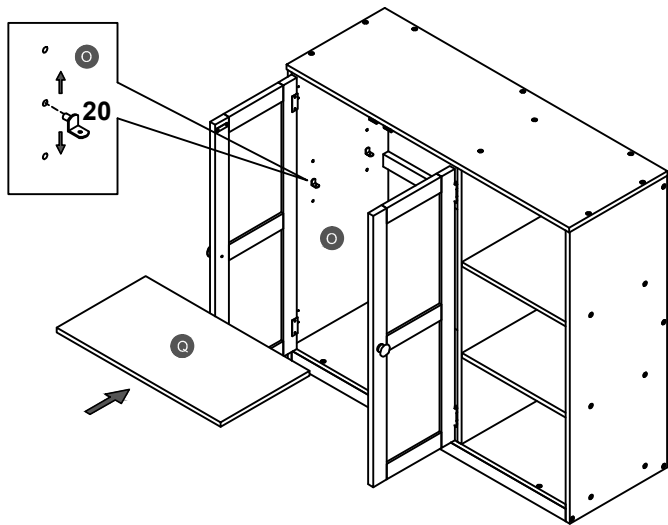
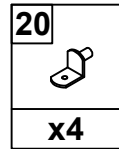

HU10395-22

N x1

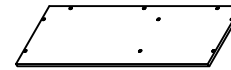

Top panel
/Panneau supérieur

O x1

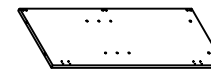

Left side panel
/Panneau latéral gauche

O1 x1

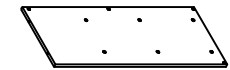

Right side panel
/Panneau latéral droit

O2 x1



Divider panel
/Panneau de séparation

O3 x1

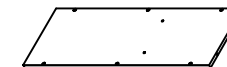

Bottom panel
/Panneau de fond

O4 x2

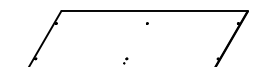

Back panel
/Panneau arrière

O5 x1



Back panel
/Panneau arrière

P x2



Shelf panel
/Panneau d'étagère

Q x1



Shelf panel
/Panneau d'étagère

R x3



Horizontal bar
/ Barre horizontale

S x1

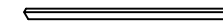

Horizontal bar
/ Barre horizontale

T x1



Door (Left)
/Porte (Gauche)















U x1



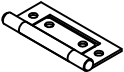

Door (Right)
/Porte (Droite)

Hardware List / Liste des Accessoires

HU10395-12

1 x8 	2 x20 	3 x20 
Ø8*30mm	(Ø15)1/4"*100mm	(Ø15)1/4"*80mm
Wood dowel /Cheville en bois	Hex-Head bolts /Boulons à tête hexagonale	Hex-Head bolts /Boulons à tête hexagonale
4 x34 	5 x4 	6 x3 
(Ø12)1/4"*60mm	(Ø12)1/4"*35mm	(Ø12)1/4"*30mm
Hex-Head bolts /Boulons à tête hexagonale	Hex-Head bolts /Boulons à tête hexagonale	Hex-Head bolts /Boulons à tête hexagonale
7 x74 	8 x9 	9 x1 
1/4"*15 (9.5mm)	(Ø12)1/4"*40mm	(1/4")4.5*58mm
Horizontal-Hole bolts /Boulons à trous horizontal	Hex-Head bolts /Boulons à tête hexagonale	Allen key /Clé Allen
10 x4 	11 x1 	12 x14 
55*25*1.3mm	140*33*19mm	Ø4*30mm
Hinges /Charnières	Stopper door /Butée de porte	Screws / Vis
13 x22 	14 x4 	15 x2 
Ø3.5*15mm	(Ø12)1/4"*40mm	24*28*28*2mm
Screws / Vis	Hex-Head bolts /Boulons à tête hexagonale	Metal bracket /Support métallique





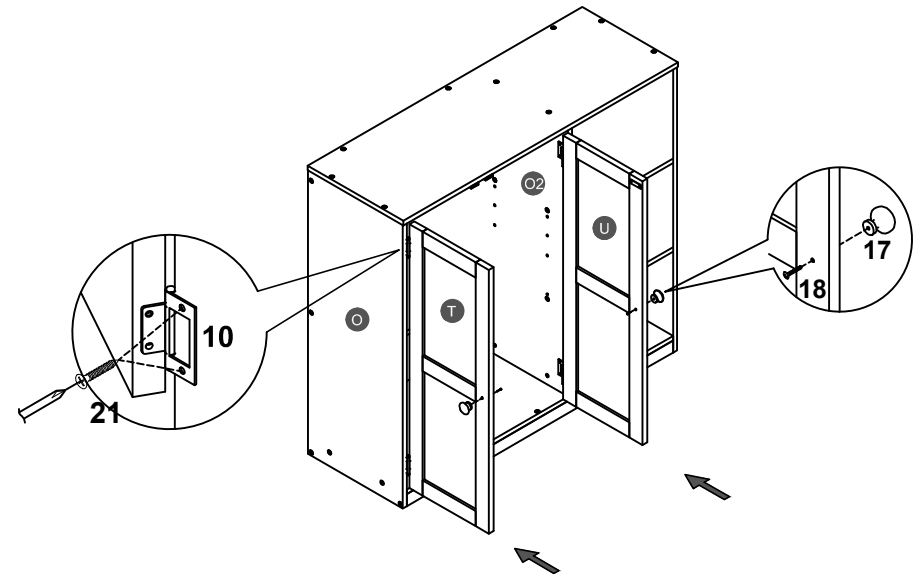

14:

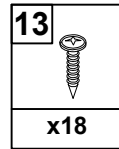
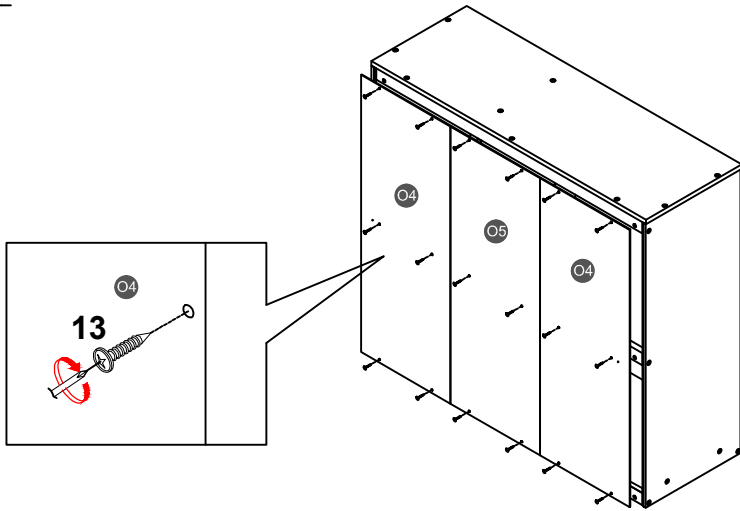
18 	17 	21 
x2	x2	x8



12:



16 x8 	17 x2 	18 x2 
Ø10*40mm	Ø38*Ø28*33mm	3/16"*30mm
Wood dowel /Cheville en bois	Knob /Bouton	Bolt (for Knob)/ Boulon (pour le bouton)
19 x2 	20 x4 	21 x20 
45*12*1.5mm	30*14*1.5mm	Ø3*15mm
Metal magnet /Aimant métallique	Shelf pin /Goupille d'étagère	Screws / Vis
22 x1 		
Ø10*20mm		
Wood dowel /Cheville en bois		

13:

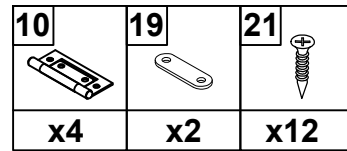
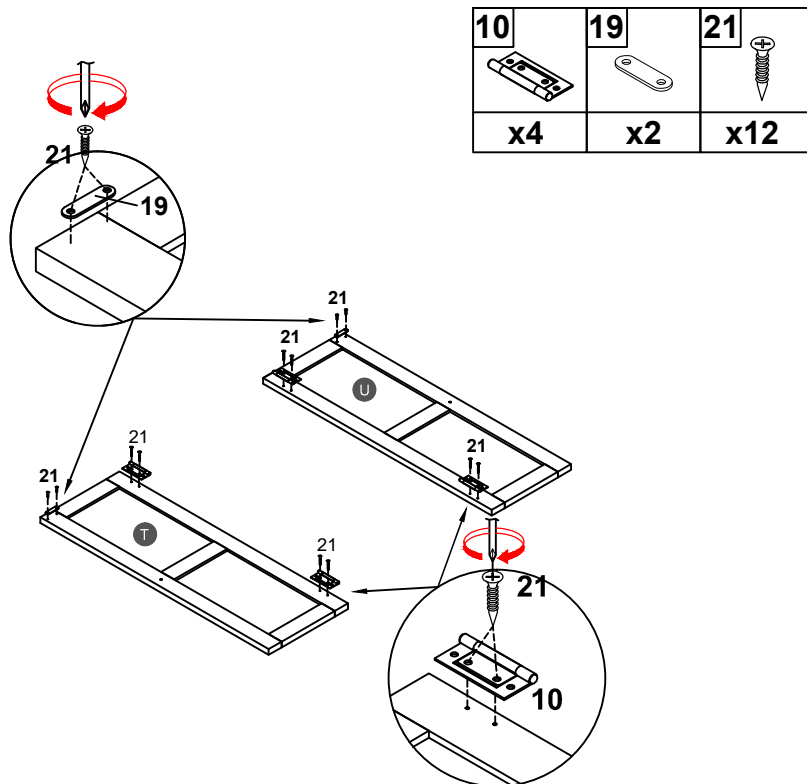

EN: ASSEMBLY TOOLS REQUIRED (NOT INCLUDED)

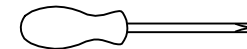

FR: OUTILS D'ASSEMBLAGE REQUIS (NON INCLUS)



EN: PLEASE BE CAREFUL DO NOT DAMAGE THE HOLE POSITION WHEN YOU USE POWER TOOLS !

FR: VEUILLEZ FAIRE ATTENTION À NE PAS ENDOMMAGER LA POSITION DU TROU LORSQUE VOUS UTILISEZ DES OUTILS ÉLECTRIQUES !

01:

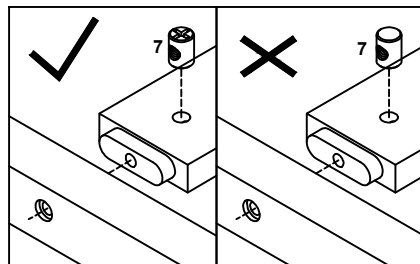
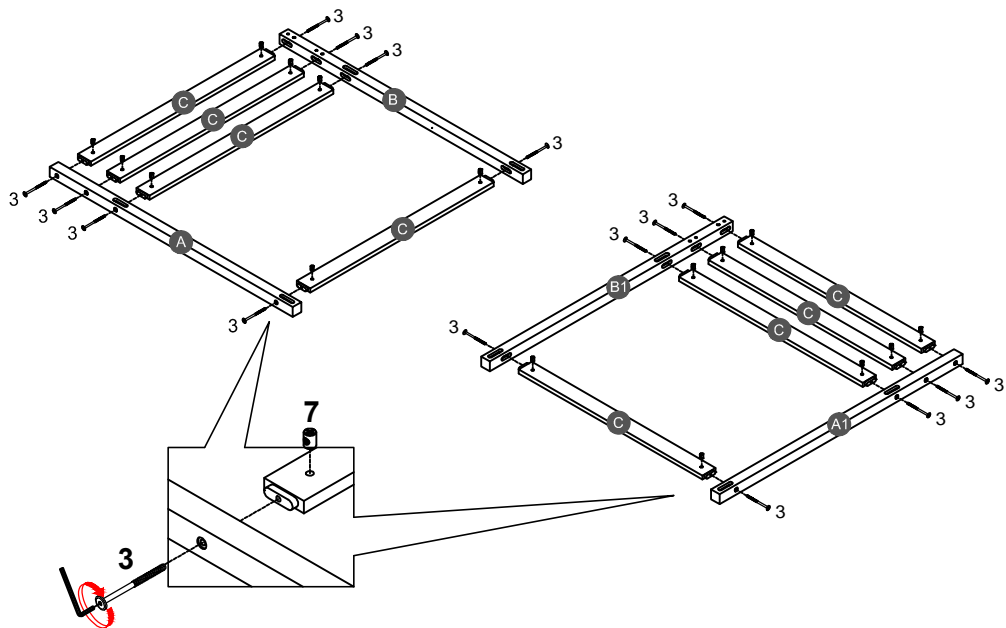

3	7
	
x16	x16



EN: Note: Part 7 will face up with the "x" mark on it, otherwise it cannot be tightened.



FR: Remarque: La pièce 7 sera face vers le haut avec la marque <<x>>, sinon elle ne peut pas être serrée.

11:

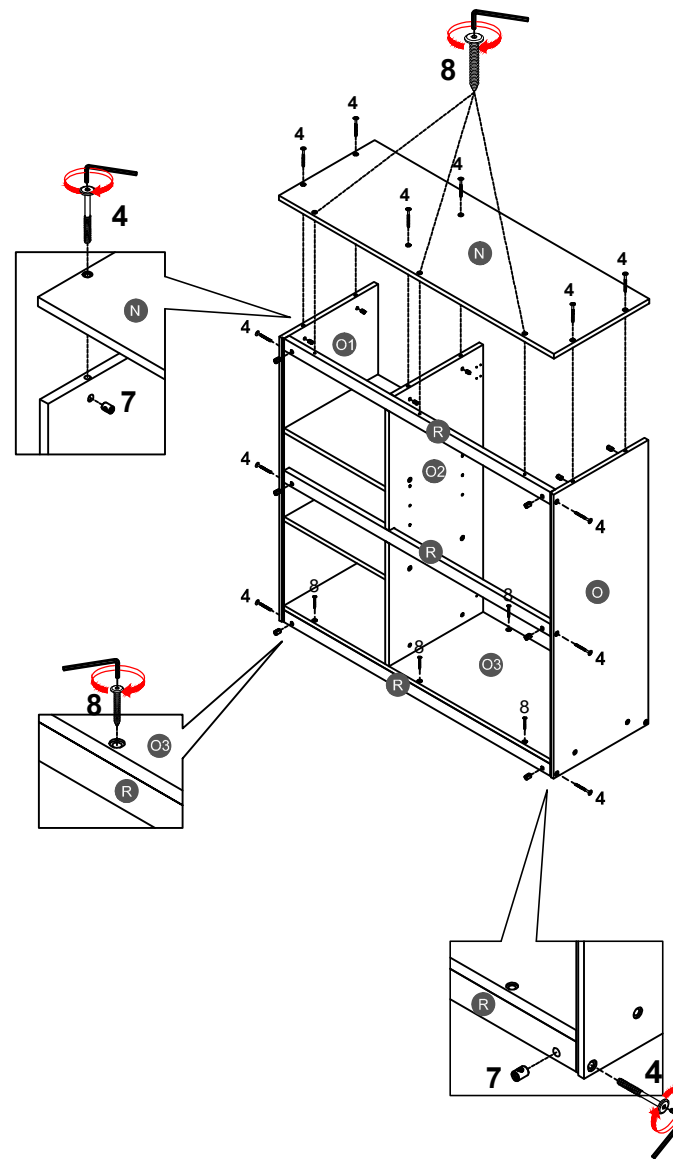
4	7
	
x12	x12
	8
	
	x9



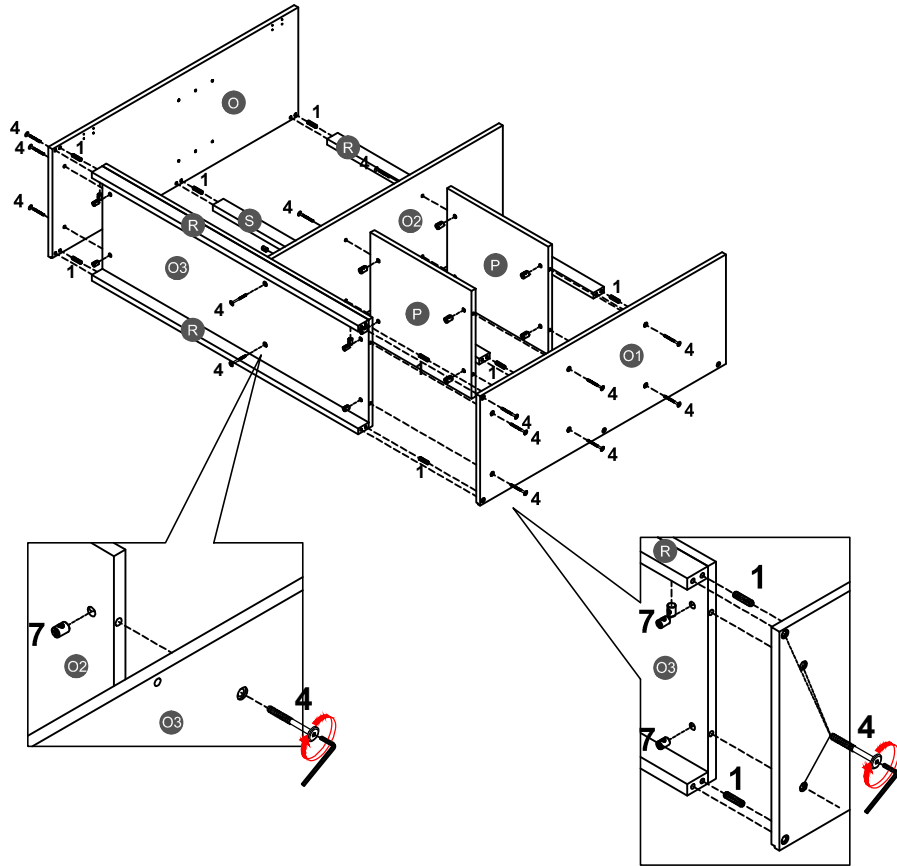

10:

1		4		7	
	x8		x16		x16



02:

2		7	
	x20		x20
		16	
			x4

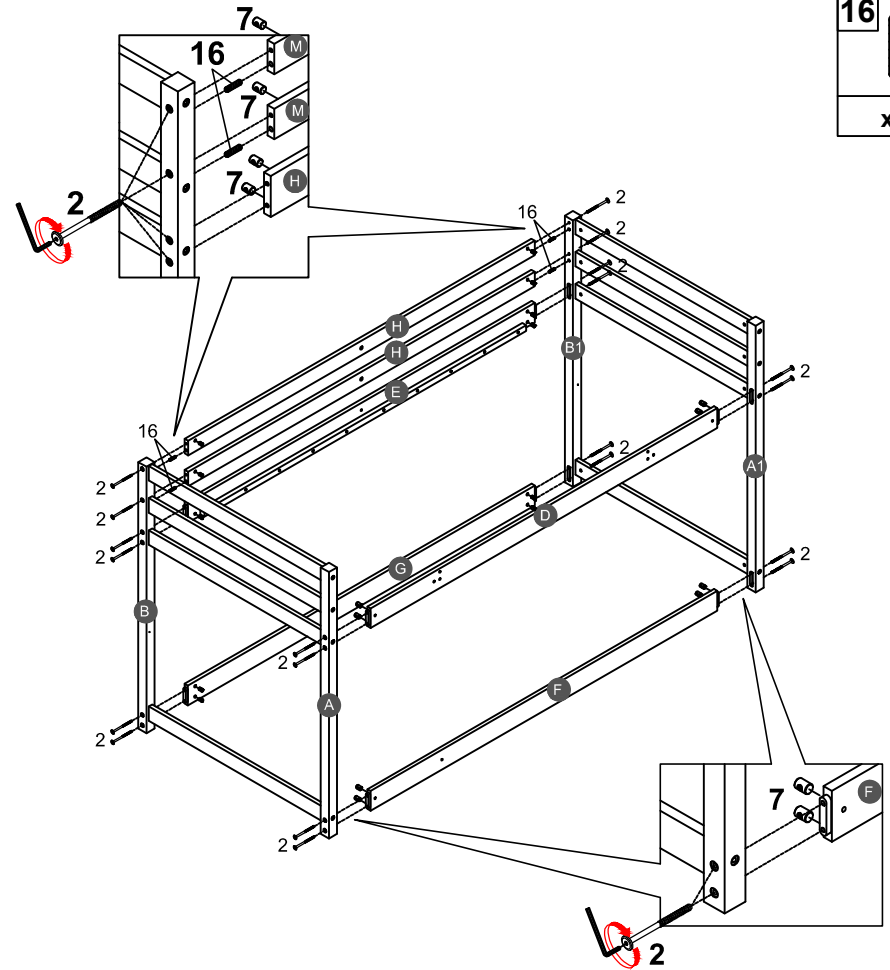

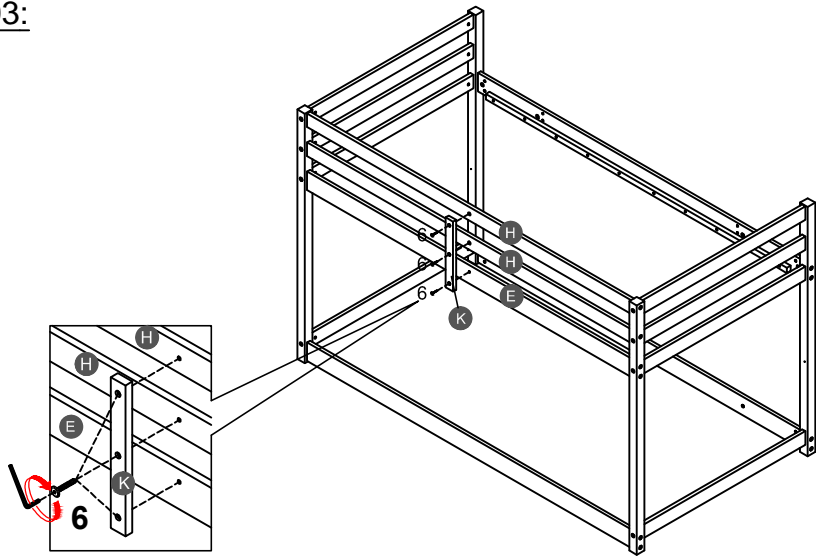

03:

6	
x3	



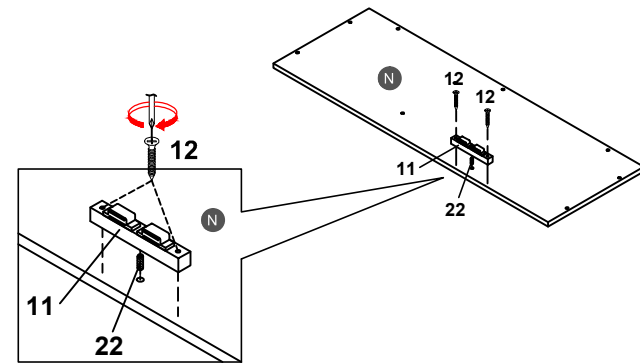

09:

11	12	22
		
x1	x2	x1



04:

16	3	7
		
x4	x4	x4

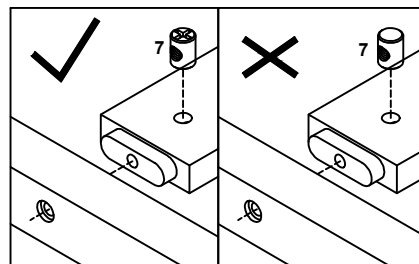
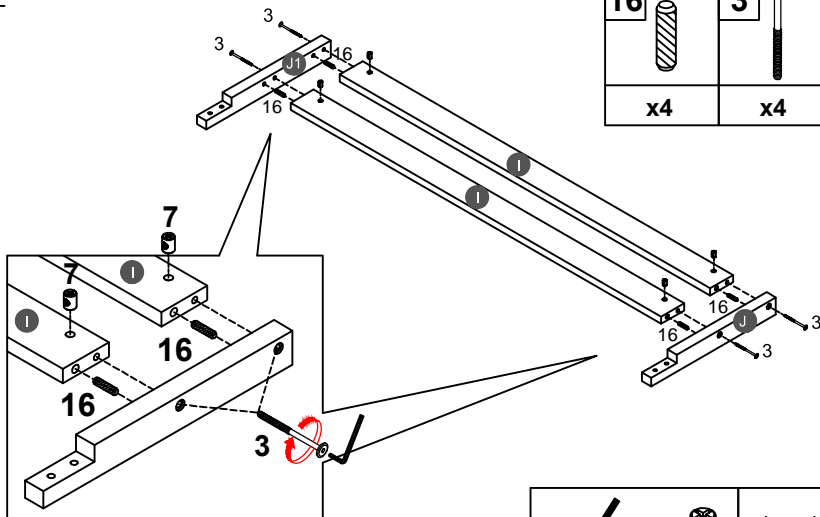

EN: Note: Part 7 will face up with the "x" mark on it, otherwise it cannot be tightened.

FR: Remarque: La pièce 7 sera face vers le haut avec la marque <<x>>, sinon elle ne peut pas être serrée.

08:



05:

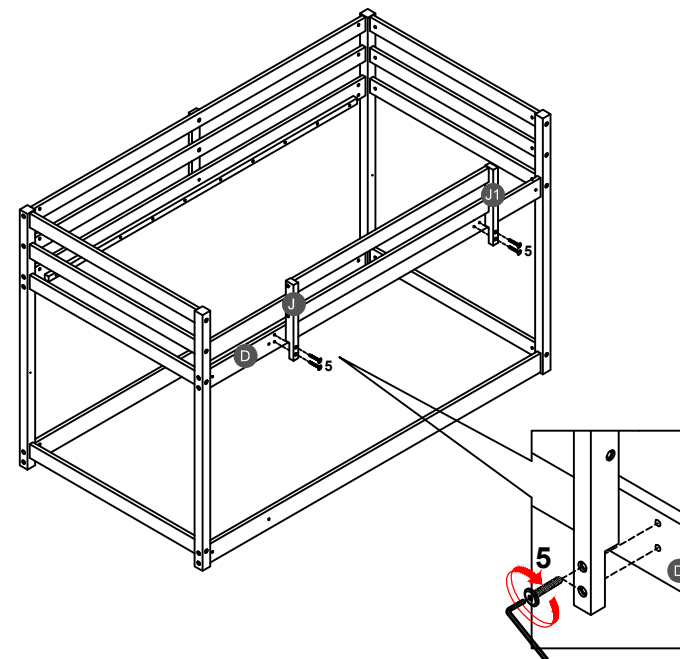
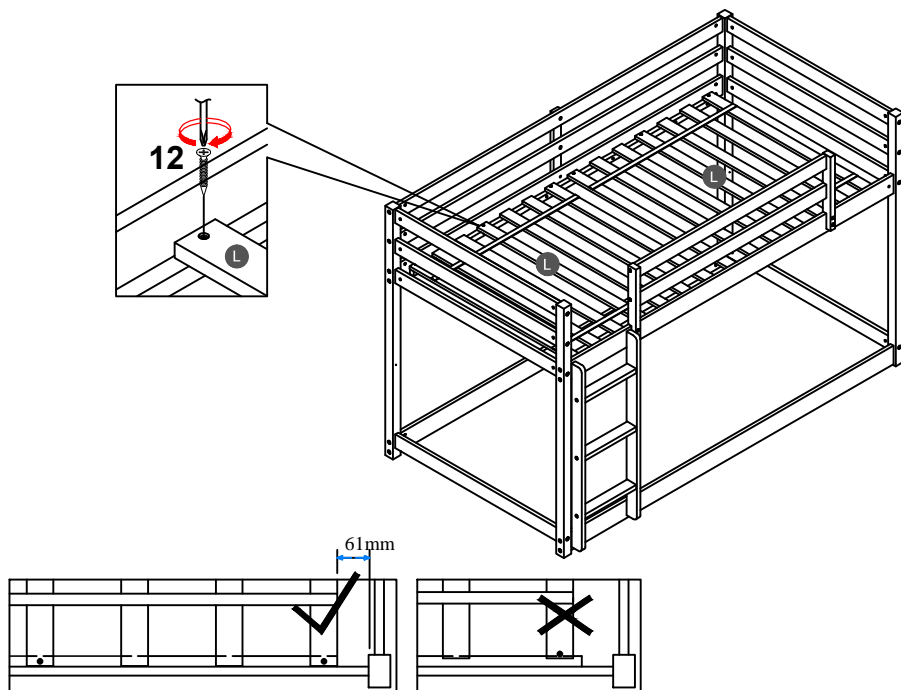
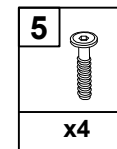



EN: Note: Do not lock the screws of the bed slats to the outermost edge of the bed slats, you need to leave a certain space at the edges, otherwise it will cause the board to break.

Do not lock the bed slats on the edge of the wood, please hold firmly before screwing, hold it in place with one hand, then lock the screw.

FR: Remarque: Ne verrouillez pas les vis des lattes de lit sur le bord le plus extérieur des lattes de lit, vous devez laisser un certain espace sur les bords, sinon cela causera la rupture de la planche.

Neverrouillez pas les lattes du lit sur le bord du bois, veuillez tenir fermement avant de visser, maintenez-le en place d'une main, puis verrouillez la vis.

06:

4	7
	
x6	x6

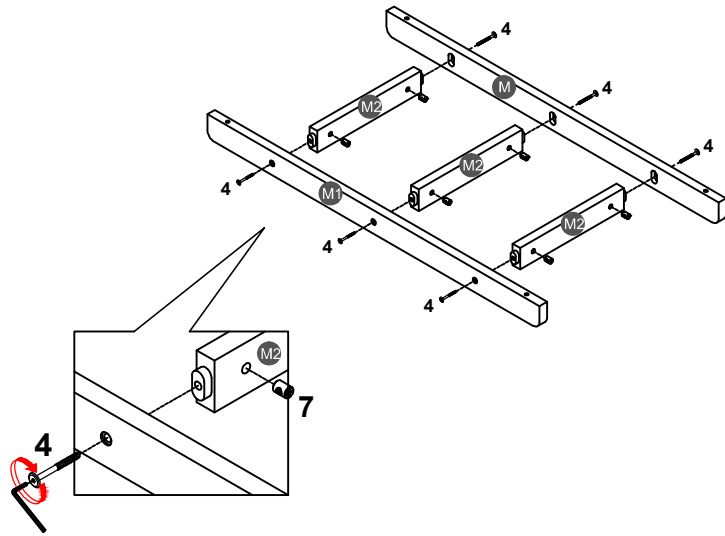

07:

14

x4

