

5 - Drawer Dresser
Commode à 5 Tiroirs

HV10328

EN



Before You Start



- ⚠ Please read all instructions carefully.
- ⚠ Retain instructions for future reference.
- ⚠ Separate and count all parts and hardware.
- ⚠ Read through each step carefully and follow the proper order.
- ⚠ We recommend that, where possible, all items are assembled near to the area in which they will be placed in use, to avoid moving the product unnecessarily once assembled.
- ⚠ Always place the product on a flat, steady and stable surface.
- ⚠ Keep all small parts and packaging materials for this product away from babies and children as they potentially pose a serious choking hazard.

FR





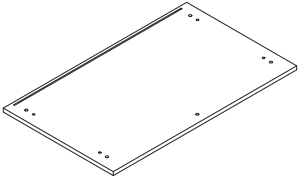

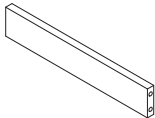
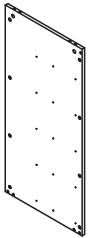
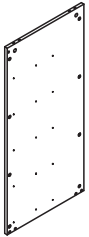
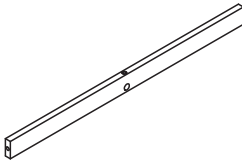
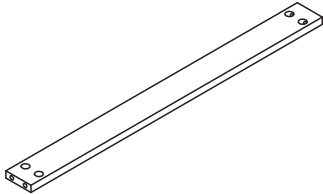

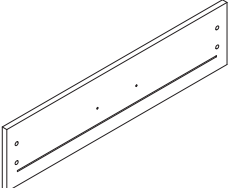
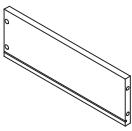
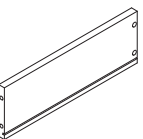
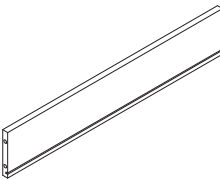
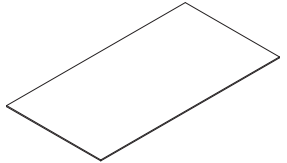
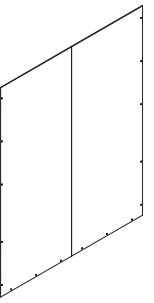

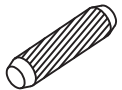
Avant de Commencer

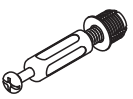
- ⚠ Veuillez lire attentivement toutes les instructions.
- ⚠ Conservez les instructions pour vous y référer ultérieurement.
- ⚠ Vérifiez toutes les pièces et les accessoires.
- ⚠ Lisez attentivement chaque étape et suivez l'ordre correct.
- ⚠ Nous recommandons que, dans la mesure du possible, tous les produits soient assemblés à proximité de la zone où ils seront utilisés, afin d'éviter tout déplacement inutile du produit une fois assemblé.
- ⚠ Placez toujours le produit sur une surface plane et stable.
- ⚠ Conservez toutes les petites pièces de ce produit et les matériaux d'emballage hors de portée des bébés et des enfants, car ils pourraient présenter un risque d'étouffement.

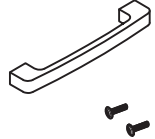
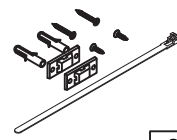

①  800*480*15mm x1	②  1027*60*25mm x2
③  1027*60*25mm x2	④  339*60*15mm x2
⑤  927*440*15mm x1	⑥  927*440*15mm x1
⑦  699*45*15mm x1	⑧  699*60*15mm x2

<p>⑨</p>  <p>726*177*15mm x5</p>	<p>⑩</p>  <p>350*118*15mm x5</p>
<p>⑪</p>  <p>350*118*15mm x5</p>	<p>⑫</p>  <p>643*118*15mm x5</p>
<p>⑬</p>  <p>653*345*5mm x5</p>	<p>⑭</p>  <p>932*730*3mm x1</p>

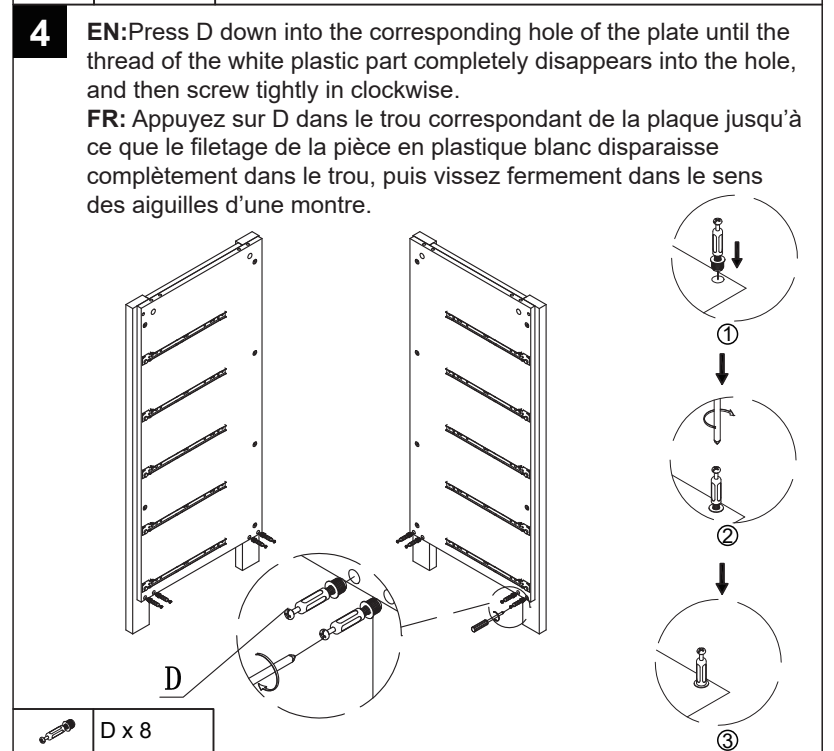
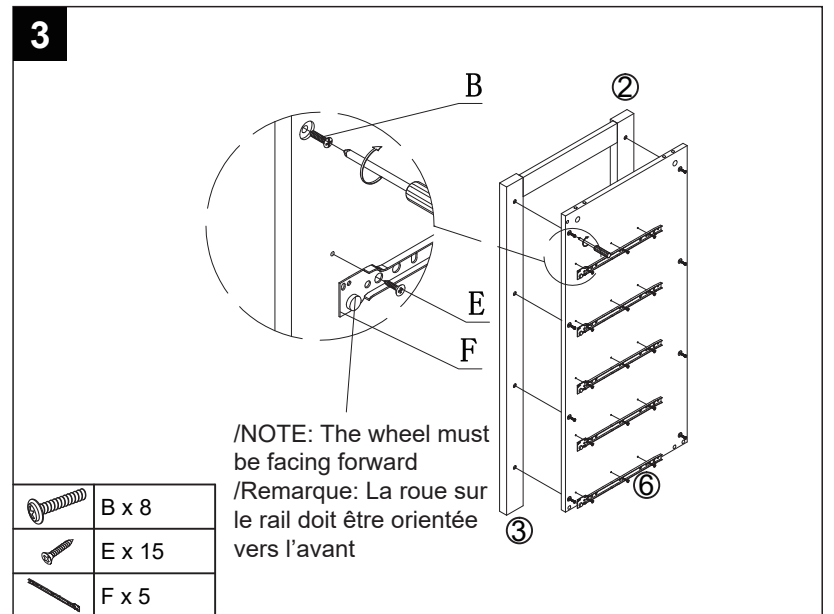
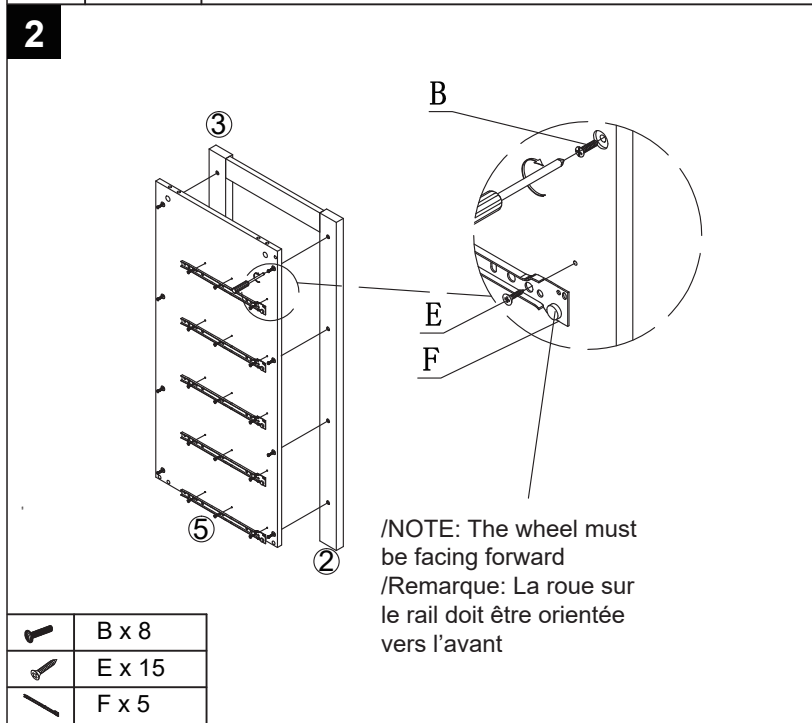
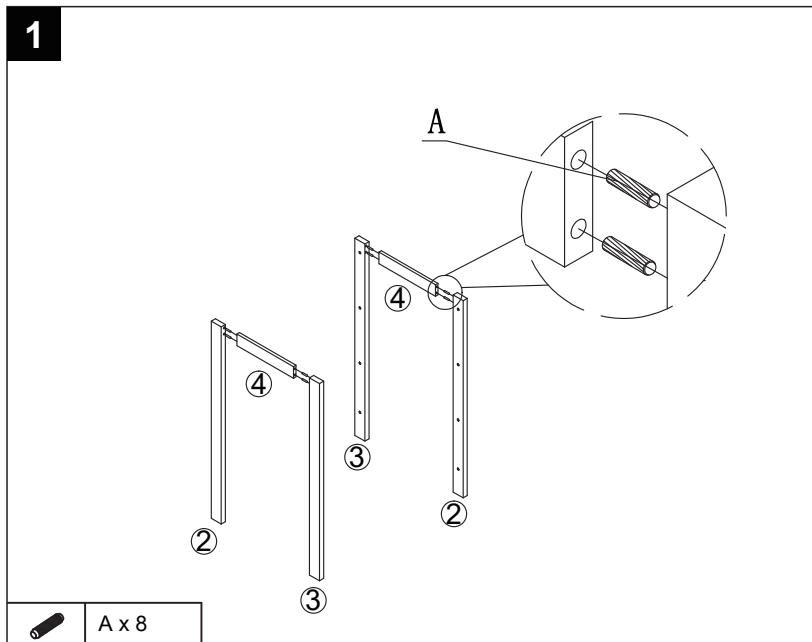
<p>A</p>  <p>φ8*30mm x14</p>	<p>B</p>  <p>M4*22mm x16</p>	<p>C</p>  <p>φ15*12mm x53</p>
<p>D</p>  <p>φ7*45mm x53</p>	<p>E</p>  <p>K3.5*14mm x78</p>	<p>F</p>  <p>L=300mm x5</p>
<p>G</p>  <p>L=135mm M4*18mm x5</p>	<p>H</p>  <p>x2</p> <p>I</p>  <p>x2</p>	<p>Spare Hardware/ Matériel de Remplacement</p>  <p>K3.5*14mm x3</p>  <p>φ15*12mm x2</p>  <p>φ7*45mm x2</p>

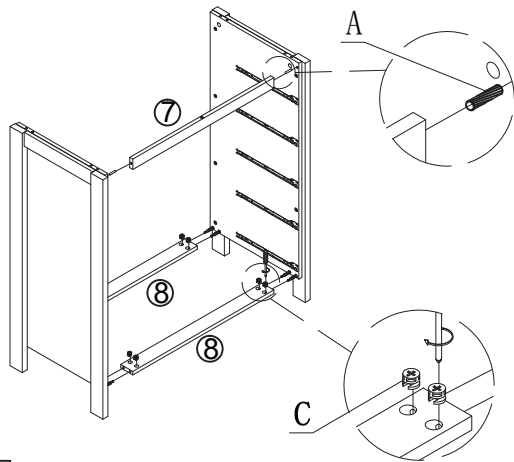

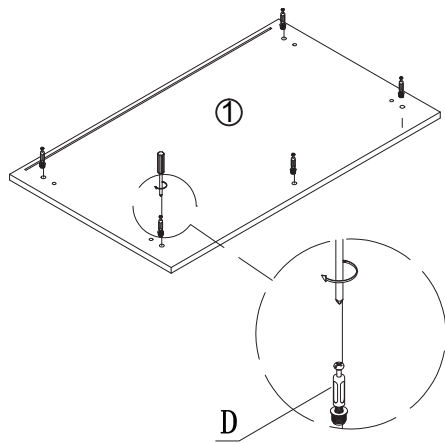

5

	A x 2
	C x 8

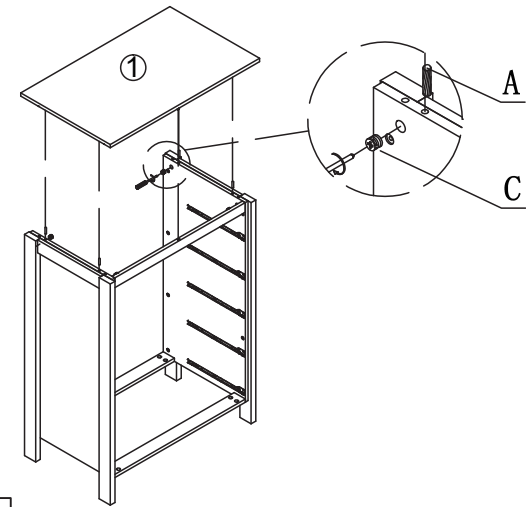

6

	D x 5
---	-------

7

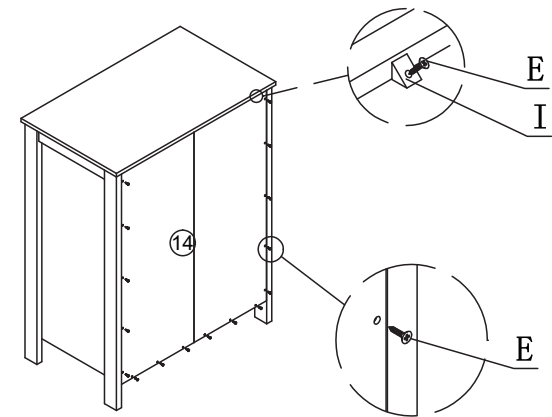
	A x 4
	C x 5

8

	E x 18
	I x 2

9

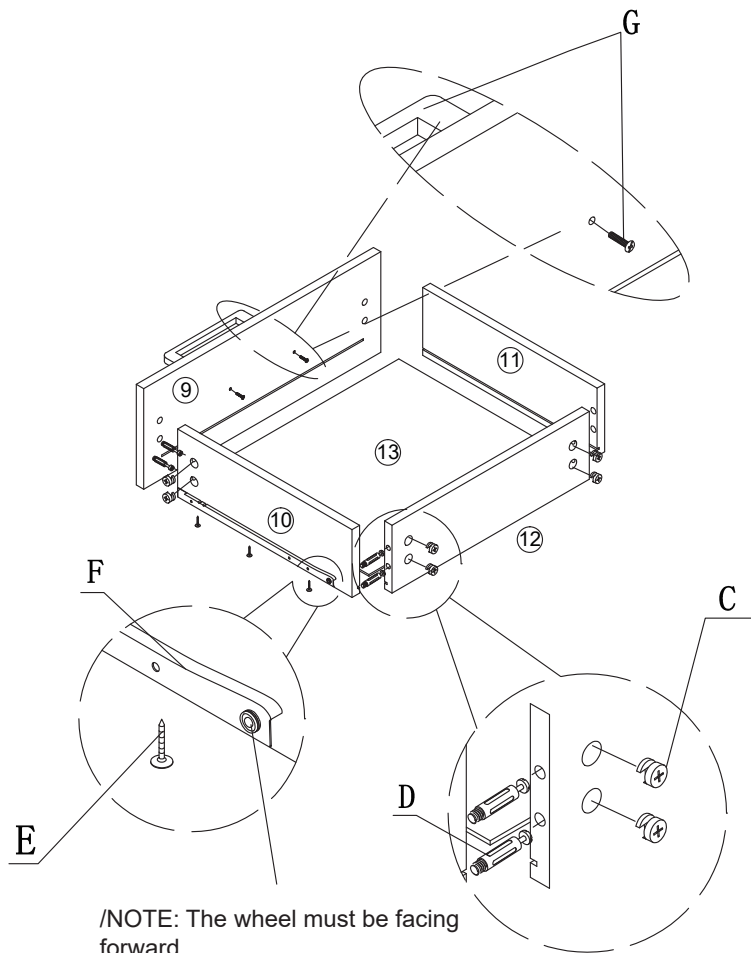

/NOTE: The wheel must be facing forward
/Remarque: La roue sur le rail doit être orientée vers l'avant

	C x 8
	D x 8
	Ex 6
	F x 1
	G x 1

X5

10

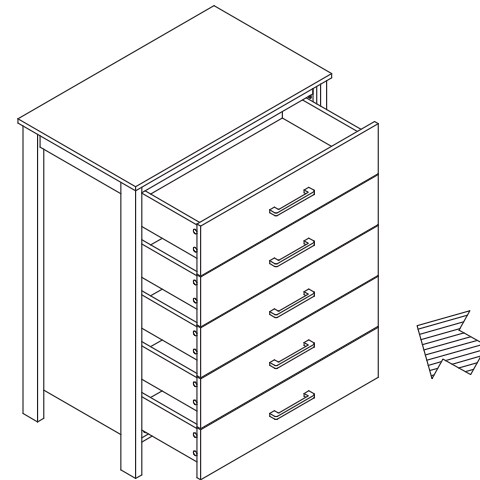

11

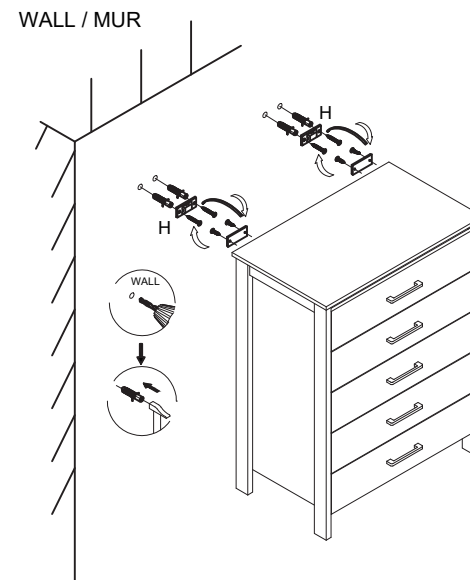

	H x 2
--	-------

EN

Installation Instructions

1. The nylon anti-tipping belt should be installed at the rear of the top of the cabinet.
2. The hole height on the wall shall be positioned and punched according to the height of the top plate of the cabinet, and the expansion rubber particles(8*35mm) shall be installed.
3. Install one anti-tipping device(44*20mm) onto the wall by two tapping screws($\phi 3.5 \times 40$ mm), and install the other anti-tipping device(44*20mm) to the back of the top plate by two tapping screws($\phi 3.5 \times 20$ mm).
4. Finally, connect the two anti-tipping devices with the anti-tipping belt and adjust the clearance.
5. Nylon anti-tipping belt must be installed.

FR

Instructions d'installation

1. La ceinture anti-basculement en nylon doit être installée à l'arrière du haut de l'armoire.
2. La hauteur du trou sur le mur doit être positionnée et perforée en fonction de la hauteur de la plaque supérieure de l'armoire, et les particules de caoutchouc d'expansion (8*35mm) doivent être installées.
3. Installez un dispositif anti-basculement(44*20mm) sur le mur par deux vis à taper($\phi 3,5 \times 40$ mm), et installez l'autre dispositif anti-basculement(44*20mm) à l'arrière de la plaque supérieure par deux vis à taper($\phi 3,5 \times 20$ mm).
4. Enfin, connectez les deux dispositifs anti-basculement avec la ceinture anti-basculement et ajustez le jeu.
5. La ceinture anti-basculement en nylon doit être installée.



WARNING / AVERTISSEMENT



EN

Children have died from furniture tipover. To reduce the risk of furniture tipover:

- ALWAYS install tipover restraint provided.
- NEVER put a TV on this product.
- NEVER allow children to stand, climb or hang on drawers, doors, or shelves.
- NEVER open more than one drawer at a time.
- Place heaviest items in the lowest drawers.

FR

Certains enfants sont morts suite au basculement de meubles. Pour réduire le risque de basculement des meubles :

- Installez TOUJOURS le dispositif de retenue fourni.
- Ne posez JAMAIS un téléviseur sur ce produit.
- Ne laissez JAMAIS les enfants se tenir, grimper ou s'accrocher aux tiroirs, portes ou étagères.
- N'ouvrez JAMAIS plus d'un tiroir à la fois.
- Placez les articles les plus lourds dans les tiroirs les plus bas.

EN



Return / Damage Claim Instructions

- ⚠ **DO NOT discard the box / original packaging.**
In case a return is required, the item must be returned in original box. Without this your return will not be accepted.
- ⚠ **Take a photo of the box markings.**
A photo of the markings (text) on the side of the box is required in case a part is needed for replacement. This helps our staff identify your product number to ensure you receive the correct parts.
- ⚠ **Take a photo of the damaged part (if applicable).**
A photo of the damage is always required to file a claim and get your replacement or refund processed quickly. Please make sure you have the box even if it is damaged.
- ⚠ **Send us an email with the images requested.**
Email us directly from marketplace where your item was purchased with the attached images and a description of your claim.

FR



Instructions De Retour / Réclamation De Dommages

- ⚠ **NE PAS jeter la boîte/l'emballage d'origine.**
Dans le cas où un retour est requis, l'article doit être retourné dans sa boîte d'origine. Sans cela, votre retour ne sera pas accepté.
- ⚠ **Prenez une photo des marquages de la boîte.**
Une photo des marquages (texte) sur le côté de la boîte est requise au cas où une pièce serait nécessaire pour le remplacement. Cela aide notre personnel à identifier votre numéro de produit pour s'assurer que vous recevez les bonnes pièces.
- ⚠ **Prenez une photo des dommages (le cas échéant).**
Une photo des dommages est toujours requise pour déposer une réclamation et obtenir rapidement votre remplacement ou votre remboursement. Assurez-vous d'avoir la boîte même si elle est endommagée.
- ⚠ **Envoyez-nous un e-mail avec les images demandées.**
Envoyez-nous un e-mail directement depuis le marché où votre article a été acheté avec les images ci-jointes et une description de votre réclamation.