









Bar Stools Set of 2
Lot de 2 Tabourets de Bar

JV10941

EN









Before You Start

-  Please read all instructions carefully.
-  Retain instructions for future reference.
-  Separate and count all parts and hardware.
-  Read through each step carefully and follow the proper order.
-  We recommend that, where possible, all items are assembled near to the area in which they will be placed in use, to avoid moving the product unnecessarily once assembled.
-  Always place the product on a flat, steady and stable surface.
-  Keep all small parts and packaging materials for this product away from babies and children as they potentially pose a serious choking hazard.

FR



Avant de Commencer

-  Veuillez lire attentivement toutes les instructions.
-  Conservez les instructions pour vous y référer ultérieurement.
-  Vérifiez toutes les pièces et les accessoires.
-  Lisez attentivement chaque étape et suivez l'ordre correct.
-  Nous recommandons que, dans la mesure du possible, tous les produits soient assemblés à proximité de la zone où ils seront utilisés, afin d'éviter tout déplacement inutile du produit une fois assemblé.
-  Placez toujours le produit sur une surface plane et stable.
-  Conservez toutes les petites pièces de ce produit et les matériaux d'emballage hors de portée des bébés et des enfants, car ils pourraient présenter un risque d'étouffement.

PART LIST / LISTE DES PIÈCES

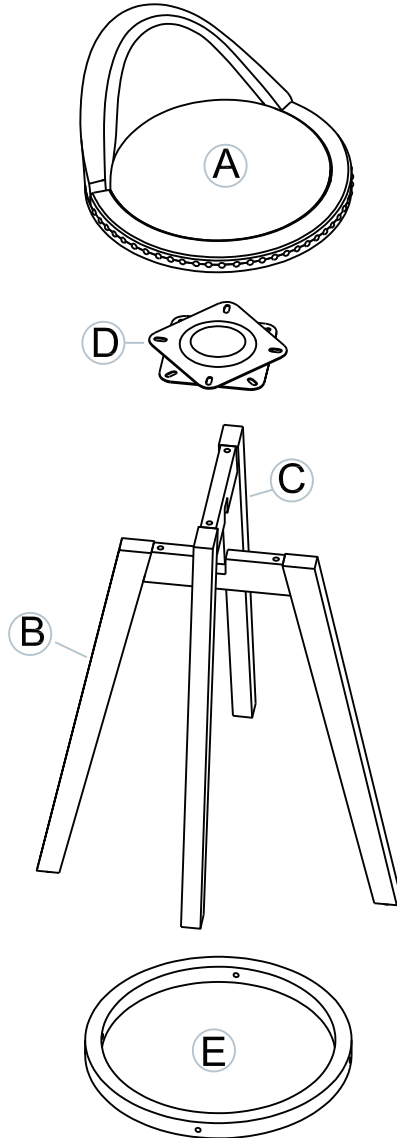

PART LIST / LISTE DES PIÈCES

A

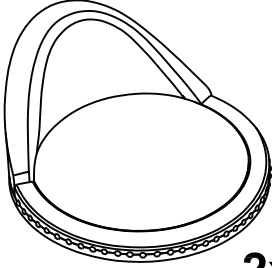

2x

B

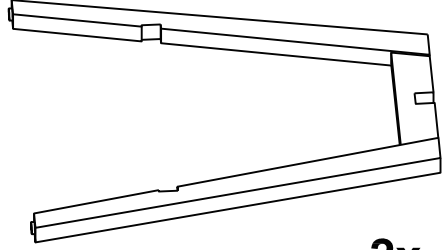

2x

C

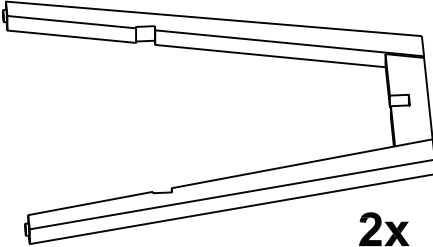

2x

D

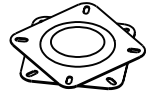

2x

E

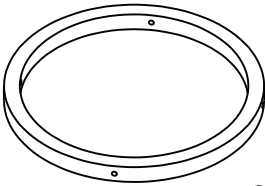

2x

HARDWARE LIST / LISTE DE MATÉRIEL

1 x24



FLAT WASHER
/ RONDELLE PLATE / ARANDELA PLANA
(1/4")

2 x24



SPRING WASHER
/ RONDELLE ÉLASTIQUE
(1/4")

3 x8



BOLT / BOULON
(Ø1/4" x 45mm)

4 x16



BOLT / BOULON
(Ø1/4" x 20mm)

5 x1



ALLEN KEY
/ CLÉ ALLEN

For 2 Stools / Pour 2 tabourets

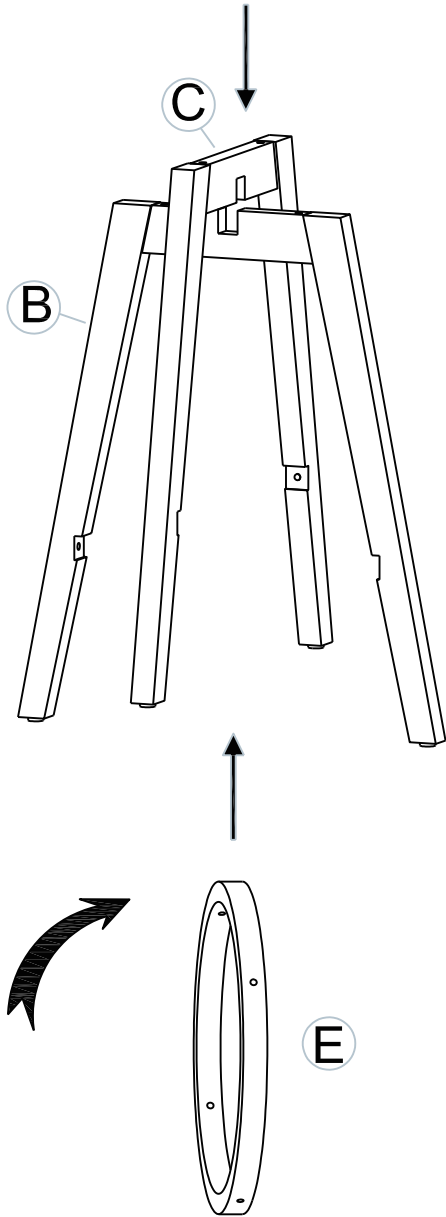

1

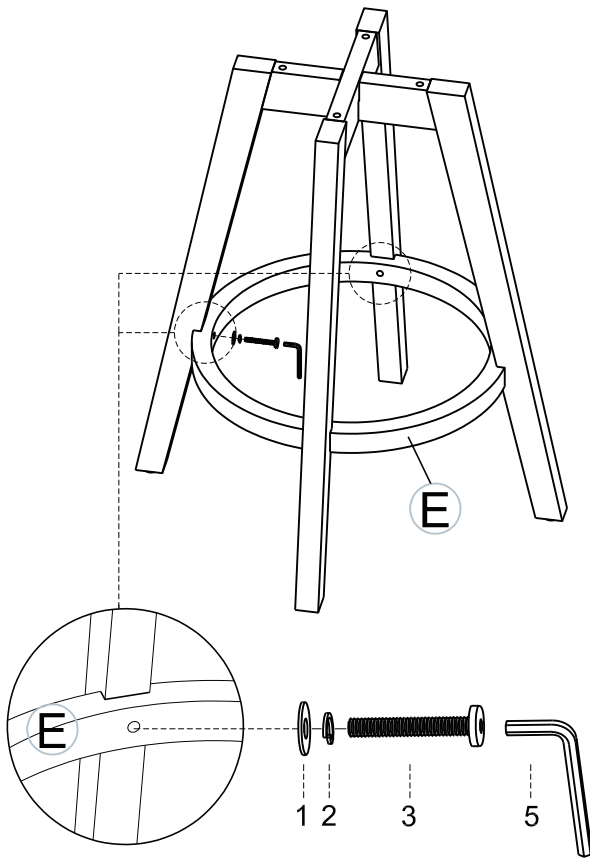

2





1		4
2		4

3		4
5		1

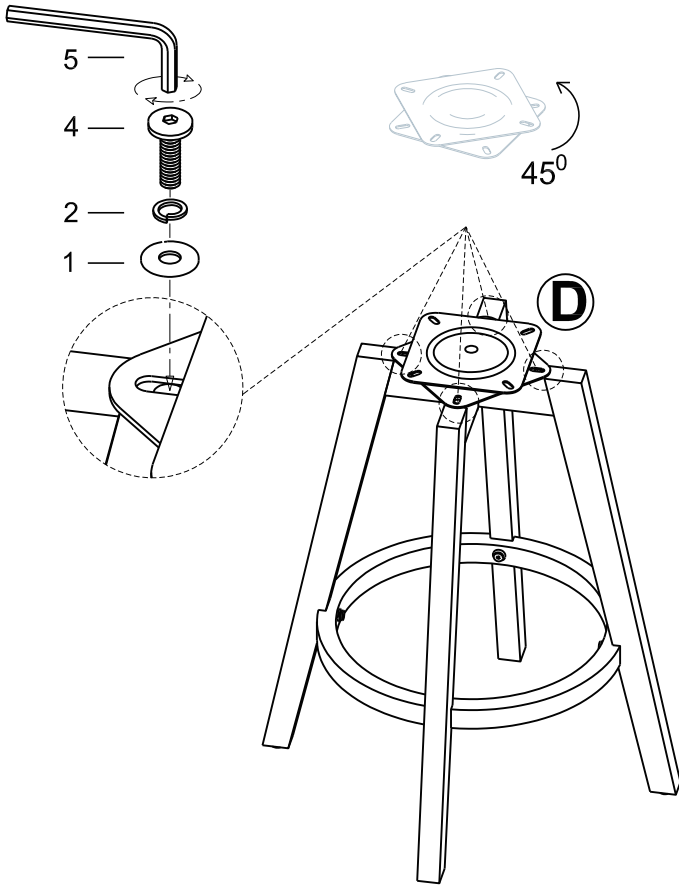
3





1		4
2		4

4		4
5		1

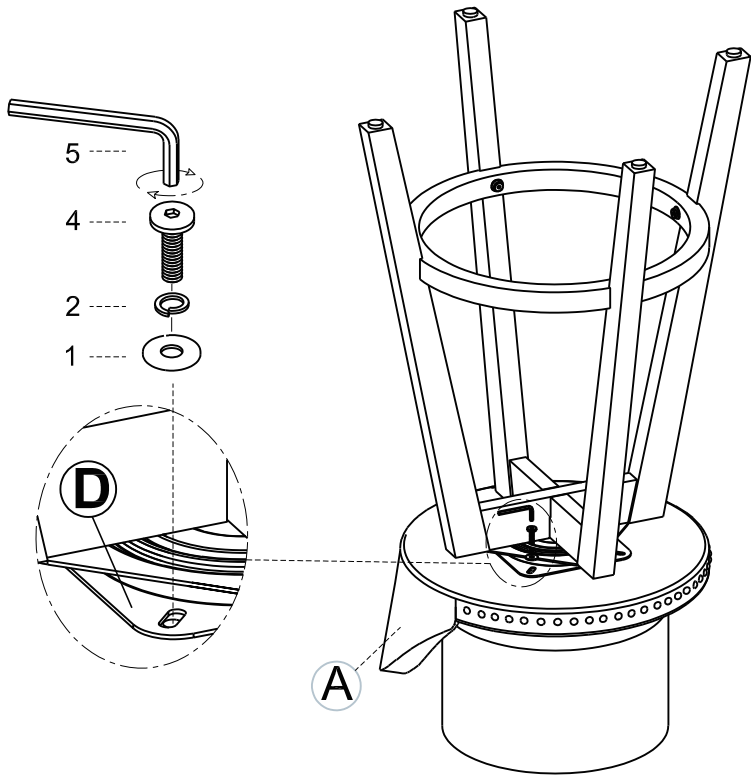
4



1		4
2		4

4		4
5		1

COMPLETE / COMPLÉTÉ

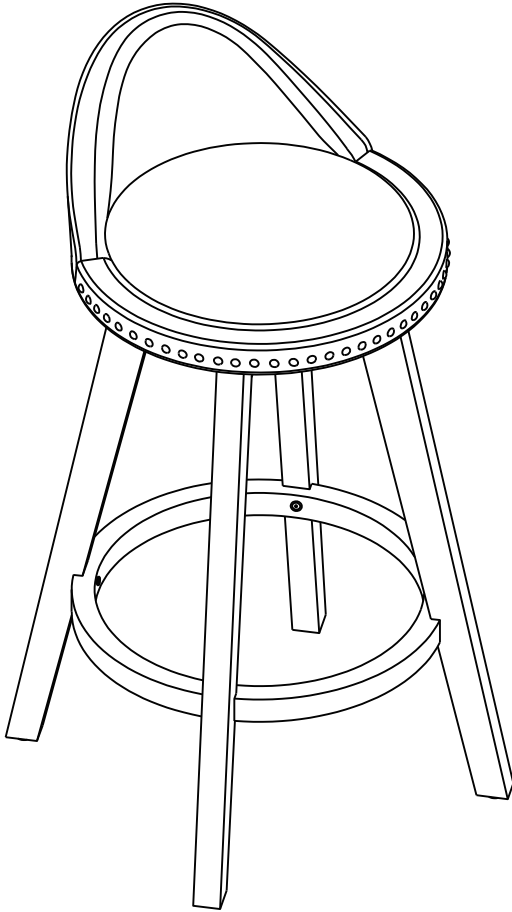





x2

EN







Return / Damage Claim Instructions

-  **DO NOT discard the box / original packaging.**
In case a return is required, the item must be returned in original box. Without this your return will not be accepted.
-  **Take a photo of the box markings.**
A photo of the markings (text) on the side of the box is required in case a part is needed for replacement. This helps our staff identify your product number to ensure you receive the correct parts.
-  **Take a photo of the damaged part (if applicable).**
A photo of the damage is always required to file a claim and get your replacement or refund processed quickly. Please make sure you have the box even if it is damaged.
-  **Send us an email with the images requested.**
Email us directly from marketplace where your item was purchased with the attached images and a description of your claim.

FR



Instructions De Retour / Réclamation De Dommages

-  **NE PAS jeter la boîte/l'emballage d'origine.**
Dans le cas où un retour est requis, l'article doit être retourné dans sa boîte d'origine. Sans cela, votre retour ne sera pas accepté.
-  **Prenez une photo des marquages de la boîte.**
Une photo des marquages (texte) sur le côté de la boîte est requise au cas où une pièce serait nécessaire pour le remplacement. Cela aide notre personnel à identifier votre numéro de produit pour s'assurer que vous recevez les bonnes pièces.
-  **Prenez une photo des dommages (le cas échéant).**
Une photo des dommages est toujours requise pour déposer une réclamation et obtenir rapidement votre remplacement ou votre remboursement. Assurez-vous d'avoir la boîte même si elle est endommagée.
-  **Envoyez-nous un e-mail avec les images demandées.**
Envoyez-nous un e-mail directement depuis le marché où votre article a été acheté avec les images ci-jointes et une description de votre réclamation.

USA office: Fontana **AUS** office: Truganina **GBR** office: Ipswich **FRA** office: Saint Vigor d'Ymonville

If you're having difficulty, our friendly customer team is always here to help.



USA:cs.us@costway.com
AUS:cs.au@costway.com
GBR:cs.uk@costway.com
FRA:cs.fr@costway.com