

Bar Stool Set of 2
Lot de 2 Tabourets de Bar

JV10945

EN



Before You Start

- ⚠ Please read all instructions carefully.
- ⚠ Retain instructions for future reference.
- ⚠ Separate and count all parts and hardware.
- ⚠ Read through each step carefully and follow the proper order.
- ⚠ We recommend that, where possible, all items are assembled near to the area in which they will be placed in use, to avoid moving the product unnecessarily once assembled.
- ⚠ Always place the product on a flat, steady and stable surface.
- ⚠ Keep all small parts and packaging materials for this product away from babies and children as they potentially pose a serious choking hazard.





FR





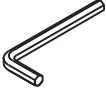

Avant de Commencer

- ⚠ Veuillez lire attentivement toutes les instructions.
- ⚠ Conservez les instructions pour vous y référer ultérieurement.
- ⚠ Vérifiez toutes les pièces et les accessoires.
- ⚠ Lisez attentivement chaque étape et suivez l'ordre correct.
- ⚠ Nous recommandons que, dans la mesure du possible, tous les produits soient assemblés à proximité de la zone où ils seront utilisés, afin d'éviter tout déplacement inutile du produit une fois assemblé.
- ⚠ Placez toujours le produit sur une surface plane et stable.
- ⚠ Conservez toutes les petites pièces de ce produit et les matériaux d'emballage hors de portée des bébés et des enfants, car ils pourraient présenter un risque d'étouffement.

Part List / Liste des Pièces

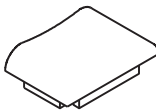
<p>A</p>  <p>Ø1/4"x50mm</p> <p>Bolt / Boulon x 16</p>	<p>B</p>  <p>Ø1/4"</p> <p>Lock Washer / Rondelle de Blocage x 16</p>	<p>C</p>  <p>Ø1/4"</p> <p>Flat Washer Rondelle Plate x 16</p>
<p>D</p>  <p>4mm</p> <p>Allen Wrench / Clé Allen x 1</p>	<p>E</p>  <p># 4x40mm</p> <p>Screw / Vis x 16</p>	

Hardware List / Liste des Accessoires

<p>1</p>  <p>Seat / Siège x2</p>	<p>2</p>  <p>Leg L/R / Pied L/R x8</p>
<p>3</p>  <p>Stretchers / Tendeur x 4</p>	<p>4</p>  <p>Stretchers / Tendeur x 4</p>

01

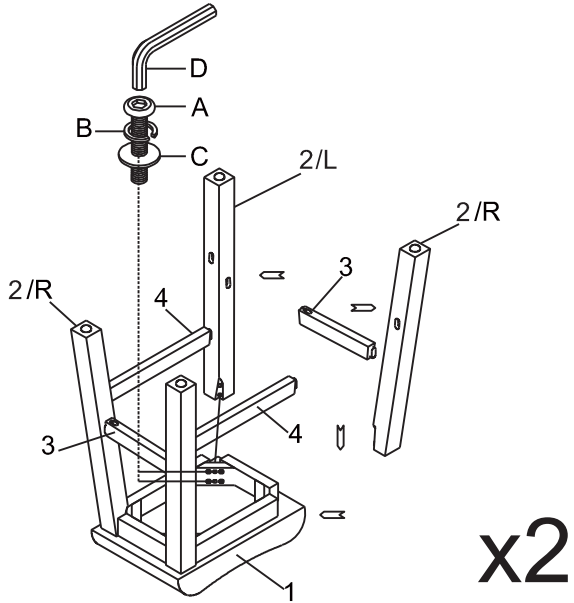

02

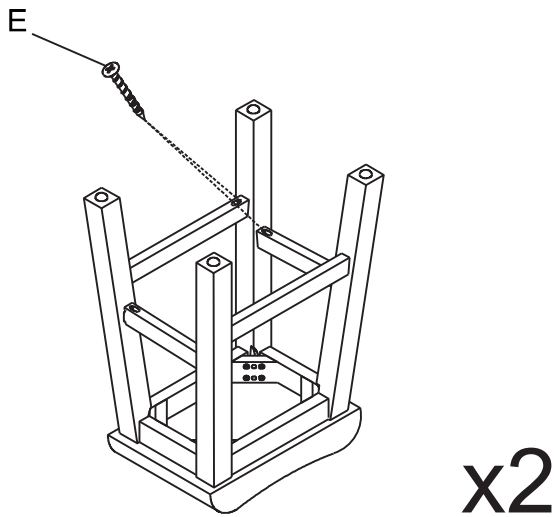

03

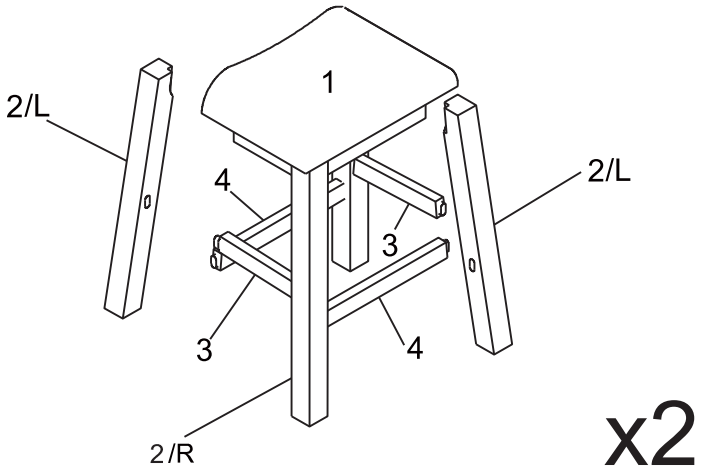



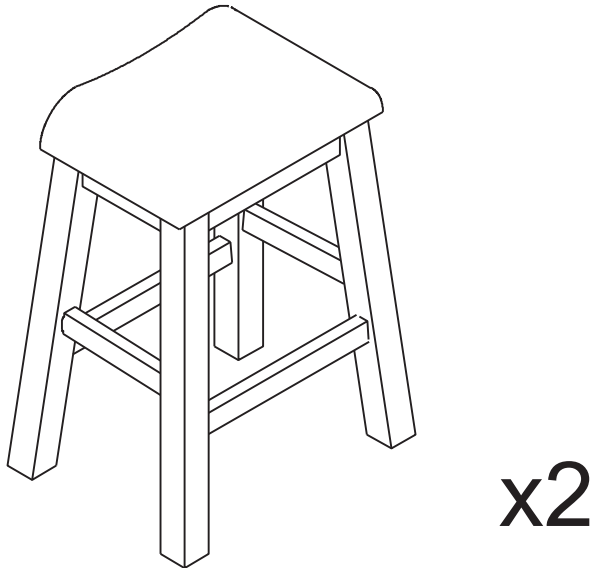

04



EN







Return / Damage Claim Instructions

-  **DO NOT discard the box / original packaging.**
In case a return is required, the item must be returned in original box. Without this your return will not be accepted.
-  **Take a photo of the box markings.**
A photo of the markings (text) on the side of the box is required in case a part is needed for replacement. This helps our staff identify your product number to ensure you receive the correct parts.
-  **Take a photo of the damaged part (if applicable).**
A photo of the damage is always required to file a claim and get your replacement or refund processed quickly. Please make sure you have the box even if it is damaged.
-  **Send us an email with the images requested.**
Email us directly from marketplace where your item was purchased with the attached images and a description of your claim.

FR



Instructions De Retour / Réclamation De Dommages

-  **NE PAS jeter la boîte/l'emballage d'origine.**
Dans le cas où un retour est requis, l'article doit être retourné dans sa boîte d'origine. Sans cela, votre retour ne sera pas accepté.
-  **Prenez une photo des marquages de la boîte.**
Une photo des marquages (texte) sur le côté de la boîte est requise au cas où une pièce serait nécessaire pour le remplacement. Cela aide notre personnel à identifier votre numéro de produit pour s'assurer que vous recevez les bonnes pièces.
-  **Prenez une photo des dommages (le cas échéant).**
Une photo des dommages est toujours requise pour déposer une réclamation et obtenir rapidement votre remplacement ou votre remboursement. Assurez-vous d'avoir la boîte même si elle est endommagée.
-  **Envoyez-nous un e-mail avec les images demandées.**
Envoyez-nous un e-mail directement depuis le marché où votre article a été acheté avec les images ci-jointes et une description de votre réclamation.

USA office: Fontana **AUS** office: Truganina **GBR** office: Ipswich **FRA** office: Saint Vigor d'Ymonville

If you're having difficulty, our friendly customer team is always here to help.



USA: cs.us@costway.com
AUS: cs.au@costway.com
GBR: cs.uk@costway.com
FRA: cs.fr@costway.com