

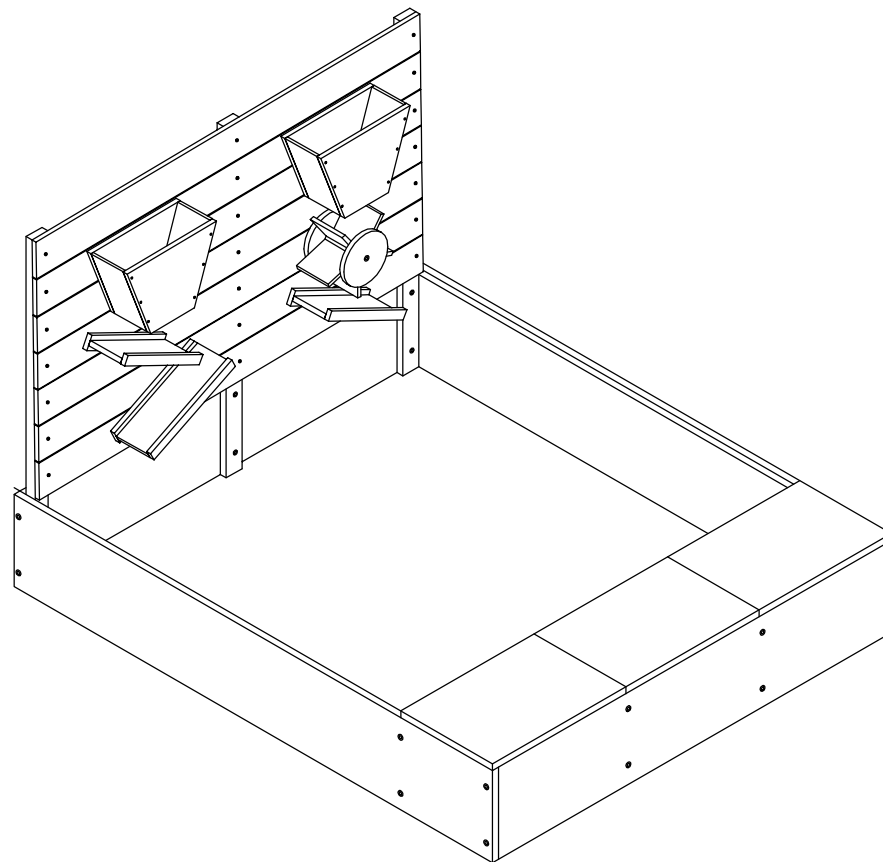

Please give us a chance to make it right and do better !

Contact our friendly customer service department for help first.
 Replacements for missing or damaged parts will be shipped ASAP !

US office: Fontana UK office: Ipswich AU office: Truganina



Contact Us !

Do NOT return this item.

Contact our friendly customer service department for help first.



US: cs.us@costway.com
 UK: cs.uk@costway.com
 AU: cs.au@costway.com

USER'S MANUAL

Kids Sand Box TS10040

THIS INSTRUCTION BOOKLET CONTAINS **IMPORTANT** SAFETY INFORMATION. PLEASE READ AND KEEP FOR FUTURE REFERENCE.



Before You Start

Please read all instructions carefully and keep it for future reference.

General Security Warning

Caution: The Product is not suitable for the children under 3 years

Danger: Keep all small parts and packaging materials for this product away from babies and children, otherwise they may pose a choking hazard.

Danger: Lack of attachment may cause a risk of tipping.



WARNING:
CHOKING HAZARD-Small parts.
Not for children under 3 years.

Warning for Assembly

- ⚠ Assembled only by adults
- ⚠ Remove all Packaging, separate and count all parts and hardware.
- ⚠ Read through each step carefully and follow the proper order.
- ⚠ We recommend that, where possible, all items are assembled near the area in which they will be placed in use, to avoid moving the product unnecessarily once assembled.
- ⚠ Ensure a secure surface during installation, and place the product always on a flat, steady and stable surface.

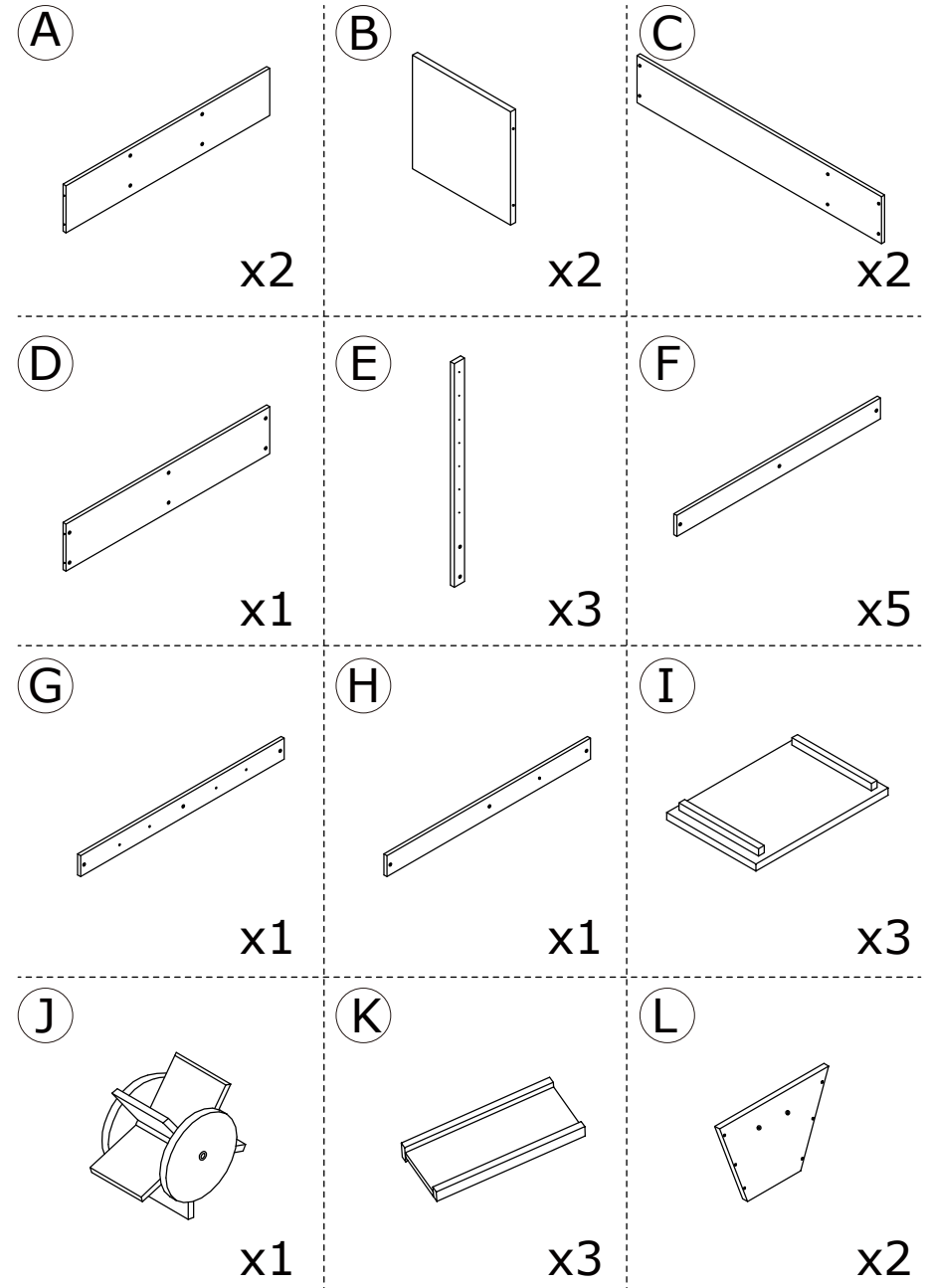

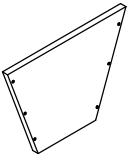
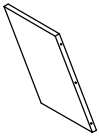
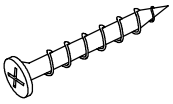
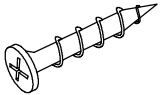
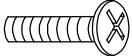
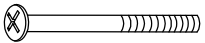
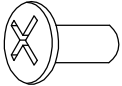
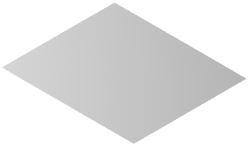
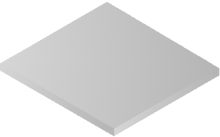
<p>(M)</p>  <p>x2</p>	<p>(N)</p>  <p>x4</p>	<p>(O)</p>  <p>4x35mm</p> <p>x20</p>
<p>(P)</p>  <p>4x25mm</p> <p>x51</p>	<p>(Q)</p>  <p>6x25mm</p> <p>x10</p>	<p>(R)</p>  <p>6x90mm</p> <p>x1</p>
<p>(S)</p>  <p>8x12mm</p> <p>x6</p>	<p>(T)</p>  <p>Cushion cloth</p> <p>x1</p>	<p>(U)</p>  <p>Covering cloth</p> <p>x1</p>

ASSEMBLY INSTRUCTIONS

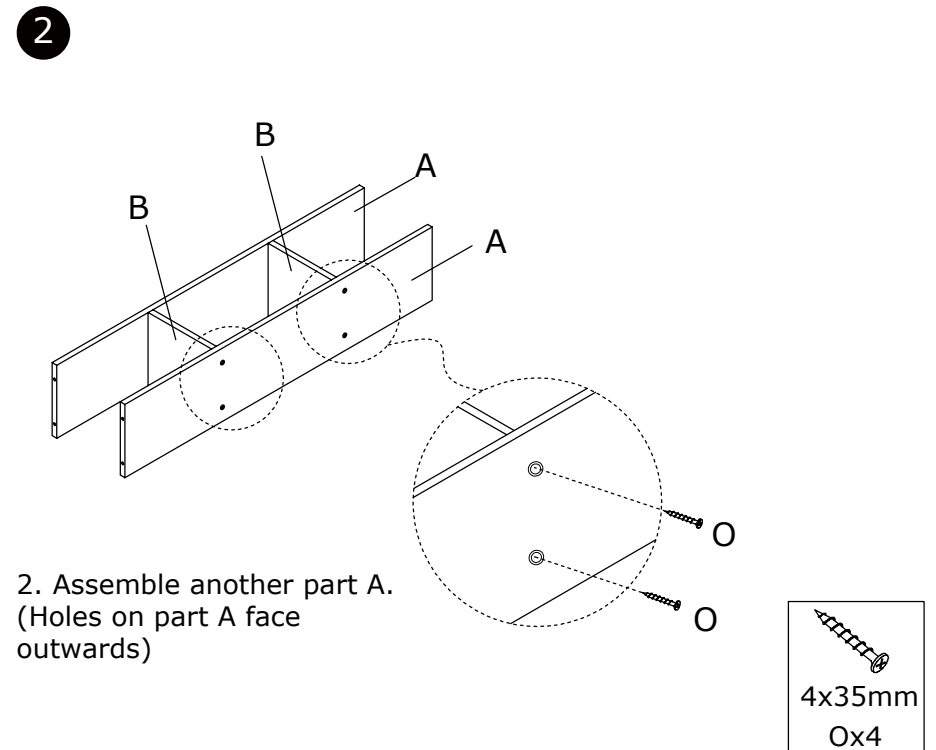
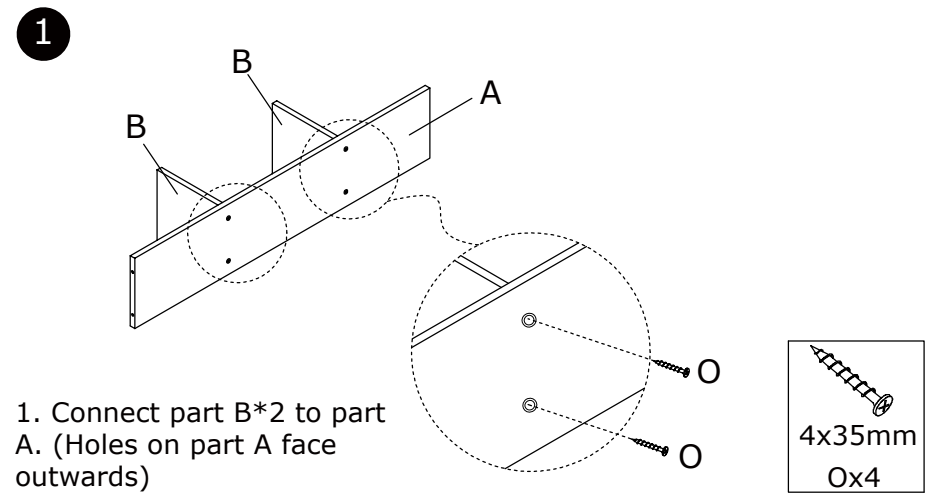

3

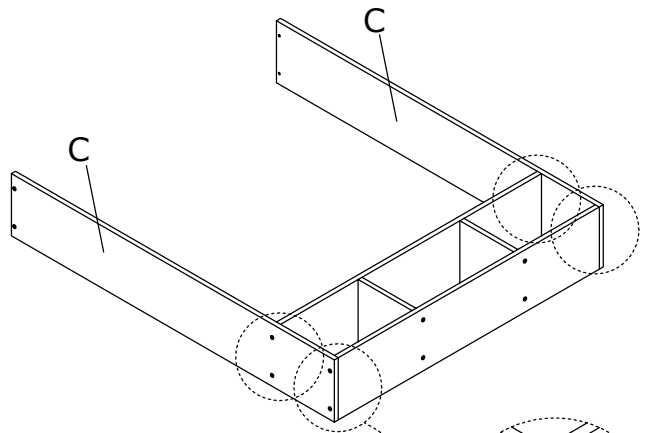

3. Attach part C*2. (Holes on part C face outwards)

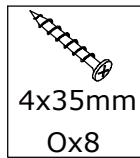
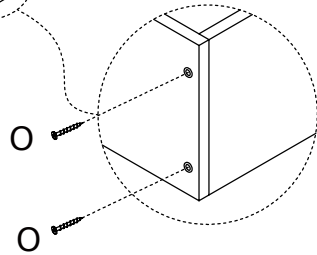

5

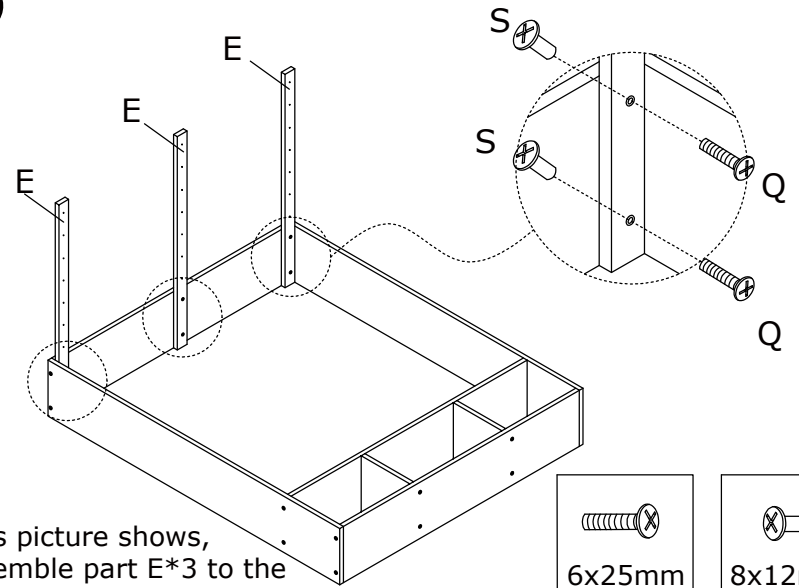

5. As picture shows, assemble part E*3 to the inner side of part D. (Holes on part E face inwards)

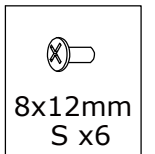
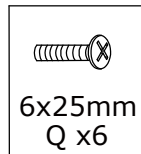

4

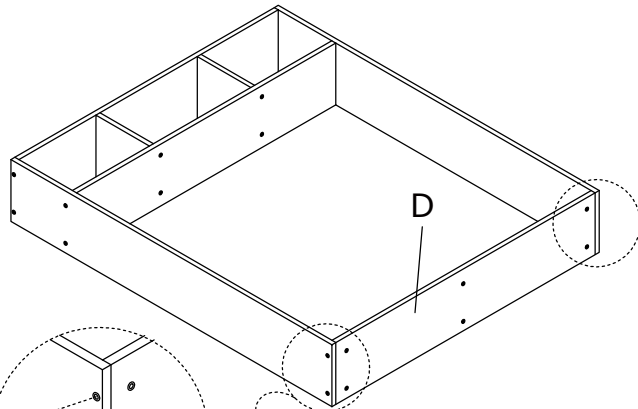

4. Attach part D. (Holes on part D face outwards)

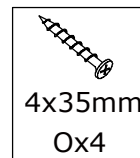
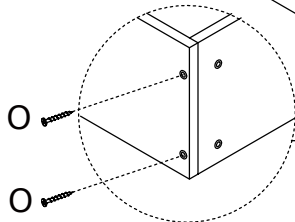

6

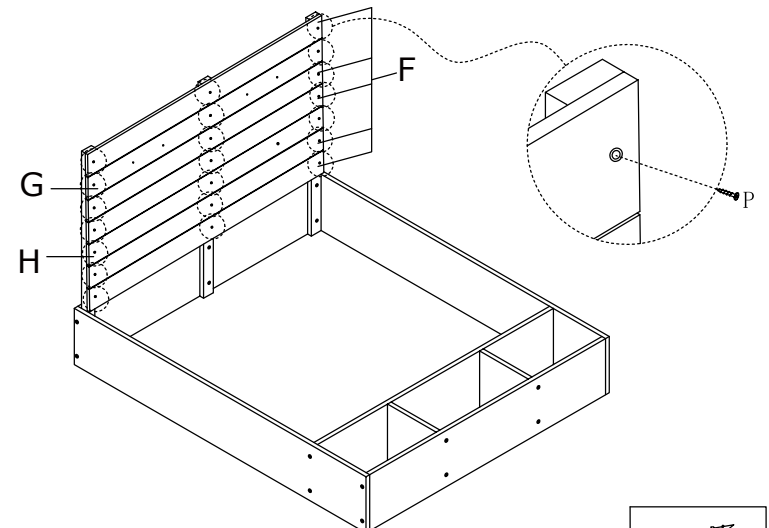

6. Assemble part F, G and H on the part E. Assemble them from the top to the bottom in the sequence of F G F F H F F, seven boards in total. (Holes on 7 boards all face inwards)

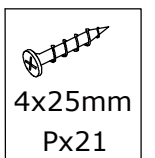

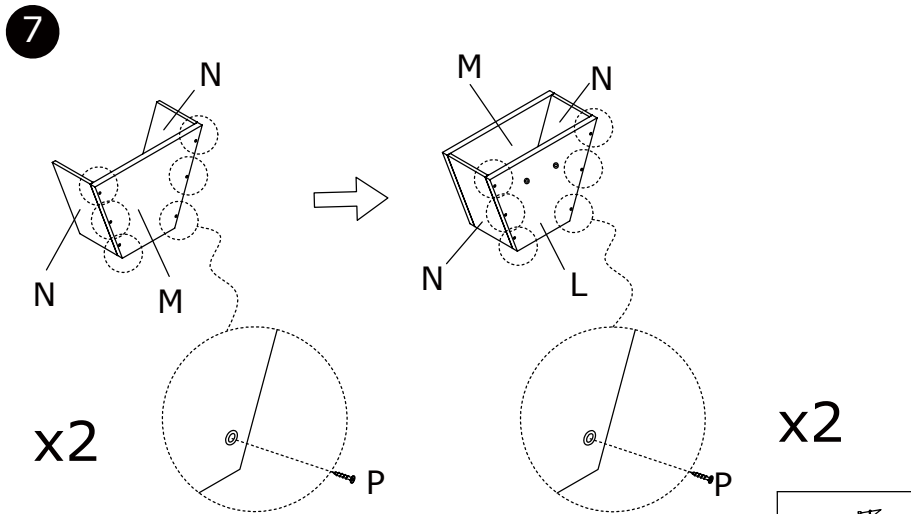

7. Assemble two funnel fittings. Assemble part N, M and L.
 Note: Holes on part M and L face outward.
 Align the top and bottom ends of four boards of the funnel. If it isn't aligned, loosen the screws and align them, then tighten the screws again.

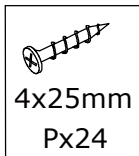

08

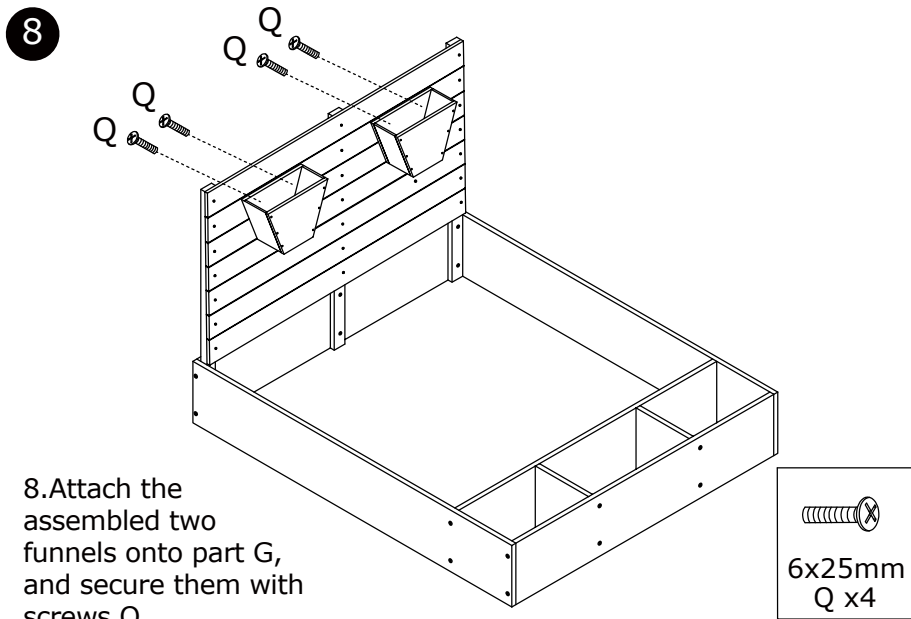

8. Attach the assembled two funnels onto part G, and secure them with screws Q.

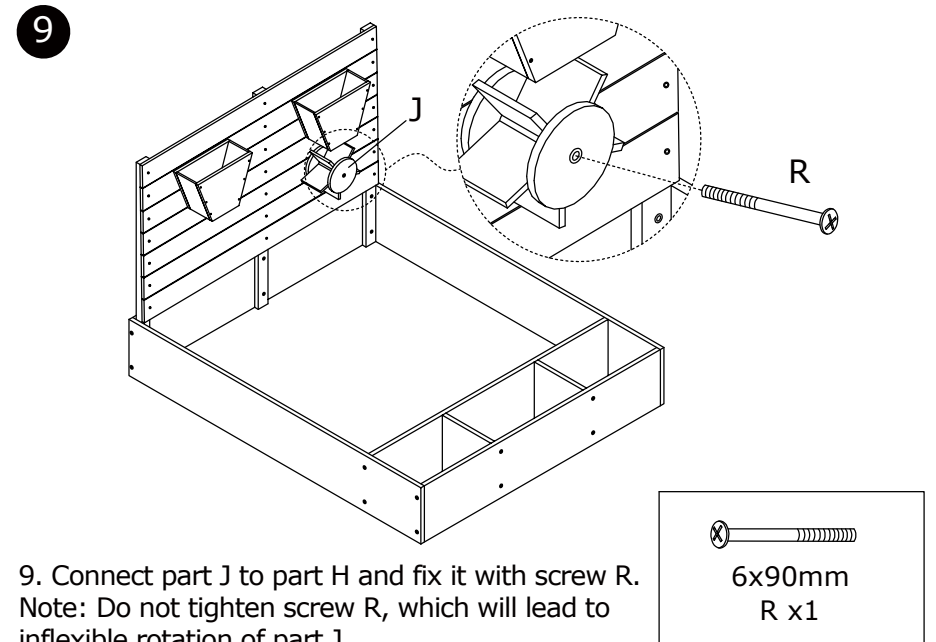
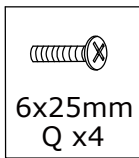

9. Connect part J to part H and fix it with screw R.
 Note: Do not tighten screw R, which will lead to inflexible rotation of part J.

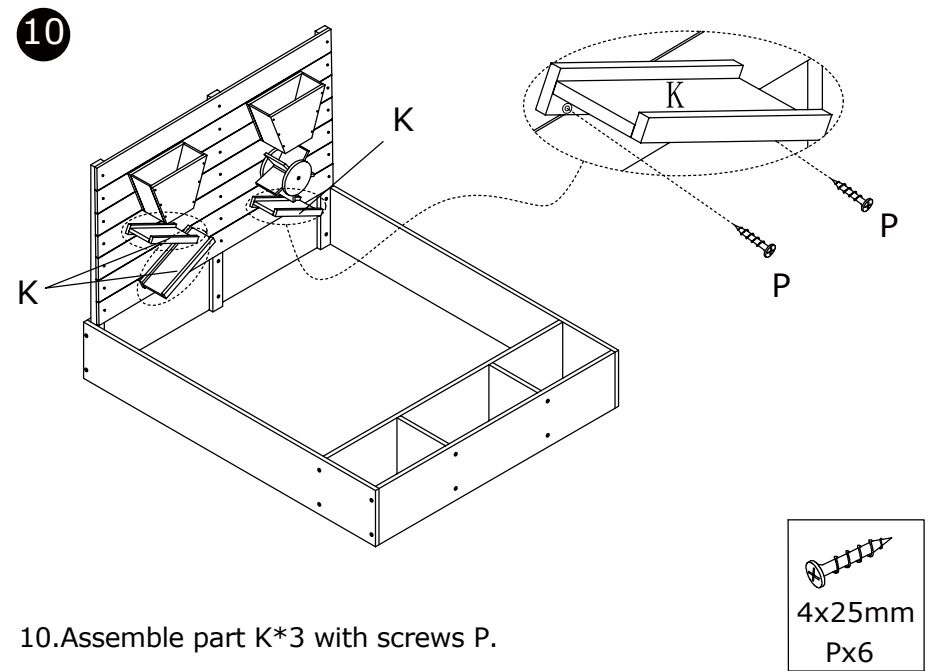
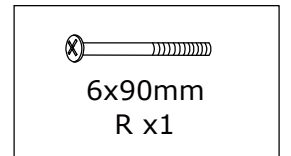

10. Assemble part K*3 with screws P.

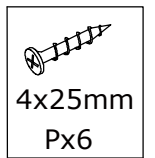

09

11

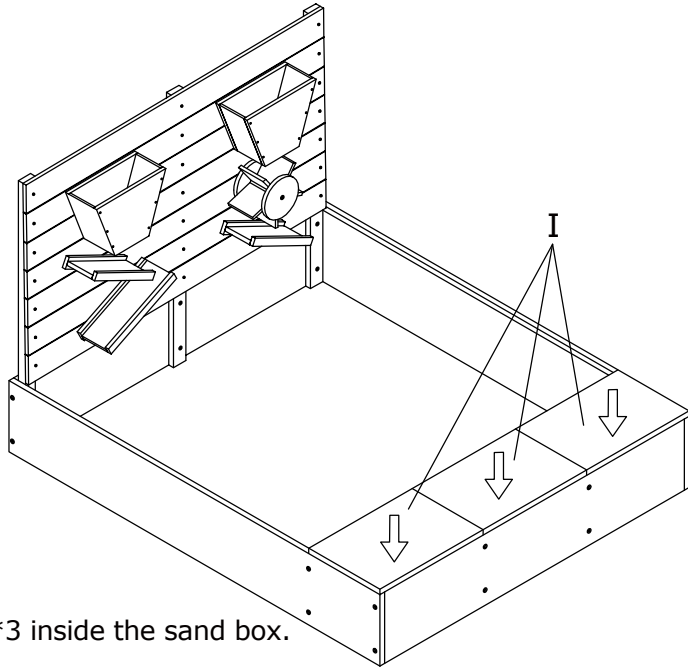

11. Place part I*3 inside the sand box.

12

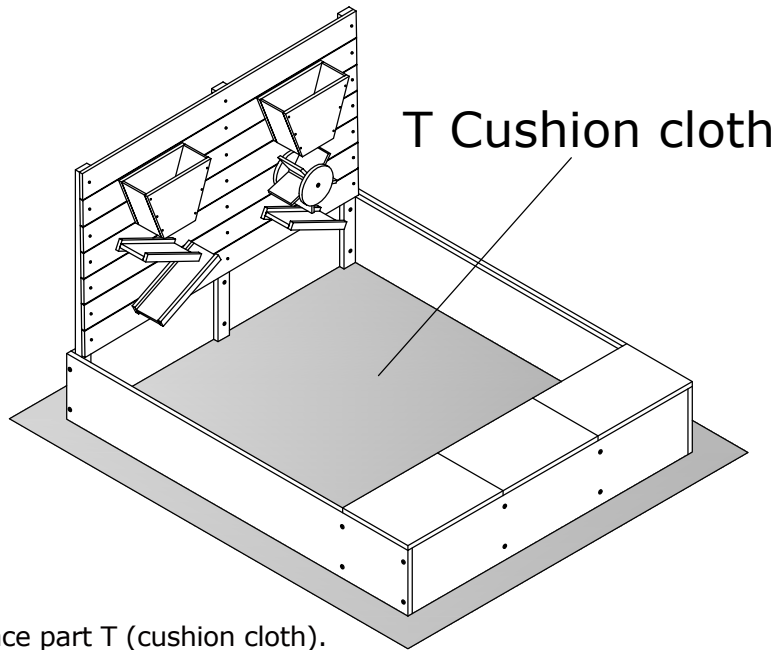

12. Place part T (cushion cloth).

13

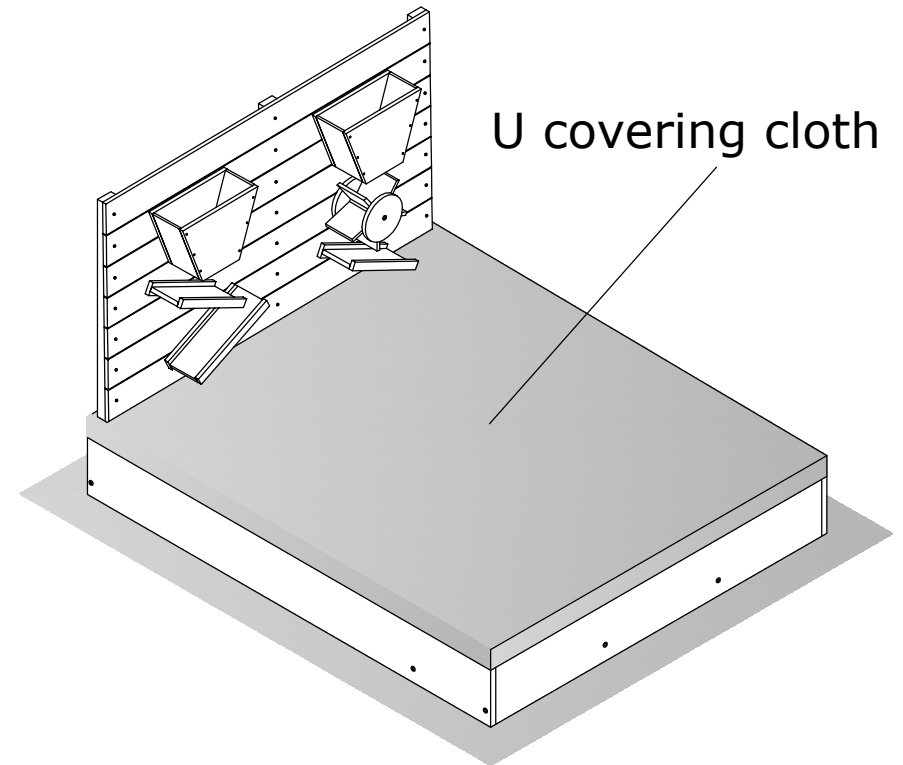

13. When not in use, cover the sand box with part U (covering cloth).