



DMT Control Dual Mode Tone Control With Frequency Selector Switches

The DMT Tone Control is a passive dual mode tone filter that can operate in either HIGH PASS or LOW PASS modes. This greatly expands the utility of the instruments controls vs. a traditional tone control. A frequency selector switch for each mode further adds to the DMT Controls versatility.

LOW PASS MODE - Push/Pull pot DOWN In this mode, the DMT control removes different ranges of high frequencies and lets the low frequencies pass thru the tone filter to the output.

Low Pass Frequency Switch ON DMT Control will remove treble frequencies and some midrange frequencies.

Low Pass Frequency Switch OFF DMT Control will remove treble frequencies only.

HIGH PASS MODE - Push/Pull pot UP In this mode, the DMT Control removes different a ranges of low frequencies and lets high frequencies pass thru the tone filter to the output.

High Pass Frequency Switch ON DMT Control will remove bass frequencies only.

HIGH Pass Frequency Switch OFF DMT Control will remove bass frequencies and some midrange frequencies.

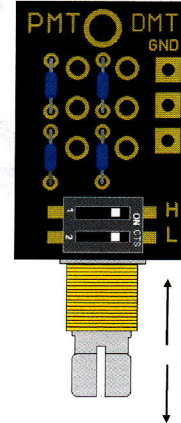

- ← Ground-To back of volume pot
- ← Input from Pickups or Controls
- ← Output to Controls or Jack
- ← High Pass Frequency Selector Switch
- ← Low Pass Frequency Selector Switch

↑ Push/Pull Pot DOWN for LOW PASS Mode (treble cut)
 ↓ Push/Pull Pot UP for HIGH PASS Mode (bass cut)

Typical Wiring

2 Volume & 2 DMT Controls

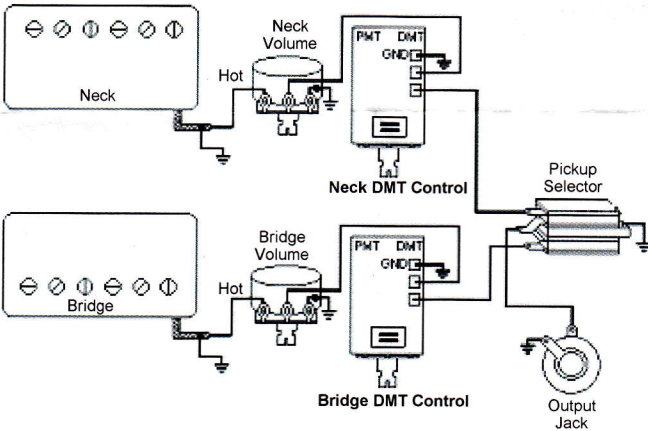

2 Volume & 1 DMT Control

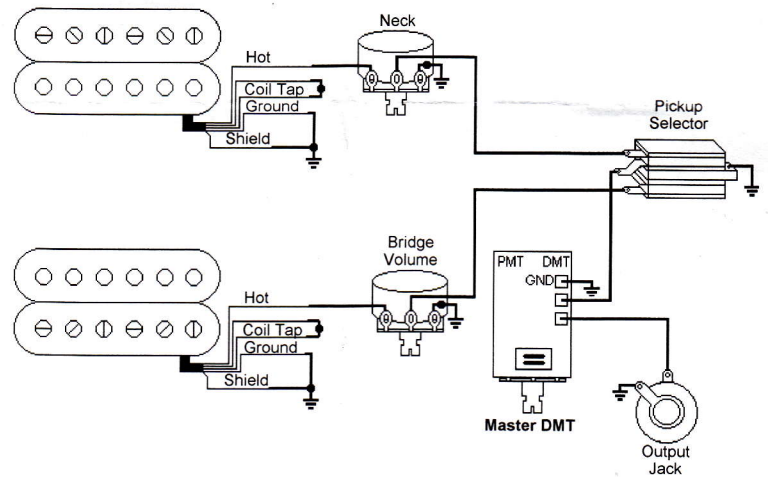

1 Volume & 2 DMT Controls

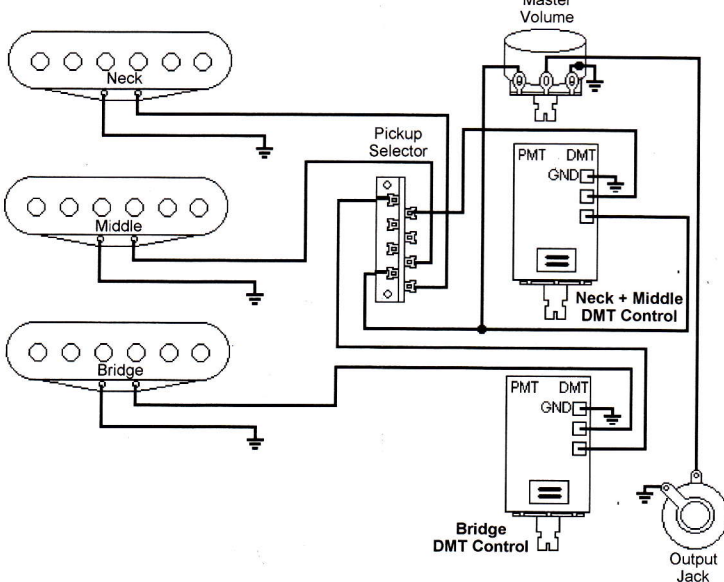

1 Volume & 1 DMT Control

