



HCP Control

Humbucker Control Pot With Coil Filter Modes

The HCP Humbucker Control Pot is a passive dual mode coil selector that eliminates the additional switches associated with coil splitting a pair of humbuckers which greatly simplifies operation. In TAP mode, tonal control is expanded with the ability to tap the selected coil of each humbucker (either North or South) in varying amounts as the HCP control is turned acting as a "fader" from humbucker to single coil simultaneously for both pickups (or a single pickup if only one humbucker is connected). In FILTER mode, turning the HCP control applies varying amounts of a high frequency filter to the selected coils (either North or South) which makes the pickup a single coil at high frequencies and a humbucker at lower frequencies. This produces a sound similar to a single coil but with a stronger, fuller tone and 50% less noise than COIL TAP mode.

HCP Connections

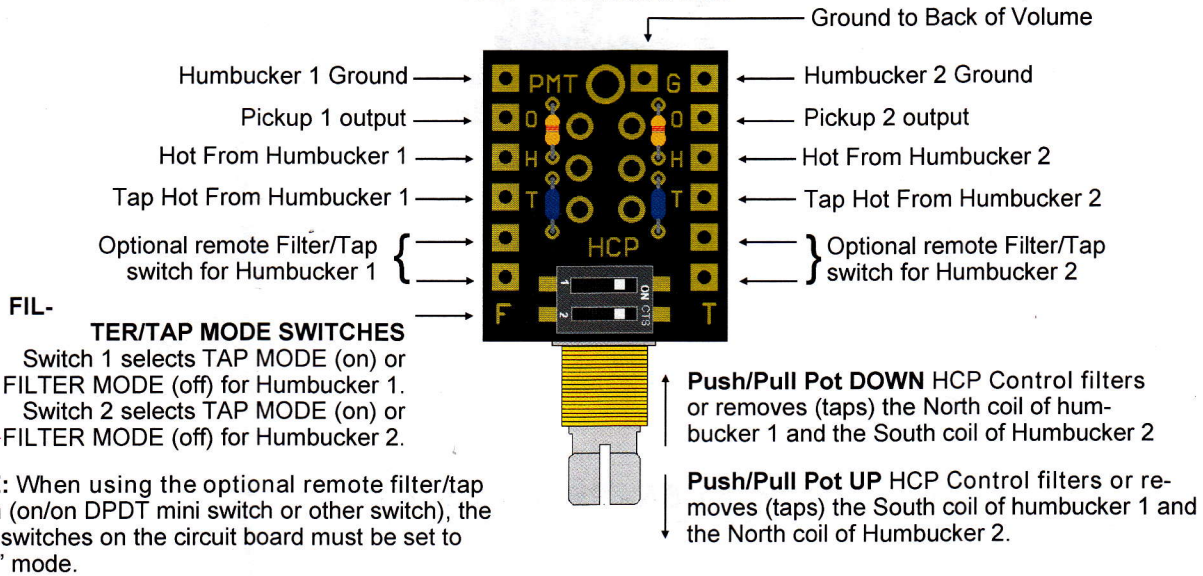

HCP Control w/ 2 Humbuckers, 2 Volumes & 1 Tone

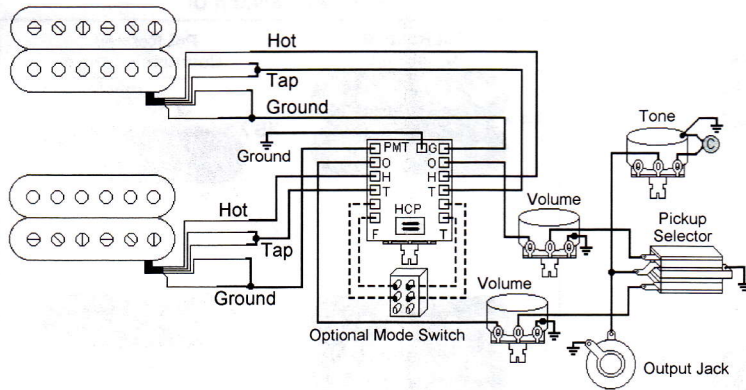

HCP Control w/ 2 Humbuckers, 1 Volume & 1 Tone

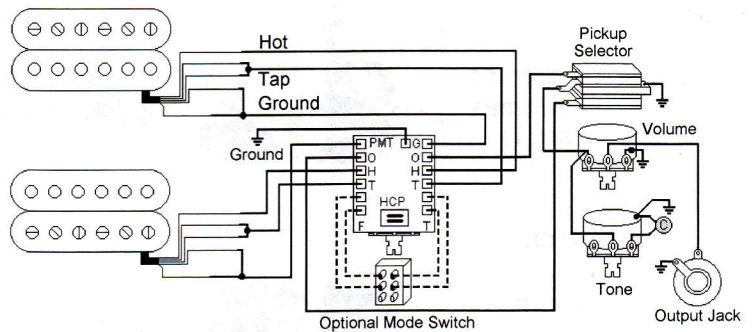

HCP Control w/ 2 Humbuckers, 1 Volume & 2 Tones

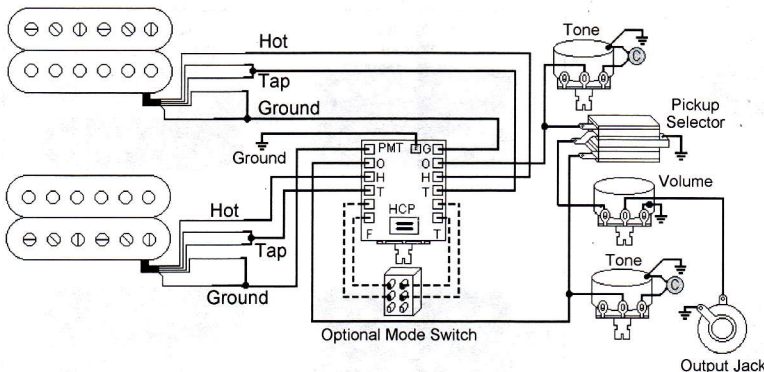

HCP Control w/ 1 Humbucker 1 Volume & 1 Tone

