

button. (Each time the button is pressed, inch and metric digits will be displayed alternatively).
 (3). Apply normal measuring pressure on slider to close the external measuring jaws. Then press "zero" button to reset the display to zero.

A. Measurements of external dimensions.

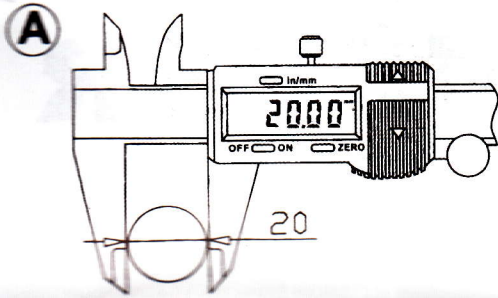

B. Measurements of internal dimensions.

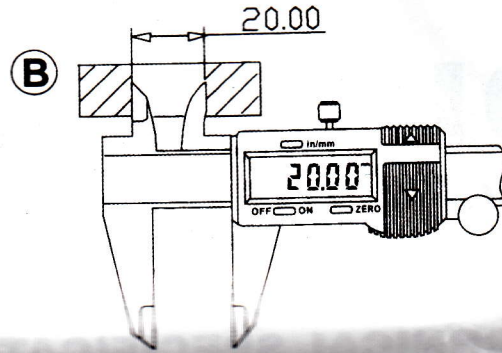

C. Measurements of steps.

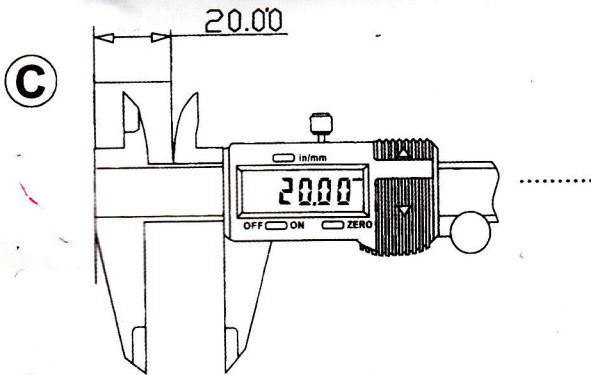

D. Measurements of depth.

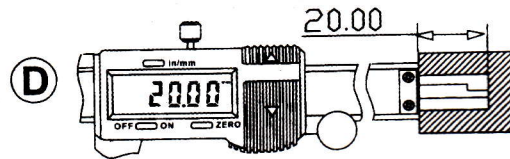

E. Differential method measurement
 (Application of zero setting)

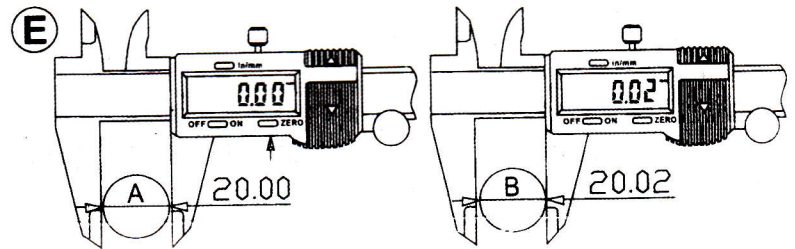

● MAINTENANCE INSTRUCTIONS

1. Keep the caliper clean and dry (Liquid can damage the slider)
2. Faces should be cleaned gently with cotton fabrics. Never use petrol, acetone and other organic solutions.
3. In order to save power, turn off the unit when caliper is going to stay idle for some time.
4. Never apply any electric pressure on any part of the caliper and never use an electronic pen for the fear of damaging its chip.
5. For other notes please refer to the conventional calipers.

● BATTERY REPLACEMENT

Flashing of digits shows a flat battery. Take off the battery cover in the direction shown by the arrow and replace the battery (positive side facing out).

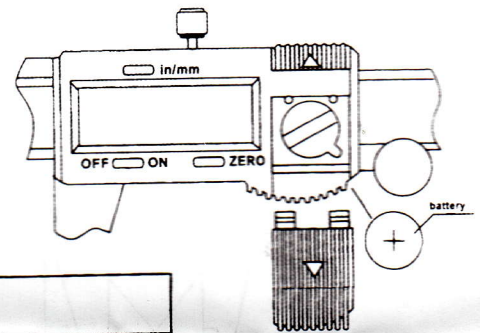

● TROUBLE SHOOTING

Failure	Cause	Measure
Five digits flash simultaneously, about once per sec.	Battery voltage lower than 1.45V.	Replace the battery.
Display doesn't change when the slider is moved	Accidental trouble in circuit	Take out battery and reset it after 30 sec.
Less accurate than specified but with $-in+0.1\text{mm}$.	Dirt in the sensor.	Remove slider cover and its assembly, clean compressed air (5kg/cm).
No display on LCD	1. Battery in poor contact. 2. Battery voltage under 1.4V.	1. Remove battery cover and adjust the battery seat, keep good connection. 2. Replace battery.