



345 Bayview Avenue, Amityville, New York 11701  
 For Sales and Repairs 1-800-ALA-LOCK  
 For Technical Service 1-800-645-9440  
 or visit us at <http://tech.napcosecurity.com/>

(Note: Technical Service is for security professionals only)  
 Publicly traded on NASDAQ Symbol: NSSC

© ALARM LOCK 2018

# NETWORXPANEL

## Wireless Networx™ Control Panel

### INSTALLATION INSTRUCTIONS

WI1856DLF 1/18

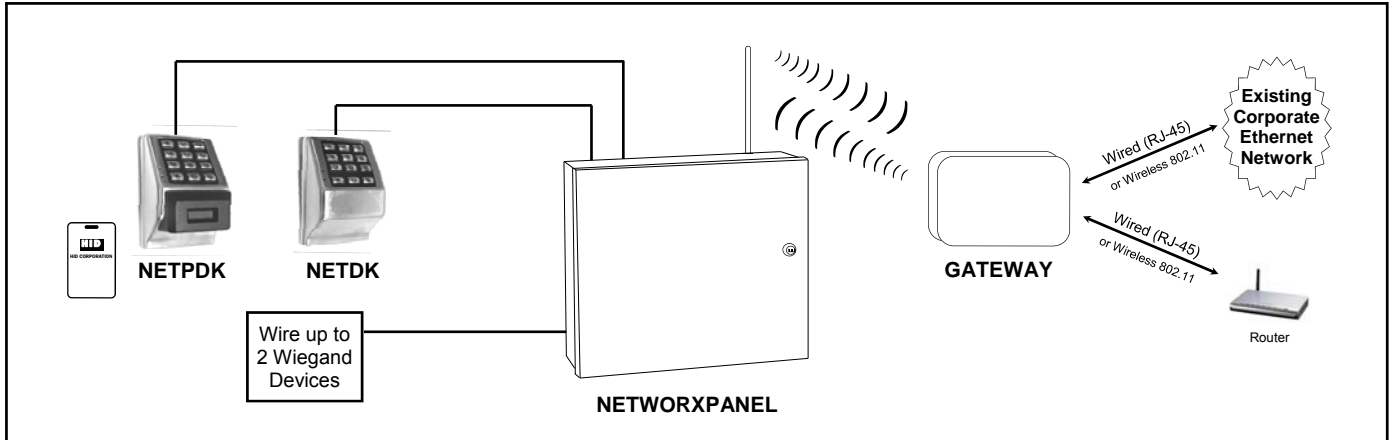

NETDK and/or NETPDK keypads (and/or Wiegand devices) wired to a dedicated NETWORKXPANEL control panel

## GENERAL DESCRIPTION

The NETDK keypad and NETPDK (keypad with proximity card reader) are secured single-door or double-door digital keypads for use within the wireless Networx™ system. These keypads are wired to the dedicated NETWORKXPANEL control panel and provide controlled access to a door by releasing a locking device (such as a magnetic lock or electric door strike) when a proper user code or proximity credential is presented.

The NETWORKXPANEL is capable of controlling two doors using up to two of any combination NETDK or NETPDK keypads or two Wiegand devices. In addition, the panel is equipped with two relays that can be independently assigned to either or both keypads. Thus the NETWORKXPANEL can be configured to allow a user to pass in both directions--or in only one direction--through a controlled door.

For example, a door can be configured to allow everyone to exit, but only a select few to enter. Log entries indicate the specific keypad used. For more information about the Networx system, see OI352.

**Note:** For the purposes of this manual, the word "keypad" refers to either the NETPDK model keypad or the NETDK model keypad.

Wiegand devices to separately control two doors, with one keypad is designated as the "primary" keypad controlling door number 1, and the other as the "secondary" keypad controlling door number 2;

- Two Form-C relays;
- Inputs for door position contact to indicate the status of the door, open or closed;
- Inputs for a remote release button or sensor;
- Onboard bi-directional Networx radio;
- Wiegand interface supports Wiegand device data, red LED, green LED, and sounder.

## FEATURES

The NETWORKXPANEL dedicated control panel contains:

- Circuit board with onboard flash memory;
- 12V power supply, with transformer and rechargeable back-up battery;
- Inputs supporting two of any combination of NETDK or NETPDK keypads, PLUS up to two Wiegand devices;
- Special "Two-Door Mode" allows two keypads and/or two

## TABLE OF CONTENTS

GENERAL DESCRIPTION.....	1
FEATURES .....	1
SPECIFICATIONS .....	1
WIEGAND DATA FORMATS SUPPORTED.....	2
LED AND BUTTON DESCRIPTIONS .....	2
TERMINAL DESCRIPTIONS .....	2
PLAN YOUR INSTALLATION .....	3
TYPICAL INSTALLATIONS .....	4
INSTALLATION STEPS .....	5
WIRING TWO KEYPADS TO THE NETWORKXPANEL .....	6
"TWO DOOR MODE" .....	6
<b>FIRST TIME POWER UP .....</b>	<b>7</b>
POWER RE-APPLIED .....	8
ERASE ALL PROGRAMMING.....	8
ENROLLING WIEGAND SWIPE CARDS .....	9
BASIC WIRING EXAMPLES .....	10
WIRING DIAGRAM .....	12
WARRANTY .....	12

## SPECIFICATIONS

### NETWORXPANEL

**Housing Dimensions (H x W x D):** 10.5 x 8.5 x 3 inches (26.6 x 21.6 x 7.6 cm)

**Operating Temperature:** 14-120°F (-10-49°C)

**Input Power:** 16.5VAC via UL Listed Class 2 Plug-In 50VA Transformer (supplied model TRF-14). Note: In Canada, replace with a cUL or CSA Listed Class 2 Plug-In 16.5VAC, 50VA transformer

**Maximum Lock Power Output Current:** 1.5A @ 12VDC

**Maximum Wiegand Power Output Current:** 250mA @ 12VDC

**Maximum Wiegand Red and Green LED Current:** 20mA each output

**Maximum Sounder Current:** 100mA

**Maximum Keypad Power Output Current:** 200mA @ 12VDC

**Primary and Secondary Relays:** SPDT Form C, N/O, N/C 8A @ 30VAC or VDC

**Backup Battery:** Use only a sealed UL Recognized Component Lead Acid 4AH or 7AH battery (max charge current 600mA. Verify battery max charge current, i.e. must be greater than 600mA). (Courant de charge maximum 600mA. Vérifier le courant de charge maximum de la batterie, c'est-à-dire doit être supérieur à 600 mA).

Replacing with an alternate size or type of battery can pose a risk of fire or explosion. Do not dispose of batteries into fire or a hot oven, or by mechanically crushing or cutting, or by any other means that can result in a risk of a fire or explosion. Do not expose the battery to extreme high or low temperatures

**Battery Backup Time:** Approximately 2 hours at full load (verify battery max discharge rate is greater than 2A). (Vérifier le taux de décharge maximum de la batterie est supérieur à 2A).

### NETDK / NETPDK Networx Keypads

**Power Requirements:** 12VDC supplied by NETWORXPANEL

**Idle Current:** 10mA

**Maximum Wire Length:** 200 feet (61m)

**Recommended Wire Size:** 24 AWG minimum

**Proximity Card Formats Supported:** Alarm Lock standard 36 bit format or HID standard 26 bit format (for use with the model NETPDK only)

## WIEGAND DATA FORMATS SUPPORTED

The NETWORXPANEL Wiegand inputs (terminals T4-T8) are compatible with all Wiegand devices that output their data in a "data1 / data0" format. If you are unsure of the compatibility of your Wiegand device data format, call Alarm Lock customer service (have your DL-Windows software version number available when calling).

### Wiegand Devices Supported

The NETWORXPANEL control panel has been tested to

work with the following Wiegand device models:

- HID Classic Swipe Wiegand Reader Model 310 (Continental 36-bit card format compatible).
- HID ProxPro with Keypad Model 5355
- HES Model RF5910 Hybrid Electric Strike with HID125k Reader

Note that other Wiegand device models not tested may also be fully compatible. For more information, see the section "**ENROLLING WIEGAND SWIPE CARDS**" further in this manual.

## LED AND BUTTON DESCRIPTIONS

The NETWORXPANEL PC board contains two LEDs and 1 button, as follows:

**(LD1) Activity LED:** Green LED located on the right side of the PC board; flickers during keypad data transfer.

**(LD2) AC Power LED:** Located on the left side of the PC board, this LED lights when the panel is powered (AC is present).

**(S2) Reset Button:** Located on the right side of the PC board; press and hold for 15 seconds to clear the NETWORXPANEL memory. **Note:** When memory is cleared, the green LD1 LED will flash once every second for 5 seconds. In addition, all keypad and device LEDs will flash once every second in unison. The keypad sounders and device sounders (if so equipped) will also sound in unison with the LED flashes.

**Note:** Although the **Reset** button will clear all NETWORXPANEL memory, if two NETPDK or NETDK keypads are wired to the NETWORXPANEL, the primary and secondary keypad designations will NOT be cleared; this keypad identification data is stored within the memory located inside the keypad itself. See the section "**Designate Primary and Secondary Keypads**" for the operation of this feature.

## TERMINAL DESCRIPTIONS

From left to right, the PC board terminals are as follows:

**(T1) EGND:** Wire earth ground using a No. 16 AWG. or larger wire to a metal cold-water pipe. Do not use a gas pipe, plastic pipe or AC ground connections. **NOTE:** Grounding connections should avoid bends in the grounding wire whenever possible.

**(T2-T3) AC IN:** Connect to the supply 16.5VAC transformer. Use 16AWG wire for shorter runs, and use 14AWG for longer runs. 25 feet maximum.

### (T4-T8) WIEGAND INPUTS

Two Wiegand devices are supported on the input terminals as detailed below.

**(T4) W0A:** If one Wiegand device is used, do not con-

nect any wires to this terminal; use the W0 terminal below.

If two Wiegand devices are used, connect the "Data 0" wire from the **second** Wiegand device to this terminal, (connect the "Data 0" wire from the **first** Wiegand device to the W0 terminal).

**(T5) W0:** If one Wiegand device is used, connect the "Data 0" wire to this terminal.

If two Wiegand devices are used, connect the "Data 0" wire from the **first** Wiegand device to this terminal (connect the "Data 0" wire from the **second** Wiegand device to the W0A terminal).

**(T6) W1:** If one Wiegand device is used, connect the "Data 1" wire to this terminal.

If two Wiegand devices are used, connect both Wiegand "Data 1" wires to this terminal.

**(T7) PWR:** If one Wiegand device is used, connect the "+ DC" power wire to this terminal.

If two Wiegand devices are used, connect both "+ DC" power wires to this terminal.

**(T8) GND:** If one Wiegand device is used, connect the ground wire to this terminal.

If two Wiegand devices are used, connect both ground wires to this terminal.

**(T9) RED LED:** Many Wiegand devices are equipped with a red LED for visual feedback. If the Wiegand device or devices are so equipped, connect the Wiegand red LED wire(s) to this terminal.

**(T10) GRN LED:** Many Wiegand devices are equipped with a green or green/red LED for visual feedback. If the Wiegand device or devices are so equipped, connect the Wiegand green LED wire(s) to this terminal.

**(T11) SNDR DRIVE:** Many Wiegand devices are equipped with a sounder for audio feedback. If the Wiegand device or devices are so equipped, connect the Wiegand sounder wire(s) to this terminal.

**(T12) KYPD PWR (+):** Connect the NETDK and/or NETPDK keypad red (+) power wire(s) to this terminal.

**(T13) KYPD PWR (-):** Connect the NETDK and/or NETPDK keypad black (-) ground wire(s) to this terminal.

**(T14) TX (YEL):** Connect the NETDK and/or NETPDK keypad yellow wire(s) to this terminal.

**(T15) RX (GRN):** Connect the NETDK and/or NETPDK keypad green wire(s) to this terminal.

**(T16-T18) AUX RELAY** Secondary Form C relay, 8A @ 24VAC / DC maximum:

**(T16) N/O:** Normally Open terminal

**(T17) N/C:** Normally Closed terminal

**(T18) COM:** Common terminal

**(T19) LOCK PWR (+):** High current power available to drive a locking device such as a magnetic lock or electric door strike; typically connected to the Common terminal for the device relay.

**(T20-T22) MAIN RELAY** Primary Form C relay, 8A @ 24VAC / DC maximum:

**(T20) COM:** Common terminal

**(T21) N/C:** Normally Closed terminal

**(T22) N/O:** Normally Open terminal

**(T23) LOCK PWR (-):** The common negative connection to the locking device (such as a magnetic lock or electric door strike).

**(T24-T25) DOOR POSITION CONTACT:** Connect to a door position contact (such as a magnet / contact reed switch or push button contact) to monitor the status of the access door. These terminals can be used for two purposes:

1. To detect if the door was left open after a User passes;
2. To detect if a closed and locked door is forcibly opened (door "kick-in").

The keypad sounder (or Wiegand device) can be programmed to announce an audible warning that a door is left open. If a door was left open after a User passes or for a door "kick-in", the door status is entered into the log as a "Door Ajar" entry. **Note:** The programmed Door Ajar Time begins after the programmed Pass Time ends (Pass Time settings are controlled by Functions 52-54; see the keypad programming instructions WI1855). In addition, the integral relay can be programmed to energize for this "Door Ajar" event (see Function 67 (feature #12) in the keypad programming instructions WI1855).

**(T26-T27) REMOTE RELEASE INPUT:** Connect to a remote release button or sensor to "unlock the door" to allow passage.

## PLAN YOUR INSTALLATION

Before installing your NETWORKXPANEL control panel, keypads and other devices, give careful consideration to the design and physical layout of the components. Plan in advance to ensure an efficient and complete installation. Be aware that the type of installation (see **TYPICAL INSTALLATIONS**) may greatly impact the wiring to (and programming of) the NETWORKXPANEL.

### Keypad Placement

The NETWORKXPANEL supports two of any combination of NETDK or NETPDK keypads, PLUS up to two Wiegand devices. Place keypads/devices within easy reach of the access door(s), to permit easy entry or exit.

### NETWORKXPANEL Placement

Inside the NETWORKXPANEL enclosure is a Network ra-

dio used to communicate with the Networx Gateway, therefore always mount the NETWORXPANEL enclosure with its antenna positioned vertically.

The NETWORXPANEL should be mounted in elevated areas. If mounting above drop ceilings, select an open area at least 6 inches away from the metal wires from which the drop-ceiling rail frames are suspended; do not mount close to electrical wiring or other metal obstructions such as pipes or conduits. Select a convenient location that allows access to a standard un-switched/uninterruptable 120VAC electrical outlet.

### Signal Strength Considerations

Choose a location as high above ground level as practical (home attic installations are *not* recommended), keeping in mind that metal objects may adversely affect radio operation. **Warning:** *Do NOT install the NETWORXPANEL in utility or computer closets as these locations have revealed acutely detrimental effects on signal strength.* Although wood and wallboard construction will have little effect upon signal strength, concrete or brick can reduce signal strength by up to 35%, while steel-reinforced concrete or metal lath and plaster can reduce NETWORXPANEL transmitter strength as much as 90%.

**Note:** In difficult installations wherein distant Gateways pose reception problems, the use of multiple Gateways throughout the premises is recommended.

### Wire Gauges

Locate the NETWORXPANEL in an easily accessible location for servicing, within 200 feet of the keypads and/or Wiegand devices. Standard 22-24 gauge wire is recommended for all connections between the NETWORXPANEL panel and the keypads/devices, and 18 gauge wire for all magnetic locks and electric door strikes (no more than 25 feet in length). Avoid running wires parallel to other types of wiring that can cause electrical interference.

### Air Circulation

**Important Note:** The NETWORXPANEL is powered by a linear power supply which is the preferred power supply for card proximity readers due to their very low electrical noise (compared with switching power supplies). However, be aware that linear power supplies do generate moderate heat. Therefore mount the NETWORXPANEL in a location that provides air circulation around the unit, *particularly directly above the housing*. Do not install the NETWORXPANEL in confined locations. **Note:** For UL installations, the NETWORXPANEL must be mounted within a protected premises.

### Fire Alarm System Integration

Before installing the Networx system, be sure to consult with the authority having jurisdiction to be sure to comply with all local codes. NFPA requires that the Fire Alarm System has some control over exit doors. In the event of a fire alarm or the loss of primary power (typically AC), all exit doors **must** be unlocked. Typically, the output(s) from the fire alarm system are wired such that if there is a fire alarm or AC failure of the fire alarm system, the positive (+) voltage wire of the magnetic lock is interrupted,

releasing the magnetic lock to allow egress. An emergency exit button mounted next to the door can also be used; this normally closed switch is wired in series to the positive (+) voltage wire of the magnetic lock so that when pressed, power is cut (interrupted) to the magnetic lock, allowing egress. **NEVER use the "(T26-T27) REMOTE RELEASE INPUT" terminals for emergency exit wiring.** Conform to the wiring examples shown further in this manual.

## TYPICAL INSTALLATIONS

There are several ways the NETWORXPANEL may be installed to provide access control. Before installing anything, be absolutely clear as to how the components will be installed, wired and how the NETWORXPANEL will be programmed. Listed below are some typical installations:

- **One Keypad only.** One of the simplest configurations is a single keypad or Wiegand device located outside the restricted area to allow passage through a controlled door in one direction only. This method uses the Main Relay to unlock the controlled door, leaving the Aux Relay unused or programmed for one of many other purposes (such as triggering a video camera to record the passage, or to trigger a bell located in another room).
- **One Keypad and One "Remote Release" Button.** With this configuration, a single keypad or Wiegand device is located outside the restricted area and a remote release button is placed within the restricted area. This method only requires a single keypad or Wiegand device for the controlled door. This method is limited in that the credential is identified in the log *only* for entry via the keypad, *not* for exit (the use of the remote release button is entered in the log but the identification of the person(s) exiting is not).
- **Two Wiegand Devices controlling one door:** Uses two Wiegand devices, one mounted inside and the other outside the restricted area. This configuration requires a User Code and/or proximity credential for both entry and exit from the restricted area. Each credential is logged with a specific Wiegand device identified, thus the credential used to enter or exit the restricted area can easily be determined.
- **Two Networx™ Keypads controlling one door:** Uses two of any combination keypad models, one mounted inside and the other outside the restricted area. This configuration requires a User Code (and/or proximity credential with the NETPDK integral proximity reader) for both entry and exit from the restricted area. Each credential is logged with a specific keypad identified ("primary" or "secondary"), thus the credential used to enter or exit the restricted area can easily be determined.
- **"Two-Door Mode":** Two Networx™ keypads (and/or two Wiegand devices) can be used to separately control two doors. With Two-Door Mode, one keypad is

designated as the "primary" keypad controlling the Main Relay (thus a primary door), and the other as the "secondary" keypad controlling the Aux Relay (thus a secondary door). To control passage through only one door, a specific User Code can be enabled for use with only one of the two keypads, therefore allowing control of only one of the two doors.

Although the physical wiring for Two-Door Mode is just as easy as any other type of configuration, both keypads must be wired to the same NETWORKXPANEL terminals; therefore one keypad must be designated as "primary" and the other as "secondary". In addition, the Two-Door Mode feature must be programmed (see WI1855 and program Function 67 (Feature 13, "Create Two-Door Mode"). These extra steps are incorporated in the "**FIRST TIME POWER UP**" procedure, so installing a two-door configuration will be just as easy as any other type of configuration.

## INSTALLATION STEPS

All inputs and outputs, electric door strikes, card readers and all other accessories should first be installed as detailed in the numbered steps below. **Note:** Do not apply power until all wiring is complete. Both AC and battery connections must be made before the NETWORKXPANEL will function properly. After the NETWORKXPANEL mounting location is selected, proceed as follows:

**1. Install the NETWORKXPANEL.** Mount the NETWORKXPANEL housing to a vertical surface indoors in a dry location (within the secured side of the door). The back-up battery must be located within the secure housing. Mount the housing using the two middle mounting holes and at least one bottom mounting hole.

**2. Install the Magnetic Lock(s) or Electric Door Strike(s).** Always mount the magnetic lock or electric door strike on the protected side of the door.

Before installation, always check with local laws having jurisdiction concerning the installation of magnetic locking devices. There may be strict limitations with regard the installation of magnetic or similar exit door locking devices. Local laws may require the installation of electrically separate panic hardware to ensure the door can be opened in the event of an emergency.

Door lock outputs can operate DC-powered locking devices such as magnetic door locks or other electro-mechanical locks and can be configured to operate in "Fail Secure" (which remain locked when power fails) or "Fail Safe" (which unlock when power fails) configurations.

**Example:** For normally energized door locks (such as a magnetic lock that locks the door when energized), connect ground to terminal T23, place a jumper wire between terminal 19 and terminal 20, then connect the positive door lock wire to terminal T21. See wiring diagrams for both normally energized and

de-energized door locks. The NETWORKXPANEL can supply a constant maximum 12VDC @ 1.5A. Relay contacts are rated 8A @ 30VAC or VDC.

### 3. Install Keypads and/or Wiegand Devices.

The NETDK and NETPDK keypads each have 4 wires (red, black, yellow and green); wire to terminals T12 through T15 as shown in the **BASIC WIRING EXAMPLES**. If two keypads are used, connect each wire in parallel (connect both keypad red wires to the same terminal T12, connect both keypad black wires to the same terminal T13, etc.) as shown in the wiring diagram. See WI1881 for keypad mounting instructions.

#### Wiegand Devices

Wiegand devices can be installed on one door (to control both entry and exit) or on two separate doors (to control access in one direction only). The text below indicates the correct wire / terminal connections for an example device, the "HID ProxPro with Keypad Model 5355" when only one device is wired to the NETWORKXPANEL:

<u>HID 5355 Wires</u>	<u>NETWORKXPANEL Terminals</u>
Red (DC+).....	(T7) PWR
Black (GND).....	(T8) GND
Green (Data "0").....	(T5) W0
White (Data "1").....	(T6) W1
Violet (DATA RTN) .....	(Not Used)
Orange (Green LED) .....	(T10) GRN LED
Brown (Red LED) .....	(T9) RED LED
Yellow (Beeper) .....	(T11) SNDR DRIVE
Blue (Hold) .....	(Not Used)
--- (COM).....	(Not Used)
--- (Tamper) .....	(Not Used)

See **SPECIFICATIONS** for supported Wiegand device models.

#### Wiegand Device LED and Sounder Indications (Optional)

Many Wiegand devices include an LED for visual feedback of system status or for visual feedback when access credentials are presented to or swiped in the reader. See the table above for examples of the variety of LED indications and their meanings. For the example device (HID ProxPoint Plus Model 6005B), wire the brown "Red LED" wire to terminal T9, wire the orange "Green LED" wire to terminal T10.

Many Wiegand devices include a sounder for audible feedback. Wire the sounder wire (some labeled "beeper") to terminal T11.

**4. Wire Door Position Contact.** Install a door position contact such as a magnet / contact reed switch or push button contact. This contact will monitor the status of the door (if door was left open or closed). Door contacts must be hardwired directly to the NETWORKXPANEL. Do not use wireless contacts. Wire to terminals T24 and T25. Door Position Contact is used to

detect if the door was left open after a User passes or to detect a door "kick-in" (if a closed and locked door is forcibly opened).

### Door Ajar

The keypad sounder (or Wiegand device) can be programmed to annunciate an audible warning that the Door Position Contacts have remained open past a certain programmed time. Typically, a door was left open after a User passed through the door, or a door "kick-in" occurred; in both of these examples, the door status is entered into the log as a "Door Ajar" entry. The NETWORXPANEL Aux Relay can be programmed to energize for this "Door Ajar" event (see Function 67 feature #12 in the keypad programming instructions WI1855). **Note:** The keypad (or sounder-equipped Wiegand device) used for passage will beep if the door was left open after a User passes; all keypads (or sounder-equipped Wiegand devices) will beep in the event of a door "kick in". **Note:** The programmed Door Ajar Time begins after the programmed Pass Time ends (Pass Time settings are controlled by Functions 52-54; see the keypad programming instructions WI1855).

- 5. Wire Remote Release button.** Install a normally open momentary switch or sensor mounted inside the restricted area; used to unlock the entry/exit door without requiring a keypad or Wiegand device. The normally open button or sensor is wired to the "Remote Release Input" terminals 26 and 27.

**Note:** Consult all installation instructions provided with each accessory before installation and connection to the NETWORXPANEL.

## WIRING TWO KEYPADS TO THE NETWORXPANEL

This section provides details as to the system operation when two of any combination DK model keypads (or one DK model keypad and one Wiegand device) are wired to the NETWORXPANEL. You can skip this section if **only one** keypad is wired to the NETWORXPANEL, or if **no** keypads are used and **only** Wiegand devices wired to the NETWORXPANEL.

- **Two keypads can be used to control one door;** the Main Relay will be wired to a locking device, leaving the Aux Relay available to be used for a variety of purposes.
- **Two keypads can be used to control two doors;** "Two-Door Mode" must be programmed, forcing the primary keypad to activate the Main Relay only and the secondary keypad to activate the Aux Relay only. All previously programmed Aux Relay functions will be erased.

Because both keypads are wired to the same terminals, when using two keypads, the rule is:

*When two keypads are wired to the same NETWORXPANEL terminals, one keypad must be designated as "primary" and the other as "secondary".*

**Note:** If planning to use "High Security Mode" (both a User Code and proximity credential required for passage), *both keypads installed MUST be NETPDK model keypads (if using Wiegand devices, both must be equipped with combination keypad and proximity reader).* See the section "**WIEGAND DATA FORMATS**" for supported Wiegand Devices.

### Designate "Primary" and "Secondary"

As stated above:

*When two keypads are wired to the same NETWORXPANEL terminals, one keypad must be designated as "primary" and the other as "secondary".*

All keypads are set at the factory as "primary"; therefore only one of the two keypads will need to be designated as "secondary". To change a "primary" keypad to "secondary" (or a "secondary" back to "primary"), the keypad must first be powered (wired to the NETWORXPANEL and powered), then the procedure in step 4 of "**FIRST TIME POWER UP**" must be performed.

### Two Keypad Identification Feature

To clarify which keypad is programmed as the "primary" or the "secondary", each keypad can be made to self-identify. With the keypad fully powered, perform the following:

*Press and hold any numbered keypad key between 2-9 for 5 seconds, and its LED will flash either once (indicating that keypad is programmed as primary) or twice (indicating that keypad is programmed as secondary).*

### Two-Door Mode

Two-Door Mode is used to separately control two doors with two of any combination NETDK / NETPDK keypads (or compatible Wiegand devices) wired to one NETWORXPANEL. With Two-Door Mode, one keypad is designated as the "primary" keypad (controlling the Main Relay wired to door number 1), and the other as the "secondary" keypad (controlling the Aux Relay wired to door number 2). A specific User Code can be enabled for use with only one of the two keypads, therefore allowing passage through only one of the two doors. If the keypads are mounted to opposite sides of the same two-way swinging door, passage through the door will be allowed in only one direction.

## Two-Door Mode Wiring

The physical wiring for Two-Door Mode is just as easy as any other type of configuration, with both keypads wired to the same NETWORKXPANEL terminals. If using compatible Wiegand devices, be sure to use the correct terminals (T4-T8). See the section "**TERMINAL DESCRIPTIONS**" and the wiring diagram.

## Two-Door Mode Programming

To configure the system for "Two-Door Mode", see W11855 and program Function 67 (Feature 13, "Create Two-Door Mode"). When programmed, all existing auxiliary relay features (if programmed) are erased, and the "primary" keypad activates the Main Relay (wired to door 1), and the secondary keypad activates the Aux Relay (wired to door 2).

Finally, using the procedure in step 4 of "**FIRST TIME POWER UP**", one of the two keypads will need to be designated as "secondary", because the rule is:

*When two keypads are wired to the same NETWORKXPANEL terminals, one keypad must be designated as "primary" and the other as "secondary".*

## Two-Door Mode Aux Relay

When Two-Door Mode is *not* programmed, the Auxiliary Relay is available to be used for a variety of purposes. With the Main Relay dedicated to operating the door locking device, the Aux Relay is available to be programmed to trigger a bell, a light, a video camera, or any other type of device provided the power limits of the relay are not exceeded (see **SPECIFICATIONS**). When Two-Door Mode *is* programmed, all Aux Relay features (if programmed) are erased; *the primary keypad will then activate the Main Relay only and the secondary keypad will activate the Aux Relay only.*

## Two-Door Mode Important Reminder

As stated previously, Two-Door Mode is used to separately control two doors with two keypads wired to one NETWORKXPANEL. **Note:** The default settings of Two-Door Mode are the settings that are in effect when Function 67 feature 13 is enabled, and no other Function 67 features are enabled.

Although from one perspective it appears that two separate keypads exist in the installation, from the perspective of the NETWORKXPANEL (or from DL-Windows), two keypads do NOT exist; *there is only ONE "Lock Program"*. Therefore, *when in Two-Door Mode, except for User Codes, all lock-based timing features and Functions apply to the one NETWORKXPANEL "Lock Program" and therefore both relays on the NETWORKXPANEL (except when Function 67, feature 51 or 52 is enabled; see the keypad programming instructions W11855 for details).* **Note:** "Keypad Lockout" (Functions 60-61) only applies to the individual keypad responsible (see W11855).

Refer to W11855 for the following examples:

**Example 1:** In the default Two-Door Mode, if Function 45 "Enable Passage Mode" is programmed, Passage

Mode will apply to BOTH relays and thus BOTH doors, even though the Function was programmed at only one of the two keypads. (If you wish to control each door separately, see W11855 and use Function 67, feature 51 or 52).

**Example 2:** In the default Two-Door Mode, programming Function 54 "Set Pass Time to 15 Seconds" will always apply to BOTH keypads, and thus BOTH doors.

**Example 3:** In the default Two-Door Mode, programming Function 69 "Enable  as Enter Key" will affect BOTH keypads, and thus all User Codes stored in the NETWORKXPANEL.

**Example 4:** In the default Two-Door Mode, programming Function 72 "Schedule Enable Passage Mode (Unlock)" will affect BOTH keypads, BOTH Relays, and thus BOTH doors, even though this Function may have been programmed at only one of the keypads. (If you wish to control each door separately, see W11855 and use Function 67, feature 51 or 52).

**DL-Windows:** The NETWORKXPANEL can have two keypads, controlling two doors, with two additional Wiegand devices wired; but be aware that DL-Windows will interpret and display this complex system as a single NETWORKXPANEL (the same as if the NETWORKXPANEL were a single wireless door lock, such as a PDL6100 cylindrical lockset mounted to a door).

## FIRST TIME POWER UP

If applying power to the NETWORKXPANEL, keypads and/or Wiegand devices that were previously powered and operational, and you wish to retain all existing programming, go to the next section "**POWER RE-APPLIED**".

Before applying power, all electric door strikes, magnetic locks, Wiegand devices, keypads and all other accessories must first be wired to the NETWORKXPANEL terminals as detailed in the steps above and as indicated in the wiring diagram.

1. Plug the transformer into a standard un-switched/uninterruptable 120VAC electrical outlet.

**Initially**, all connected NETDK and NETPDK keypads will sound two beeps (connected Wiegand keypads will typically sound a single long startup beep, depending on the manufacturer). The NETWORKXPANEL will command each keypad to output the standard three startup beeps, a "15-second waiting period" (do not press any keys during this time) followed by a set of rapid beeps when the keypads are ready (these beeps are characteristic of all Network and T3 series devices). **Note:** During this "15-second waiting period", NETWORKXPANEL Firmware V64t adds two separate RED LED pulses.

In addition, the green **LD1** "Activity" LED (located on the **right** side of the PC board) will flash with each beep, thus confirming a proper cold power up of the NETWORKXPANEL. **Note:** If these flashes and

beeps do not occur, restart the NETWORXPANEL by removing power, press and hold the **Reset** button (S2) located on the right side of the PC board for 15 seconds to discharge the power supply, then retry at step 1.

2. Connect the battery flying leads, carefully observing polarity.
3. **IMPORTANT:** Press and hold the **Reset** button (S2) located on the right side of the PC board for 15 seconds to clear the NETWORXPANEL memory.

While memory is being cleared, the green LD1 "Activity" LED (located on the **right** side of the PC board) will flash once every second for 5 seconds. In addition, all keypad and Wiegand device LEDs will flash once every second in unison. The keypad sounders and Wiegand device sounders (if so equipped) will also sound in unison with the LED flashes.

4. **Select "primary" or "secondary" keypad designations.** If two keypads are wired to one NETWORXPANEL, follow this step; if only one keypad is wired, or none are wired (therefore only Wiegand device(s) are used), skip this step and go to step 5.

As detailed in step 1, upon applying power to the keypads, two beeps are heard from the keypad(s). These two beeps indicate that a 10-minute "startup timer" begins whereby the "primary" and "secondary" keypad designations can be selected.

After power is applied and the two beeps have sounded, at one of the two keypads press and hold  until a series of beeps are heard, then release the button—you have 15 seconds to make the keypad designation by simply *pressing either* the "1" button for "primary" or the "2" button for "secondary". Two short confirmation chirps will be heard. To summarize the steps:

- a. Apply power to keypad, hear two keypad beeps (start of 10-minute "startup timer").
- b. Press and hold  until a series of beeps are heard (release button); beeps indicate you have 15 seconds to perform the next step...
- c. Press the "1" button (for "primary") or the "2" button (for "secondary"); two short confirmation chirps sound. Done!

**If the 10-minute "startup timer" expires:** If the keypad is powered and the two beeps sound from the keypad, but the 10-minute timer expires without any buttons pressed, no changes will be made to the keypad, thus the pre-existing (pre-power up) keypad designation will be preserved. To re-start the 10-minute "startup timer", you must remove power from the keypad(s) and re-apply power (disconnect wires from the power source and re-connect).

**If the 15 Second Timer Expires:** If you press and hold  with the series of beeps heard (and release the button), and no further buttons are pressed, a short chirp will sound to indicate your 15

second timer expired. Simply repeat the process by pressing and holding  until the series of beeps are heard. You can keep repeating this until your initial 10-minute "startup timer" expires.

**Note:** Another way to start the 10-minute "startup timer" is to download firmware to the keypads (see OI352 for firmware download instructions). If two keypads are wired to the NETWORXPANEL, always make the "primary" or "secondary" keypad designation selections first, then download firmware.

**IMPORTANT:** When updating the keypad firmware, the NETWORXPANEL firmware must also be updated (and vice-versa). **Note:** If two keypads are installed, both will be automatically updated during the update process.

5. If a NETPDK keypad is installed, present any kind of proximity credential (enrolled or un-enrolled) to the NETPDK reader. This action will inform the NETWORXPANEL firmware that the keypad wired to the NETWORXPANEL is a NETPDK model keypad.
6. The NETWORXPANEL is ready to be discovered by the Networx system Gateway. See OI352 for complete step-by-step discovery instructions.

## POWER RE-APPLIED

For keypads that were already powered and operational: If one or two keypad wires are disconnected from the NETWORXPANEL terminals (T12-T15), and then re-connected (and power re-applied), each keypad will simply resume its operation with the NETWORXPANEL. The keypad "primary" and "secondary" designations will NOT be cleared (these keypad designations are stored within the memory located inside each keypad). Therefore, if both keypads are removed from their mounting locations, we recommend temporarily labeling each keypad to avoid confusion when re-mounting.

## ERASE ALL PROGRAMMING

To erase both the NETWORXPANEL memory and the NETDK or NETPDK keypad memory, thus restoring the "out of box" factory default for each, proceed as follows:

### Erase NETWORXPANEL Memory

Press and hold the Reset button (S2) located on the right side of the PC board for 15 seconds to clear the NETWORXPANEL memory.

When memory is cleared, the green LD1 "Activity" LED (located on the right side of the PC board) will flash once every second for 5 seconds. In addition, all keypad and device LEDs will flash once every second in unison. The keypad sounders and device sounders (if so equipped) will also sound in unison with the LED flashes.

### Erase Keypad Memory

**Note:** Function 99 (see the keypad programming



instructions WI1855) will NOT restore the keypad to its "out of box" factory default state.

The keypads do not contain programming data within their electronic circuitry except for the "primary" or "secondary" designations (detailed in the section "**WIRING TWO KEYPADS TO THE NETWORK-PANEL**"). All keypads leave the factory as "primary" keypads, thus the keypad designated as "primary" in a two keypad installation *is already in its factory default state*. For a keypad designated as "secondary" or when you are unsure of the keypad designation, restore the factory default "primary" designation as follows:

1. Power the keypad by connecting the red wire to any +12V power source (and connect the black wire to the common negative). If you wish, connect to the NETWORKPANEL terminals (red wire to terminal T12, black wire to T13).

2. The keypad will sound two beeps when powered.

These two beeps indicate that a 10-minute "startup timer" begins whereby the "primary" and "secondary" keypad designations can be selected.

After power is applied and two beeps have sounded, press and hold  until a series of beeps are heard, then release the button—you have 15 seconds to make the keypad designation by simply *pressing either* the "1" button (for "primary") or the "2" button (for "secondary"). Two short confirmation chirps are heard. To summarize the steps:

#### Summary:

- a. Apply power to keypad, hear two keypad beeps (start of 10-minute "startup timer").
- b. Press and hold  until a series of beeps are heard (release button); beeps indicate you have 15 seconds to perform the next step...
- c. Press the "1" button (for "primary") or the "2" button (for "secondary"); two short confirmation chirps sound. Done!

**If the 10-minute "startup timer" expires:** If the keypad is powered and the two beeps sound from the keypad, but the 10-minute timer expires without any buttons pressed, no changes will be made to the keypad, thus the pre-existing (pre-power up) keypad designation will be preserved. To re-start the 10-minute "startup timer", you must remove power from the keypad(s) and re-apply power (disconnect wires from the power source and re-connect).

**If the 15 Second Timer Expires:** If you press and hold  with the series of beeps heard (and re-

lease the button), and no further buttons are pressed, a short chirp will sound to indicate your 15 second timer expired. Simply repeat the process by pressing and holding  until the series of beeps are heard. You can keep repeating this until your initial 10-minute "startup timer" expires.

**Note:** Another way to start the 10-minute "startup timer" is to download firmware to the keypads (see OI352 for firmware download instructions). In addition, do not download the same firmware to keypads with the same "primary" or "secondary" keypad designations; always make the keypad designation selections first, then download firmware.

**IMPORTANT:** When updating the keypad firmware, the NETWORKPANEL firmware must also be updated (and vice-versa). **Note:** If two keypads are installed, both will be automatically updated during the update process.

## ENROLLING WIEGAND SWIPE CARDS

When enrolling Wiegand swipe cards, DL-Windows and a compatible reader **MUST** be used; the NETPDK keypad cannot "read" Wiegand swipe cards. See **SPECIFICATIONS** for supported Wiegand reader device models.

Be aware that the "printed number" or "hot stamped" number seen on the surface of the card may not be the same as the "embedded card number" stored within the card's data stream (DL-Windows requires the "embedded card number" when enrolling). In addition, *both of these numbers may not be mutually sequential* (cards physically ordered sequentially by their "printed numbers" may not necessarily have their "embedded card numbers" also sequential). The "embedded card number" may be printed on a reference data sheet provided by the manufacturer. Therefore, the "Sequential Add" utility (see OI237) may not be used with Wiegand swipe cards.

The "Facility Code" provided by the manufacturer may be in either decimal or hexadecimal notation. In addition, the manufacturer may not indicate the notation used. A scientific calculator can be used to make the conversion, if necessary. Note that all entries into DL-Windows must be in decimal notation.

"High Security Access" (both a card "swipe" input and User Code input required) may **not** be used with Wiegand devices, unless both are equipped with combination keypad and proximity reader. See the section "**WIEGAND DATA FORMATS**" for supported Wiegand devices.

# BASIC WIRING EXAMPLES

## One Door / One Keypad / Magnetic Lock or Electric Door Strike

As shown below, the Magnetic Lock and Fail-Safe Electric Door Strike wiring are identical. **Do NOT use Fail-Secure devices for fire exit doors!** In the event of power loss, Fail-Secure devices remain "secure" (locked).

The keypad interrupts MAG LOCK (or Fail-Safe Electric Door Strike) power upon a successful User Code entry (or Prox Card presentation), initiating "Pass Time" (time the door remains unlocked). The default Pass Time is 3 seconds, but you can change this time to 10 or 15 seconds using Functions 52-54 (see the keypad programming instructions WI1855).

**TSD** = Transient Suppression Device (two supplied): Mount the TSD as close to the device to be protected as possible.

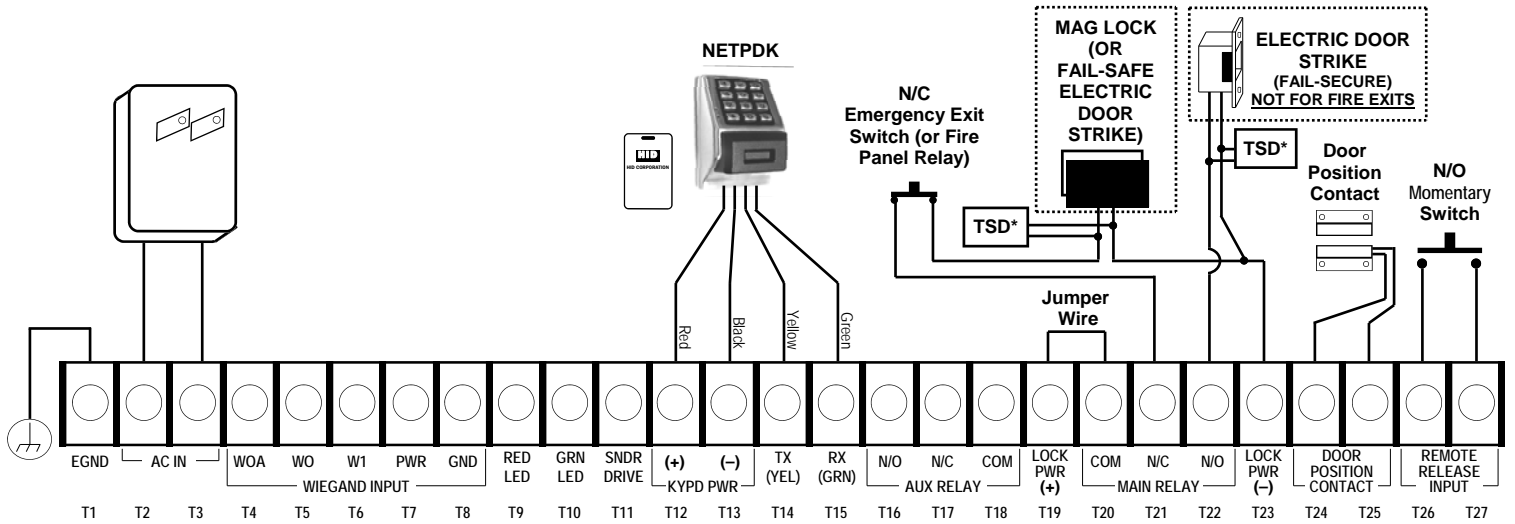

## One or Two Doors / Two Keypads or Two Wiegand Devices Magnetic Lock and/or Electric Door Strike

The system is capable of controlling two doors using up to two of any combination of NETDK or NETPDK keypads, PLUS up to two Wiegand devices. Two auxiliary Form-C relays are available for up to two of any combination of magnetic locks and/or electric door strikes.

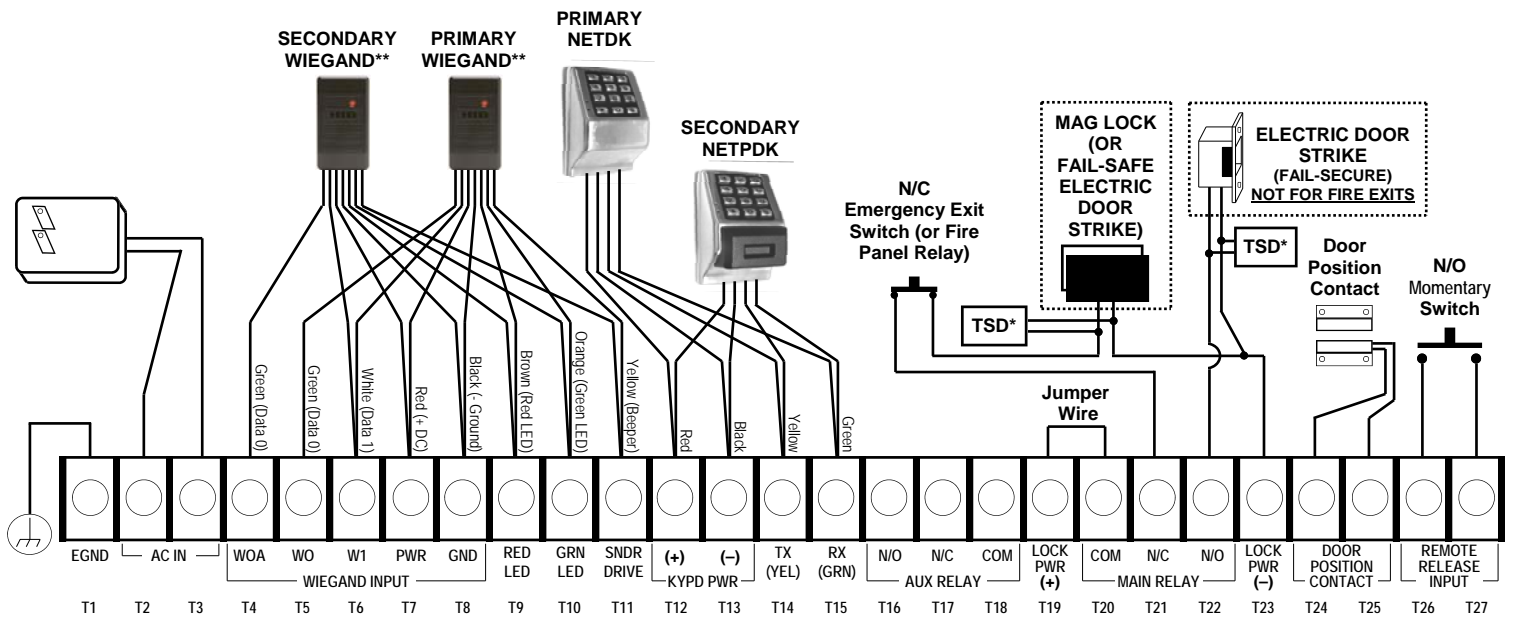

\*TSD = Transient Suppression Device (two supplied): Mount the TSD as close to the device to be protected as possible.

\*\*Example device shown: HID ProxPoint<sup>®</sup> Plus Model 6005B.

# NETWORXPANEL WIRING DIAGRAM

UL R/C Lead Acid  
4AH or 7AH  
Rechargeable  
Battery +12V.

E3  $\diamond$  (+) RED  
E4  $\diamond$  (-) BLACK

GREEN  
AC POWER LED  
LD2



1. ALL OUTPUT TERMINAL VOLTAGES ARE 12VDC.
2. MAXIMUM LOCK CURRENT (TERMINAL T19): 1.5A CURRENT LIMITED.
3. BATTERY STANDBY TIME: 2 HOURS AT MAXIMUM LOAD AND 4AH BATTERY.
4. UNIT INTENDED TO BE MOUNTED WITH ANTENNA POINTED VERTICALLY.
5. RECOMMENDED LEAD ACID BATTERIES: YUASA NP-4-12 AND NP7-12. LEAD ACID BATTERIES MUST BE REPLACED EVERY 5 YEARS.
6. CAUTION: "RISK OF EXPLOSION IF THE BATTERY IS REPLACED BY AN INCORRECT TYPE." "RISQUE D'EXPLOSION SI LA BATTERIE EST REMPLACÉE PAR UN TYPE INCORRECT."

GREEN  
ACTIVITY LED  
LD1



COLD WATER GROUND  
CONNECTION  
USE ONLY COLD-WATER PIPE  
OR BURIED GROUND ROD.  
USE AT LEAST #16 AWG WIRE

AC IN, 16.5V/60HZ VIA TRF14  
CLASS 2 TRANSFORMER. DO  
NOT CONNECT TO SWITCHED  
OUTLET. NE PAS BRANCHER LA  
LA SORTIE COMMUTÉE.

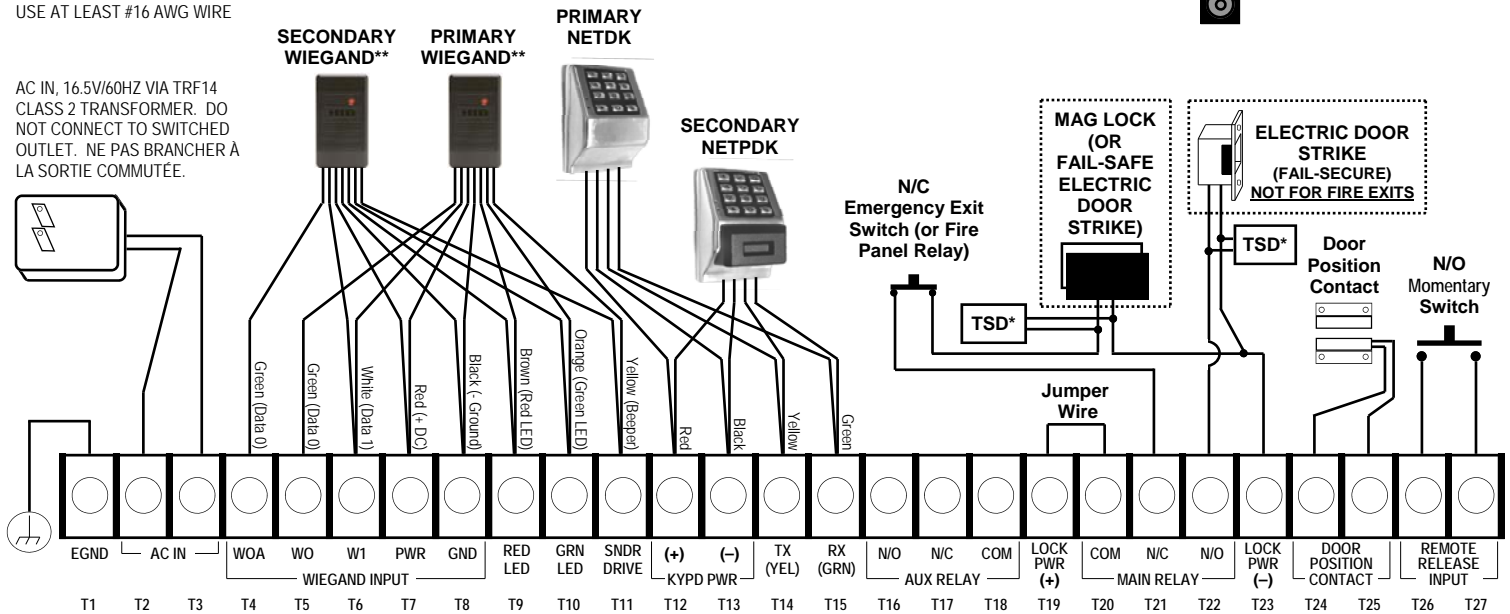

\*TSD = Transient Suppression Device (two supplied): Mount the TSD as close to the device to be protected as possible.

\*\*Example device shown: HID ProxPoint® Plus Model 6005B.

**IMPORTANT:** When updating the keypad firmware, the NETWORXPANEL firmware MUST ALSO be updated (and vice-versa).  
**Note:** If two keypads are installed, both will be automatically updated during the update process.

# ALARM LOCK LIMITED WARRANTY

ALARM LOCK SYSTEMS, INC. (ALARM LOCK) warrants its products to be free from manufacturing defects in materials and workmanship for twenty four months following the date of manufacture. ALARM LOCK will, within said period, at its option, repair or replace any product failing to operate correctly without charge to the original purchaser or user.

This warranty shall not apply to any equipment, or any part thereof, which has been repaired by others, improperly installed, improperly used, abused, altered, damaged, subjected to acts of God, or on which any serial numbers have been altered, defaced or removed. Seller will not be responsible for any dismantling or reinstallation charges, environmental wear and tear, normal maintenance expenses, or shipping and freight expenses required to return products to ALARM LOCK. Additionally, this warranty shall not cover scratches, abrasions or deterioration due to the use of paints, solvents or other chemicals.

THERE ARE NO WARRANTIES, EXPRESS OR IMPLIED, WHICH EXTEND BEYOND THE DESCRIPTION ON THE FACE HEREOF. THERE IS NO EXPRESS OR IMPLIED WARRANTY OF MERCHANTABILITY OR A WARRANTY OF FITNESS FOR A PARTICULAR PURPOSE. ADDITIONALLY, THIS WARRANTY IS IN LIEU OF ALL OTHER OBLIGATIONS OR LIABILITIES ON THE PART OF ALARM LOCK.

Any action for breach of warranty, including but not limited to any implied warranty of merchantability, must be brought within the six months following the end of the warranty period.

IN NO CASE SHALL ALARM LOCK BE LIABLE TO ANYONE FOR ANY CONSEQUENTIAL OR INCIDENTAL DAMAGES FOR BREACH OF THIS OR ANY OTHER WARRANTY, EXPRESS OR IMPLIED, EVEN IF THE LOSS OR DAMAGE IS CAUSED BY THE SELLER'S OWN NEGLIGENCE OR FAULT.

In case of defect, contact the security professional who installed and maintains your security system. In order to exercise the warranty, the product must be returned by the security professional, shipping costs prepaid and insured to ALARM LOCK. After repair or replacement, ALARM LOCK assumes the cost of returning products under warranty. ALARM LOCK shall have no obligation under this warranty, or otherwise, if the product has been repaired by others, improperly installed, improperly used, abused, altered, damaged, subjected to accident, nuisance, flood, fire or acts of God, or on which any serial numbers have been altered, defaced or removed. ALARM LOCK will not be responsible for any dismantling, reassembly or reinstallation charges, environmental wear and tear, normal maintenance expenses, or shipping and freight expenses required to return products to ALARM LOCK. Additionally, this warranty shall not cover scratches, abrasions or deterioration due to the use of paints, solvents or other chemicals.

This warranty contains the entire warranty. It is the sole warranty and any prior agreements or representations, whether oral or written, are either merged herein or are expressly cancelled. ALARM LOCK neither assumes, nor authorizes any other person purporting to act on its behalf to modify, to change, or to assume for it, any other warranty or liability concerning its products.

In no event shall ALARM LOCK be liable for an amount in excess of ALARM LOCK's original selling price of the product, for any loss or damage, whether direct, indirect, incidental, consequential, or otherwise arising out of any failure of the product. Seller's warranty, as hereinabove set forth, shall not be enlarged, diminished or affected by and no obligation or liability shall arise or grow out of Seller's rendering of technical advice or service in connection with Buyer's order of the goods furnished hereunder.

ALARM LOCK RECOMMENDS THAT THE ENTIRE SYSTEM BE COMPLETELY TESTED WEEKLY.

**Warning:** Despite frequent testing, and due to, but not limited to, any or all of the following; criminal tampering, electrical or communications disruption, it is possible for the system to fail to perform as expected. ALARM LOCK does not represent that the product/system may not be compromised or circumvented; or that the product or system will prevent any personal injury or property loss by burglary, robbery, fire or otherwise; nor that the product or system will in all cases provide adequate warning or protection. A properly installed and maintained alarm may only reduce risk of burglary, robbery, fire or otherwise but it is not insurance or a guarantee that these events will not occur. CONSEQUENTLY, SELLER SHALL HAVE NO LIABILITY FOR ANY PERSONAL INJURY, PROPERTY DAMAGE, OR OTHER LOSS BASED ON A CLAIM THE PRODUCT FAILED TO GIVE WARNING. Therefore, the installer should in turn advise the consumer to take any and all precautions for his or her safety including, but not limited to, fleeing the premises and calling police or fire department, in order to mitigate the possibilities of harm and/or damage.

ALARM LOCK is not an insurer of either the property or safety of the user's family or employees, and limits its liability for any loss or damage including incidental or consequential damages to ALARM LOCK's original selling price of the product regardless of the cause of such loss or damage.

Some states do not allow limitations on how long an implied warranty lasts or do not allow the exclusion or limitation of incidental or consequential damages, or differentiate in their treatment of limitations of liability for ordinary or gross negligence, so the above limitations or exclusions may not apply to you. This Warranty gives you specific legal rights and you may also have other rights which vary from state to state.