

5' INSTRUCTOR DESK

1214-L, 1214-R, 1214F-L, 1214F-R, 1216-L, 1216-R, 1216F-L & 1216F-R SERIES
ASSEMBLY INSTRUCTIONS

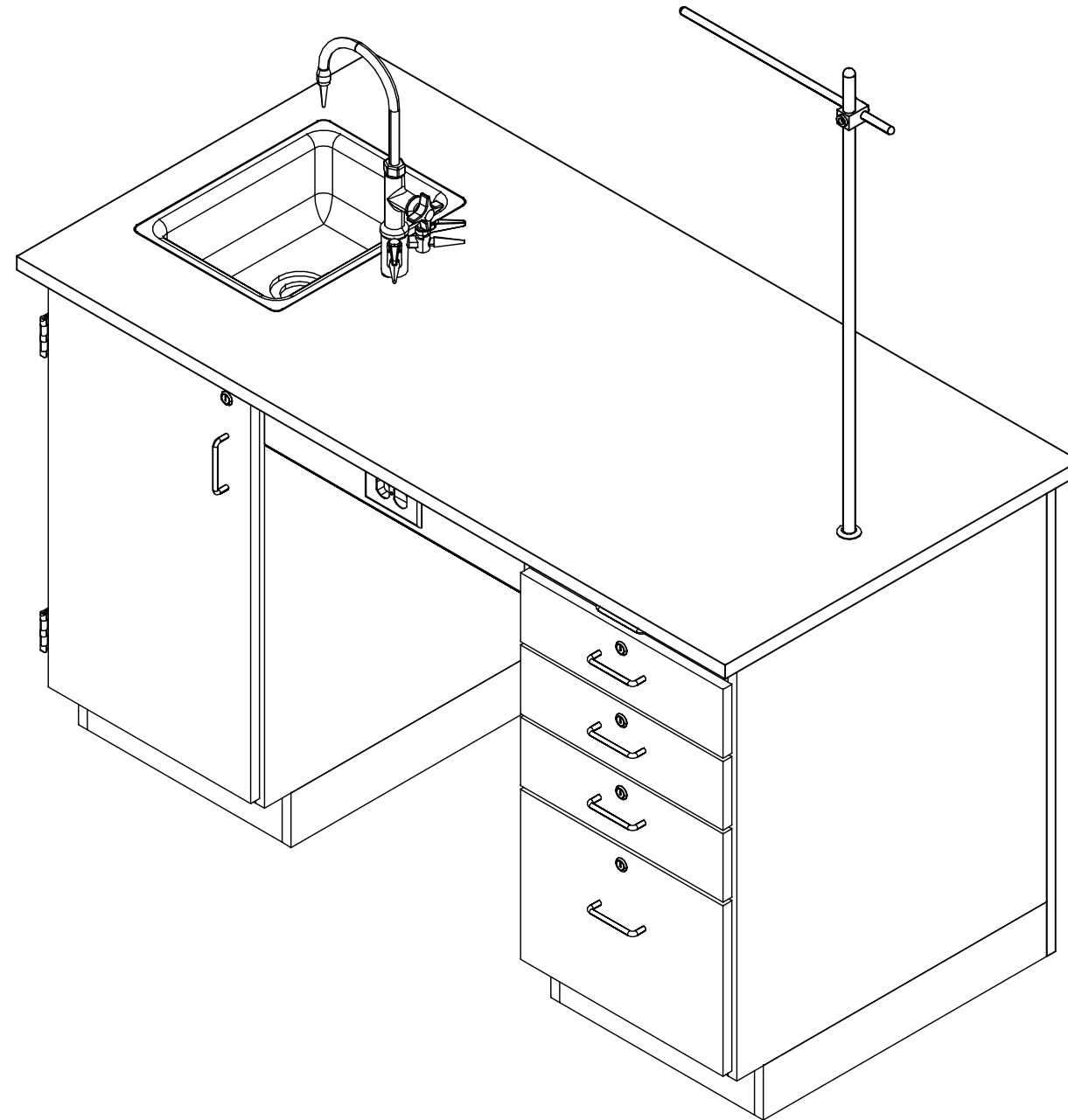

NOTE:

1. MODEL VIEWS MAY NOT REPRESENT EXACT MODEL PURCHASED

REV.	DESCRIPTION	DATE	NAME	ECN NO.
C	UPDATED SILICONE PROCEDURE	8/16/23	RJM	-
A	CREATED DRAWING	11/9/16	EMR	-
REVISION LEVEL				

ALL DIMENSIONS ARE IN INCHES UNLESS NOTED OTHERWISE DECIMALS: .X = ± .030 .XX = ± .020 .XXX = ± .010 ANGLES: = ± 1° CABINET SQUARENESS = ± .0625	DWN BY:	EMR	DATE DWN:	11/9/16
	APR BY:		DATE APR:	
	APR BY:		DATE APR:	
	APR BY:		DATE APR:	

CONFIDENTIAL:
ALL DESIGN RIGHTS RESERVED.
THE INFORMATION, DATA, DESIGN, AND DRAWINGS EMBODIED IN THIS DOCUMENT AND ALL REPRODUCTIONS THEREOF ARE THE EXCLUSIVE PROPERTY OF DIVERSIFIED WOODCRAFTS, INC.

THESE DOCUMENTS ARE SUPPLIED WITH THE UNDERSTANDING THAT THEY WILL NOT BE DISCLOSED TO THIRD PARTIES WITHOUT WRITTEN CONSENT OF DIVERSIFIED WOODCRAFTS, INC. ANY REPRODUCTION IN PART OR WHOLE WITHOUT WRITTEN CONSENT IS SUBJECT TO LEGAL ACTION.



300 South Krueger Street
Suring, WI 54174
diversifiedwoodcrafts.com

TITLE:
**5' INSTRUCTOR DESK
ASSEMBLY INSTRUCTIONS**

DRAWING NUMBER:	SCALE:	SHEET:	REVISION:
1214 & 1214F, 1216 & 1216F	NTS	1 OF 14	REV C

TOOLS REQUIRED

CONTACT CEMENT
SCREW DRIVER
C-CLAMPS
SHIM STOCK (IF NEEDED)

ASSEMBLY COMPONENTS

ITEMS INCLUDED	PART #	PART DESCRIPTION	QTY
TOP	VARIES	TOP, (STYLE VARIES), 1.00X30X60,BLK, (EITHER FIXTURE OR FLAT)	1
CABINET	N/A	B98 OR B97 - 18"W X 35"H X 26.25"D	1
CABINET	N/A	B26 - 18"W X 35"H X 26.25"D	1
BACK PANEL	N/A	58"W X 35"H X 0.75"D	1
APRON	N/A	0.81"THK X 4.50"W X 22"L	1
SCREWS - BACK PANEL	100478	SCREW,#8X1 ¼ SQ. WASHER FLAT HEAD	12
L BRACKET	100355	BRACKET, RAIL 1.25X1.25X4.25	2
SCREWS - L BRACKET	100649	SCREW,#8X¾ PHIL TRUSS HEAD SMS	8
SILICONE	100711	SILICONE,SEALANT,CLEAR	1
RUBBER BASE MOLDING	100283	RUBBER BASE MOLDING (SOLD BY FOOT)	19
STAINLESS STEEL CORNERS	100057	CORNER-STAINLESS STEEL, BASE	8
SCREWS - BASE	100064	SCREW,#6X½ PTH SMS SS SCREW	32
ELECTRICAL BOX	100033	ELECTRICAL BOX 3.00X2X2.5 DEEP	1
ELECTRICAL OUTLET	100034	ELEC,OUTLET,GFI,20A 125V, BLK	1
FIXTURE - FAUCET	100074-BKR	FIXTURE,L65-WSA-DIV (MULTI-SERVICE)	1
FIXTURE - SINK	100692	SINK,EPOXY L5C,BLK	1
FIXTURE - SINK TRAP	100056	SINK TRAP,PLASTIC ADJUSTABLE	1
FIXTURE - SINK OUTLET/STRAINER	254047	SINK OUTLET TAIL PIECE/INTEGRAL STRAINER,BLK	1

NOTE:

- TOPS ARE EITHER PHENOLIC OR EPOXY.
- **XX** INDICATES ITEMS USED ONLY FOR UNITS WITH A SINK OR FIXTURES.
- CABINETS VARY WITH STYLE OF INSTRUCTOR'S DESK PURCHASED.
 - EX. 1210-L OR 1210-R

REV.	DESCRIPTION	DATE	NAME	ECN NO.
C	UPDATED SILICONE PROCEDURE	8/16/23	RJM	-
A	CREATED DRAWING	11/9/16	EMR	-
REVISION LEVEL				

ALL DIMENSIONS ARE IN INCHES UNLESS NOTED OTHERWISE
 DECIMALS: .X = ± .030
 .XX = ± .020
 .XXX = ± .010
 ANGLES: = ± 1°
 CABINET SQUARENESS = ± .0625

DWN BY:	EMR	DATE DWN:	11/9/16
APR BY:		DATE APR:	
APR BY:		DATE APR:	

CONFIDENTIAL:
 ALL DESIGN RIGHTS RESERVED
 THE INFORMATION, DATA, DESIGN, AND DRAWINGS EMBODIED IN THIS DOCUMENT AND ALL REPRODUCTIONS THEREOF ARE THE EXCLUSIVE PROPERTY OF DIVERSIFIED WOODCRAFTS, INC.

THESE DOCUMENTS ARE SUPPLIED WITH THE UNDERSTANDING THAT THEY WILL NOT BE DISCLOSED TO THIRD PARTIES WITHOUT WRITTEN CONSENT OF DIVERSIFIED WOODCRAFTS, INC. ANY REPRODUCTION IN PART OR WHOLE WITHOUT WRITTEN CONSENT IS SUBJECT TO LEGAL ACTION.



300 South Krueger Street
 Suring, WI 54174
 diversifiedwoodcrafts.com

TITLE:
5' INSTRUCTOR DESK TOOLS AND ASSEMBLY COMPONENTS

DRAWING NUMBER:	SCALE:	SHEET:	REVISION:
1214 & 1214F, 1216 & 1216F	NTS	2 OF 14	REV C

ASSEMBLY COMPONENTS

ITEMS INCLUDED	PART #	PART DESCRIPTION	QTY
ROD SOCKET	206505	ROD SOCKET ASSY, SOCKET, WASHER, NUT	2
CROSSBAR	100005	ROD, CROSSBAR 3/4 DIA. X 18 L	1
UPRIGHT	100004	ROD, UPRIGHT 3/4 DIA. X 36 L	2
CLAMP	100002	ROD CLAMP 3/4 X 3/4 ASSY	2

NOTE:

1. TOPS ARE EITHER PHENOLIC OR EPOXY.
2. **XX** INDICATES ITEMS USED ONLY FOR UNITS WITH A SINK OR FIXTURES.
3. CABINETS VARY WITH STYLE OF INSTRUCTOR'S DESK PURCHASED.
 - 3.1. EX. 1210-L OR 1210-R

REV.	DESCRIPTION	DATE	NAME	ECN NO.
C	UPDATED SILICONE PROCEDURE	8/16/23	RJM	-
A	CREATED DRAWING	11/9/16	EMR	-
REVISION LEVEL				

<p>ALL DIMENSIONS ARE IN INCHES UNLESS NOTED OTHERWISE DECIMALS: .X = ± .030 .XX = ± .020 .XXX = ± .010 ANGLES: = ± 1° CABINET SQUARENESS = ± .0625</p>	<p>DWN BY: EMR APR BY: APR BY:</p>	<p>DATE DWN: 11/9/16 DATE APR: DATE APR:</p>
<p>CONFIDENTIAL: ALL DESIGN RIGHTS RESERVED. THE INFORMATION, DATA, DESIGN, AND DRAWINGS EMBODIED IN THIS DOCUMENT AND ALL REPRODUCTIONS THEREOF ARE THE EXCLUSIVE PROPERTY OF DIVERSIFIED WOODCRAFTS, INC.</p>		
<p>THESE DOCUMENTS ARE SUPPLIED WITH THE UNDERSTANDING THAT THEY WILL NOT BE DISCLOSED TO THIRD PARTIES WITHOUT WRITTEN CONSENT OF DIVERSIFIED WOODCRAFTS, INC. ANY REPRODUCTION IN PART OR WHOLE WITHOUT WRITTEN CONSENT IS SUBJECT TO LEGAL ACTION.</p>		

300 South Krueger Street
 Suring, WI 54174
 diversifiedwoodcrafts.com

TITLE:
5' INSTRUCTOR DESK TOOLS AND ASSEMBLY COMPONENTS

DRAWING NUMBER:	SCALE:	SHEET:	REVISION:
1214 & 1214F, 1216 & 1216F	NTS	3 OF 14	REV C

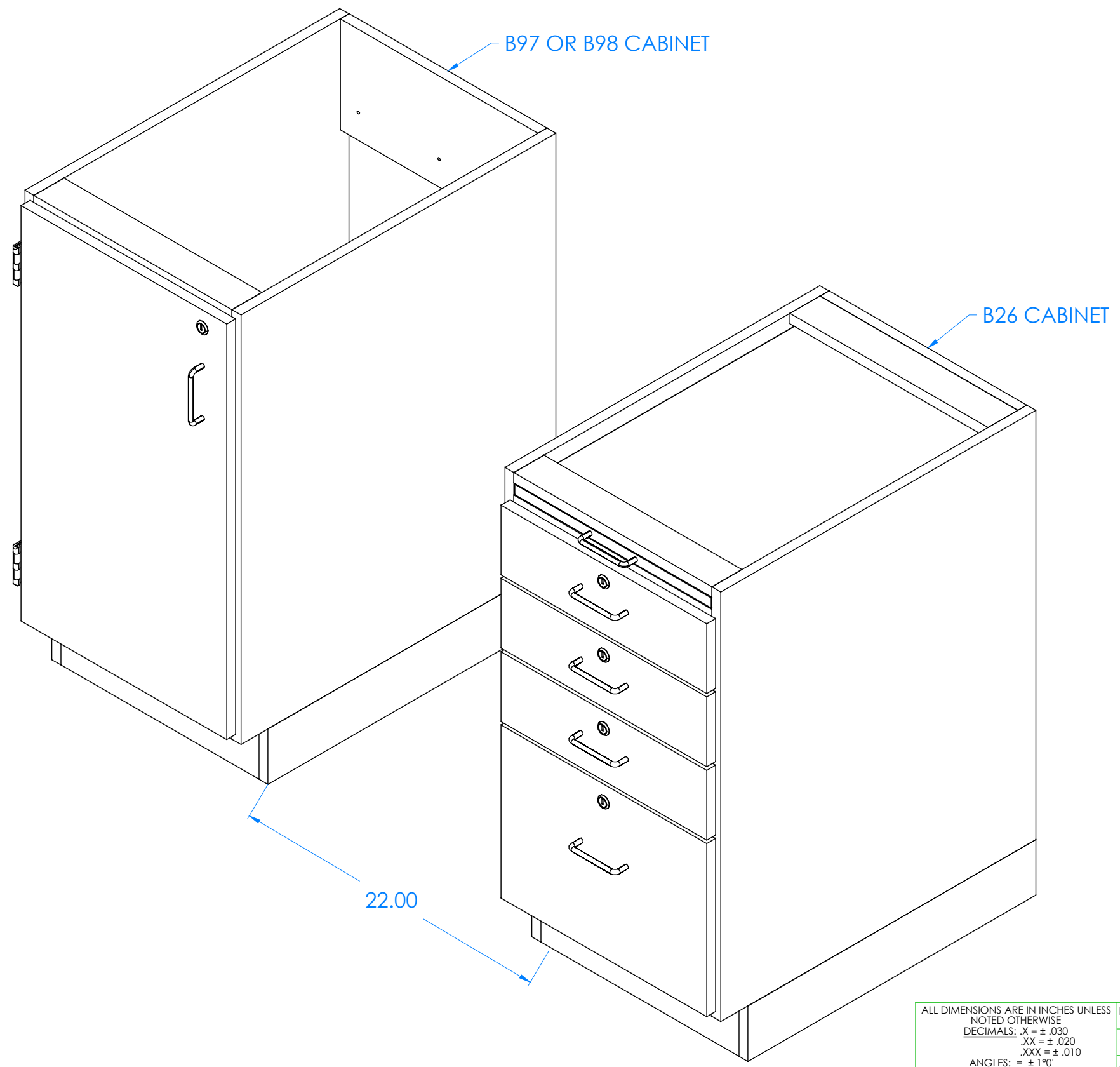

HARDWARE REQUIRED FOR STEP		
QTY	DESCRIPTION	PART NUMBER
1	CABINET	N/A
1	CABINET	N/A

STEP 1:

- a. POSITION THE TWO CABINETS IN DESIRED LOCATION.
- b. IF YOU HAVE A UNIT WITH A SINK OR FIXTURES, PLACE UNIT OVER UTILITY HOOKUPS.
- c. LEAVE ENOUGH ROOM IN BETWEEN CABINETS FOR APRON.
- d. LEVEL CABINETS.
- e. ATTACH TO FLOOR.

NOTE:
1.

REV.	DESCRIPTION	DATE	NAME	ECN NO.
C	UPDATED SILICONE PROCEDURE	8/16/23	RJM	-
A	CREATED DRAWING	11/9/16	EMR	-

REVISION LEVEL

ALL DIMENSIONS ARE IN INCHES UNLESS NOTED OTHERWISE DECIMALS: .X = ± .030 .XX = ± .020 .XXX = ± .010 ANGLES: = ± 1° CABINET SQUARENESS = ± .0625	DWN BY: EMR APR BY: APR BY:	DATE DWN: 11/9/16 DATE APR: DATE APR:
---	-----------------------------------	---

CONFIDENTIAL:
ALL DESIGN RIGHTS RESERVED.
THE INFORMATION, DATA, DESIGN, AND DRAWINGS EMBODIED IN THIS DOCUMENT AND ALL REPRODUCTIONS THEREOF ARE THE EXCLUSIVE PROPERTY OF DIVERSIFIED WOODCRAFTS, INC.

THESE DOCUMENTS ARE SUPPLIED WITH THE UNDERSTANDING THAT THEY WILL NOT BE DISCLOSED TO THIRD PARTIES WITHOUT WRITTEN CONSENT OF DIVERSIFIED WOODCRAFTS, INC. ANY REPRODUCTION IN PART OR WHOLE WITHOUT WRITTEN CONSENT IS SUBJECT TO LEGAL ACTION.



300 South Krueger Street
Suring, WI 54174
diversifiedwoodcrafts.com

TITLE:
**5' INSTRUCTOR DESK
ASSEMBLY INSTRUCTIONS**

DRAWING NUMBER: 1214 & 1214F, 1216 & 1216F	SCALE: NTS	SHEET: 4 OF 14	REVISION: REV C
--	---------------	-------------------	--------------------

HARDWARE REQUIRED FOR STEP		
QTY	DESCRIPTION	PART NUMBER
1	BACK PANEL	N/A
12	SCREWS - BACK PANEL	100478

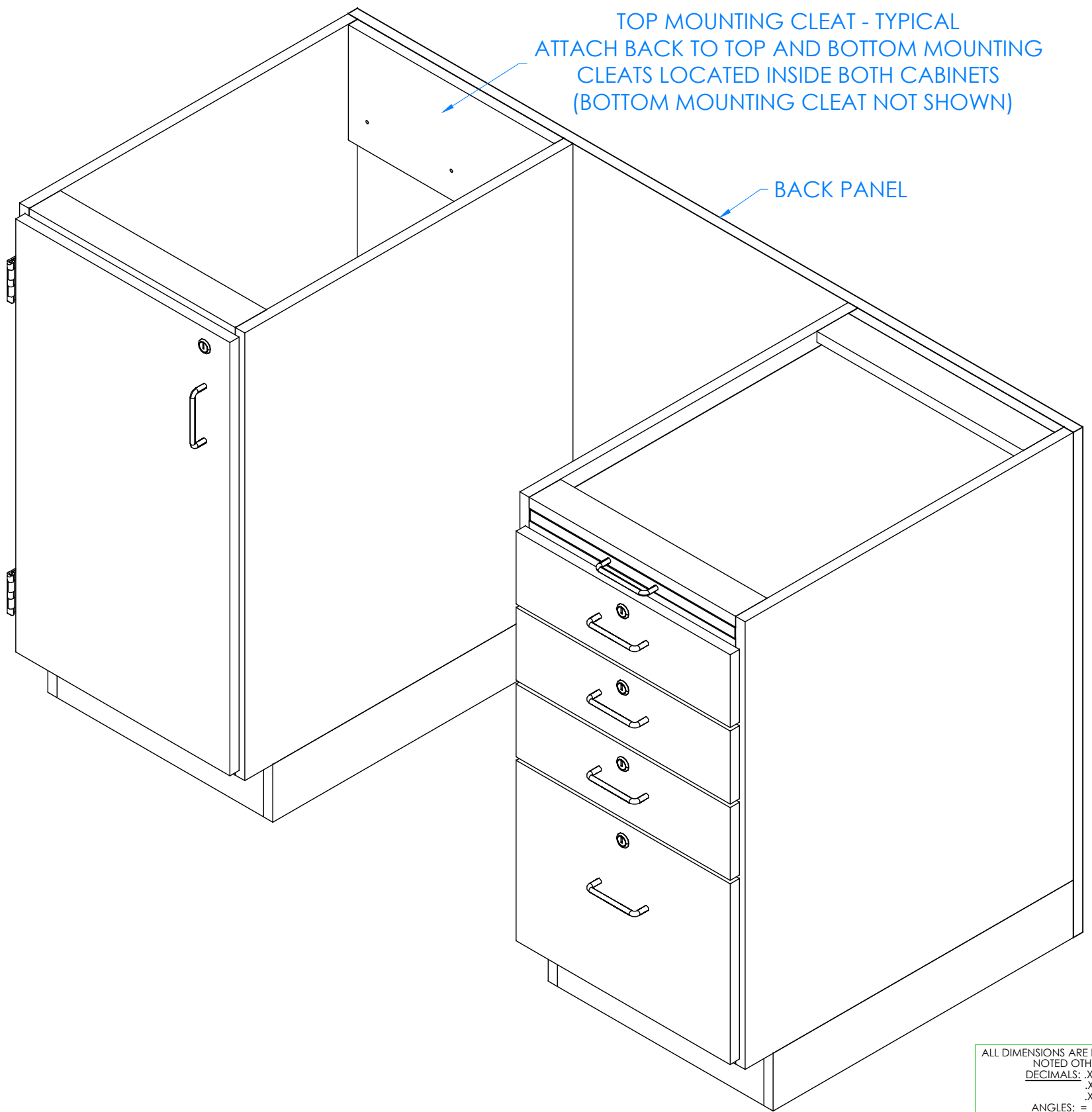

STEP 2:

- a. ATTACH BACK PANEL TO BACK OF CABINETS USING PROVIDED HARDWARE LISTED ABOVE.
- b. SCREW INTO TOP AND BOTTOM MOUNTING CLEATS LOCATED INSIDE BOTH CABINETS.
- c. MAKE SURE BACK PANEL IS FLUSH WITH OUTSIDE EDGES OF CABINETS.

NOTE:
1.

ALL DIMENSIONS ARE IN INCHES UNLESS NOTED OTHERWISE DECIMALS: .X = ± .030 .XX = ± .020 .XXX = ± .010 ANGLES: = ± 1° CABINET SQUARENESS = ± .0625	DWN BY: EMR APR BY: APR BY:	DATE DWN: 11/9/16 DATE APR: DATE APR:
---	-----------------------------------	---



300 South Krueger Street
Suring, WI 54174
diversifiedwoodcrafts.com

CONFIDENTIAL:
ALL DESIGN RIGHTS RESERVED.
THE INFORMATION, DATA, DESIGN, AND DRAWINGS EMBODIED IN THIS DOCUMENT AND ALL REPRODUCTIONS THEREOF ARE THE EXCLUSIVE PROPERTY OF DIVERSIFIED WOODCRAFTS, INC.

TITLE:
**5' INSTRUCTOR DESK
ASSEMBLY INSTRUCTIONS**

REV.	DESCRIPTION	DATE	NAME	ECN NO.
C	UPDATED SILICONE PROCEDURE	8/16/23	RJM	-
A	CREATED DRAWING	11/9/16	EMR	-

REVISION LEVEL

THESE DOCUMENTS ARE SUPPLIED WITH THE UNDERSTANDING THAT THEY WILL NOT BE DISCLOSED TO THIRD PARTIES WITHOUT WRITTEN CONSENT OF DIVERSIFIED WOODCRAFTS, INC. ANY REPRODUCTION IN PART OR WHOLE WITHOUT WRITTEN CONSENT IS SUBJECT TO LEGAL ACTION.

DRAWING NUMBER:	SCALE:	SHEET:	REVISION:
1214 & 1214F, 1216 & 1216F	NTS	5 OF 14	REV C

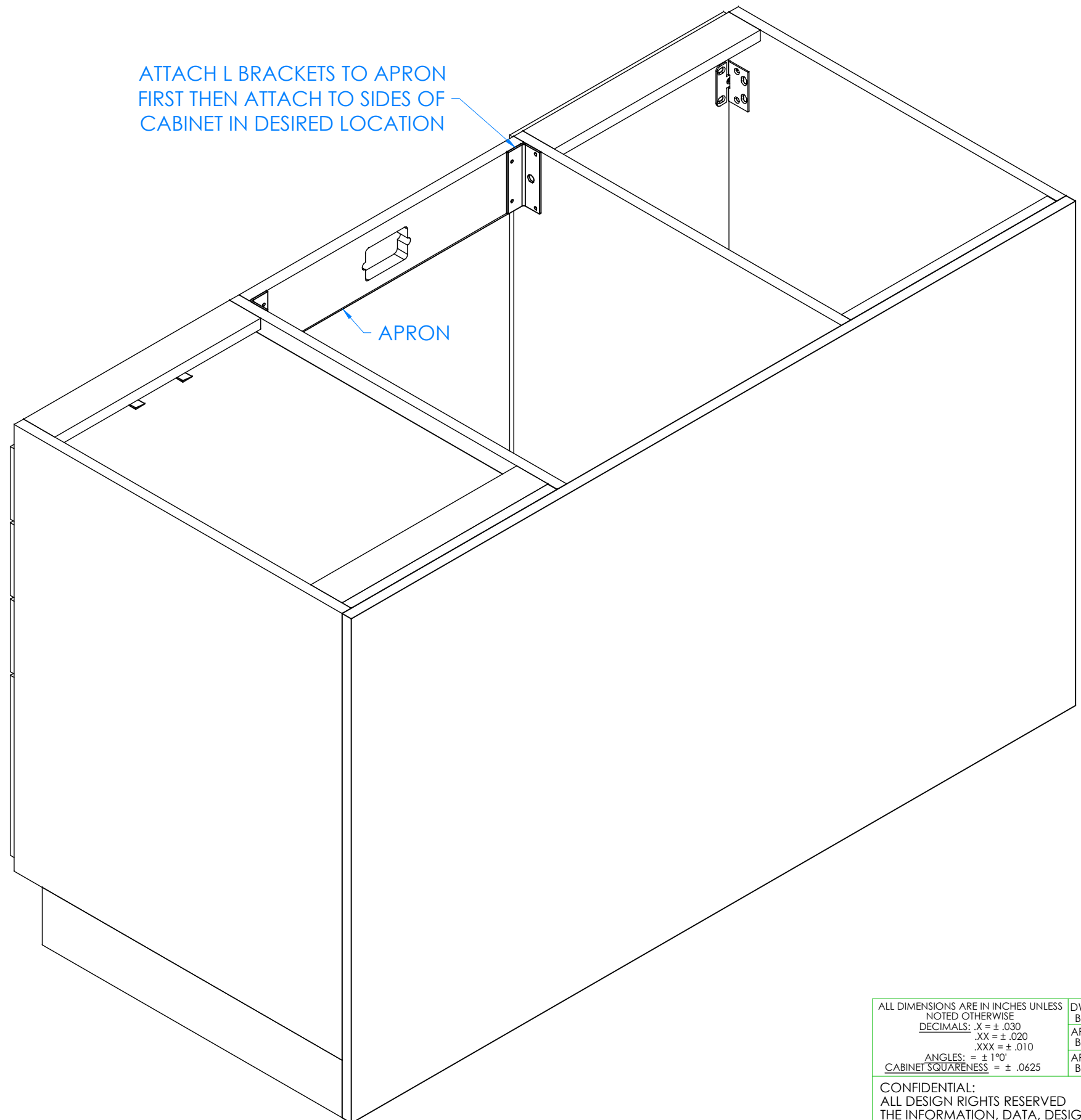

HARDWARE REQUIRED FOR STEP

QTY	DESCRIPTION	PART NUMBER
1	APRON	N/A
2	L BRACKET	100355
8	SCREWS - L BRACKET	100649
1	ELECTRICAL BOX	100033
1	ELECTRICAL OUTLET	100034

STEP 3:

- a. ATTACH L BRACKETS TO APRON WITH PROVIDED HARDWARE LISTED ABOVE.
- b. MAKE SURE BRACKETS ARE FLUSH WITH TOP EDGE OF APRON.
- c. MOUNT APRON TO SIDES OF BOTH CABINETS IN DESIRED LOCATION WITH REMAINING SCREWS.

NOTE:
1.

BACK SIDE OF INSTRUCTOR'S DESK

REV.	DESCRIPTION	DATE	NAME	ECN NO.
C	UPDATED SILICONE PROCEDURE	8/16/23	RJM	-
A	CREATED DRAWING	11/9/16	EMR	-

REVISION LEVEL

ALL DIMENSIONS ARE IN INCHES UNLESS NOTED OTHERWISE
 DECIMALS: .X = ± .030
 .XX = ± .020
 .XXX = ± .010
 ANGLES: = ± 1°
 CABINET SQUARENESS = ± .0625

DWN BY:	EMR	DATE DWN:	11/9/16
APR BY:		DATE APR:	
APR BY:		DATE APR:	

CONFIDENTIAL:
 ALL DESIGN RIGHTS RESERVED.
 THE INFORMATION, DATA, DESIGN, AND DRAWINGS EMBODIED IN THIS DOCUMENT AND ALL REPRODUCTIONS THEREOF ARE THE EXCLUSIVE PROPERTY OF DIVERSIFIED WOODCRAFTS, INC.

THESE DOCUMENTS ARE SUPPLIED WITH THE UNDERSTANDING THAT THEY WILL NOT BE DISCLOSED TO THIRD PARTIES WITHOUT WRITTEN CONSENT OF DIVERSIFIED WOODCRAFTS, INC. ANY REPRODUCTION IN PART OR WHOLE WITHOUT WRITTEN CONSENT IS SUBJECT TO LEGAL ACTION.



300 South Krueger Street
 Suring, WI 54174
 diversifiedwoodcrafts.com

TITLE:
5' INSTRUCTOR DESK ASSEMBLY INSTRUCTIONS

DRAWING NUMBER:	SCALE:	SHEET:	REVISION:
1214 & 1214F, 1216 & 1216F	NTS	6 OF 14	REV C

STEP 4:

- a. APPLY SILICONE ADHESIVE TO TOP EDGES OF CABINETS AND APRON.
- b. APPLY SILICONE ADHESIVE IN DOT PATTERN LIKE SHOWN BELOW FOR BEST RESULTS.
- c. PLACE TOP ON UNIT WITH PROPER OVERHANG (1" OVERHANG ON SIDES AND 1.50" ON FRONT AND BACK).
- d. CLAMP ON TOP TO TOP RAILS OF CABINETS AND APRON TO REMOVE ANY WARP USING SHIMS AND C-CLAMPS, IF NEEDED, WHEN ALIGNING THE TOP (DO THIS BEFORE ADHESIVE ON EDGES SETS UP).
- e. LET CURE FOR 6-12 HOURS.

HARDWARE REQUIRED FOR STEP

QTY	DESCRIPTION	PART NUMBER
1	TOP	VARIABLES
1	SILICONE	100711

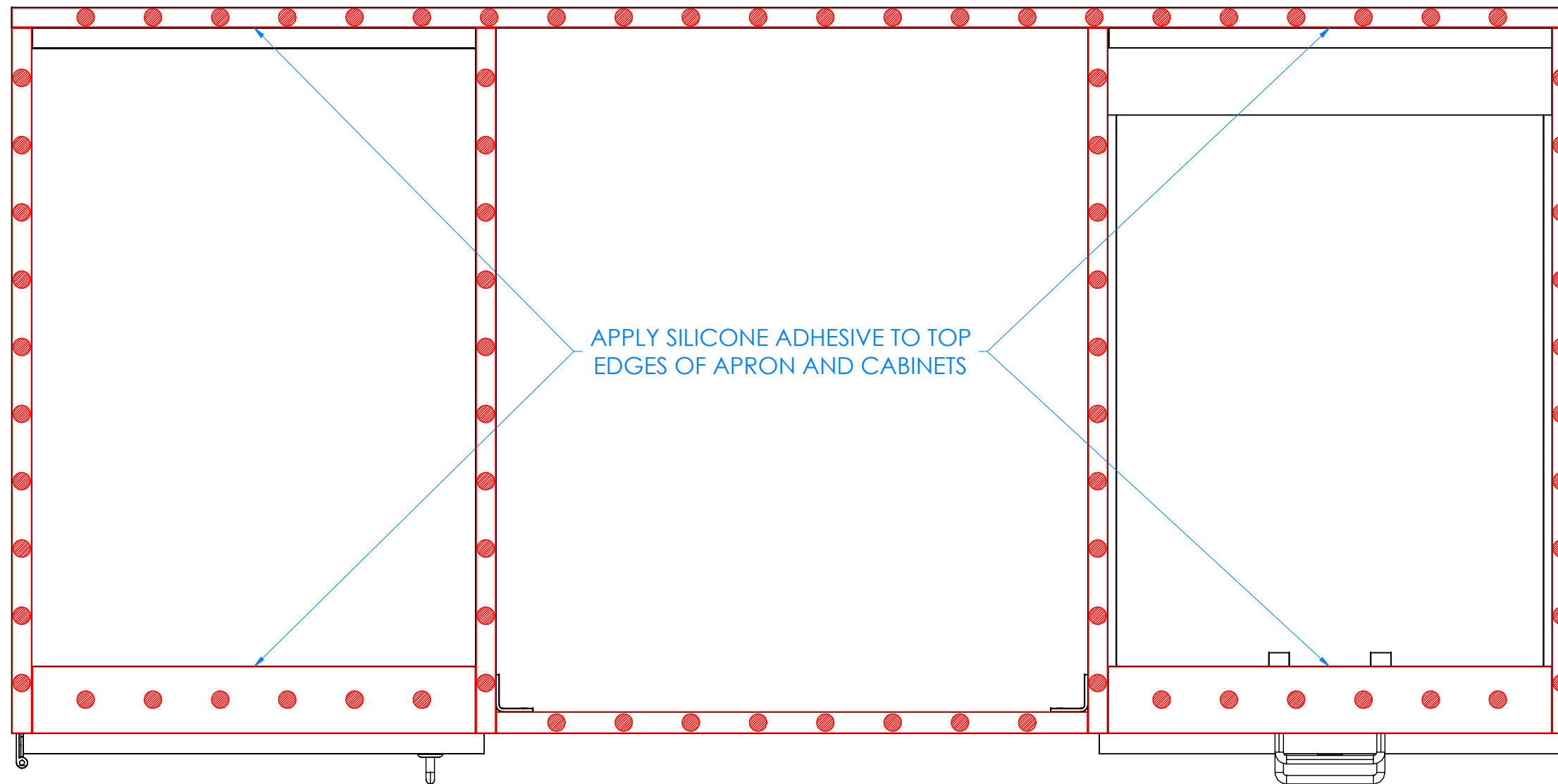

TOP VIEW OF INSTRUCTOR'S DESK SHOWN

NOTE:

1.

ALL DIMENSIONS ARE IN INCHES UNLESS NOTED OTHERWISE DECIMALS: .X = ± .030 .XX = ± .020 .XXX = ± .010 ANGLES: = ± 1° CABINET SQUARENESS = ± .0625	DWN BY:	EMR	DATE DWN:	11/9/16
	APR BY:		DATE APR:	
	BY:		DATE APR:	
	BY:		DATE APR:	



300 South Krueger Street
 Suring, WI 54174
 diversifiedwoodcrafts.com

CONFIDENTIAL:
 ALL DESIGN RIGHTS RESERVED.
 THE INFORMATION, DATA, DESIGN, AND DRAWINGS EMBODIED IN THIS DOCUMENT AND ALL REPRODUCTIONS THEREOF ARE THE EXCLUSIVE PROPERTY OF DIVERSIFIED WOODCRAFTS, INC.

TITLE:
5' INSTRUCTOR DESK ASSEMBLY INSTRUCTIONS

THESE DOCUMENTS ARE SUPPLIED WITH THE UNDERSTANDING THAT THEY WILL NOT BE DISCLOSED TO THIRD PARTIES WITHOUT WRITTEN CONSENT OF DIVERSIFIED WOODCRAFTS, INC. ANY REPRODUCTION IN PART OR WHOLE WITHOUT WRITTEN CONSENT IS SUBJECT TO LEGAL ACTION.

REV.	DESCRIPTION	DATE	NAME	ECN NO.
C	UPDATED SILICONE PROCEDURE	8/16/23	RJM	-
A	CREATED DRAWING	11/9/16	EMR	-

REVISION LEVEL

DRAWING NUMBER:	SCALE:	SHEET:	REVISION:
1214 & 1214F, 1216 & 1216F	NTS	7 OF 14	REV C

STEP 5:

- a. IF YOU DON'T HAVE A UNIT WITH A SINK, SKIP TO STEP 6.
- b. APPLY SILICONE ADHESIVE TO SINK OPENING ON TOP.
- c. LOWER SINK INTO OPENING.
- d. WIPE OFF ANY EXCESS CAULK AND ALLOW TO SET.
- e. LET CURE FOR 6-12 HOURS.

HARDWARE REQUIRED FOR STEP

QTY	DESCRIPTION	PART NUMBER
1	FIXTURE - SINK	100692
1	SILICONE	100711

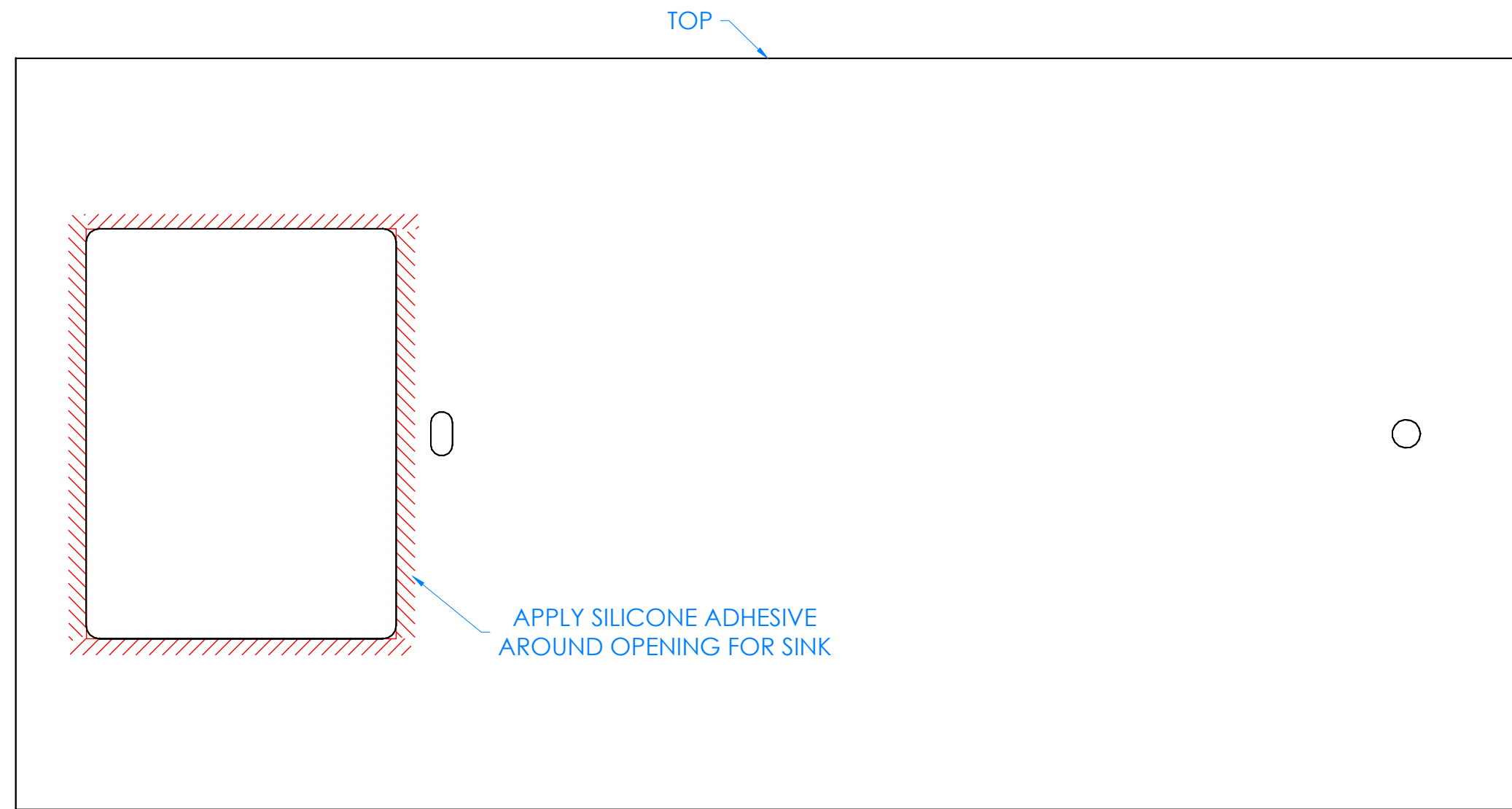

TOP VIEW OF INSTRUCTOR'S DESK SHOWN

NOTE:

1.

ALL DIMENSIONS ARE IN INCHES UNLESS NOTED OTHERWISE DECIMALS: .X = ± .030 .XX = ± .020 .XXX = ± .010 ANGLES: = ± 1° CABINET SQUARENESS = ± .0625	DWN BY:	EMR	DATE DWN:	11/9/16
	APR BY:		DATE APR:	
	APR BY:		DATE APR:	
	APR BY:		DATE APR:	



300 South Krueger Street
 Suring, WI 54174
 diversifiedwoodcrafts.com

CONFIDENTIAL:
 ALL DESIGN RIGHTS RESERVED.
 THE INFORMATION, DATA, DESIGN, AND DRAWINGS EMBODIED IN THIS DOCUMENT AND ALL REPRODUCTIONS THEREOF ARE THE EXCLUSIVE PROPERTY OF DIVERSIFIED WOODCRAFTS, INC.

TITLE:
5' INSTRUCTOR DESK ASSEMBLY INSTRUCTIONS

THESE DOCUMENTS ARE SUPPLIED WITH THE UNDERSTANDING THAT THEY WILL NOT BE DISCLOSED TO THIRD PARTIES WITHOUT WRITTEN CONSENT OF DIVERSIFIED WOODCRAFTS, INC. ANY REPRODUCTION IN PART OR WHOLE WITHOUT WRITTEN CONSENT IS SUBJECT TO LEGAL ACTION.

REV.	DESCRIPTION	DATE	NAME	ECN NO.
C	UPDATED SILICONE PROCEDURE	8/16/23	RJM	-
A	CREATED DRAWING	11/9/16	EMR	-
REVISION LEVEL				

DRAWING NUMBER:	SCALE:	SHEET:	REVISION:
1214 & 1214F, 1216 & 1216F	NTS	8 OF 14	REV C

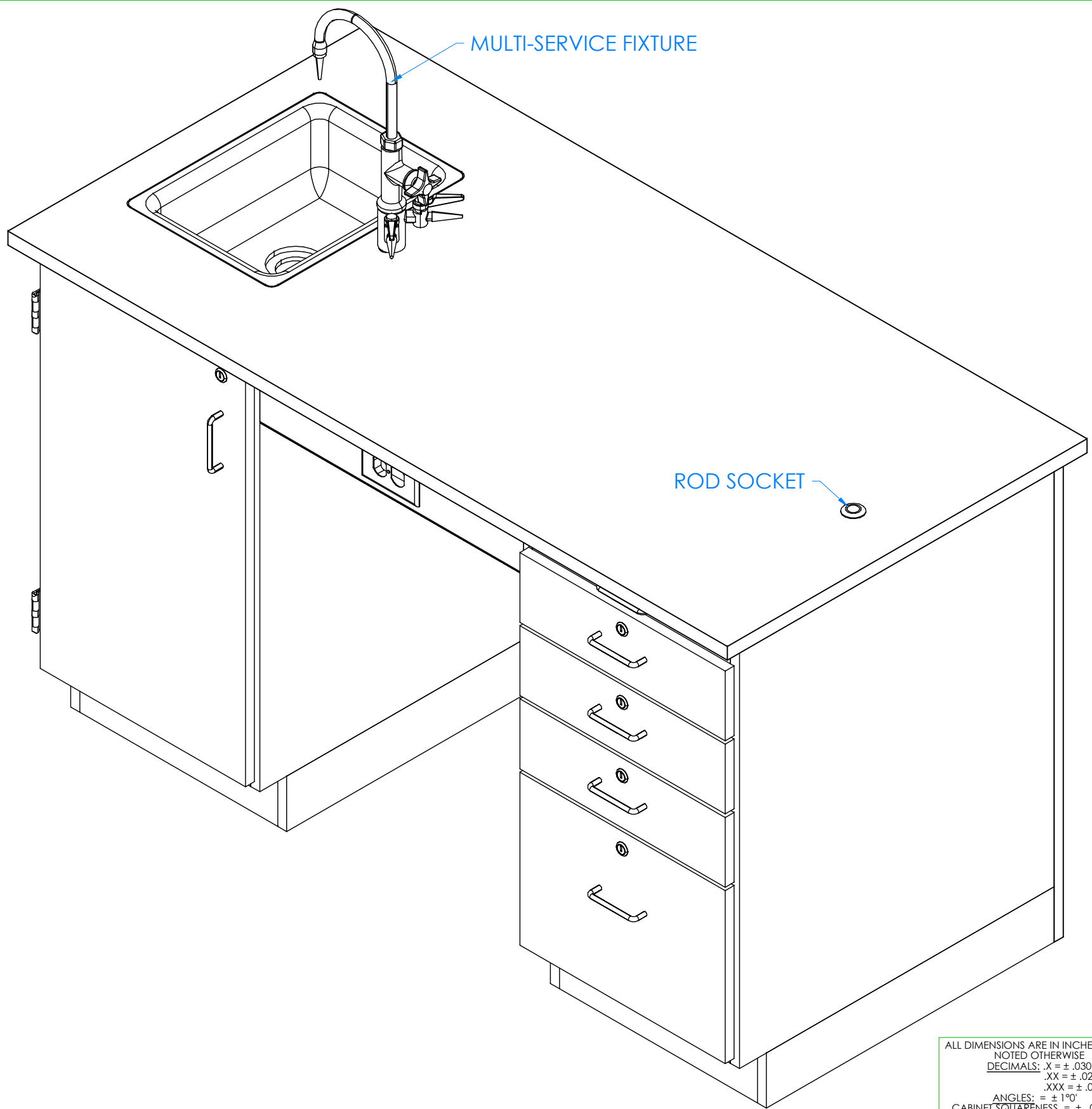

HARDWARE REQUIRED FOR STEP		
QTY	DESCRIPTION	PART NUMBER
1	FIXTURE - FAUCET	100074-BKR
1	FIXTURE - SINK TRAP	100056
1	FIXTURE - SINK OUTLET/STRAINER	254047
2	ROD SOCKET	206505

STEP 6:

- a. IF YOU DON'T HAVE A UNIT WITH FIXTURES, SKIP TO STEP 10.
- b. INSTALL MULTI-SERVICE FIXTURE IN THE HOLE PROVIDED ON TOP.
- c. INSTALL SINK TRAP AND SINK OUTLET/STRAINER INTO SINK.
- d. INSERT ROD SOCKET INTO PRE-DRILLED HOLE IN TOP.

NOTE:

- 1. ALL WATER, ELECTRICAL, AND GAS CONNECTIONS SHOULD BE PERFORMED BY A TRAINED PROFESSIONAL PER LOCAL CODE.

REV.	DESCRIPTION	DATE	NAME	ECN NO.
C	UPDATED SILICONE PROCEDURE	8/16/23	RJM	-
A	CREATED DRAWING	11/9/16	EMR	-

REVISION LEVEL

ALL DIMENSIONS ARE IN INCHES UNLESS NOTED OTHERWISE
 DECIMALS: .X = ± .030
 .XX = ± .020
 .XXX = ± .010
 ANGLES: = ± 1°
 CABINET SQUARENESS = ± .0625

DWN BY:	EMR	DATE DWN:	11/9/16
APR BY:		DATE APR:	
APR BY:		DATE APR:	

CONFIDENTIAL:
 ALL DESIGN RIGHTS RESERVED.
 THE INFORMATION, DATA, DESIGN, AND DRAWINGS EMBODIED IN THIS DOCUMENT AND ALL REPRODUCTIONS THEREOF ARE THE EXCLUSIVE PROPERTY OF DIVERSIFIED WOODCRAFTS, INC.

THESE DOCUMENTS ARE SUPPLIED WITH THE UNDERSTANDING THAT THEY WILL NOT BE DISCLOSED TO THIRD PARTIES WITHOUT WRITTEN CONSENT OF DIVERSIFIED WOODCRAFTS, INC. ANY REPRODUCTION IN PART OR WHOLE WITHOUT WRITTEN CONSENT IS SUBJECT TO LEGAL ACTION.



300 South Krueger Street
 Suring, WI 54174
 diversifiedwoodcrafts.com

TITLE:
**5' INSTRUCTOR DESK
 ASSEMBLY INSTRUCTIONS**

DRAWING NUMBER:	SCALE:	SHEET:	REVISION:
1214 & 1214F, 1216 & 1216F	NTS	9 OF 14	REV C

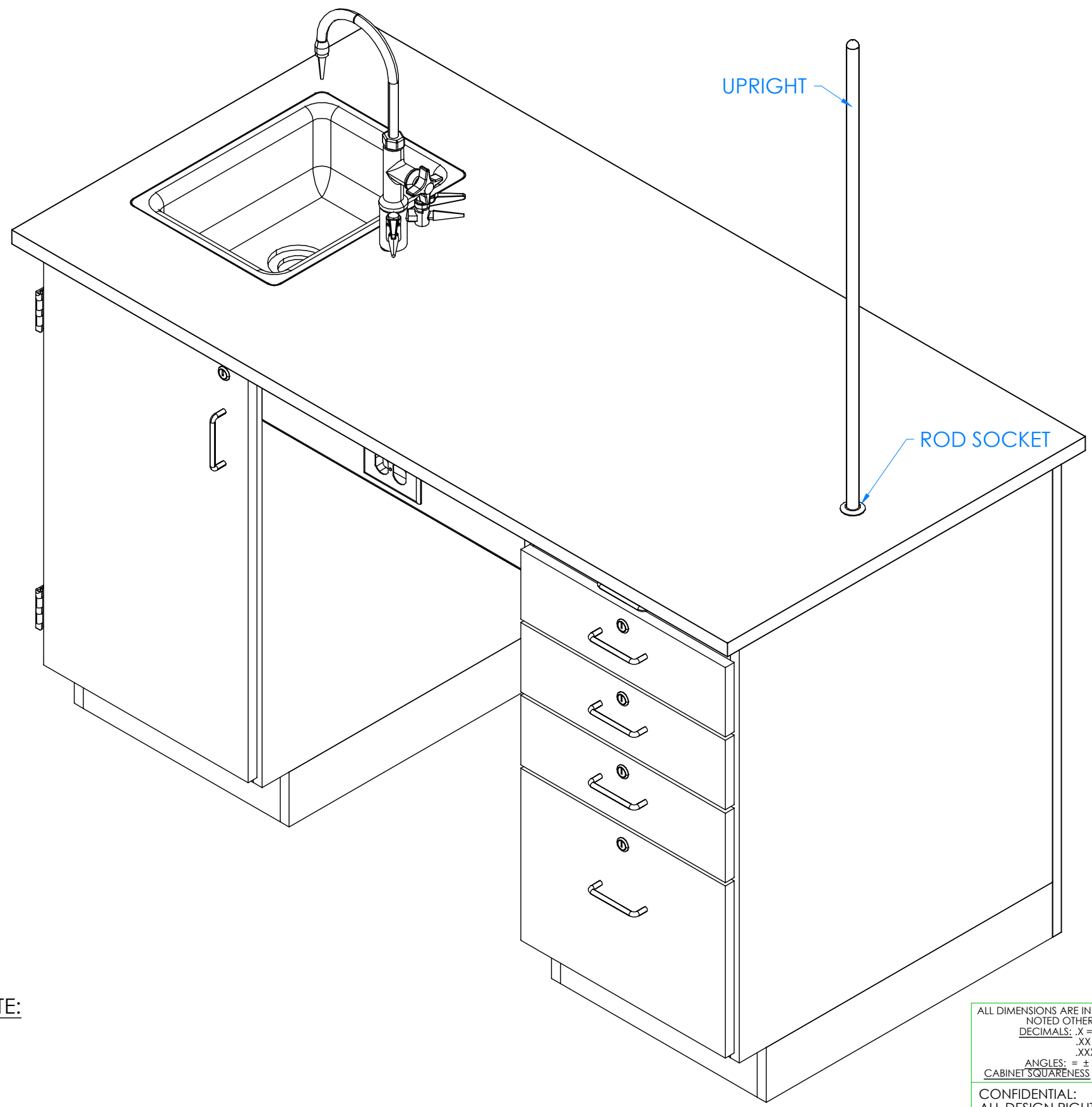

HARDWARE REQUIRED FOR STEP

QTY	DESCRIPTION	PART NUMBER
2	UPRIGHT	100004

STEP 7:

- a. INSERT TAPERED END OF UPRIGHT INTO ROD SOCKET ON THE TOP.

NOTE:
1.

ALL DIMENSIONS ARE IN INCHES UNLESS NOTED OTHERWISE DECIMALS: .X = ± .030 .XX = ± .020 .XXX = ± .010 ANGLES: = ± 1° CABINET SQUARENESS = ± .0625	DWN BY: EMR APR BY: APR BY:	DATE DWN: 11/9/16 DATE APR: DATE APR:
---	-----------------------------------	---

300 South Krueger Street
Suring, WI 54174
diversifiedwoodcrafts.com

CONFIDENTIAL:
ALL DESIGN RIGHTS RESERVED
THE INFORMATION, DATA, DESIGN, AND DRAWINGS EMBODIED IN THIS DOCUMENT AND ALL REPRODUCTIONS THEREOF ARE THE EXCLUSIVE PROPERTY OF DIVERSIFIED WOODCRAFTS, INC.

TITLE:
**5' INSTRUCTOR DESK
ASSEMBLY INSTRUCTIONS**

REV.	DESCRIPTION	DATE	NAME	ECN NO.
C	UPDATED SILICONE PROCEDURE	8/16/23	RJM	-
A	CREATED DRAWING	11/9/16	EMR	-

REVISION LEVEL

THESE DOCUMENTS ARE SUPPLIED WITH THE UNDERSTANDING THAT THEY WILL NOT BE DISCLOSED TO THIRD PARTIES WITHOUT WRITTEN CONSENT OF DIVERSIFIED WOODCRAFTS, INC. ANY REPRODUCTION IN PART OR WHOLE WITHOUT WRITTEN CONSENT IS SUBJECT TO LEGAL ACTION.

DRAWING NUMBER: 1214 & 1214F, 1216 & 1216F	SCALE: NTS	SHEET: 10 OF 14	REVISION: REV C
--	---------------	--------------------	--------------------

HARDWARE REQUIRED FOR STEP

QTY	DESCRIPTION	PART NUMBER
2	CLAMP	100002

STEP 8:

- a. SLIDE ROD CLAMP OVER UPRIGHT AND TIGHTEN IN DESIRED LOCATION USING THUMB SCREW PROVIDED ON CLAMP.

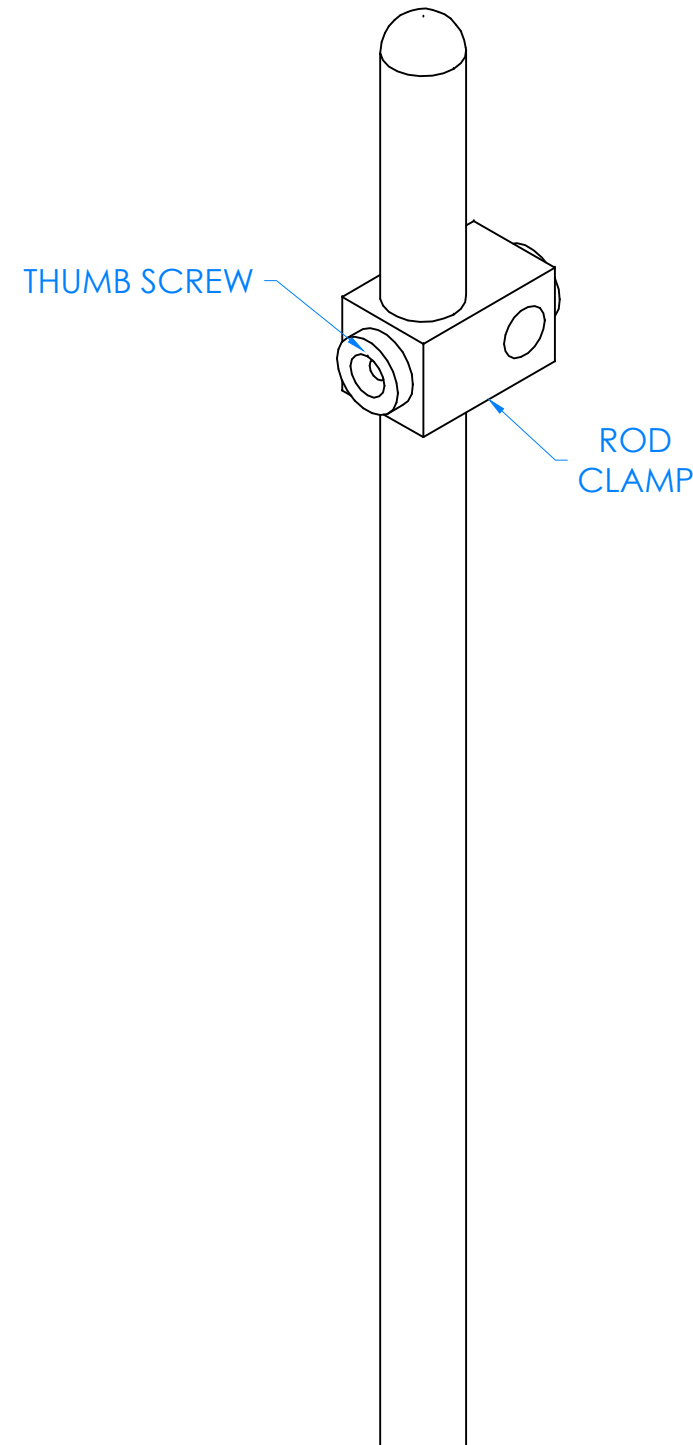

CLOSE UP OF UPRIGHT

NOTE:

1.

ALL DIMENSIONS ARE IN INCHES UNLESS NOTED OTHERWISE DECIMALS: .X = ± .030 .XX = ± .020 .XXX = ± .010 ANGLES: = ± 1° CABINET SQUARENESS = ± .0625	DWN BY:	EMR	DATE DWN:	11/9/16
	APR BY:		DATE APR:	
	APR BY:		DATE APR:	
	APR BY:		DATE APR:	



300 South Krueger Street
Suring, WI 54174
diversifiedwoodcrafts.com

CONFIDENTIAL:
ALL DESIGN RIGHTS RESERVED.
THE INFORMATION, DATA, DESIGN, AND DRAWINGS EMBODIED IN THIS DOCUMENT AND ALL REPRODUCTIONS THEREOF ARE THE EXCLUSIVE PROPERTY OF DIVERSIFIED WOODCRAFTS, INC.

TITLE:
5' INSTRUCTOR DESK ASSEMBLY INSTRUCTIONS

THESE DOCUMENTS ARE SUPPLIED WITH THE UNDERSTANDING THAT THEY WILL NOT BE DISCLOSED TO THIRD PARTIES WITHOUT WRITTEN CONSENT OF DIVERSIFIED WOODCRAFTS, INC. ANY REPRODUCTION IN PART OR WHOLE WITHOUT WRITTEN CONSENT IS SUBJECT TO LEGAL ACTION.

DRAWING NUMBER:	SCALE:	SHEET:	REVISION:
1214 & 1214F, 1216 & 1216F	NTS	11 OF 14	REV C

REV.	DESCRIPTION	DATE	NAME	ECN NO.
C	UPDATED SILICONE PROCEDURE	8/16/23	RJM	-
A	CREATED DRAWING	11/9/16	EMR	-
REVISION LEVEL				

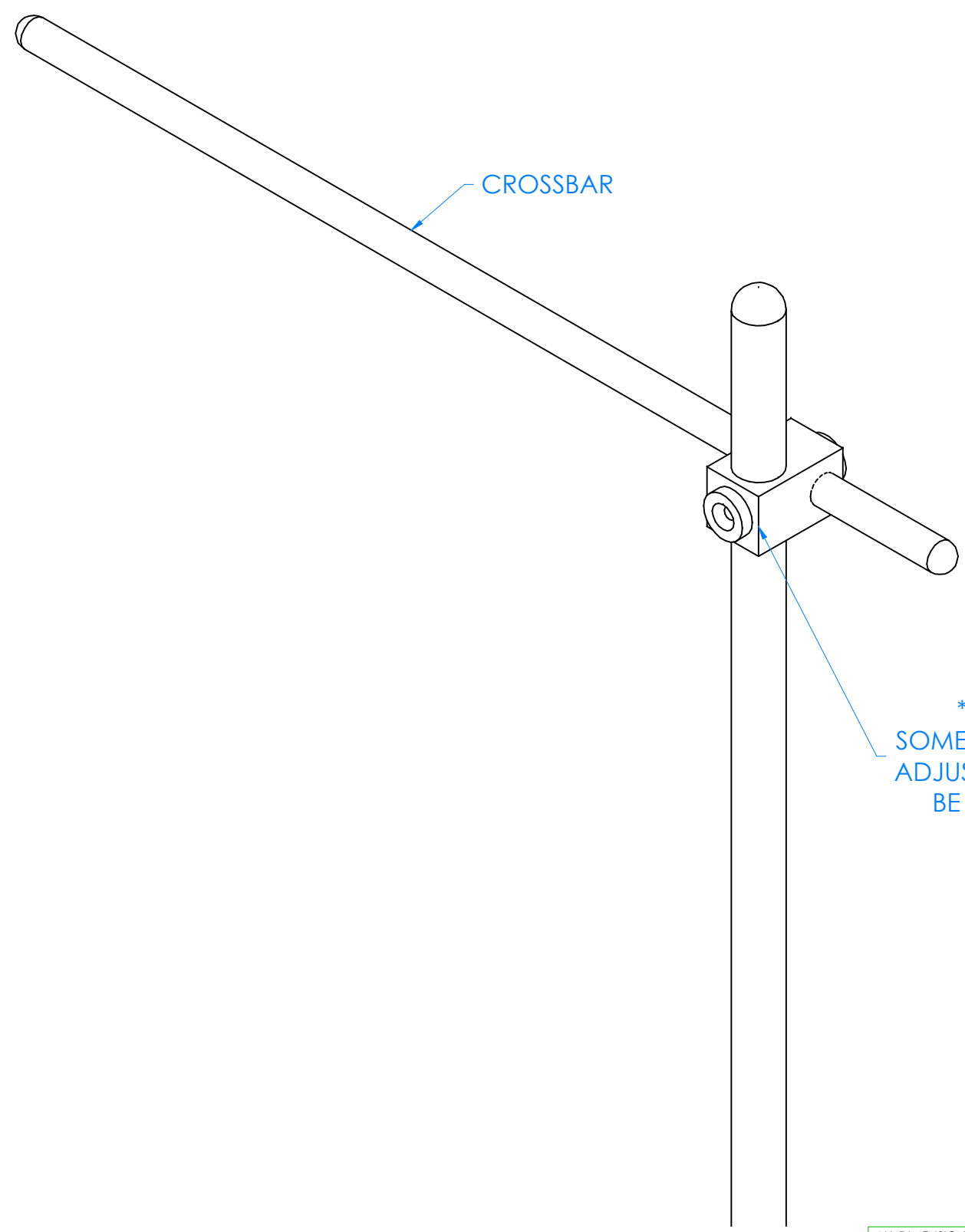

HARDWARE REQUIRED FOR STEP		
QTY	DESCRIPTION	PART NUMBER
1	CROSSBAR	100005

STEP 9:

- a. SLIDE CROSSBAR THROUGH THE CLAMP.

NOTE:

1.

CLOSE UP OF UPRIGHT AND CROSSBAR ASSEMBLY

ALL DIMENSIONS ARE IN INCHES UNLESS NOTED OTHERWISE DECIMALS: .X = ± .030 .XX = ± .020 .XXX = ± .010 ANGLES: = ± 1° CABINET SQUARENESS = ± .0625	DWN BY: EMR APR BY: APR BY:	DATE DWN: 11/9/16 DATE APR: DATE APR:
---	-----------------------------------	---



300 South Krueger Street
Suring, WI 54174
diversifiedwoodcrafts.com

CONFIDENTIAL:
ALL DESIGN RIGHTS RESERVED.
THE INFORMATION, DATA, DESIGN, AND DRAWINGS EMBODIED IN THIS DOCUMENT AND ALL REPRODUCTIONS THEREOF ARE THE EXCLUSIVE PROPERTY OF DIVERSIFIED WOODCRAFTS, INC.

TITLE:
5' INSTRUCTOR DESK ASSEMBLY INSTRUCTIONS

THESE DOCUMENTS ARE SUPPLIED WITH THE UNDERSTANDING THAT THEY WILL NOT BE DISCLOSED TO THIRD PARTIES WITHOUT WRITTEN CONSENT OF DIVERSIFIED WOODCRAFTS, INC. ANY REPRODUCTION IN PART OR WHOLE WITHOUT WRITTEN CONSENT IS SUBJECT TO LEGAL ACTION.

DRAWING NUMBER:	SCALE:	SHEET:	REVISION:
1214 & 1214F, 1216 & 1216F	NTS	12 OF 14	REV C

REV.	DESCRIPTION	DATE	NAME	ECN NO.
C	UPDATED SILICONE PROCEDURE	8/16/23	RJM	-
A	CREATED DRAWING	11/9/16	EMR	-
REVISION LEVEL				

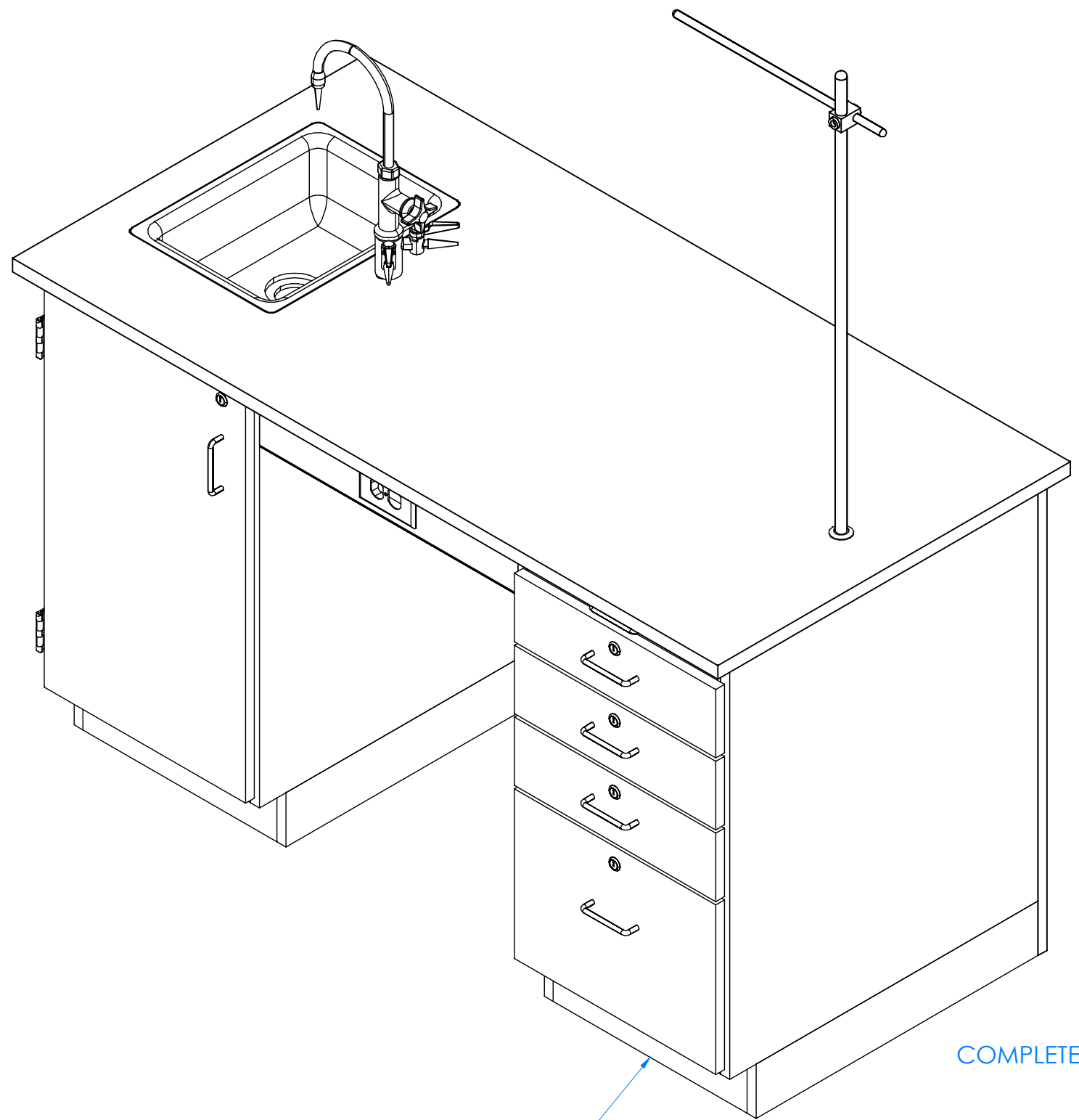

HARDWARE REQUIRED FOR STEP

QTY	DESCRIPTION	PART NUMBER
19	RUBBER BASE MOLDING	100283
8	STAINLESS STEEL CORNERS	100057
32	SCREWS - BASE	100064

STEP 10:

- a. ATTACH RUBBER MOLDING TO BASE OF INSTRUCTOR'S DESK USING CONTACT CEMENT.
- b. SCREW STAINLESS STEEL CORNER BRACKETS ON EACH CORNER OVER BASE MOLDING USING HARDWARE LISTED ABOVE.

NOTE:

1.

ATTACH RUBBER MOLDING TO BASE

COMPLETE UNIT SHOWN

ALL DIMENSIONS ARE IN INCHES UNLESS NOTED OTHERWISE DECIMALS: .X = ± .030 .XX = ± .020 .XXX = ± .010 ANGLES: = ± 1° CABINET SQUARENESS = ± .0625	DWN BY: EMR APR BY: APR BY:	DATE DWN: 11/9/16 DATE APR: DATE APR:
---	-----------------------------------	---



300 South Krueger Street
Suring, WI 54174
diversifiedwoodcrafts.com

CONFIDENTIAL:
ALL DESIGN RIGHTS RESERVED.
THE INFORMATION, DATA, DESIGN, AND DRAWINGS EMBODIED IN THIS DOCUMENT AND ALL REPRODUCTIONS THEREOF ARE THE EXCLUSIVE PROPERTY OF DIVERSIFIED WOODCRAFTS, INC.

TITLE:
5' INSTRUCTOR DESK
ASSEMBLY INSTRUCTIONS

THESE DOCUMENTS ARE SUPPLIED WITH THE UNDERSTANDING THAT THEY WILL NOT BE DISCLOSED TO THIRD PARTIES WITHOUT WRITTEN CONSENT OF DIVERSIFIED WOODCRAFTS, INC. ANY REPRODUCTION IN PART OR WHOLE WITHOUT WRITTEN CONSENT IS SUBJECT TO LEGAL ACTION.

DRAWING NUMBER:	SCALE:	SHEET:	REVISION:
1214 & 1214F, 1216 & 1216F	NTS	13 OF 14	REV C

REV.	DESCRIPTION	DATE	NAME	ECN NO.
C	UPDATED SILICONE PROCEDURE	8/16/23	RJM	-
A	CREATED DRAWING	11/9/16	EMR	-
REVISION LEVEL				

TROUBLESHOOTING YOUR GFCI ELECTRICAL RECEPTACLE:

PLEASE NOTE: THROUGHOUT ANY OF THE FOLLOWING STEPS (PROCEDURES); IF YOU ARE NOT SURE YOU CAN DO THIS JOB SAFELY, AND COMPETENTLY, REFER THIS WORK TO QUALIFIED PROFESSIONAL!

If your unit comes equipped with a GFCI (Ground Fault Circuit Interrupter) electrical receptacle, and there is no power in the receptacle please consider/check the following:

- The extension cord (if being used) is working properly.
- The breaker hasn't been tripped, or turned off.

This type of GFCI has two testing-related buttons on it. One button is appropriately labeled "TEST", and the other button is labeled "RESET". To test the GFCI receptacle follow these steps:

- Plug in an appliance (lamp or night light) into the outlet. The light should now be on. Then press the "TEST" button on the GFCI. The GFCI "RESET" button should pop out, and the light should go out.
- If the "RESET" button pops out, but the light doesn't go out, the GFCI has been improperly wired. In this case please contact a certified professional. There may also be a problem with other wiring in the same circuit.
- If the "RESET" button doesn't pop out, the GFCI is defective, or malfunctioned, and should be replaced.
- If the GFCI is functioning properly, and the lamp goes out, press the "RESET" button to restore power to the outlet.

Conversely, if you have a GFI that has tripped (which is common) and it will not reset, you may have a wiring short in the circuit, a defective appliance on the circuit, or the GFI itself has become defective. To test a tripping GFCI follow these steps:

- Remove every appliance connected to the GFCI's circuit and reset it. If it doesn't reset there may either be a wiring fault behind a socket outlet, or your GFCI itself has become faulty.
- Make sure whatever you are plugging into to the GFCI is dry and not damaged.
- Only plug in one item at a time. If you are plugging in a defective item it will cause the GFCI to trip, and that item therefore should be replaced.

If you are still having difficulty the easiest way to troubleshoot a GFI is to obtain a GFI tester, which is available at most hardware stores. It plugs into the GFI outlet, and will supply you with a "snapshot" of your connections, indicating wiring problems and/or the condition of the GFI. Another way to troubleshoot is to simply purchase a new GFI and install it.