

WALL SERVICE BENCH

3210, 3220, 3230, & 3240 SERIES
ASSEMBLY INSTRUCTIONS

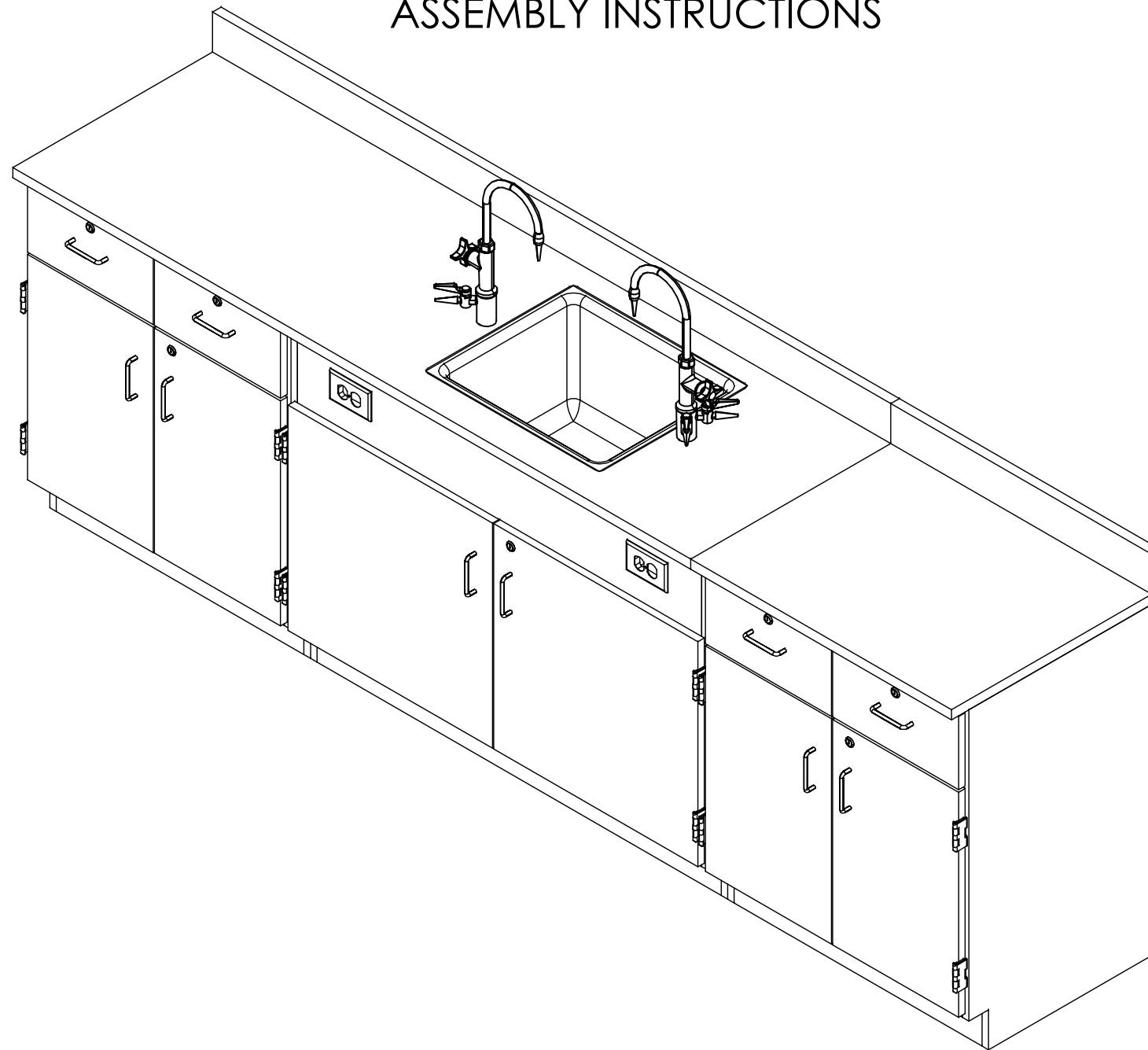

NOTE:

1. MODEL VIEWS MAY NOT REPRESENT EXACT MODEL PURCHASED

ALL DIMENSIONS ARE IN INCHES UNLESS NOTED OTHERWISE DECIMALS: .X = ± .030 .XX = ± .020 .XXX = ± .010 ANGLES: = ± 1° CABINET SQUARENESS = ± .0625	DWN BY:	EMR	DATE DWN:	4/13/15
	APR BY:		DATE APR:	
	APR BY:		DATE APR:	
	APR BY:		DATE APR:	

CONFIDENTIAL:
ALL DESIGN RIGHTS RESERVED.
THE INFORMATION, DATA, DESIGN, AND DRAWINGS EMBODIED IN THIS DOCUMENT AND ALL REPRODUCTIONS THEREOF ARE THE EXCLUSIVE PROPERTY OF DIVERSIFIED WOODCRAFTS, INC.

THESE DOCUMENTS ARE SUPPLIED WITH THE UNDERSTANDING THAT THEY WILL NOT BE DISCLOSED TO THIRD PARTIES WITHOUT WRITTEN CONSENT OF DIVERSIFIED WOODCRAFTS, INC. ANY REPRODUCTION IN PART OR WHOLE WITHOUT WRITTEN CONSENT IS SUBJECT TO LEGAL ACTION.



300 South Krueger Street
Suring, WI 54174
diversifiedwoodcrafts.com

TITLE:
WALL SERVICE BENCH
ASSEMBLY INSTRUCTIONS

REV.	DESCRIPTION	DATE	NAME	ECN NO.
C	UPDATED SILICONE PROCEDURE	8/23/23	RJM	-
A	CREATED ASSEMBLY INSTRUCTIONS	4/13/15	EMR	-

REVISION LEVEL

DRAWING NUMBER:	SCALE:	SHEET:	REVISION:
WALL SERVICE BENCH	NTS	1 OF 8	REV C

TOOLS REQUIRED

CONTACT CEMENT
PHILLIPS SCREW DRIVER
1/8" DRILL BIT
1/2" AND 9/16" WRENCHES
C-CLAMPS
SHIM STOCK (IF NEEDED)

ASSEMBLY COMPONENTS

ITEMS INCLUDED	PART #	PART DESCRIPTION	QTY
INNER CABINET	N/A	B81 - 48"W X 22"D X 35"H	1
OUTER CABINETS	N/A	B03, B06, B10, B16, AND/OR B21 - 30"W X 22"D X 35"H	2
TOP	VARIES	TOP(STYLE VARIES),1.00X78X24,BLK,FIXT	1
TOP	VARIES	TOP(STYLE VARIES),1.00X30X24,BLK,FLAT	1
TOP - BACKSPLASH	VARIES	TOP(STYLE VARIES),1.00X78X4,BLK,FLAT	1
TOP - BACKSPLASH	VARIES	TOP(STYLE VARIES),1.00X30X4,BLK,FLAT	1
SILICONE	100711	SILICONE,SEALANT,CLEAR	2
FIXTURE - FAUCETS	100074-BKR	FIXTURE,L65-WSA-DIV(MULTI-SERVICE)	2
FIXTURE - SINK	100699	SINK,EPOXY L30,BLK	1
FIXTURE - SINK TRAP	100056	SINK TRAP,PLASTIC ADJUSTABLE	1
FIXTURE - SINK OUTLET/STRAINER	254047	SINK OUTLET TAIL PIECE/INTEGRAL STRAINER,BLK	1
ELECTRICAL BOX	100033	ELECTRICAL BOX 3.00X2X2.50 DEEP	2
ELECTRICAL OUTLET	100034	ELEC,OUTLET,GFI,20A 125V, BLK	2
RUBBER BASE MOLDING	100283	RUBBER BASE MOLDING (SOLD BY FOOT)	12.50
STAINLESS STEEL CORNERS	100057	CORNERS-STAINLESS STEEL,BASE	2
SCREWS - BASE	100064	SCREW,#6X1/2 PTH SMS SS SCREW	8

NOTE:

- TOPS ARE EITHER EPOXY OR PHENOLIC.

REV.	DESCRIPTION	DATE	NAME	ECN NO.
C	UPDATED SILICONE PROCEDURE	8/23/23	RJM	-
A	CREATED ASSEMBLY INSTRUCTIONS	4/13/15	EMR	-
REVISION LEVEL				

ALL DIMENSIONS ARE IN INCHES UNLESS NOTED OTHERWISE DECIMALS: .X = ± .030 .XX = ± .020 .XXX = ± .010 ANGLES: = ± 1° CABINET SQUARENESS = ± .0625	DWN BY:	EMR	DATE DWN:	4/13/15
	APR BY:		DATE APR:	
	APR BY:		DATE APR:	
	APR BY:		DATE APR:	

CONFIDENTIAL:
 ALL DESIGN RIGHTS RESERVED.
 THE INFORMATION, DATA, DESIGN, AND DRAWINGS EMBODIED IN THIS DOCUMENT AND ALL REPRODUCTIONS THEREOF ARE THE EXCLUSIVE PROPERTY OF DIVERSIFIED WOODCRAFTS, INC.

THESE DOCUMENTS ARE SUPPLIED WITH THE UNDERSTANDING THAT THEY WILL NOT BE DISCLOSED TO THIRD PARTIES WITHOUT WRITTEN CONSENT OF DIVERSIFIED WOODCRAFTS, INC. ANY REPRODUCTION IN PART OR WHOLE WITHOUT WRITTEN CONSENT IS SUBJECT TO LEGAL ACTION.



300 South Krueger Street
 Suring, WI 54174
diversifiedwoodcrafts.com

TITLE:
WALL SERVICE BENCH TOOLS AND ASSEMBLY COMPONENTS

DRAWING NUMBER: WALL SERVICE BENCH	SCALE: NTS	SHEET: 2 OF 8	REVISION: REV C
--	---------------	------------------	--------------------

HARDWARE REQUIRED FOR STEP

QTY	DESCRIPTION	PART NUMBER
1	INNER CABINET	N/A

STEP 1:

- a. CENTER SINK CABINET OVER UTILITY HOOK-UPS.

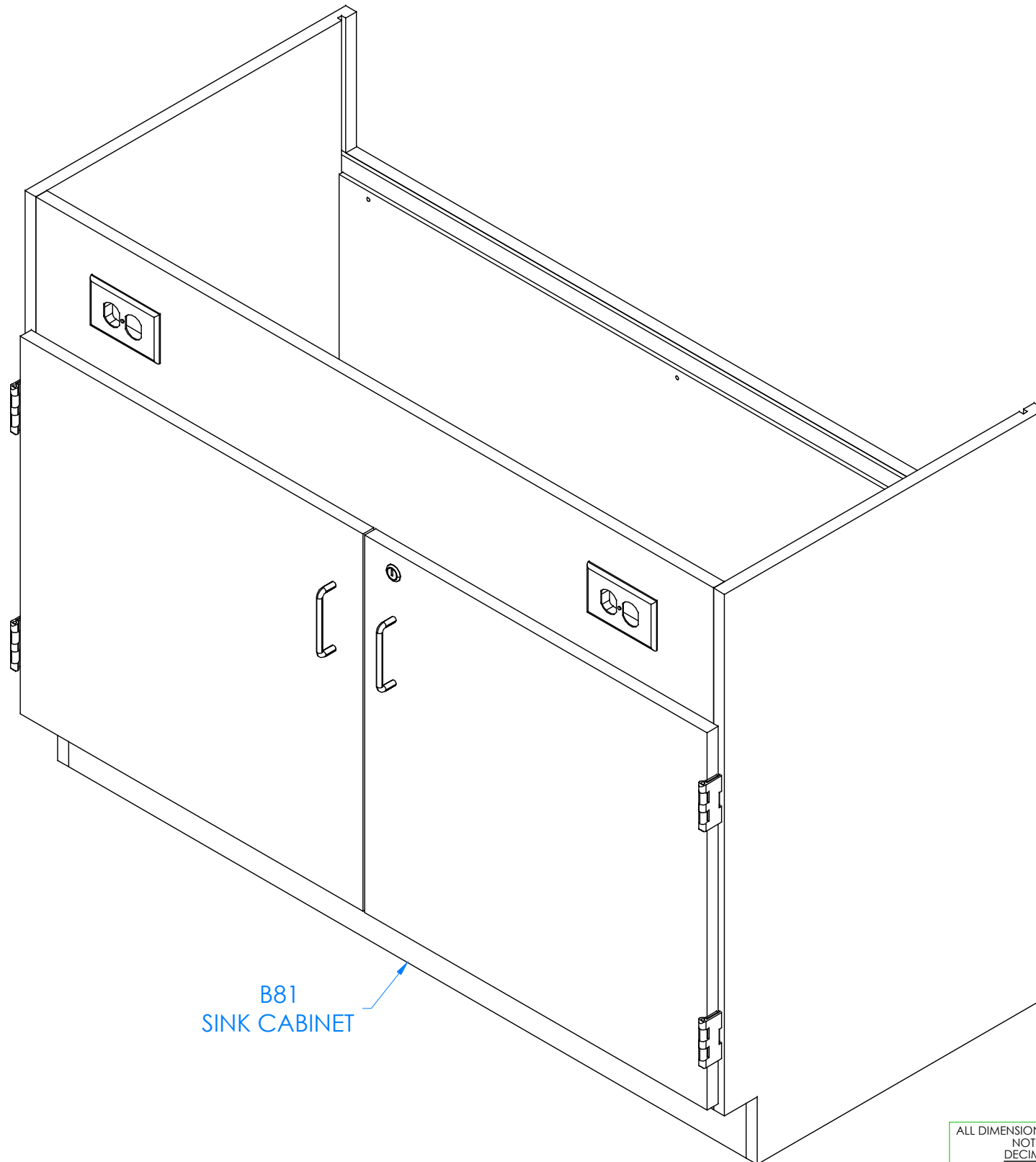

B81
SINK CABINET

NOTE:

1.

ALL DIMENSIONS ARE IN INCHES UNLESS NOTED OTHERWISE DECIMALS: .X = ± .030 .XX = ± .020 .XXX = ± .010 ANGLES: = ± 1° CABINET SQUARENESS = ± .0625	DWN BY: EMR APR BY: APR BY:	DATE DWN: 4/13/15 DATE APR: DATE APR:
---	-----------------------------------	---



300 South Krueger Street
Suring, WI 54174
diversifiedwoodcrafts.com

CONFIDENTIAL:
ALL DESIGN RIGHTS RESERVED.
THE INFORMATION, DATA, DESIGN, AND DRAWINGS EMBODIED IN THIS DOCUMENT AND ALL REPRODUCTIONS THEREOF ARE THE EXCLUSIVE PROPERTY OF DIVERSIFIED WOODCRAFTS, INC.

TITLE:
**WALL SERVICE BENCH
ASSEMBLY INSTRUCTIONS**

THESE DOCUMENTS ARE SUPPLIED WITH THE UNDERSTANDING THAT THEY WILL NOT BE DISCLOSED TO THIRD PARTIES WITHOUT WRITTEN CONSENT OF DIVERSIFIED WOODCRAFTS, INC. ANY REPRODUCTION IN PART OR WHOLE WITHOUT WRITTEN CONSENT IS SUBJECT TO LEGAL ACTION.

DRAWING NUMBER: WALL SERVICE BENCH	SCALE: NTS	SHEET: 3 OF 8	REVISION: REV C
--	---------------	------------------	--------------------

REV.	DESCRIPTION	DATE	NAME	ECN NO.
C	UPDATED SILICONE PROCEDURE	8/23/23	RJM	-
A	CREATED ASSEMBLY INSTRUCTIONS	4/13/15	EMR	-
REVISION LEVEL				

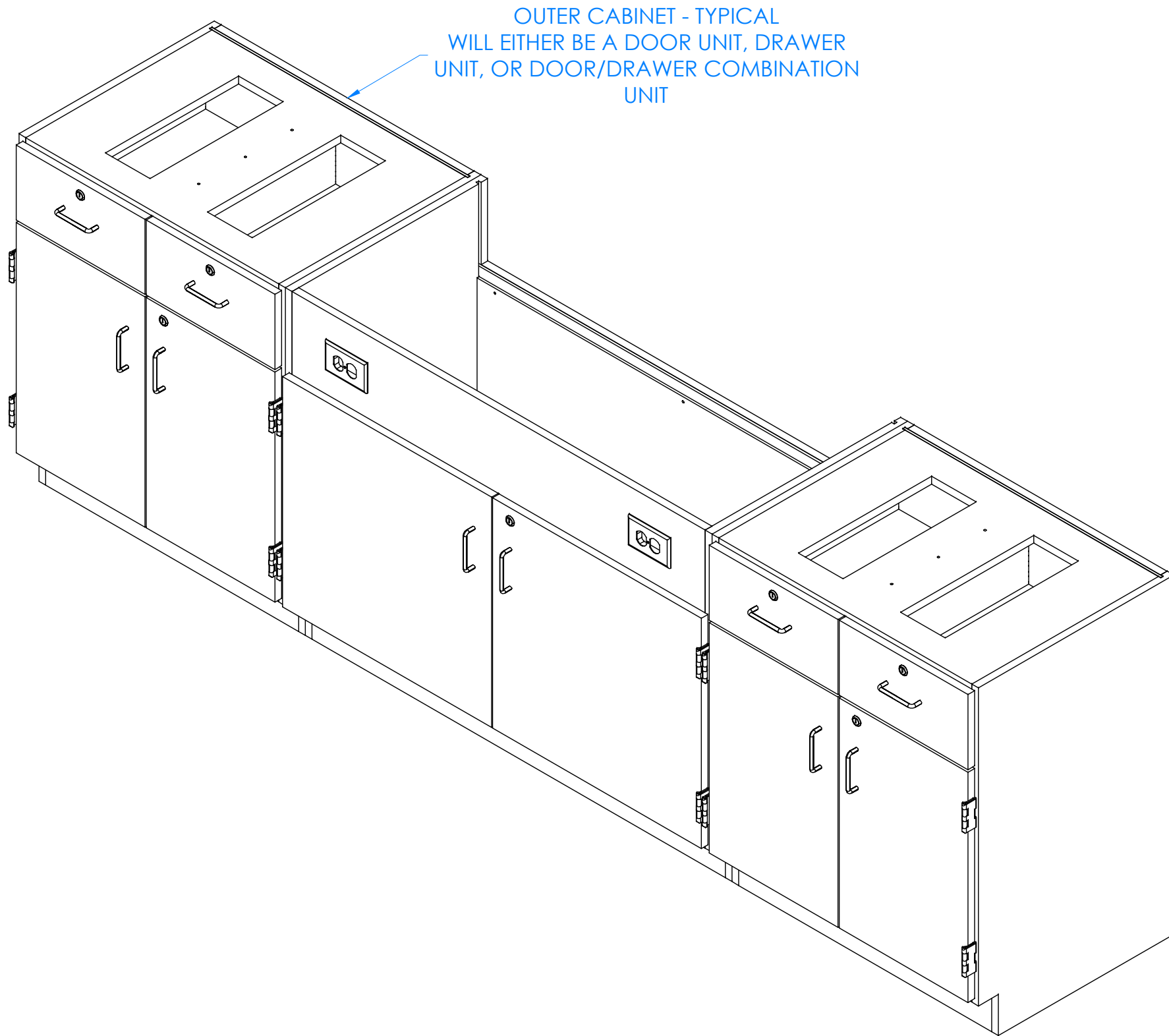

HARDWARE REQUIRED FOR STEP

QTY	DESCRIPTION	PART NUMBER
2	OUTER CABINETS	N/A

STEP 2:

- a. POSITION OTHER TWO CABINETS ON EITHER SIDE OF SINK CABINET.
- b. MAKE SURE ALL CABINETS ARE TIGHT TOGETHER.
- c. FASTEN CABINETS TO WALL.

NOTE:

1.

****NOTE****
CABINET MUST BE LEVELED OR DOORS AND DRAWERS MAY NOT OPEN OR CLOSE CORRECTLY

ALL DIMENSIONS ARE IN INCHES UNLESS NOTED OTHERWISE DECIMALS: .X = ± .030 .XX = ± .020 .XXX = ± .010 ANGLES: = ± 1° CABINET SQUARENESS = ± .0625	DWN BY: EMR APR BY: APR BY:	DATE DWN: 4/13/15 DATE APR: DATE APR:
---	-----------------------------------	---



300 South Krueger Street
Suring, WI 54174
diversifiedwoodcrafts.com

CONFIDENTIAL:
ALL DESIGN RIGHTS RESERVED.
THE INFORMATION, DATA, DESIGN, AND DRAWINGS EMBODIED IN THIS DOCUMENT AND ALL REPRODUCTIONS THEREOF ARE THE EXCLUSIVE PROPERTY OF DIVERSIFIED WOODCRAFTS, INC.

TITLE:
WALL SERVICE BENCH
ASSEMBLY INSTRUCTIONS

THESE DOCUMENTS ARE SUPPLIED WITH THE UNDERSTANDING THAT THEY WILL NOT BE DISCLOSED TO THIRD PARTIES WITHOUT WRITTEN CONSENT OF DIVERSIFIED WOODCRAFTS, INC. ANY REPRODUCTION IN PART OR WHOLE WITHOUT WRITTEN CONSENT IS SUBJECT TO LEGAL ACTION.

DRAWING NUMBER:	SCALE:	SHEET:	REVISION:
WALL SERVICE BENCH	NTS	4 OF 8	REV C

REV.	DESCRIPTION	DATE	NAME	ECN NO.
C	UPDATED SILICONE PROCEDURE	8/23/23	RJM	-
A	CREATED ASSEMBLY INSTRUCTIONS	4/13/15	EMR	-
REVISION LEVEL				

STEP 3:

- a. APPLY SILICONE ADHESIVE TO TOP EDGES OF CABINETS.
- b. APPLY SILICONE ADHESIVE IN DOT PATTERN LIKE SHOWN BELOW FOR BEST RESULTS.
- c. POSITION TOP OVER CABINETS.
- d. MAKE SURE ONE CUT EDGE OF THE TOP IS FLUSH WITH EDGE OF SINK CABINET.
- e. APPLY A BEAD OF ADHESIVE TO THE TWO EDGES OF TOPS AND PRESS FIRMLY TO CONNECT TOPS TOGETHER.
- f. BE SURE TOP IS TIGHT AGAINST WALL.
- g. CLAMP TOP TO RAIL/BASE EVERY 12" TO REMOVE ANY WARP, USING SHIMS AND C-CLAMPS, IF NEEDED, WHEN ALIGNING TOPS (DO THIS BEFORE ADHESIVE ON CABINET EDGES SETS UP).
- h. LET CURE FOR 6-12 HOURS.

HARDWARE REQUIRED FOR STEP

QTY	DESCRIPTION	PART NUMBER
1	TOP	VARIES
1	TOP	VARIES
2	SILICONE	100711

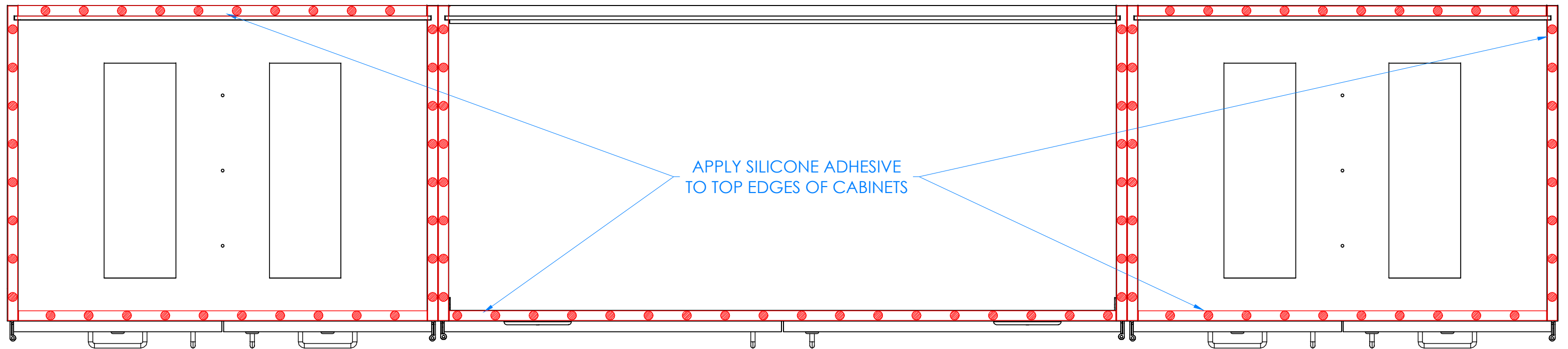

TOP VIEW OF WORKSTATION SHOWN

NOTE:

1.

ALL DIMENSIONS ARE IN INCHES UNLESS NOTED OTHERWISE	DWN BY:	EMR	DATE DWN:	4/13/15
DECIMALS: .X = ± .030	APR BY:		DATE APR:	
.XX = ± .020	APR BY:		DATE APR:	
.XXX = ± .010	APR BY:		DATE APR:	
ANGLES: = ± 1°				
CABINET SQUARENESS = ± .0625				



300 South Krueger Street
Suring, WI 54174
diversifiedwoodcrafts.com

CONFIDENTIAL:
ALL DESIGN RIGHTS RESERVED.
THE INFORMATION, DATA, DESIGN, AND DRAWINGS EMBODIED IN THIS DOCUMENT AND ALL REPRODUCTIONS THEREOF ARE THE EXCLUSIVE PROPERTY OF DIVERSIFIED WOODCRAFTS, INC.

TITLE:
WALL SERVICE BENCH
ASSEMBLY INSTRUCTIONS

THESE DOCUMENTS ARE SUPPLIED WITH THE UNDERSTANDING THAT THEY WILL NOT BE DISCLOSED TO THIRD PARTIES WITHOUT WRITTEN CONSENT OF DIVERSIFIED WOODCRAFTS, INC. ANY REPRODUCTION IN PART OR WHOLE WITHOUT WRITTEN CONSENT IS SUBJECT TO LEGAL ACTION.

REV.	DESCRIPTION	DATE	NAME	ECN NO.
C	UPDATED SILICONE PROCEDURE	8/23/23	RJM	-
A	CREATED ASSEMBLY INSTRUCTIONS	4/13/15	EMR	-

REVISION LEVEL

DRAWING NUMBER:	SCALE:	SHEET:	REVISION:
WALL SERVICE BENCH	NTS	5 OF 8	REV C

STEP 4:

- a. APPLY SILICONE ADHESIVE TO CUT EDGE OF BACKSPLASH IN DOT LIKE PATTERN SHOWN.
- b. POSITION IT ON BACK EDGE OF TOP ALONG THE WALL.
- c. APPLY A BEAD OF ADHESIVE ON EDGES OF BACKSPLASH WERE THE TWO SECTIONS MEET.
- d. MAKE SURE BACKSPLASH IS TIGHT AGAINST WALL AND ON CABINET TOP.
- e. APPLY ADHESIVE TO SINK OPENING ON TOP.
- f. LOWER SINK INTO OPENING.
- g. WIPE OFF ANY EXCESS CAULK AND ALLOW TO SET.
- h. LET CURE FOR 6-12 HOURS.

HARDWARE REQUIRED FOR STEP

QTY	DESCRIPTION	PART NUMBER
1	TOP - BACKSPLASH	VARIES
1	TOP - BACKSPLASH	VARIES
1	FIXTURE - SINK	100699
2	SILICONE	100711

APPLY SILICONE ADHESIVE HERE FOR BACKSPLASH

BACK EDGE

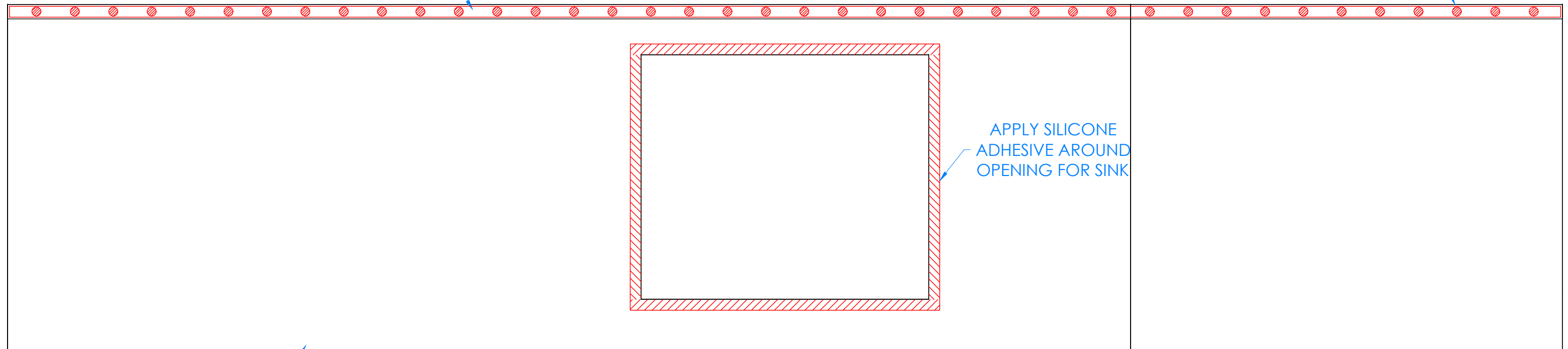

APPLY SILICONE ADHESIVE AROUND OPENING FOR SINK

TOP

TOP VIEW OF WORKSTATION SHOWN

NOTE:

1.

ALL DIMENSIONS ARE IN INCHES UNLESS NOTED OTHERWISE DECIMALS: .X = ± .030 .XX = ± .020 .XXX = ± .010 ANGLES: = ± 1° CABINET SQUARENESS = ± .0625	DWN BY:	EMR	DATE DWN:	4/13/15
	APR BY:		DATE APR:	
	APR BY:		DATE APR:	
	APR BY:		DATE APR:	



300 South Krueger Street
Suring, WI 54174
diversifiedwoodcrafts.com

CONFIDENTIAL:
ALL DESIGN RIGHTS RESERVED.
THE INFORMATION, DATA, DESIGN, AND DRAWINGS EMBODIED IN THIS DOCUMENT AND ALL REPRODUCTIONS THEREOF ARE THE EXCLUSIVE PROPERTY OF DIVERSIFIED WOODCRAFTS, INC.

TITLE:
WALL SERVICE BENCH
ASSEMBLY INSTRUCTIONS

THESE DOCUMENTS ARE SUPPLIED WITH THE UNDERSTANDING THAT THEY WILL NOT BE DISCLOSED TO THIRD PARTIES WITHOUT WRITTEN CONSENT OF DIVERSIFIED WOODCRAFTS, INC. ANY REPRODUCTION IN PART OR WHOLE WITHOUT WRITTEN CONSENT IS SUBJECT TO LEGAL ACTION.

REV.	DESCRIPTION	DATE	NAME	ECN NO.
C	UPDATED SILICONE PROCEDURE	8/23/23	RJM	-
A	CREATED ASSEMBLY INSTRUCTIONS	4/13/15	EMR	-
REVISION LEVEL				

DRAWING NUMBER:	SCALE:	SHEET:	REVISION:
WALL SERVICE BENCH	NTS	6 OF 8	REV C

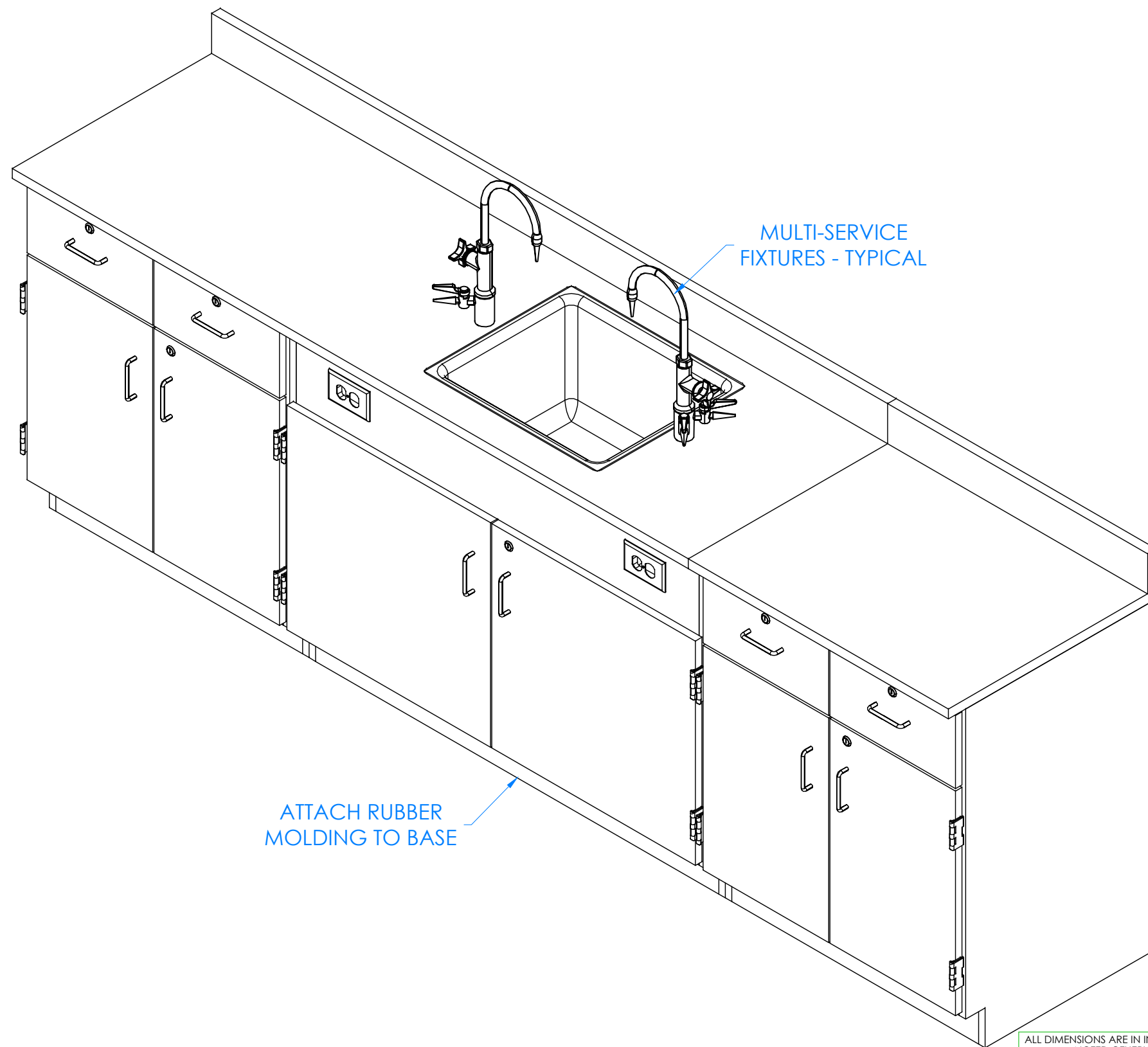

HARDWARE REQUIRED FOR STEP

QTY	DESCRIPTION	PART NUMBER
2	FIXTURE - FAUCETS	100074-BKR
1	FIXTURE - SINK TRAP	100056
1	FIXTURE - SINK OUTLET/STRAINER	254047
12.50	RUBBER BASE MOLDING	100283
2	STAINLESS STEEL CORNERS	100057
8	SCREWS - BASE	100064

STEP 5:

- a. INSTALL MULTI-SERVICE FIXTURES IN HOLES PROVIDED ON TOP.
- b. ATTACH RUBBER BASE MOLDING TO BASE OF CABINET USING CONTACT CEMENT.
- c. SCREW STAINLESS STEEL CORNER BRACKETS ON EACH CORNER OVER BASE MOLDING WITH HARDWARE PROVIDED.

ATTACH RUBBER MOLDING TO BASE

COMPLETE UNIT SHOWN

NOTE:

1. ALL WATER, ELECTRICAL, AND GAS CONNECTIONS SHOULD BE PERFORMED BY A TRAINED PROFESSIONAL PER LOCAL CODE.

ALL DIMENSIONS ARE IN INCHES UNLESS NOTED OTHERWISE DECIMALS: .X = ± .030 .XX = ± .020 .XXX = ± .010 ANGLES: = ± 1° CABINET SQUARENESS = ± .0625	DWN BY:	EMR	DATE DWN:	4/13/15
	APR BY:		DATE APR:	
	APR BY:		DATE APR:	
	APR BY:		DATE APR:	

CONFIDENTIAL:
ALL DESIGN RIGHTS RESERVED.
THE INFORMATION, DATA, DESIGN, AND DRAWINGS EMBODIED IN THIS DOCUMENT AND ALL REPRODUCTIONS THEREOF ARE THE EXCLUSIVE PROPERTY OF DIVERSIFIED WOODCRAFTS, INC.

THESE DOCUMENTS ARE SUPPLIED WITH THE UNDERSTANDING THAT THEY WILL NOT BE DISCLOSED TO THIRD PARTIES WITHOUT WRITTEN CONSENT OF DIVERSIFIED WOODCRAFTS, INC. ANY REPRODUCTION IN PART OR WHOLE WITHOUT WRITTEN CONSENT IS SUBJECT TO LEGAL ACTION.



300 South Krueger Street
Suring, WI 54174
diversifiedwoodcrafts.com

TITLE:
WALL SERVICE BENCH
ASSEMBLY INSTRUCTIONS

REV.	DESCRIPTION	DATE	NAME	ECN NO.
C	UPDATED SILICONE PROCEDURE	8/23/23	RJM	-
A	CREATED ASSEMBLY INSTRUCTIONS	4/13/15	EMR	-

REVISION LEVEL

DRAWING NUMBER:	SCALE:	SHEET:	REVISION:
WALL SERVICE BENCH	NTS	7 OF 8	REV C

TROUBLESHOOTING YOUR GFCI ELECTRICAL RECEPTACLE:

PLEASE NOTE: THROUGHOUT ANY OF THE FOLLOWING STEPS (PROCEDURES); IF YOU ARE NOT SURE YOU CAN DO THIS JOB SAFELY, AND COMPETENTLY, REFER THIS WORK TO QUALIFIED PROFESSIONAL!

If your unit comes equipped with a GFCI (Ground Fault Circuit Interrupter) electrical receptacle, and there is no power in the receptacle please consider/check the following:

- The extension cord (if being used) is working properly.
- The breaker hasn't been tripped, or turned off.

This type of GFCI has two testing-related buttons on it. One button is appropriately labeled "TEST", and the other button is labeled "RESET". To test the GFCI receptacle follow these steps:

- Plug in an appliance (lamp or night light) into the outlet. The light should now be on. Then press the "TEST" button on the GFCI. The GFCI "RESET" button should pop out, and the light should go out.
- If the "RESET" button pops out, but the light doesn't go out, the GFCI has been improperly wired. In this case please contact a certified professional. There may also be a problem with other wiring in the same circuit.
- If the "RESET" button doesn't pop out, the GFCI is defective, or malfunctioned, and should be replaced.
- If the GFCI is functioning properly, and the lamp goes out, press the "RESET" button to restore power to the outlet.

Conversely, if you have a GFI that has tripped (which is common) and it will not reset, you may have a wiring short in the circuit, a defective appliance on the circuit, or the GFI itself has become defective. To test a tripping GFCI follow these steps:

- Remove every appliance connected to the GFCI's circuit and reset it. If it doesn't reset there may either be a wiring fault behind a socket outlet, or your GFCI itself has become faulty.
- Make sure whatever you are plugging into to the GFCI is dry and not damaged.
- Only plug in one item at a time. If you are plugging in a defective item it will cause the GFCI to trip, and that item therefore should be replaced.

If you are still having difficulty the easiest way to troubleshoot a GFI is to obtain a GFI tester, which is available at most hardware stores. It plugs into the GFI outlet, and will supply you with a "snapshot" of your connections, indicating wiring problems and/or the condition of the GFI. Another way to troubleshoot is to simply purchase a new GFI and install it.