

**Figure 1**

## INSTALLATION INSTRUCTIONS

### *Before you begin*

These instructions illustrate the Stylmark® Rolling Door Assembly for Wood End Application (Models 610005, 610007 & 610099). If you have questions during assembly, call 800-328-2495 to reach technical assistance. This package does not include glass, wood screws or other door panels, which are necessary for complete assembly.

### *Tools you'll need*

- #2 Phillips screwdriver
- (2) Regular screwdrivers
- Scissors
- Rubber mallet
- Drill & bits
- #8 Wood screws (obtain locally)
- #8 Sheet metal screws (obtain locally)
- RTV Silicone (obtain locally if needed)

**Please read these instructions carefully before beginning installation.**

# Stylmark Rolling Door Assembly – Wood End

## Getting Started:

These instructions are for pre-fabricated rolling door assemblies. If assembly was not ordered as pre-fabricated, the stock length extrusions will need to be fabricated by the installer to meet the required dimensions of the project. Please note that part #110007 may be used as a channel, jamb & top channel depending on configuration of the rolling door ordered.

## Step-by-Step Instructions – Jamb Option:

1. If assembly was ordered with a jamb, determine jamb ordered (#110007 or #110061).
2. For assembly with jamb #110007, attach rolling door top channel to the underside of the wood case with #8 wood screws (obtain locally). **See Figure 2.** If jamb #110061 was ordered, skip to step #13.
3. Attach channel to the bottom of the wood case with #8 wood screws (obtain locally). **See Figure 3.**
4. Set channel #110007 into bottom of the case. Next, lay track #110009 into channel #110007. **See Figure 4.**
5. Attach jamb #110007 to side of case using #8 wood screws (obtain locally). **See Figure 5.**
6. Remove the adhesive backing from the rubber bumpers (part #221014) and attach them to side jambs uprights **See Figure 6A** and / or onto the center mullion (#110106 installed if over 62"). **See Figure 6B.** To install the center mullion, place the mullion between the top and bottom frame, no fasteners are needed.
7. Assemble the doorframe pieces. **See Figure 7.** Mark each piece for left or right door panel.
8. Cut lengths of black vinyl glazing tape to fit along bottom edge of the door panel. **See Figure 7.**
9. Fit the shoe onto the door panel and tap into place with a rubber mallet. **See Figure 8.**  
**Caution: If door height is taller than 36", RTV Silicone to the glass instead of glazing tape for extra stability.**
10. Place top guide #419007 on top of panel. **See Figure 7.**
11. Make sure the glazing materials fit evenly. Trim if necessary.
12. Repeat steps 7 through 11 for the other door panel.

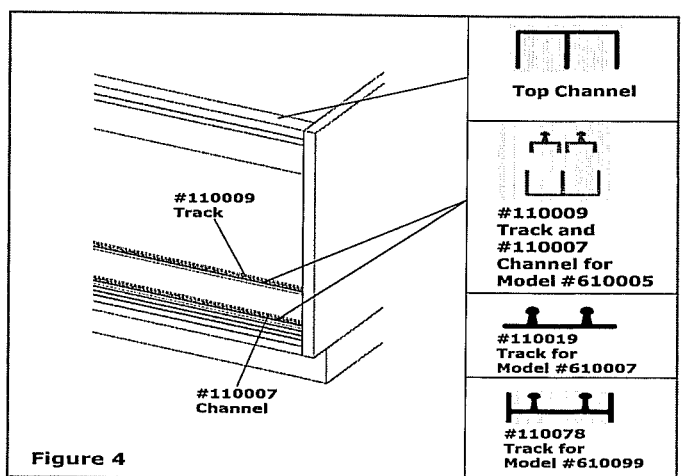
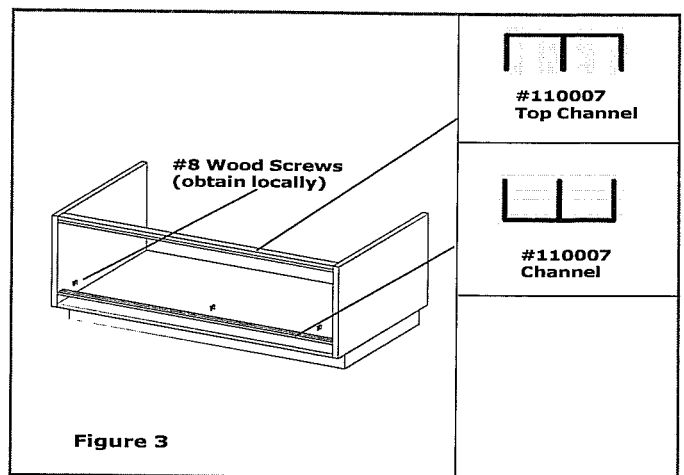
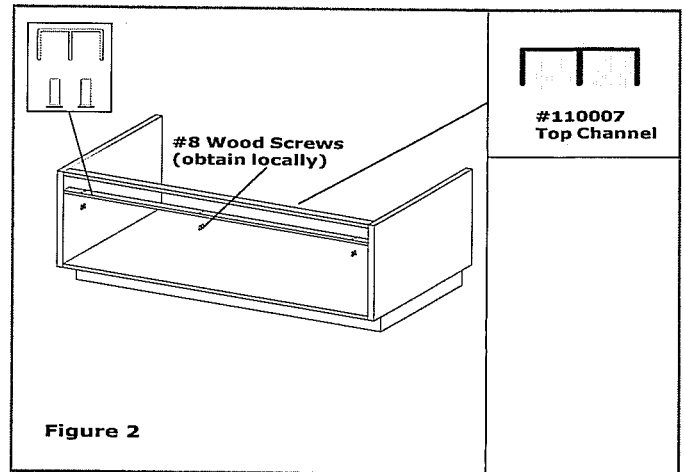

# Stylmark Installation Instructions: Models 610005, 610007, & 610099

## Rolling Door Assembly – Wood End

13. For assembly with jamb #110061, attach jamb to side of case with #8 wood screws (obtain locally). **See Figure 5.**
14. Attach rolling door header to the underside of the wood case with #8 wood screws (obtain locally). **See Figure 2.**
15. Attach channel to the bottom of the wood case with #8 wood screws (obtain locally). **See Figure 3.**
16. Lay track #110009 into channel #110007. **See Figure 4.**
17. Remove the adhesive backing from the rubber bumpers (part #221015) and attach them to side jambs uprights **See Figure 6A** and / or onto the center mullion (#110106 installed if over 62"). **See Figure 6B.** To install the center mullion, place the mullion between the top and bottom frame, no fasteners are needed.
18. Assemble the doorframe pieces. **See Figure 7.** Mark each piece for left or right door panel.
19. Cut lengths of black vinyl glazing tape to fit along bottom edge of the door panel. **See Figure 7.**
20. Fit the shoe onto the door panel and tap into place with a rubber mallet. **See Figure 8.**  
**Caution: If door height is taller than 36", RTV Silicone to the glass instead of glazing tape for extra stability.**
21. Place top guide #419007 on top of panel. **See Figure 7.**
22. Make sure the glazing materials fit evenly. Trim if necessary.
23. Repeat steps 18 through 22 for the other door panel.

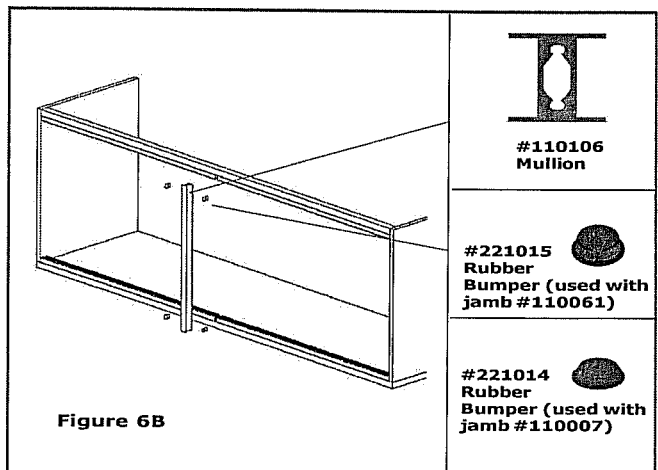
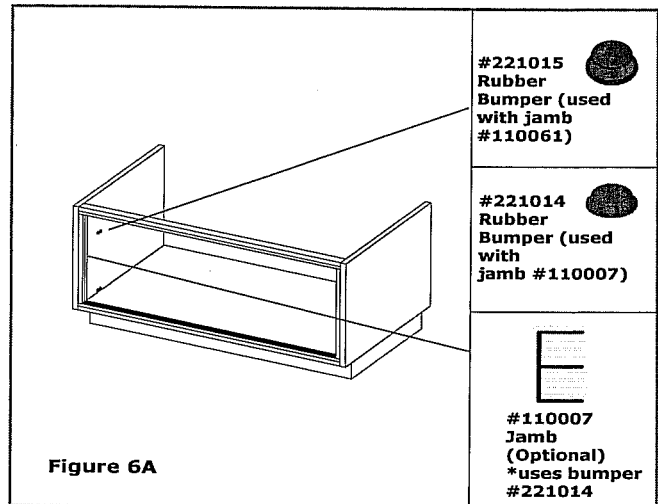
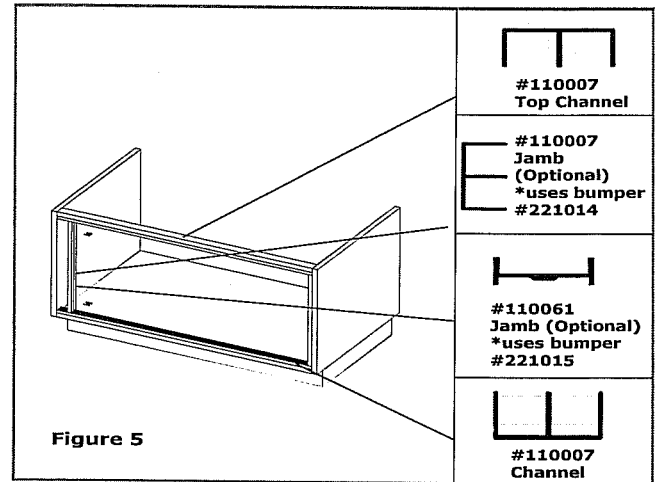

# Stylmark Installation Instructions: Models 610005, 610007, & 610099 Rolling Door Assembly – Wood End

## Step-by-Step Instructions – No Jamb Option:

1. If no jambs were ordered, attach rolling door top channel to the underside of the wood case with #8 wood screws (obtain locally). **See Figure 2.**
2. Attach channel to bottom of wood case with #8 wood screws (obtain locally). **See Figure 3.**
3. Assemble the doorframe pieces. **See Figure 7.** Mark each piece for left or right door panel.
4. Cut lengths of black vinyl glazing tape to fit along bottom edge of the door panel. **See Figure 7.**
5. Fit the shoe onto the door panel and tap into place with a rubber mallet. **See Figure 8.**  
**Caution: If glass height is taller than 36", RTV Silicone to the glass instead of glazing tape for extra stability.**
6. Place top guide #419007 on top of panel. **See Figure 7.**
7. Make sure the glazing materials fit evenly. Trim if necessary.
8. Repeat steps 3 through 7 for the other door panel.

