

MOBILE DEMO CART

4501 & 4502 (OAK OR MAPLE)
ASSEMBLY INSTRUCTIONS

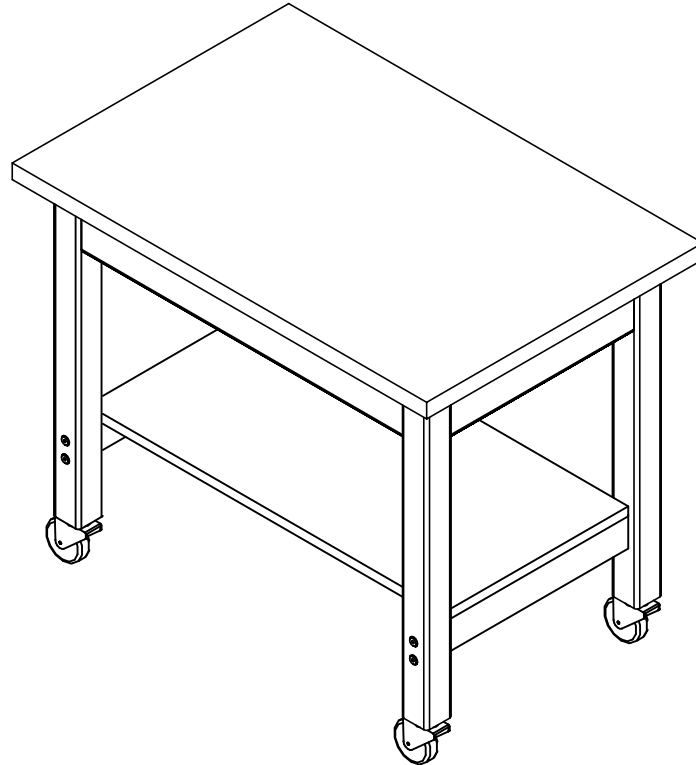

NOTE:

1. MODEL VIEWS MAY NOT REPRESENT EXACT MODEL PURCHASED

ALL DIMENSIONS ARE IN INCHES UNLESS NOTED OTHERWISE	DWN BY:	EMR	DATE DWN:	11/15/16
DECIMALS: $\frac{X}{1000} = \pm .000$	APR BY:		DATE APR:	
XX = $\pm .020$	APR BY:		DATE APR:	
XXX = $\pm .010$	APR BY:		DATE APR:	
ANGLES: $\pm 1^{\circ}$	APR BY:		DATE APR:	
CABINET SQUARENESS: $\pm .0625$	APR BY:		DATE APR:	

CONFIDENTIAL:
ALL DESIGN RIGHTS RESERVED
THE INFORMATION, DATA, DESIGN, AND DRAWINGS EMBODIED IN THIS DOCUMENT AND ALL REPRODUCTIONS THEREOF ARE THE EXCLUSIVE PROPERTY OF DIVERSIFIED WOODCRAFTS, INC.

THESE DOCUMENTS ARE SUPPLIED WITH THE UNDERSTANDING THAT THEY WILL NOT BE DISCLOSED TO THIRD PARTIES WITHOUT WRITTEN CONSENT OF DIVERSIFIED WOODCRAFTS, INC. ANY REPRODUCTION IN PART OR WHOLE WITHOUT WRITTEN CONSENT IS SUBJECT TO LEGAL ACTION.



300 South Krueger Street
Suring, WI 54174
diversifiedwoodcrafts.com

TITLE:
MOBILE DEMO CART
ASSEMBLY INSTRUCTIONS

REV.	DESCRIPTION	DATE	NAME	ECN NO.
A	CREATED ASSEMBLY INSTRUCTIONS	11/15/16	EMR	-

REVISION LEVEL

DRAWING NUMBER:	4501 & 4502	SCALE:	NTS	SHEET:	1 OF 7	REVISION:	REV A
-----------------	-------------	--------	-----	--------	--------	-----------	-------

TOOLS REQUIRED

1/2" WRENCH
1/2" SOCKET AND TORQUE WRENCH - OPTIONAL
4MM ALLEN WRENCH
SCREW DRIVER

ASSEMBLY COMPONENTS

ITEMS INCLUDED	PART #	PART DESCRIPTION	QTY
TOP AND APRON ASSEMBLY	N/A	TOP ASSEMBLY (FACTORY ASSEMBLED)	1
LEGS WITH CASTERS	VARIES	LEG (MATERIAL VARIES) 2.25X2.25X28.25	4
BRACES	N/A	LEG BRACE - 16.00" LONG	2
SHELF	N/A	SHELF - 15.875" W X 31.125" L	1
CONFIRMATS - LEGS	227578	SCREW,7MMX90MM,CONN,ALLENHEAD, BLACK	8
SCREWS - SHELF	100066	SCREW,#8X1.5 FSQ SMS TYPE 17	4
WASHER - CORNER LEG BRACKET	100039	WASHER,SPLIT LOCK 5/16	4
HEX NUT - CORNER LEG BRACKET	100044	NUT,HEX 5/16-18 STEEL ZINC	4

NOTE:

- TOPS ARE EITHER PLASTIC LAMINATE OR CHEMGUARD.

ALL DIMENSIONS ARE IN INCHES UNLESS NOTED OTHERWISE DECIMALS: X = ± .030 XX = ± .020 XXX = ± .010 ANGLES: = ± 1° CABINET SQUARENESS: = ± .0625	DWN BY: EMR	DATE DWN: 11/15/16
	APR BY:	DATE APR:
	APR BY:	DATE APR:



300 South Krueger Street
Suring, WI 54174
diversifiedwoodcrafts.com

CONFIDENTIAL:
ALL DESIGN RIGHTS RESERVED
THE INFORMATION, DATA, DESIGN, AND DRAWINGS EMBODIED IN THIS DOCUMENT AND ALL REPRODUCTIONS THEREOF ARE THE EXCLUSIVE PROPERTY OF DIVERSIFIED WOODCRAFTS, INC.

TITLE:
MOBILE DEMO CART
TOOLS AND ASSEMBLY COMPONENTS

THESE DOCUMENTS ARE SUPPLIED WITH THE UNDERSTANDING THAT THEY WILL NOT BE DISCLOSED TO THIRD PARTIES WITHOUT WRITTEN CONSENT OF DIVERSIFIED WOODCRAFTS, INC. ANY REPRODUCTION IN PART OR WHOLE WITHOUT WRITTEN CONSENT IS SUBJECT TO LEGAL ACTION.

DRAWING NUMBER: 4501 & 4502	SCALE: NTS	SHEET: 2 OF 7	REVISION: REV A
---	---------------	------------------	--------------------

REV.	DESCRIPTION	DATE	NAME	ECN NO.
A	CREATED ASSEMBLY INSTRUCTIONS	11/15/16	EMR	-
REVISION LEVEL				

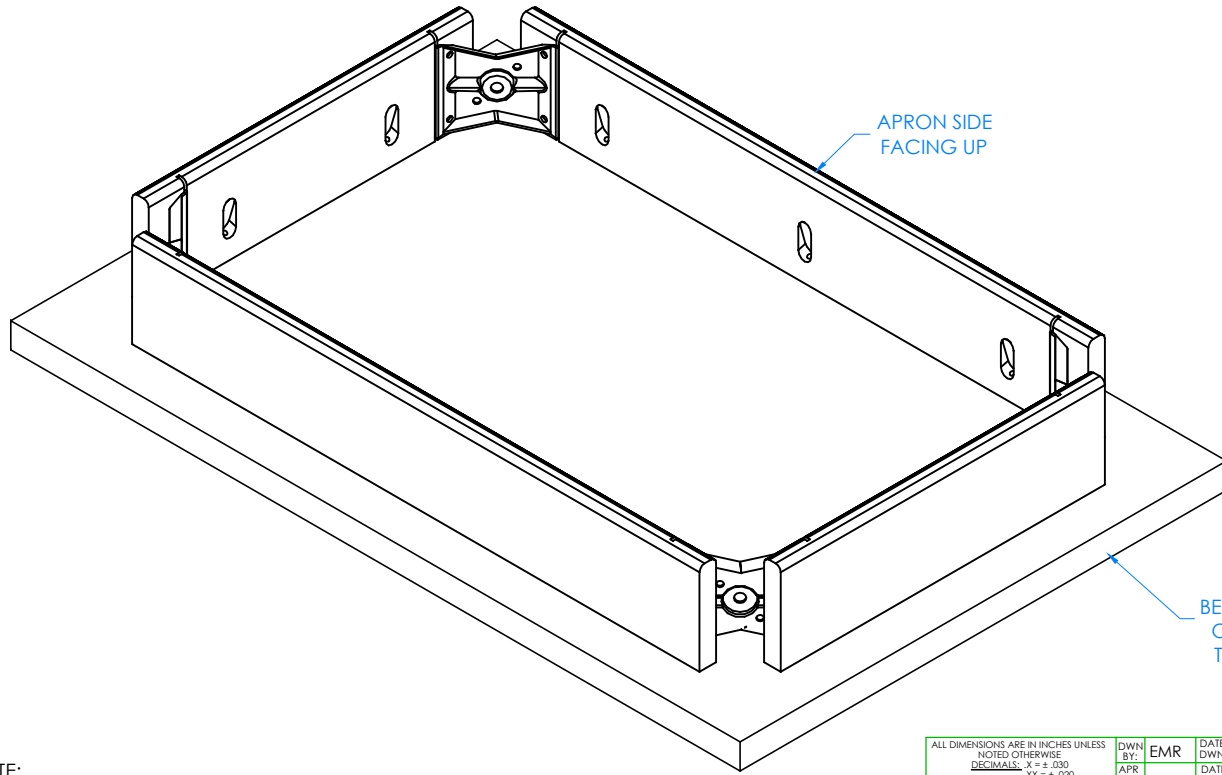

STEP 1:

- LAY TOP ASSEMBLY ON FLOOR WITH APRON SIDE FACING UP.

NOTE:

1.

ALL DIMENSIONS ARE IN INCHES UNLESS NOTED OTHERWISE	DWN BY:	EMR	DATE DWN:	11/15/16
DECIMALS: $\frac{1}{16}$ = ± .030	APR BY:		DATE APR:	
XX = ± .020	APR BY:		DATE APR:	
.XXX = ± .010	APR BY:		DATE APR:	
ANGLES: = ± 1°	APR BY:		DATE APR:	
CABINET SQUARENESS: = ± .0625	APR BY:		DATE APR:	

CONFIDENTIAL:
ALL DESIGN RIGHTS RESERVED
THE INFORMATION, DATA, DESIGN, AND DRAWINGS EMBODIED IN THIS DOCUMENT AND ALL REPRODUCTIONS THEREOF ARE THE EXCLUSIVE PROPERTY OF DIVERSIFIED WOODCRAFTS, INC.

THESE DOCUMENTS ARE SUPPLIED WITH THE UNDERSTANDING THAT THEY WILL NOT BE DISCLOSED TO THIRD PARTIES WITHOUT WRITTEN CONSENT OF DIVERSIFIED WOODCRAFTS, INC. ANY REPRODUCTION IN PART OR WHOLE WITHOUT WRITTEN CONSENT IS SUBJECT TO LEGAL ACTION.



300 South Krueger Street
Suring, WI 54174
diversifiedwoodcrafts.com

TITLE:
MOBILE DEMO CART
ASSEMBLY INSTRUCTIONS

REV.	DESCRIPTION	DATE	NAME	ECN NO.
A	CREATED ASSEMBLY INSTRUCTIONS	11/15/16	EMR	-
REVISION LEVEL				

DRAWING NUMBER:	SCALE:	SHEET:	REVISION:
4501 & 4502	NTS	3 OF 7	REV A

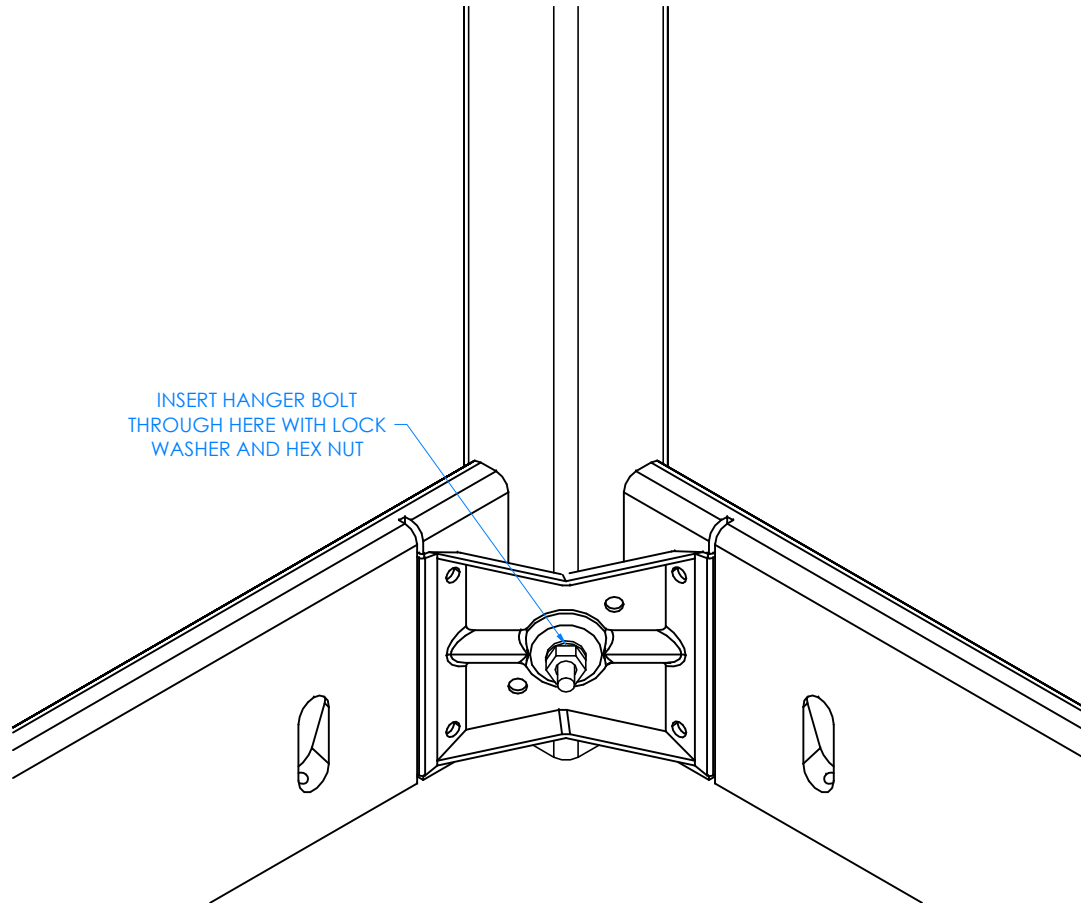

CLOSE UP OF CORNER LEG ASSEMBLY

STEP 2:

- INSERT HANGER BOLT ON ONE LEG THROUGH THE CORNER BRACKET AND INSERT LOCK WASHER AND HEX NUT.
- SCREW ON NUT USING A 1/2" WRENCH OR 1/2" SOCKET AND TORQUE WRENCH.
- DO NOT TIGHTEN ALL THE WAY.
- REPEAT FOR OTHER LEGS.

NOTE:

1.

ALL DIMENSIONS ARE IN INCHES UNLESS NOTED OTHERWISE	DWN BY:	EMR	DATE DWN:	11/15/16
DECIMALS: X = ± .030	APR BY:		DATE APR:	
XX = ± .020	APR BY:		DATE APR:	
XXX = ± .010	APR BY:		DATE APR:	
ANGLES: = ± 1°	APR BY:		DATE APR:	
CABINET SQUARENESS: = ± .0625	APR BY:		DATE APR:	

CONFIDENTIAL:
ALL DESIGN RIGHTS RESERVED
THE INFORMATION, DATA, DESIGN, AND DRAWINGS EMBODIED IN THIS DOCUMENT AND ALL REPRODUCTIONS THEREOF ARE THE EXCLUSIVE PROPERTY OF DIVERSIFIED WOODCRAFTS, INC.

THESE DOCUMENTS ARE SUPPLIED WITH THE UNDERSTANDING THAT THEY WILL NOT BE DISCLOSED TO THIRD PARTIES WITHOUT WRITTEN CONSENT OF DIVERSIFIED WOODCRAFTS, INC. ANY REPRODUCTION IN PART OR WHOLE WITHOUT WRITTEN CONSENT IS SUBJECT TO LEGAL ACTION.



300 South Krueger Street
Suring, WI 54174
diversifiedwoodcrafts.com

TITLE:
MOBILE DEMO CART
ASSEMBLY INSTRUCTIONS

REV.	DESCRIPTION	DATE	NAME	ECN NO.
A	CREATED ASSEMBLY INSTRUCTIONS	11/15/16	EMR	-
REVISION LEVEL				

DRAWING NUMBER:	SCALE:	SHEET:	REVISION:
4501 & 4502	NTS	4 OF 7	REV A

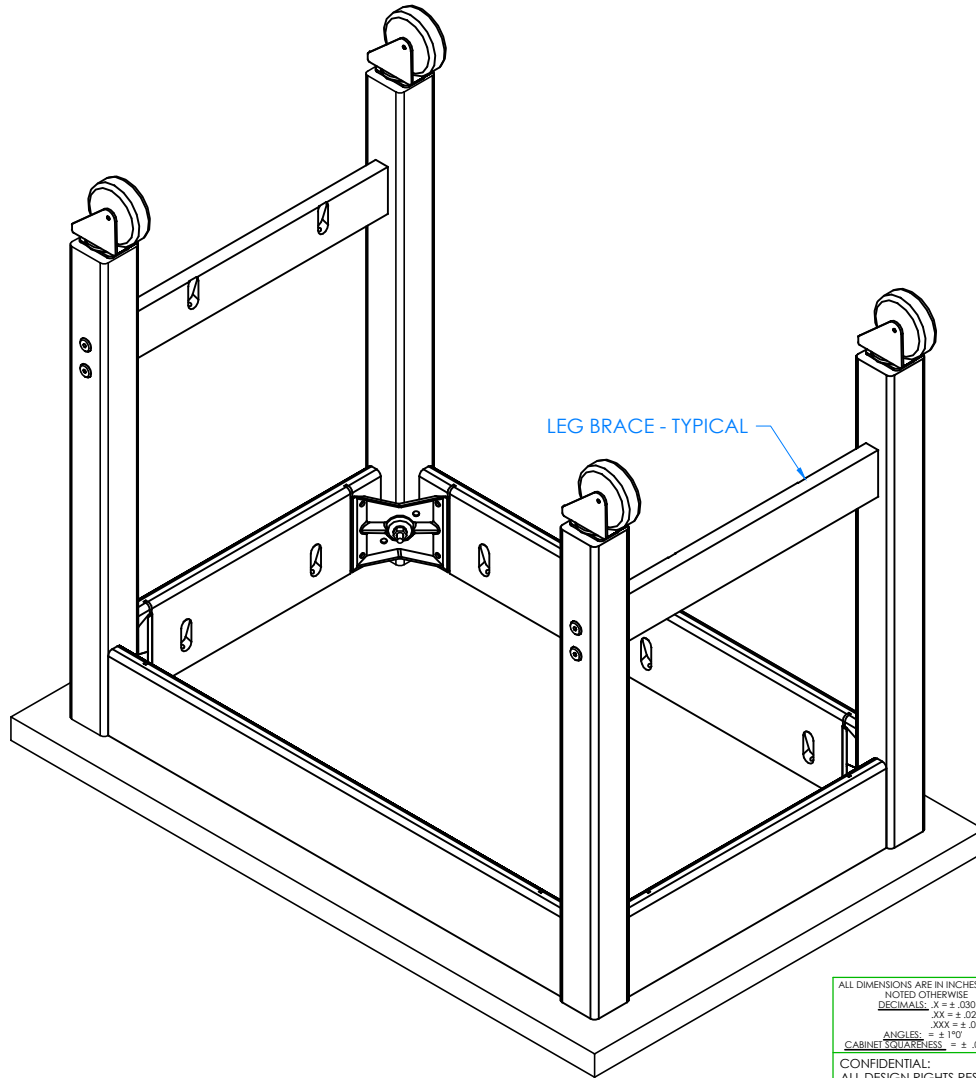

STEP 3:

- ATTACH BRACES TO LEGS.
- INSERT THE CONFIRMATS INTO ONE LEG AND SCREW INTO THE BRACE.
- REPEAT ON OTHER LEGS.
- MAKE SURE BRACES ARE STRAIGHT AND ALL CONFIRMATS ARE TIGHT.
- GO BACK TO STEP 2 AND TIGHTEN UP THE HANGER BOLTS FOR EACH LEG USING A 1/2" WRENCH OR 1/2" SOCKET AND TORQUE WRENCH, TO A MINIMUM OF 12FT LBS BUT NOT TO EXCEED 17FT LBS.

NOTE:

1.

ALL DIMENSIONS ARE IN INCHES UNLESS NOTED OTHERWISE	DWN BY:	EMR	DATE DWN:	11/15/16
DECIMALS: X = ± .030	APR BY:		DATE APR:	
XX = ± .020	APR BY:		DATE APR:	
XXX = ± .010	APR BY:		DATE APR:	
ANGLES: = ± 1°	APR BY:		DATE APR:	
CABINET SQUARENESS: = ± .0625	APR BY:		DATE APR:	

CONFIDENTIAL:
 ALL DESIGN RIGHTS RESERVED
 THE INFORMATION, DATA, DESIGN, AND DRAWINGS EMBODIED IN THIS DOCUMENT AND ALL REPRODUCTIONS THEREOF ARE THE EXCLUSIVE PROPERTY OF DIVERSIFIED WOODCRAFTS, INC.

THESE DOCUMENTS ARE SUPPLIED WITH THE UNDERSTANDING THAT THEY WILL NOT BE DISCLOSED TO THIRD PARTIES WITHOUT WRITTEN CONSENT OF DIVERSIFIED WOODCRAFTS, INC. ANY REPRODUCTION IN PART OR WHOLE WITHOUT WRITTEN CONSENT IS SUBJECT TO LEGAL ACTION.



300 South Krueger Street
 Suring, WI 54174
 diversifiedwoodcrafts.com

TITLE:
 MOBILE DEMO CART
 ASSEMBLY INSTRUCTIONS

REV.	DESCRIPTION	DATE	NAME	ECN NO.
A	CREATED ASSEMBLY INSTRUCTIONS	11/15/16	EMR	-
REVISION LEVEL				

DRAWING NUMBER:	SCALE:	SHEET:	REVISION:
4501 & 4502	NTS	5 OF 7	REV A

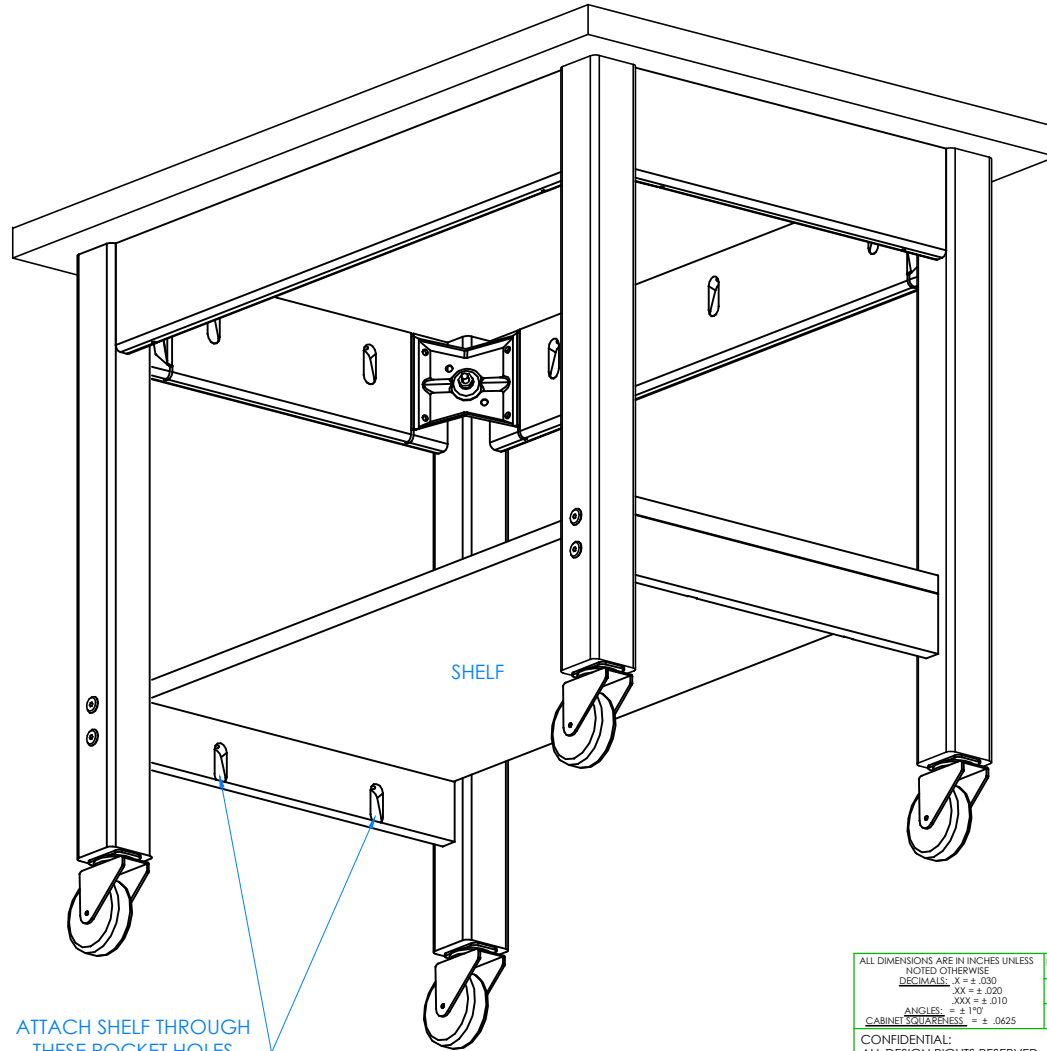

STEP 4:

- TURN TABLE OVER SO TOP IS UP.
- ATTACH SHELF TO BRACES BY SCREWING INTO POCKET HOLES LOCATED ON EACH BRACE WITH HARDWARE PROVIDED.

NOTE:

1.

ATTACH SHELF THROUGH THESE POCKET HOLES (BOTH BRACES)

UNDERSIDE OF TABLE SHOWN

ALL DIMENSIONS ARE IN INCHES UNLESS NOTED OTHERWISE	DWN BY:	EMR	DATE DWN:	11/15/16
DECIMALS: $\frac{1}{16} = \pm .030$	APR BY:		DATE APR:	
XX = $\pm .020$	APR BY:		DATE APR:	
.XXX = $\pm .010$	APR BY:		DATE APR:	
ANGLES: $\pm 1^{\circ}$	APR BY:		DATE APR:	
CABINET SQUARENESS: $\pm .0625$	APR BY:		DATE APR:	

CONFIDENTIAL:
ALL DESIGN RIGHTS RESERVED
THE INFORMATION, DATA, DESIGN, AND DRAWINGS EMBODIED IN THIS DOCUMENT AND ALL REPRODUCTIONS THEREOF ARE THE EXCLUSIVE PROPERTY OF DIVERSIFIED WOODCRAFTS, INC.

THESE DOCUMENTS ARE SUPPLIED WITH THE UNDERSTANDING THAT THEY WILL NOT BE DISCLOSED TO THIRD PARTIES WITHOUT WRITTEN CONSENT OF DIVERSIFIED WOODCRAFTS, INC. ANY REPRODUCTION IN PART OR WHOLE WITHOUT WRITTEN CONSENT IS SUBJECT TO LEGAL ACTION.



300 South Krueger Street
Suring, WI 54174
diversifiedwoodcrafts.com

TITLE:
MOBILE DEMO CART
ASSEMBLY INSTRUCTIONS

REV.	DESCRIPTION	DATE	NAME	ECN NO.
A	CREATED ASSEMBLY INSTRUCTIONS	11/15/16	EMR	-
REVISION LEVEL				

DRAWING NUMBER:	SCALE:	SHEET:	REVISION:
4501 & 4502	NTS	6 OF 7	REV A

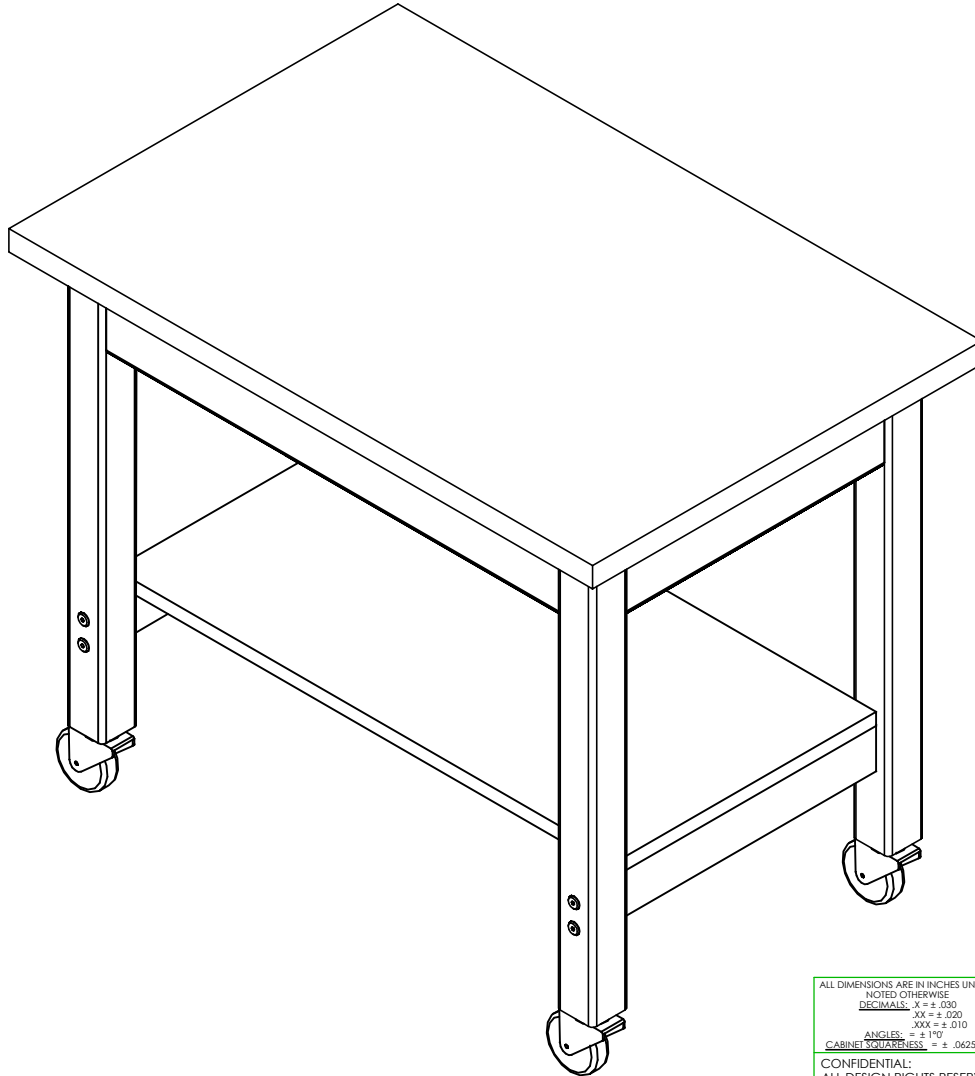

STEP 5:

- SET TABLE IN PLACE.

NOTE:

- 1.

COMPLETE UNIT SHOWN

ALL DIMENSIONS ARE IN INCHES UNLESS NOTED OTHERWISE	DWN BY:	EMR	DATE DWN:	11/15/16
DECIMALS: X = ± .030	APR BY:		DATE APR:	
XX = ± .020	APR BY:		DATE APR:	
XXX = ± .010	APR BY:		DATE APR:	
ANGLES: = ± 1°	APR BY:		DATE APR:	
CABINET SQUARENESS: = ± .0625	APR BY:		DATE APR:	

CONFIDENTIAL:
ALL DESIGN RIGHTS RESERVED
THE INFORMATION, DATA, DESIGN, AND DRAWINGS EMBODIED IN THIS DOCUMENT AND ALL REPRODUCTIONS THEREOF ARE THE EXCLUSIVE PROPERTY OF DIVERSIFIED WOODCRAFTS, INC.

THESE DOCUMENTS ARE SUPPLIED WITH THE UNDERSTANDING THAT THEY WILL NOT BE DISCLOSED TO THIRD PARTIES WITHOUT WRITTEN CONSENT OF DIVERSIFIED WOODCRAFTS, INC. ANY REPRODUCTION IN PART OR WHOLE WITHOUT WRITTEN CONSENT IS SUBJECT TO LEGAL ACTION.



300 South Krueger Street
Suring, WI 54174
diversifiedwoodcrafts.com

TITLE:
MOBILE DEMO CART
ASSEMBLY INSTRUCTIONS

REV.	DESCRIPTION	DATE	NAME	ECN NO.
A	CREATED ASSEMBLY INSTRUCTIONS	11/15/16	EMR	-
REVISION LEVEL				

DRAWING NUMBER:	SCALE:	SHEET:	REVISION:
4501 & 4502	NTS	7 OF 7	REV A