

SCULPTURE WARE CART

5100M ASSEMBLY INSTRUCTIONS

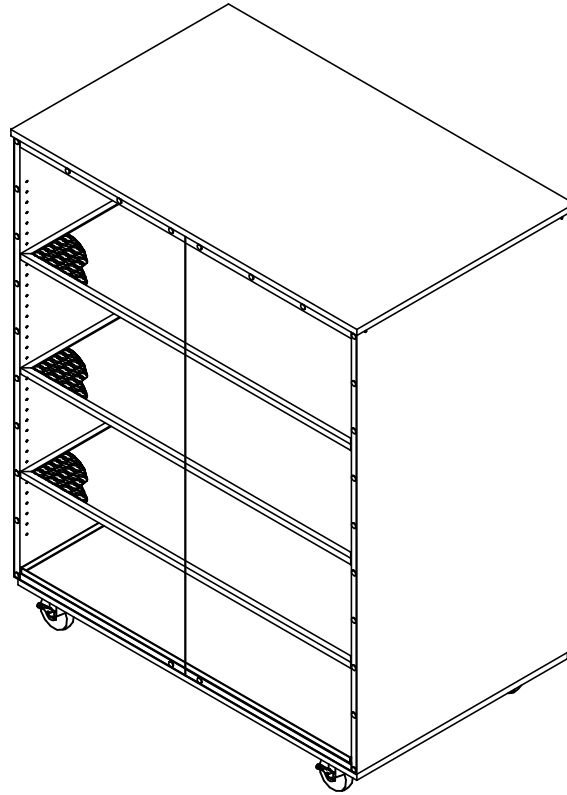

NOTE:

1. MODEL VIEWS MAY NOT REPRESENT EXACT MODEL PURCHASED

| | | |
|--------------------------------------------------------------------------------------------------------------------------------------------------------------|-------------|------------------|
| ALL DIMENSIONS ARE IN INCHES UNLESS NOTED OTHERWISE DECIMALS: X = ± .020 XX = ± .020 XXX = ± .010 ANGLES: = ± 1° CABINET SQUARENESS = ± .0625 | DWN BY: EMR | DATE DWN: 3/4/14 |
| | APR BY: | DATE APR: |
| | APR BY: | DATE APR: |

CONFIDENTIAL:
ALL DESIGN RIGHTS RESERVED
THE INFORMATION, DATA, DESIGN, AND DRAWINGS EMBODIED IN THIS DOCUMENT AND ALL REPRODUCTIONS THEREOF ARE THE EXCLUSIVE PROPERTY OF DIVERSIFIED WOODCRAFTS, INC.

THESE DOCUMENTS ARE SUPPLIED WITH THE UNDERSTANDING THAT THEY WILL NOT BE DISCLOSED TO THIRD PARTIES WITHOUT WRITTEN CONSENT OF DIVERSIFIED WOODCRAFTS, INC. ANY REPRODUCTION IN PART OR WHOLE WITHOUT WRITTEN CONSENT IS SUBJECT TO LEGAL ACTION.



300 South Krueger Street
Suring, WI 54174
diversifiedwoodcrafts.com

TITLE:
SCULPTURE WARE CART
ASSEMBLY INSTRUCTIONS

| REV. | DESCRIPTION | DATE | NAME | ECN NO. |
|----------------|-------------------------------|--------|------|---------|
| A | CREATED ASSEMBLY INSTRUCTIONS | 3/4/14 | EMR | - |
| REVISION LEVEL | | | | |

| | | | |
|--------------------------|---------------|------------------|--------------------|
| DRAWING NUMBER: 5100M | SCALE: NTS | SHEET: 1 OF 4 | REVISION: REV A |
|--------------------------|---------------|------------------|--------------------|

ASSEMBLY COMPONENTS

| ITEMS INCLUDED | PART # | PART DESCRIPTION | QTY |
|------------------|--------|------------------------------------------------------------------|-----|
| CASTER ASSEMBLY | 100081 | CASTER,ASSY,HARDWARE,16-SCREWS,16-NUTS (FACTORY ASSEMBLED) | 1 |
| SHELF PINS | 100183 | SHELF PINS, 5MM SLOPING | 24 |
| SHELF | 238949 | SHELF,EXPANDED METAL,DRYING CABINET | 6 |
| DRIP PAN | 239075 | DRIP PAN, 14 GAUGE HOT ROLLED STEEL | 2 |
| CLEAR VINYL DOOR | 242246 | DOORS,CLAY,MOBILE .08X48.00X53.50 WITH SNAPS (FACTORY ASSEMBLED) | 2 |

NOTE:

1.

| | | | | | |
|----------------------------------------------------------------------------------------------------------------------------------------------------------------------------------------------------------------------------------------------------|--|--|--|-------------|------------------|
| ALL DIMENSIONS ARE IN INCHES UNLESS NOTED OTHERWISE DECIMALS: .X = ± .030 .XX = ± .020 .XXX = ± .010 ANGLES: = ± 1° CABINET SQUARENESS: = ± .0625 | | | | DWN BY: EMR | DATE DWN: 3/4/14 |
| CONFIDENTIAL: ALL DESIGN RIGHTS RESERVED THE INFORMATION, DATA, DESIGN, AND DRAWINGS EMBODIED IN THIS DOCUMENT AND ALL REPRODUCTIONS THEREOF ARE THE EXCLUSIVE PROPERTY OF DIVERSIFIED WOODCRAFTS, INC. | | | | APR BY: | DATE APR: |
| THESE DOCUMENTS ARE SUPPLIED WITH THE UNDERSTANDING THAT THEY WILL NOT BE DISCLOSED TO THIRD PARTIES WITHOUT WRITTEN CONSENT OF DIVERSIFIED WOODCRAFTS, INC. ANY REPRODUCTION IN PART OR WHOLE WITHOUT WRITTEN CONSENT IS SUBJECT TO LEGAL ACTION. | | | | APR BY: | DATE APR: |



300 South Krueger Street
Suring, WI 54174
diversifiedwoodcrafts.com

TITLE:
SCULPTURE WARE CART
TOOLS AND ASSEMBLY COMPONENTS

| REV. | DESCRIPTION | DATE | NAME | ECN NO. |
|------|-------------------------------|--------|------|---------|
| A | CREATED ASSEMBLY INSTRUCTIONS | 3/4/14 | EMR | - |

REVISION LEVEL

| | | | |
|---------------------------------|---------------|------------------|--------------------|
| DRAWING NUMBER: 5100M | SCALE: NTS | SHEET: 2 OF 4 | REVISION: REV A |
|---------------------------------|---------------|------------------|--------------------|

ADJUSTABLE
SHELF - TYPICAL

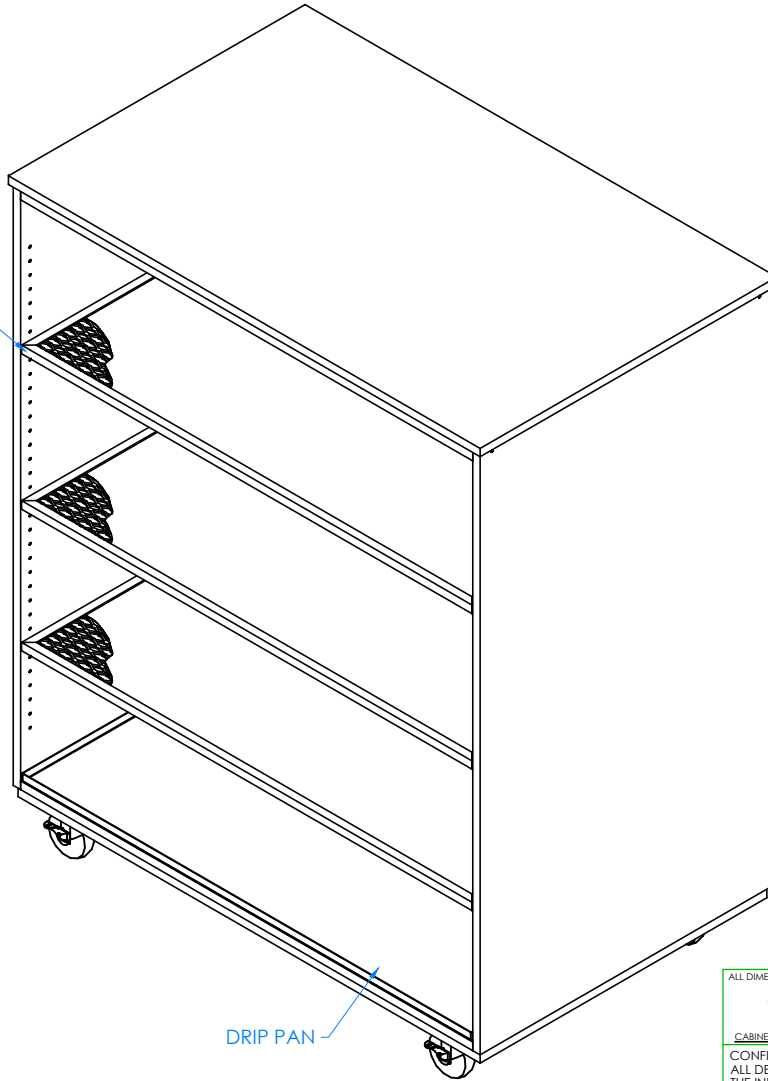

DRIP PAN

NOTE:

1.

STEP 1:

- UNZIP EACH VINYL DOOR AND UNSNAP FROM FRONT OF CABINET.
- INSERT SHELF CLIPS IN THE DESIRED LOCATION.
- PLACE SHELVES ON SHELF CLIPS, MAKING SURE THEY ARE LEVEL.
- PLACE DRIP PAN AT BOTTOM.

| | | | | |
|--------------------------------------------------------|---------|-----|-----------|--------|
| ALL DIMENSIONS ARE IN INCHES UNLESS NOTED OTHERWISE | DWN BY: | EMR | DATE DWN: | 3/4/14 |
| DECIMALS: .X = ± .030 .XX = ± .020 .XXX = ± .010 | APR BY: | | DATE APR: | |
| ANGLES: = ± 1° CABINET SQUARENESS = ± .0625 | APR BY: | | DATE APR: | |

CONFIDENTIAL:
ALL DESIGN RIGHTS RESERVED
THE INFORMATION, DATA, DESIGN, AND DRAWINGS EMBODIED IN THIS DOCUMENT AND ALL REPRODUCTIONS THEREOF ARE THE EXCLUSIVE PROPERTY OF DIVERSIFIED WOODCRAFTS, INC.

THESE DOCUMENTS ARE SUPPLIED WITH THE UNDERSTANDING THAT THEY WILL NOT BE DISCLOSED TO THIRD PARTIES WITHOUT WRITTEN CONSENT OF DIVERSIFIED WOODCRAFTS, INC. ANY REPRODUCTION IN PART OR WHOLE WITHOUT WRITTEN CONSENT IS SUBJECT TO LEGAL ACTION.



300 South Krueger Street
Suring, WI 54174
diversifiedwoodcrafts.com

TITLE:
SCULPTURE WARE CART
ASSEMBLY INSTRUCTIONS

| REV. | DESCRIPTION | DATE | NAME | ECN NO. |
|----------------|-------------------------------|--------|------|---------|
| A | CREATED ASSEMBLY INSTRUCTIONS | 3/4/14 | EMR | - |
| REVISION LEVEL | | | | |

| | | | |
|-----------------|--------|--------|-----------|
| DRAWING NUMBER: | SCALE: | SHEET: | REVISION: |
| 5100M | NTS | 3 OF 4 | REV A |

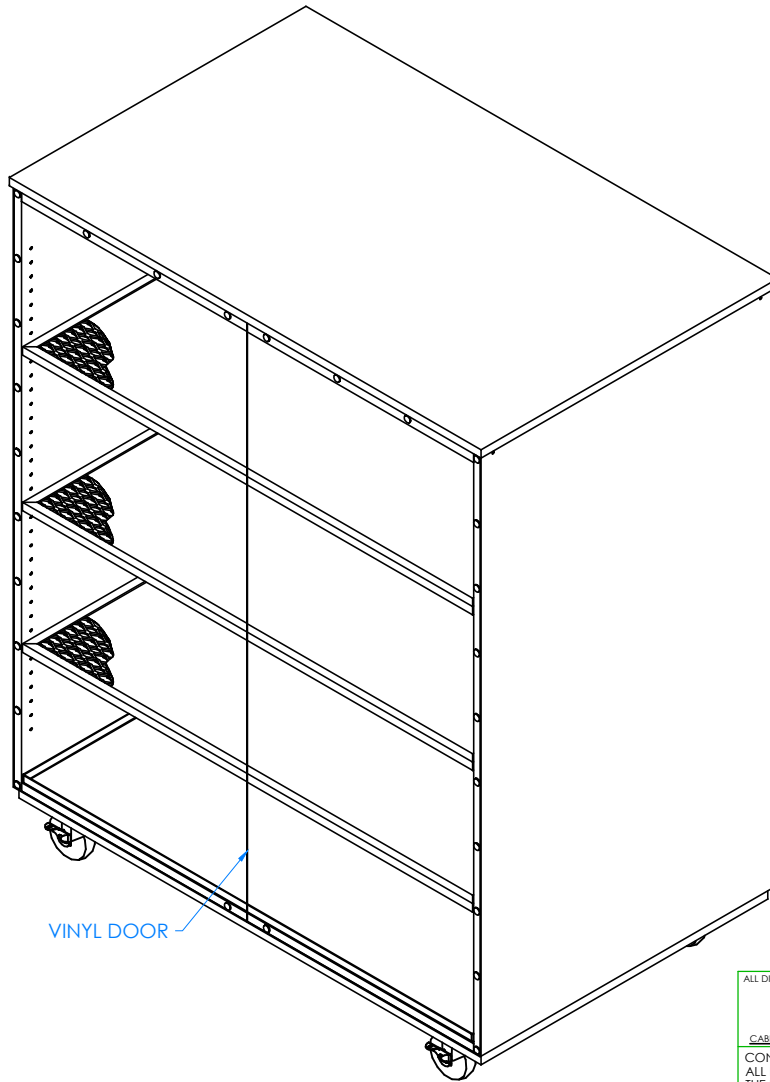

STEP 2:

- SNAP ON THE VINYL DOORS.
- PLACE MOBILE CABINET IN DESIRED LOCATION.

NOTE:

1.

COMPLETE UNIT SHOWN

| | | | | |
|-----------------------------------------------------|---------|-----|-----------|--------|
| ALL DIMENSIONS ARE IN INCHES UNLESS NOTED OTHERWISE | DWN BY: | EMR | DATE DWN: | 3/4/14 |
| DECIMALS: $\frac{1}{16} = \pm .030$ | APR BY: | | DATE APR: | |
| $\frac{1}{8} = \pm .020$ | APR BY: | | DATE APR: | |
| $\frac{1}{4} = \pm .010$ | APR BY: | | DATE APR: | |
| ANGLES: $\pm 1^\circ$ | APR BY: | | DATE APR: | |
| CABINET SQUARENESS: $\pm .0625$ | APR BY: | | DATE APR: | |

CONFIDENTIAL:
ALL DESIGN RIGHTS RESERVED
THE INFORMATION, DATA, DESIGN, AND DRAWINGS EMBODIED IN THIS DOCUMENT AND ALL REPRODUCTIONS THEREOF ARE THE EXCLUSIVE PROPERTY OF DIVERSIFIED WOODCRAFTS, INC.

THESE DOCUMENTS ARE SUPPLIED WITH THE UNDERSTANDING THAT THEY WILL NOT BE DISCLOSED TO THIRD PARTIES WITHOUT WRITTEN CONSENT OF DIVERSIFIED WOODCRAFTS, INC. ANY REPRODUCTION IN PART OR WHOLE WITHOUT WRITTEN CONSENT IS SUBJECT TO LEGAL ACTION.



300 South Krueger Street
Suring, WI 54174
diversifiedwoodcrafts.com

TITLE:
SCULPTURE WARE CART
ASSEMBLY INSTRUCTIONS

| REV. | DESCRIPTION | DATE | NAME | ECN NO. |
|----------------|-------------------------------|--------|------|---------|
| A | CREATED ASSEMBLY INSTRUCTIONS | 3/4/14 | EMR | - |
| REVISION LEVEL | | | | |

| | | | |
|-----------------|--------|--------|-----------|
| DRAWING NUMBER: | SCALE: | SHEET: | REVISION: |
| 5100M | NTS | 4 OF 4 | REV A |