

AUGMENTED REALITY SANDBOX

ARS-4030
ASSEMBLY INSTRUCTIONS

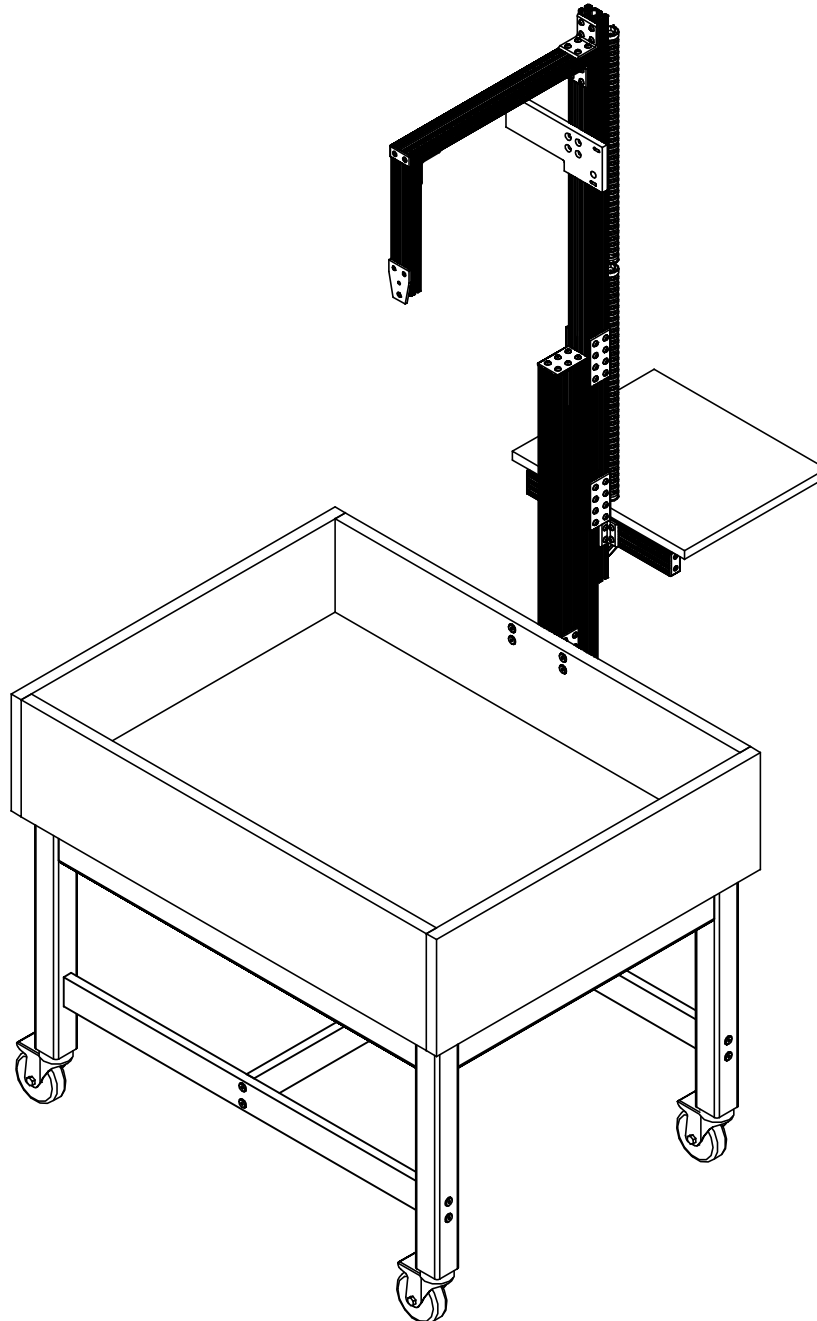

NOTE:

1. MODEL VIEWS MAY NOT REPRESENT EXACT MODEL PURCHASED

| | | | | | |
|---|--|---------|-----|-----------|----------|
| ALL DIMENSIONS ARE IN INCHES UNLESS NOTED OTHERWISE | | DWN BY: | EMR | DATE DWN: | 12/22/16 |
| DECIMALS: X = ± .030 | | APR BY: | | DATE APR: | |
| XX = ± .020 | | APR BY: | | DATE APR: | |
| XXX = ± .010 | | APR BY: | | DATE APR: | |
| ANGLES: ± 1° | | APR BY: | | DATE APR: | |
| CABINET SQUARENESS: ± .0625 | | APR BY: | | DATE APR: | |

CONFIDENTIAL:
ALL DESIGN RIGHTS RESERVED
THE INFORMATION, DATA, DESIGN, AND DRAWINGS EMBODIED IN THIS DOCUMENT AND ALL REPRODUCTIONS THEREOF ARE THE EXCLUSIVE PROPERTY OF DIVERSIFIED WOODCRAFTS, INC.

THESE DOCUMENTS ARE SUPPLIED WITH THE UNDERSTANDING THAT THEY WILL NOT BE DISCLOSED TO THIRD PARTIES WITHOUT WRITTEN CONSENT OF DIVERSIFIED WOODCRAFTS, INC. ANY REPRODUCTION IN PART OR WHOLE WITHOUT WRITTEN CONSENT IS SUBJECT TO LEGAL ACTION.



300 South Krueger Street
Suring, WI 54174
diversifiedwoodcrafts.com

TITLE:
AUGMENTED REALITY SANDBOX
ASSEMBLY INSTRUCTIONS

| REV. | CREATED DRAWING | X/X/X | XYZ | N/A |
|----------------|-----------------|-------|------|---------|
| | DESCRIPTION | DATE | NAME | ECN No. |
| REVISION LEVEL | | | | |

| | | | |
|-----------------|--------|---------|-----------|
| DRAWING NUMBER: | SCALE: | SHEET: | REVISION: |
| ARS-4030 | NTS | 1 OF 19 | REV A |

PALLET CONTENTS

| ITEMS INCLUDED | PART # | PART DESCRIPTION | QTY |
|--------------------------|----------|--|-----|
| SANDBOX ASSEMBLY | N/A | SANDBOX ASSEMBLY (FACTORY ASSEMBLED) | 1 |
| APRON ASSEMBLY | N/A | APRON ASSEMBLY (FACTORY ASSEMBLED) | 1 |
| ALUMINUM EXTRUSION KIT | 252933 | ARS-4030 HARDWARE KIT, PRICE ENGINEERING | 1 |
| STRETCHER | N/A | STRETCHER - 0.75"THK X 2.50"W X 26.88"L | 1 |
| BRACE | N/A | BRACE - 0.75"THK X 2.50"W X 35.38"L | 2 |
| LAPTOP SHELF | N/A | LAPTOP SHELF - 0.75"THK X 14.00"W X 17.00"L | 1 |
| *LEGS* - SEE NOTE 1 | N/A | LEG,2.25X2.25X28.25 | 4 |
| *WASHERS* - SEE NOTE 1 | 100039 | WASHER,SPLIT LOCK 5/16 | 4 |
| *HEX NUTS* - SEE NOTE 1 | 100044 | NUT,HEX 5/16-18 STEEL ZINC | 4 |
| *CASTERS* - SEE NOTE 1 | 255721 | CASTER,4",TOTAL LOCK STEM CASTER M12 - 1.75MM X 1.5" | 4 |
| *CONFIRMATS - STRETCHER* | 228564 | SCREW,7MMX50MM,CONN,ALLENHEAD,BLACK | 4 |
| *CONFIRMATS - BRACE* | 227578 | SCREW,7MMX90MM,CONN,ALLENHEAD,BLACK | 8 |
| LAPTOP | 257897 | LAPTOP,ACER NITRO 5,MODEL:AN515-55-53E5, NH.QB0AA.001-WINDOWS 10 | 1 |
| CAMERA/SENSOR BAR | 257910-U | KINECT V2 CAMERA-REFURBISHED MODELS | 1 |
| PROJECTOR | 252555 | BENQ 9H.JE177.13A MX631ST PROJECTOR | 1 |
| HARDWARE BOX | N/A | MISC ITEMS - SEE NEXT PAGE FOR CONTENTS | 1 |

NOTE:

- LEGS, WASHERS, HEX NUTS & CASTERS ARE BOXED TOGETHER.

| | | |
|---|-----------------------------------|--|
| ALL DIMENSIONS ARE IN INCHES UNLESS NOTED OTHERWISE DECIMALS: X = ± .030 XX = ± .020 XXX = ± .010 ANGLES: ± 1° CABINET SQUARENESS: ± .0625 | DWN BY: EMR APR BY: APR BY: | DATE DWN: 12/22/16 DATE APR: DATE APR: |
|---|-----------------------------------|--|



300 South Krueger Street
Suring, WI 54174
diversifiedwoodcrafts.com

CONFIDENTIAL:
ALL DESIGN RIGHTS RESERVED
THE INFORMATION, DATA, DESIGN, AND DRAWINGS EMBODIED IN THIS DOCUMENT AND ALL REPRODUCTIONS THEREOF ARE THE EXCLUSIVE PROPERTY OF DIVERSIFIED WOODCRAFTS, INC.

TITLE:
**AUGMENTED REALITY SANDBOX
PALLET CONTENTS**

| | | | |
|------------------------------------|---------------|-------------------|--------------------|
| DRAWING NUMBER: ARS-4030 | SCALE: NTS | SHEET: 2 OF 19 | REVISION: REV A |
|------------------------------------|---------------|-------------------|--------------------|

| REV. | DESCRIPTION | DATE | NAME | ECN NO. |
|----------------|-----------------|----------|------|---------|
| A | CREATED DRAWING | 12/22/16 | EMR | - |
| REVISION LEVEL | | | | |

THESE DOCUMENTS ARE SUPPLIED WITH THE UNDERSTANDING THAT THEY WILL NOT BE DISCLOSED TO THIRD PARTIES WITHOUT WRITTEN CONSENT OF DIVERSIFIED WOODCRAFTS, INC. ANY REPRODUCTION IN PART OR WHOLE WITHOUT WRITTEN CONSENT IS SUBJECT TO LEGAL ACTION.

HARDWARE BOX PACKING LIST

| ITEMS INCLUDED | PART # | PART DESCRIPTION | QTY | PACKED |
|--|------------------|--|-----|--------|
| PROJECTOR MOUNTING BLOCK | 252793 OR 255571 | PROJECTOR MOUNTING BLOCK - 0.50"THK X 3.875"W X 9.50"L | 1 | |
| MOUNTING BLOCK FOR 2"X4" ALUMINUM UPRIGHT | 252983 | MOUNT BLOCK,1.75" X 2.25" X 7.00" | 1 | |
| SCREWS - APRON ASSEMBLY TO SANDBOX ASSEMBLY | 100641 | SCREW,#8X1-3/4 QUAD RD WASH HD | 14 | |
| CONFIRMATS - MOUNTING CLEAT | 252459 | SCREW,1/4-20X60MM,CONN, ALLENHEAD,BLACK | 4 | |
| CONFIRMATS - SANDBOX | 252460 | SCREW,1/4-20X20MM,CON,ALLENHEAD,BLK | 4 | |
| JOINT CONNECTING NUT - MOUNTING CLEAT & SANDBOX | 234337-JCN | JOINT CONNECTING NUT, 1/4-20X17MM | 8 | |
| CABLE ADAPTER | 257960 | HDE POWER SUPPLY AC CABLE ADAPTER FOR XBOX KINECT V2 MOTION SENSOR | 1 | |
| HDMI CABLE | 252579 | CABLE,HDMI, 6 FEET | 1 | |
| SCREWS FOR CAMERA MOUNT | 252718 | SCREW,#10-32X5/8" PHILLIPS FLAT HEAD MACHINE SCREW | 2 | |
| SCREWS FOR PROJECTOR BRACKET | 252720 | SCREW,1/4"-20X3/4" PHILLIPS FLAT HEAD MACHINE SCREW | 4 | |
| SCREWS FOR PROJECTOR | 252719 | SCREW,M4-0.7X20MM PHILLIPS PAN HEAD MACHINE SCREW | 3 | |
| DROP LEAF SUPPORT FOR LAPTOP SHELF | 100028 | SUPPORT,DROP LEAF 497840-1956 | 1 | |
| SCREWS FOR DROP LEAF SUPPORT AND ALUMINUM HINGES | 100111 | SCREW,5/8 TRUSS HEAD | 6 | |
| SCREW FOR MOUNTING KINECT TO CAMERA MOUNTING PLATE | 257893 | SCREW,1/4-20 X .500",ZINC-PLATED STEEP PHILLIPS FLAT HEAD SCREWS | 1 | |

| TOOLS REQUIRED |
|--|
| 1/2" WRENCH |
| 1/2" SOCKET AND TORQUE WRENCH - OPTIONAL |
| 4MM ALLEN WRENCH (FOR CONFIRMATS) |
| 5MM ALLEN WRENCH (FOR JCN) |
| 5/32" ALLEN WRENCH (FOR 1/4"-20x1/2" SCREWS) |
| 1/8" ALLEN WRENCH (FOR #10-32x3/8" SCREWS) |
| PHILLIPS SCREWDRIVER |

| LAPTOP/PROJECTOR COMPONENTS |
|--|
| QTY (1) - KINECT V2 CAMERA (P# 257910-U) |
| QTY (1) - DIGITAL PROJECTOR (P# 252555) |
| QTY (1) - ACER LAPTOP (P# 257897) |
| QTY (1) - FLASH DRIVE W/ SET UP INSTRUCTIONS (P# 257896) |

NOTE:

1.

| | | | | | |
|--|-------------|--------------------|--|--|--|
| ALL DIMENSIONS ARE IN INCHES UNLESS NOTED OTHERWISE DECIMALS: X = ± .030 XX = ± .020 XXX = ± .010 ANGLES: ± 1° CABINET SQUARENESS: ± .0625 | DWN BY: EMR | DATE DWN: 12/22/16 | | | |
| CONFIDENTIAL: ALL DESIGN RIGHTS RESERVED THE INFORMATION, DATA, DESIGN, AND DRAWINGS EMBODIED IN THIS DOCUMENT AND ALL REPRODUCTIONS THEREOF ARE THE EXCLUSIVE PROPERTY OF DIVERSIFIED WOODCRAFTS, INC. | APR BY: | DATE APR: | | | |
| THESE DOCUMENTS ARE SUPPLIED WITH THE UNDERSTANDING THAT THEY WILL NOT BE DISCLOSED TO THIRD PARTIES WITHOUT WRITTEN CONSENT OF DIVERSIFIED WOODCRAFTS, INC. ANY REPRODUCTION IN PART OR WHOLE WITHOUT WRITTEN CONSENT IS SUBJECT TO LEGAL ACTION. | APR BY: | DATE APR: | | | |



300 South Krueger Street
Suring, WI 54174
diversifiedwoodcrafts.com

| | | | |
|---|---------------|-------------------|--------------------|
| TITLE: AUGMENTED REALITY SANDBOX HARDWARE BOX PACKING LIST & TOOLS REQUIRED | | | |
| DRAWING NUMBER: ARS-4030 | SCALE: NTS | SHEET: 3 OF 19 | REVISION: REV A |

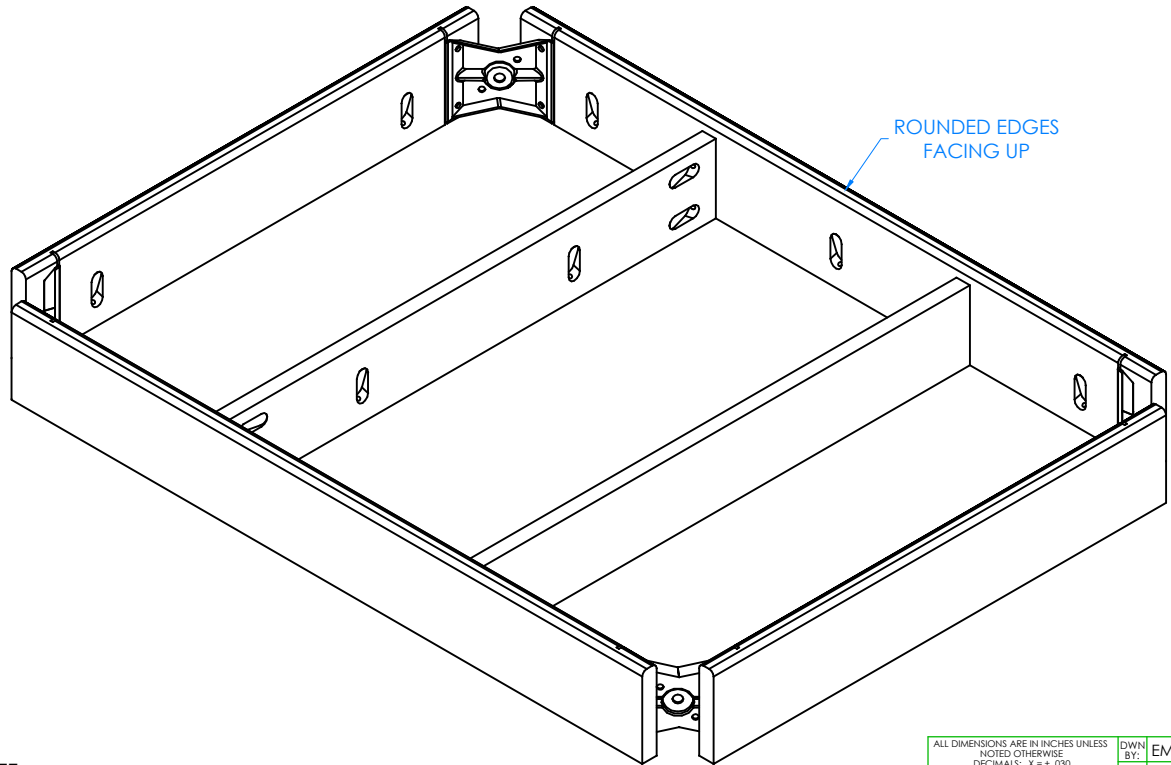

STEP 1:

- LAY APRON ASSEMBLY ON FLOOR WITH ROUNDED EDGES FACING UP.

NOTE:

1.

| | | | | |
|---|---------|-----|-----------|----------|
| ALL DIMENSIONS ARE IN INCHES UNLESS NOTED OTHERWISE | DWN BY: | EMR | DATE DWN: | 12/22/16 |
| DECIMALS: X = ± .000 | APR BY: | | DATE APR: | |
| XX = ± .020 | APR BY: | | DATE APR: | |
| XXX = ± .010 | APR BY: | | DATE APR: | |
| ANGLES: = ± 1° | APR BY: | | DATE APR: | |
| CABINET SQUARENESS: = ± .0625 | APR BY: | | DATE APR: | |

CONFIDENTIAL:
 ALL DESIGN RIGHTS RESERVED
 THE INFORMATION, DATA, DESIGN, AND DRAWINGS EMBODIED IN THIS DOCUMENT AND ALL REPRODUCTIONS THEREOF ARE THE EXCLUSIVE PROPERTY OF DIVERSIFIED WOODCRAFTS, INC.

THESE DOCUMENTS ARE SUPPLIED WITH THE UNDERSTANDING THAT THEY WILL NOT BE DISCLOSED TO THIRD PARTIES WITHOUT WRITTEN CONSENT OF DIVERSIFIED WOODCRAFTS, INC. ANY REPRODUCTION IN PART OR WHOLE WITHOUT WRITTEN CONSENT IS SUBJECT TO LEGAL ACTION.



300 South Krueger Street
 Suring, WI 54174
 diversifiedwoodcrafts.com

TITLE:
 AUGMENTED REALITY SANDBOX
 ASSEMBLY INSTRUCTIONS

| A | CREATED DRAWING | 12/22/16 | EMR | - |
|----------------|-----------------|----------|------|---------|
| REV. | DESCRIPTION | DATE | NAME | ECN NO. |
| REVISION LEVEL | | | | |

| | | | | | | | |
|-----------------|----------|--------|-----|--------|---------|-----------|-------|
| DRAWING NUMBER: | ARS-4030 | SCALE: | NTS | SHEET: | 4 OF 19 | REVISION: | REV A |
|-----------------|----------|--------|-----|--------|---------|-----------|-------|

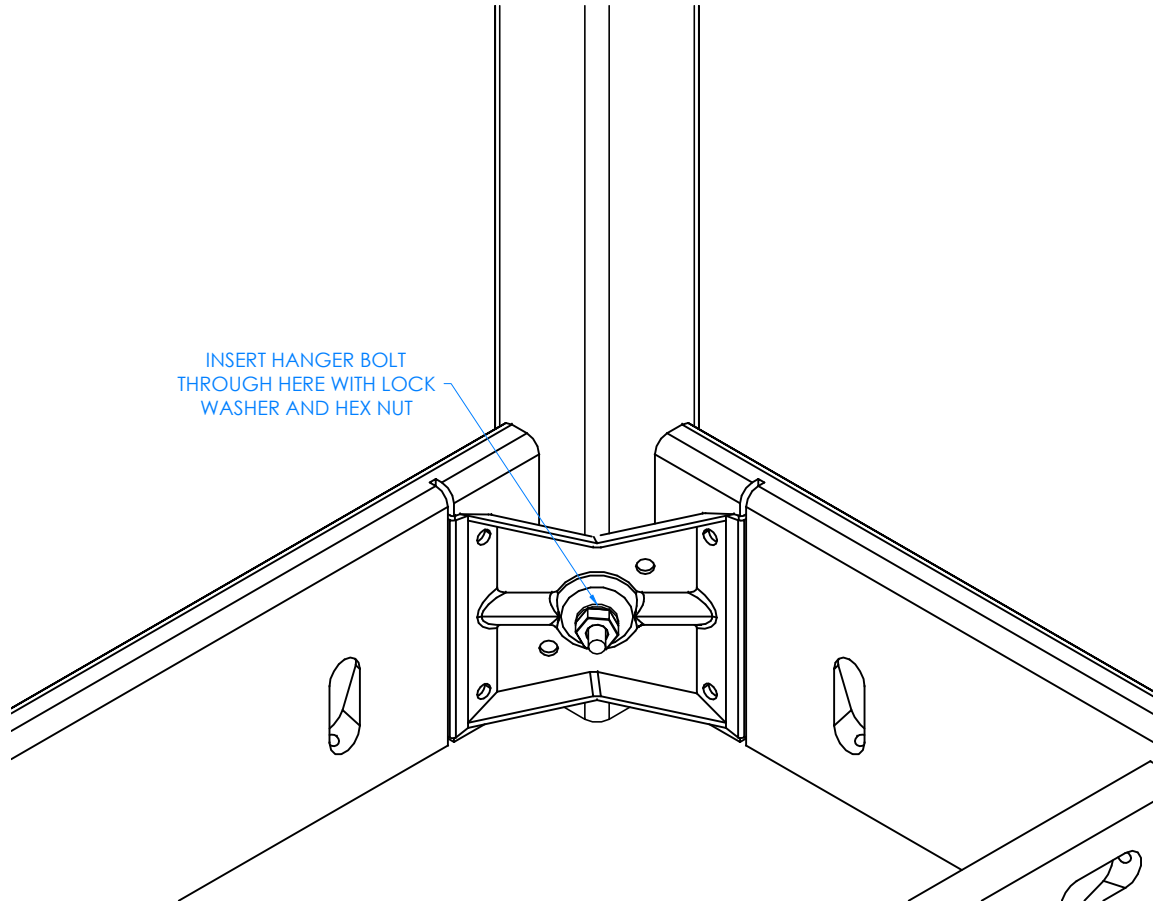

INSERT HANGER BOLT THROUGH HERE WITH LOCK WASHER AND HEX NUT

CLOSE UP OF CORNER LEG ASSEMBLY

STEP 2:

- INSERT HANGER BOLT ON ONE LEG THROUGH THE CORNER BRACKET.
- MAKE SURE THRU HOLES ON LEGS RUN PARALLEL TO THE LONG APRONS (SEE STEP 3 FOR CLOSE UP).
- INSERT LOCK WASHER AND HEX NUT.
- SCREW ON NUT USING A 1/2" WRENCH OR 1/2" SOCKET AND TORQUE WRENCH.
- DO NOT TIGHTEN ALL THE WAY.
- REPEAT FOR OTHER LEGS.

NOTE:

1.

| | | | | |
|---|---------|-----|-----------|----------|
| ALL DIMENSIONS ARE IN INCHES UNLESS NOTED OTHERWISE | DWN BY: | EMR | DATE DWN: | 12/22/16 |
| DECIMALS: X = ± .000 | APR BY: | | DATE APR: | |
| XX = ± .020 | APR BY: | | DATE APR: | |
| XXX = ± .010 | APR BY: | | DATE APR: | |
| ANGLES: = ± 1° | APR BY: | | DATE APR: | |
| CABINET SQUARENESS: = ± .0625 | APR BY: | | DATE APR: | |

CONFIDENTIAL:
ALL DESIGN RIGHTS RESERVED
THE INFORMATION, DATA, DESIGN, AND DRAWINGS EMBODIED IN THIS DOCUMENT AND ALL REPRODUCTIONS THEREOF ARE THE EXCLUSIVE PROPERTY OF DIVERSIFIED WOODCRAFTS, INC.

THESE DOCUMENTS ARE SUPPLIED WITH THE UNDERSTANDING THAT THEY WILL NOT BE DISCLOSED TO THIRD PARTIES WITHOUT WRITTEN CONSENT OF DIVERSIFIED WOODCRAFTS, INC. ANY REPRODUCTION IN PART OR WHOLE WITHOUT WRITTEN CONSENT IS SUBJECT TO LEGAL ACTION.



300 South Krueger Street
Suring, WI 54174
diversifiedwoodcrafts.com

TITLE:
AUGMENTED REALITY SANDBOX
ASSEMBLY INSTRUCTIONS

| REV. | DESCRIPTION | DATE | NAME | ECN NO. |
|------|-----------------|----------|------|---------|
| A | CREATED DRAWING | 12/22/16 | EMR | - |

REVISION LEVEL

| | | | |
|-----------------|--------|---------|-----------|
| DRAWING NUMBER: | SCALE: | SHEET: | REVISION: |
| ARS-4030 | NTS | 5 OF 19 | REV A |

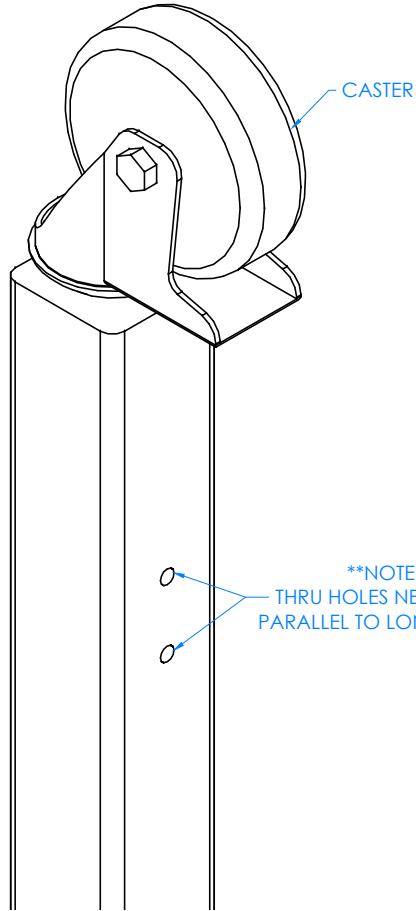

STEP 3:

- ATTACH CASTERS TO BOTTOM OF LEGS.

CLOSE UP OF CASTER ASSEMBLY

NOTE:

- 1.

| | | | | |
|---|---------|-----|-----------|----------|
| ALL DIMENSIONS ARE IN INCHES UNLESS NOTED OTHERWISE | DWN BY: | EMR | DATE DWN: | 12/22/16 |
| DECIMALS: $X = \pm .000$ | APR BY: | | DATE APR: | |
| $XX = \pm .020$ | APR BY: | | DATE APR: | |
| $XXX = \pm .010$ | APR BY: | | DATE APR: | |
| ANGLES: $= \pm 1^{\circ}0'$ | APR BY: | | DATE APR: | |
| CABINET SQUARENESS: $= \pm .0625$ | APR BY: | | DATE APR: | |

CONFIDENTIAL:
 ALL DESIGN RIGHTS RESERVED
 THE INFORMATION, DATA, DESIGN, AND DRAWINGS EMBODIED IN THIS DOCUMENT AND ALL REPRODUCTIONS THEREOF ARE THE EXCLUSIVE PROPERTY OF DIVERSIFIED WOODCRAFTS, INC.

THESE DOCUMENTS ARE SUPPLIED WITH THE UNDERSTANDING THAT THEY WILL NOT BE DISCLOSED TO THIRD PARTIES WITHOUT WRITTEN CONSENT OF DIVERSIFIED WOODCRAFTS, INC. ANY REPRODUCTION IN PART OR WHOLE WITHOUT WRITTEN CONSENT IS SUBJECT TO LEGAL ACTION.



300 South Krueger Street
 Suring, WI 54174
 diversifiedwoodcrafts.com

TITLE:
 AUGMENTED REALITY SANDBOX
 ASSEMBLY INSTRUCTIONS

| REV. | DESCRIPTION | DATE | NAME | ECN NO. |
|----------------|-----------------|----------|------|---------|
| A | CREATED DRAWING | 12/22/16 | EMR | - |
| REVISION LEVEL | | | | |

| | | | |
|-----------------|--------|---------|-----------|
| DRAWING NUMBER: | SCALE: | SHEET: | REVISION: |
| ARS-4030 | NTS | 6 OF 19 | REV A |

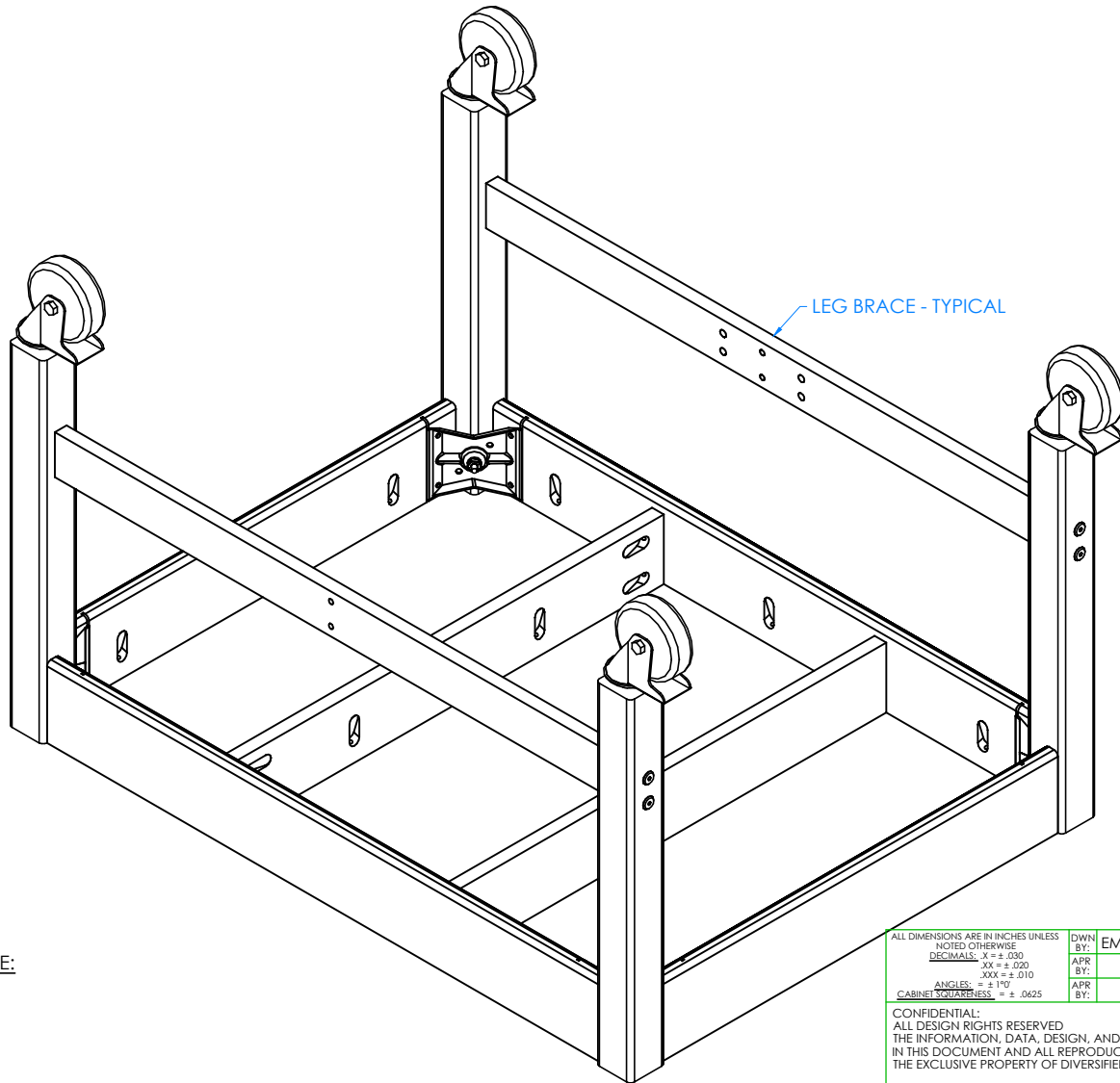

STEP 4:

- ATTACH BRACES TO LEGS.
- INSERT THE CONFIRMATS INTO ONE LEG AND SCREW INTO BRACE.
- REPEAT ON OTHER LEGS.
- MAKE SURE BRACES ARE STRAIGHT AND ALL CONFIRMATS ARE TIGHT.

NOTE:

1.

| | | | | |
|---|---------|-----|-----------|----------|
| ALL DIMENSIONS ARE IN INCHES UNLESS NOTED OTHERWISE | DWN BY: | EMR | DATE DWN: | 12/22/16 |
| DECIMALS: X = ± .000 | APR BY: | | DATE APR: | |
| XX = ± .020 | APR BY: | | DATE APR: | |
| XXX = ± .010 | APR BY: | | DATE APR: | |
| ANGLES: = ± 1° | APR BY: | | DATE APR: | |
| CABINET SQUARENESS: = ± .0625 | APR BY: | | DATE APR: | |

CONFIDENTIAL:
 ALL DESIGN RIGHTS RESERVED
 THE INFORMATION, DATA, DESIGN, AND DRAWINGS EMBODIED IN THIS DOCUMENT AND ALL REPRODUCTIONS THEREOF ARE THE EXCLUSIVE PROPERTY OF DIVERSIFIED WOODCRAFTS, INC.

THESE DOCUMENTS ARE SUPPLIED WITH THE UNDERSTANDING THAT THEY WILL NOT BE DISCLOSED TO THIRD PARTIES WITHOUT WRITTEN CONSENT OF DIVERSIFIED WOODCRAFTS, INC. ANY REPRODUCTION IN PART OR WHOLE WITHOUT WRITTEN CONSENT IS SUBJECT TO LEGAL ACTION.



300 South Krueger Street
 Suring, WI 54174
 diversifiedwoodcrafts.com

TITLE:
**AUGMENTED REALITY SANDBOX
 ASSEMBLY INSTRUCTIONS**

| A | CREATED DRAWING | 12/22/16 | EMR | - |
|----------------|-----------------|----------|------|---------|
| REV. | DESCRIPTION | DATE | NAME | ECN NO. |
| REVISION LEVEL | | | | |

| | | | | | | | |
|-----------------|----------|--------|-----|--------|---------|-----------|-------|
| DRAWING NUMBER: | ARS-4030 | SCALE: | NTS | SHEET: | 7 OF 19 | REVISION: | REV A |
|-----------------|----------|--------|-----|--------|---------|-----------|-------|

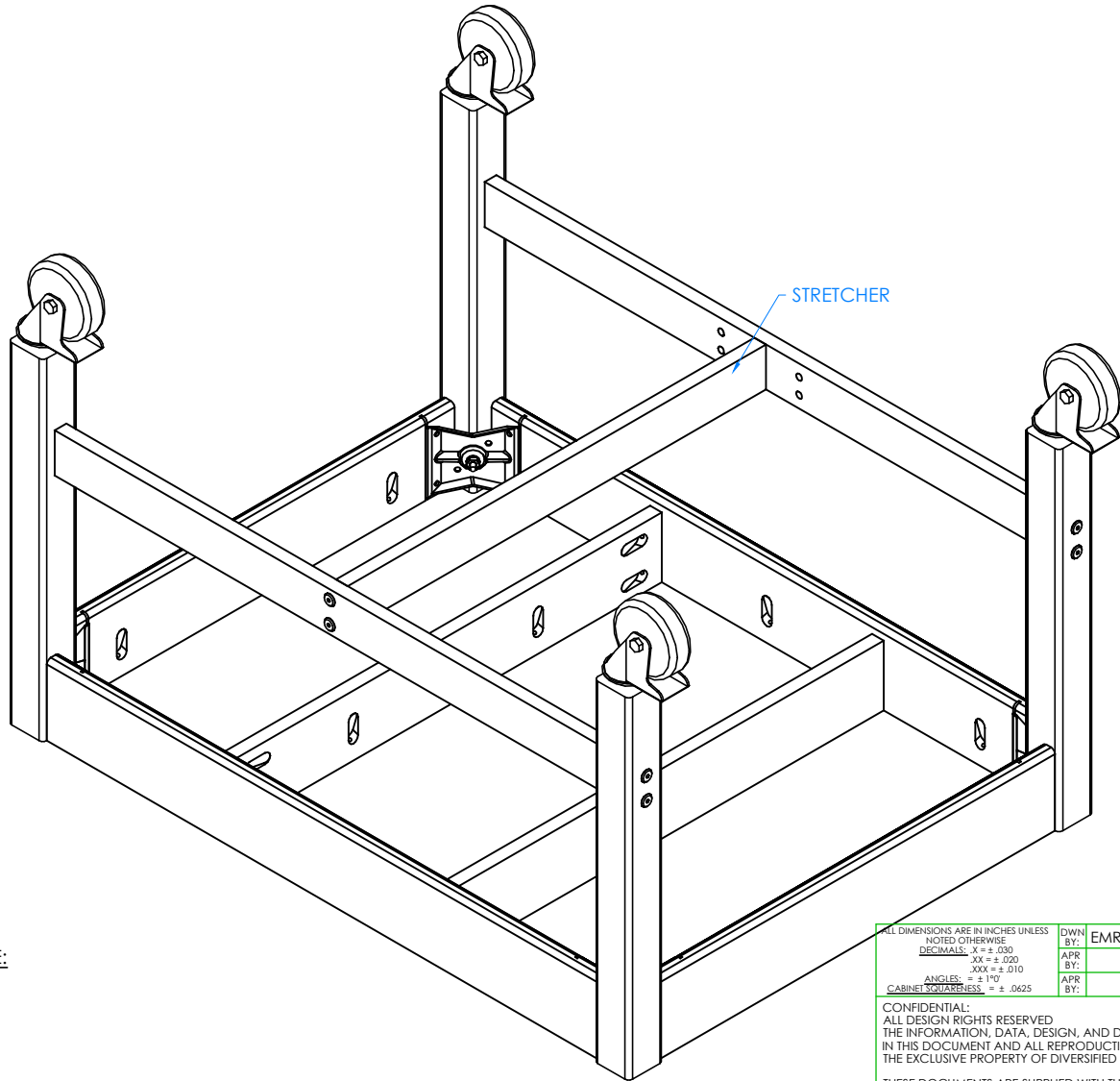

STEP 5:

- INSERT STRETCHER TO CENTER OF BRACES.
- ATTACH STRETCH WITH HARDWARE PROVIDED.
- GO BACK TO STEP 2 AND TIGHTEN UP THE HANGER BOLTS FOR EACH LEG USING A 1/2" WRENCH OR 1/2" SOCKET AND TORQUE WRENCH, TO A MINIMUM OF 12FT LBS BUT NOT TO EXCEED 17FT LBS.

NOTE:

1.

| | | | |
|---|--------------|-----------|----------|
| ALL DIMENSIONS ARE IN INCHES UNLESS NOTED OTHERWISE | | | |
| DECIMALS: | X = ± .000 | DWN BY: | EMR |
| | XX = ± .020 | DATE DWN: | 12/22/16 |
| | XXX = ± .010 | APR BY: | |
| ANGLES: | = ± 1° | DATE APR: | |
| CABINET SQUARENESS: | = ± .0625 | APR BY: | |

CONFIDENTIAL:
 ALL DESIGN RIGHTS RESERVED
 THE INFORMATION, DATA, DESIGN, AND DRAWINGS EMBODIED IN THIS DOCUMENT AND ALL REPRODUCTIONS THEREOF ARE THE EXCLUSIVE PROPERTY OF DIVERSIFIED WOODCRAFTS, INC.

THESE DOCUMENTS ARE SUPPLIED WITH THE UNDERSTANDING THAT THEY WILL NOT BE DISCLOSED TO THIRD PARTIES WITHOUT WRITTEN CONSENT OF DIVERSIFIED WOODCRAFTS, INC. ANY REPRODUCTION IN PART OR WHOLE WITHOUT WRITTEN CONSENT IS SUBJECT TO LEGAL ACTION.



300 South Krueger Street
 Suring, WI 54174
 diversifiedwoodcrafts.com

TITLE:
 AUGMENTED REALITY SANDBOX
 ASSEMBLY INSTRUCTIONS

| A | CREATED DRAWING | 12/22/16 | EMR | - |
|----------------|-----------------|----------|------|---------|
| REV. | DESCRIPTION | DATE | NAME | ECN NO. |
| REVISION LEVEL | | | | |

| | | | | | | | |
|-----------------|----------|--------|-----|--------|---------|-----------|-------|
| DRAWING NUMBER: | ARS-4030 | SCALE: | NTS | SHEET: | 8 OF 19 | REVISION: | REV A |
|-----------------|----------|--------|-----|--------|---------|-----------|-------|

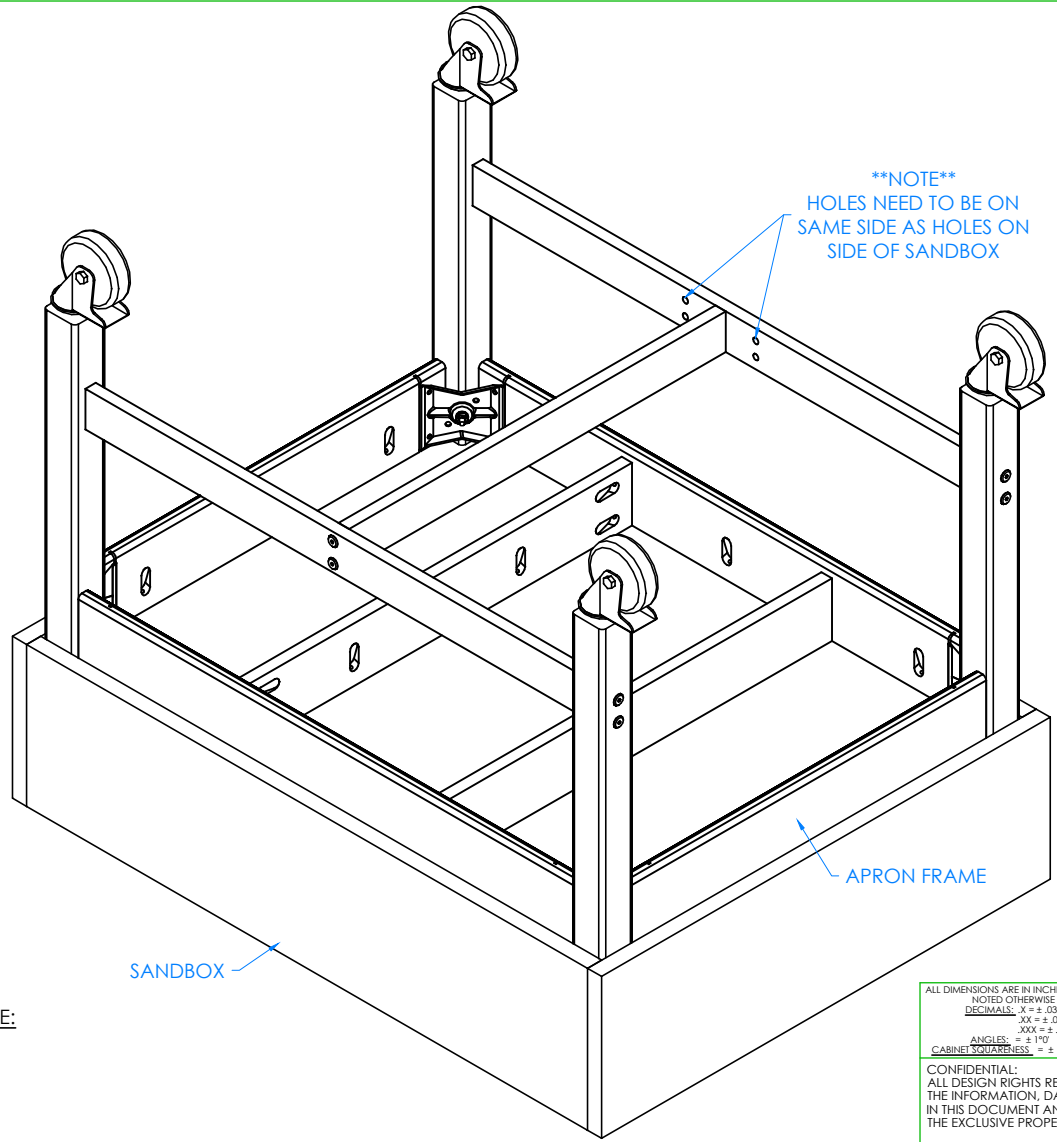

****NOTE****
 HOLES NEED TO BE ON
 SAME SIDE AS HOLES ON
 SIDE OF SANDBOX

STEP 6:

- SET APRON FRAME ON TOP OF SANDBOX AND ATTACH TO SANDBOX WITH THE 14 - #8X1-3/4 QUAD RD WASH HD SCREWS PROVIDED.
- MAKE SURE THE 4 HOLES ON BRACES ARE ON SAME SIDE AS THE 4 HOLES ON SANDBOX (SEE PHOTO IN STEP 6).

NOTE:
 1.

| | | | | |
|---|---------|-----|-----------|----------|
| ALL DIMENSIONS ARE IN INCHES UNLESS NOTED OTHERWISE | DWN BY: | EMR | DATE DWN: | 12/22/16 |
| DECIMALS: X = ± .000 | APR BY: | | DATE APR: | |
| XX = ± .020 | APR BY: | | DATE APR: | |
| XXX = ± .010 | APR BY: | | DATE APR: | |
| ANGLES: = ± 1° | APR BY: | | DATE APR: | |
| CABINET SQUARENESS: = ± .0625 | APR BY: | | DATE APR: | |

CONFIDENTIAL:
 ALL DESIGN RIGHTS RESERVED
 THE INFORMATION, DATA, DESIGN, AND DRAWINGS EMBODIED IN THIS DOCUMENT AND ALL REPRODUCTIONS THEREOF ARE THE EXCLUSIVE PROPERTY OF DIVERSIFIED WOODCRAFTS, INC.

THESE DOCUMENTS ARE SUPPLIED WITH THE UNDERSTANDING THAT THEY WILL NOT BE DISCLOSED TO THIRD PARTIES WITHOUT WRITTEN CONSENT OF DIVERSIFIED WOODCRAFTS, INC. ANY REPRODUCTION IN PART OR WHOLE WITHOUT WRITTEN CONSENT IS SUBJECT TO LEGAL ACTION.



300 South Krueger Street
 Suring, WI 54174
 diversifiedwoodcrafts.com

TITLE:
**AUGMENTED REALITY SANDBOX
 ASSEMBLY INSTRUCTIONS**

| A | CREATED DRAWING | 12/22/16 | EMR | - |
|----------------|-----------------|----------|------|---------|
| REV. | DESCRIPTION | DATE | NAME | ECN NO. |
| REVISION LEVEL | | | | |

| | | | | | | | |
|-----------------|----------|--------|-----|--------|---------|-----------|-------|
| DRAWING NUMBER: | ARS-4030 | SCALE: | NTS | SHEET: | 9 OF 19 | REVISION: | REV A |
|-----------------|----------|--------|-----|--------|---------|-----------|-------|

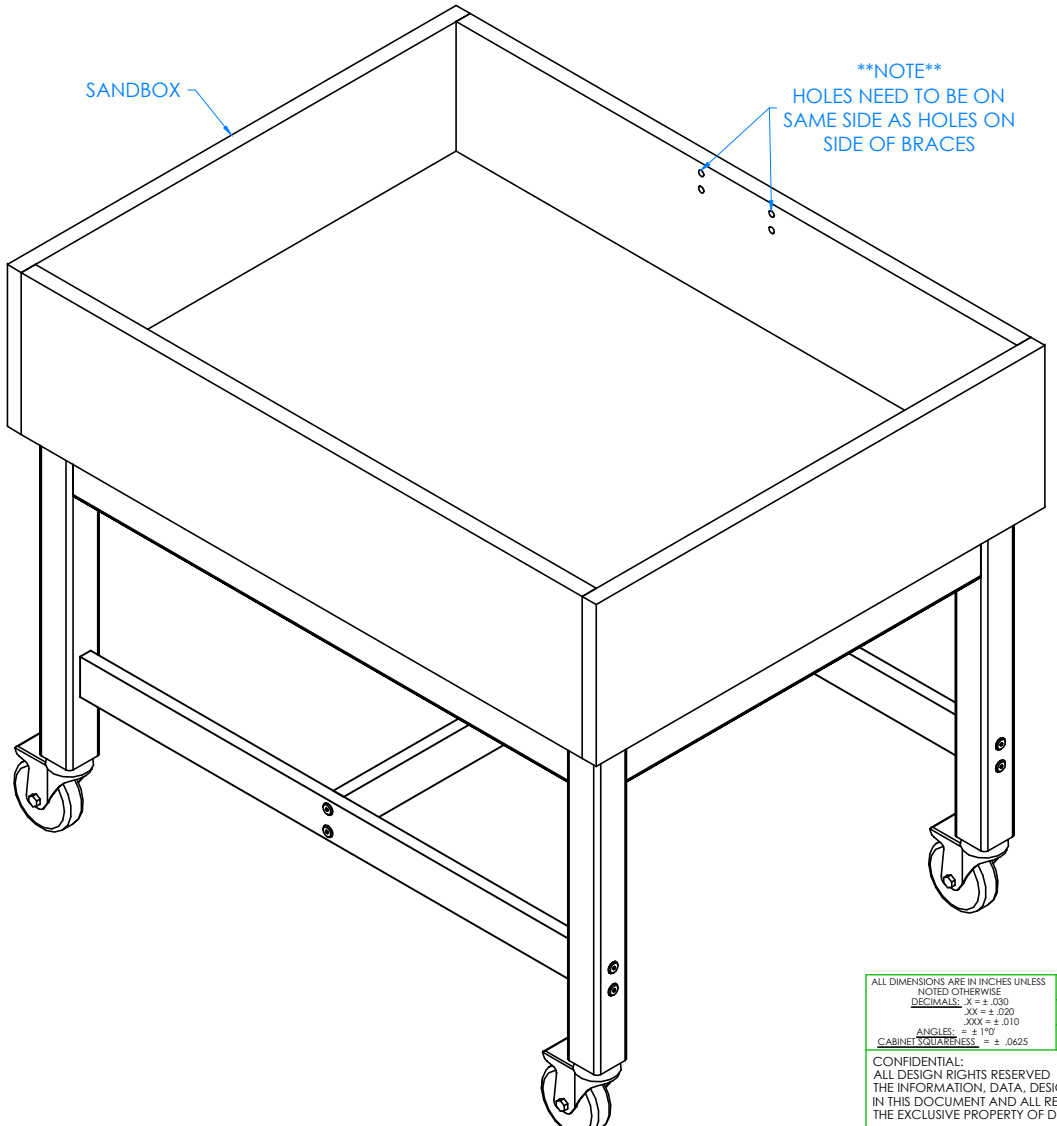

NOTE:
1.

STEP 7:

- WITH HELP FROM ANOTHER PERSON, TURN UNIT OVER SO SANDBOX IS FACING UP.

| | | | |
|---|--------------|-----------|----------|
| ALL DIMENSIONS ARE IN INCHES UNLESS NOTED OTHERWISE | | | |
| DECIMALS: | X = ± .000 | DWN BY: | EMR |
| | XX = ± .020 | DATE DWN: | 12/22/16 |
| | XXX = ± .010 | APR BY: | |
| ANGLES: | = ± 1° | DATE APR: | |
| CABINET SQUARENESS: | = ± .0625 | APR BY: | |

CONFIDENTIAL:
ALL DESIGN RIGHTS RESERVED
THE INFORMATION, DATA, DESIGN, AND DRAWINGS EMBODIED IN THIS DOCUMENT AND ALL REPRODUCTIONS THEREOF ARE THE EXCLUSIVE PROPERTY OF DIVERSIFIED WOODCRAFTS, INC.

THESE DOCUMENTS ARE SUPPLIED WITH THE UNDERSTANDING THAT THEY WILL NOT BE DISCLOSED TO THIRD PARTIES WITHOUT WRITTEN CONSENT OF DIVERSIFIED WOODCRAFTS, INC. ANY REPRODUCTION IN PART OR WHOLE WITHOUT WRITTEN CONSENT IS SUBJECT TO LEGAL ACTION.



300 South Krueger Street
Suring, WI 54174
diversifiedwoodcrafts.com

TITLE:
AUGMENTED REALITY SANDBOX
ASSEMBLY INSTRUCTIONS

| REV. | DESCRIPTION | DATE | NAME | ECN NO. |
|------|-----------------|----------|------|---------|
| A | CREATED DRAWING | 12/22/16 | EMR | - |

| | | | | | | | |
|-----------------|----------|--------|-----|--------|----------|-----------|-------|
| DRAWING NUMBER: | ARS-4030 | SCALE: | NTS | SHEET: | 10 OF 19 | REVISION: | REV A |
|-----------------|----------|--------|-----|--------|----------|-----------|-------|

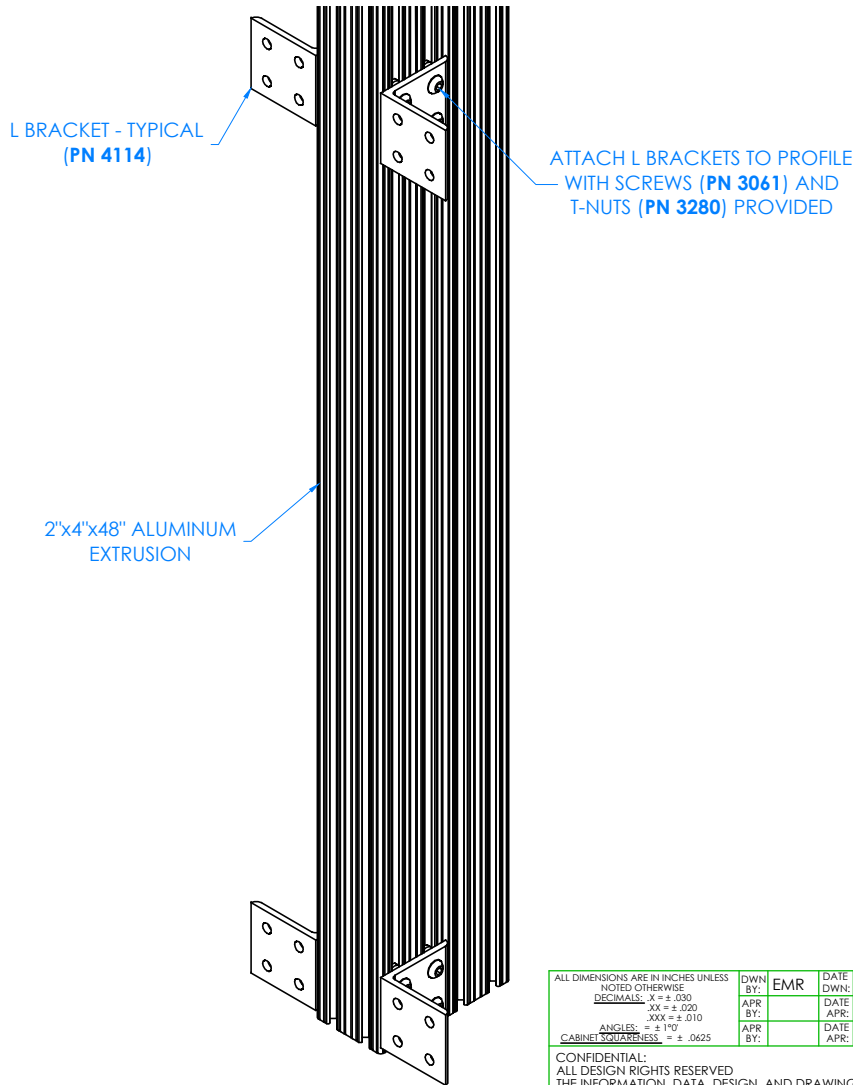

CLOSE UP OF ALUMINUM EXTRUSION WITH L BRACKETS ATTACHED

STEP 8:

- SLIDE (2) L-BRACKETS ASSEMBLIES ONTO EACH SIDE OF THE 2"x4"x48" EXTRUSION.
- TOP BRACKETS CAN BE LEFT LOOSE FOR NOW.
- POSITION BOTTOM BRACKETS SO THEY ARE FLUSH WITH BOTTOM OF ALUMINUM EXTRUSION
- TIGHTEN BRACKETS TO EXTRUSION.

NOTE:

1.

| REV. | DESCRIPTION | DATE | NAME | ECN NO. |
|----------------|-----------------|----------|------|---------|
| A | CREATED DRAWING | 12/22/16 | EMR | - |
| REVISION LEVEL | | | | |

| | | | | |
|---|---------|-----|-----------|----------|
| ALL DIMENSIONS ARE IN INCHES UNLESS NOTED OTHERWISE | DWN BY: | EMR | DATE DWN: | 12/22/16 |
| DECIMALS: $X = \pm .000$ | APR BY: | | DATE APR: | |
| XX = $\pm .020$ | APR BY: | | DATE APR: | |
| XXX = $\pm .010$ | APR BY: | | DATE APR: | |
| ANGLES: $= \pm 1^{\circ}0'$ | APR BY: | | DATE APR: | |
| CABINET SQUARENESS: $= \pm .0625$ | APR BY: | | DATE APR: | |

CONFIDENTIAL:
ALL DESIGN RIGHTS RESERVED
THE INFORMATION, DATA, DESIGN, AND DRAWINGS EMBODIED IN THIS DOCUMENT AND ALL REPRODUCTIONS THEREOF ARE THE EXCLUSIVE PROPERTY OF DIVERSIFIED WOODCRAFTS, INC.

THESE DOCUMENTS ARE SUPPLIED WITH THE UNDERSTANDING THAT THEY WILL NOT BE DISCLOSED TO THIRD PARTIES WITHOUT WRITTEN CONSENT OF DIVERSIFIED WOODCRAFTS, INC. ANY REPRODUCTION IN PART OR WHOLE WITHOUT WRITTEN CONSENT IS SUBJECT TO LEGAL ACTION.

| | | |
|-----------------|---|-------------------------|
| | 300 South Krueger Street Suring, WI 54174 diversifiedwoodcrafts.com | |
| | TITLE: AUGMENTED REALITY SANDBOX ASSEMBLY INSTRUCTIONS | |
| DRAWING NUMBER: | ARS-4030 | SCALE: SHEET: REVISION: |
| | NTS | 11 OF 19 REV A |

STEP 9:

- ATTACH ALUMINUM EXTRUSION ASSEMBLY 1 TO SANDBOX AND MOUNTING BLOCK.
- POSITION L-BRACKETS TO HOLES ON TOP OF SANDBOX AND TO HOLES ON MOUNTING BLOCK.
- ATTACH L-BRACKETS BY INSERTING CONFIRMATS ON OUTSIDE OF SANDBOX AND MOUNTING BLOCK AND THE JOINT CONNECTING NUT ON INSIDE.
- TIGHTEN CONFIRMATS AND THEN TIGHTEN TOP L-BRACKET SCREWS.

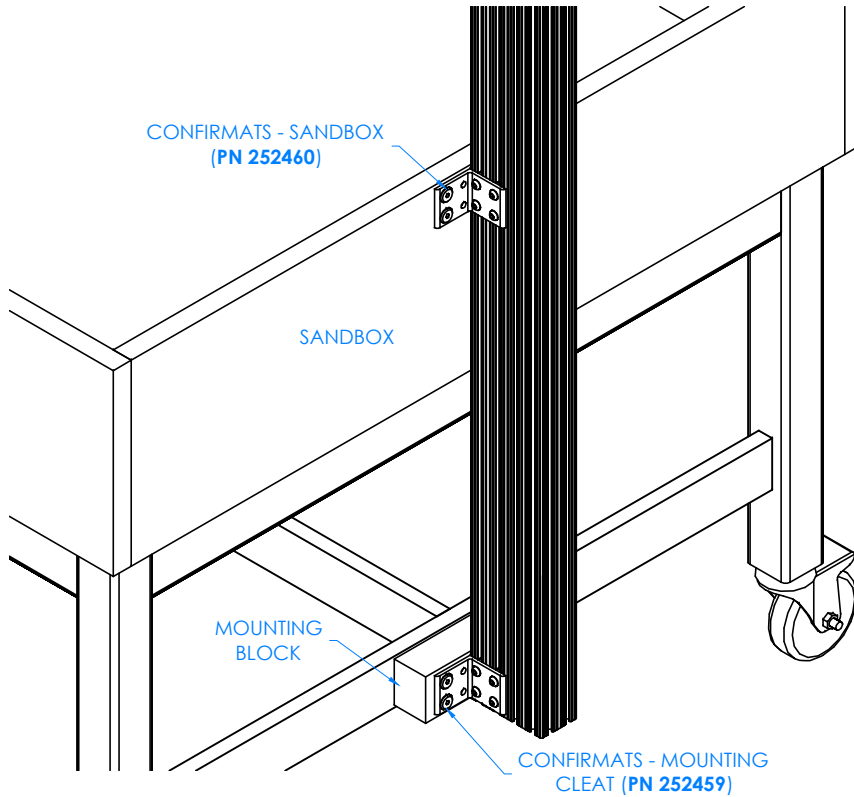

OUTSIDE OF SANDBOX ASSEMBLY SHOWN

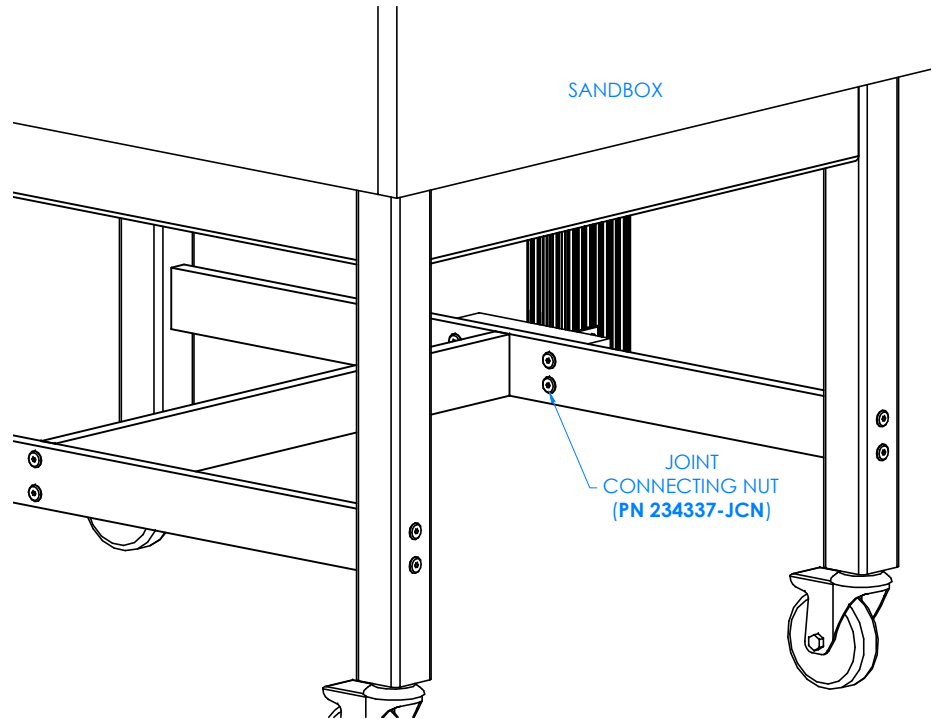

INSIDE OF SANDBOX ASSEMBLY SHOWN

| | | | | |
|---|---------|-----|-----------|----------|
| ALL DIMENSIONS ARE IN INCHES UNLESS NOTED OTHERWISE | DWN BY: | EMR | DATE DWN: | 12/22/16 |
| DECIMALS: X = ± .000 | APR BY: | | DATE APR: | |
| XX = ± .020 | APR BY: | | DATE APR: | |
| XXX = ± .010 | APR BY: | | DATE APR: | |
| ANGLES: = ± 1° | APR BY: | | DATE APR: | |
| CABINET SQUARENESS: = ± .0625 | APR BY: | | DATE APR: | |

CONFIDENTIAL:
 ALL DESIGN RIGHTS RESERVED
 THE INFORMATION, DATA, DESIGN, AND DRAWINGS EMBODIED IN THIS DOCUMENT AND ALL REPRODUCTIONS THEREOF ARE THE EXCLUSIVE PROPERTY OF DIVERSIFIED WOODCRAFTS, INC.

THESE DOCUMENTS ARE SUPPLIED WITH THE UNDERSTANDING THAT THEY WILL NOT BE DISCLOSED TO THIRD PARTIES WITHOUT WRITTEN CONSENT OF DIVERSIFIED WOODCRAFTS, INC. ANY REPRODUCTION IN PART OR WHOLE WITHOUT WRITTEN CONSENT IS SUBJECT TO LEGAL ACTION.



300 South Krueger Street
 Suring, WI 54174
 diversifiedwoodcrafts.com

TITLE:
AUGMENTED REALITY SANDBOX ASSEMBLY INSTRUCTIONS

| REV. | DESCRIPTION | DATE | NAME | ECN NO. |
|------|-----------------|----------|------|---------|
| A | CREATED DRAWING | 12/22/16 | EMR | - |

REVISION LEVEL

| | | | |
|-----------------|--------|----------|-----------|
| DRAWING NUMBER: | SCALE: | SHEET: | REVISION: |
| ARS-4030 | NTS | 12 OF 19 | REV A |

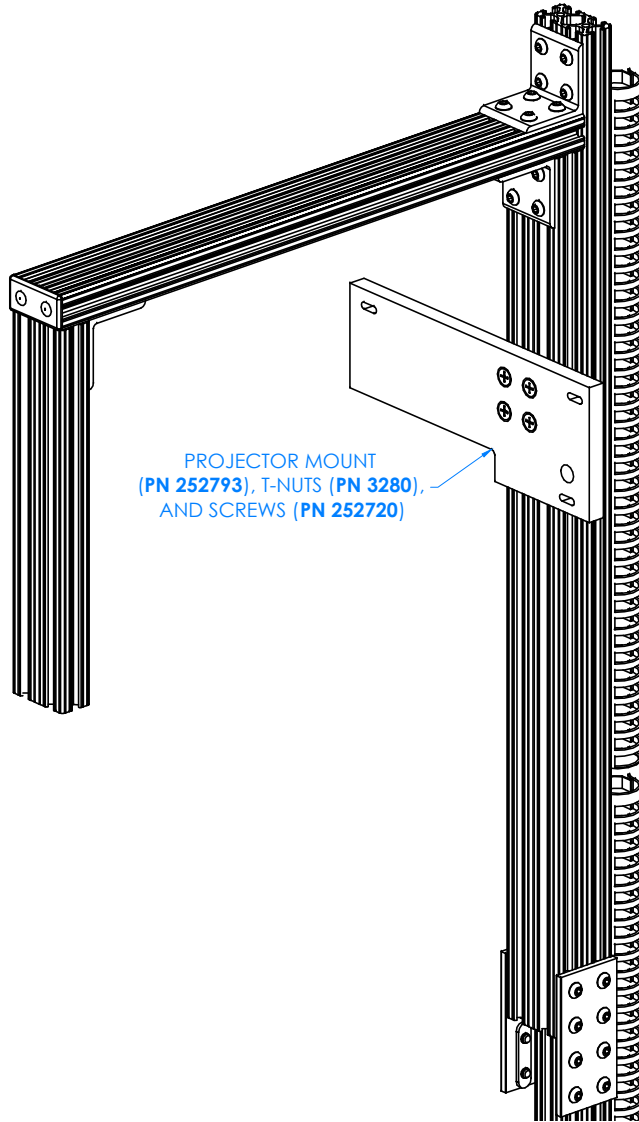

STEP 10:

- SLIDE PROJECTOR MOUNTING BLOCK ONTO ALUMINUM EXTRUSION ASSEMBLY (BUILT IN THE PREVIOUS SET OF INSTRUCTIONS) FROM BOTTOM.
- ATTACH WITH HARDWARE PROVIDED.
- DO NOT TIGHTEN ALL THE WAY.

NOTE:

1.

| | | | | |
|---|---------|-----|-----------|----------|
| ALL DIMENSIONS ARE IN INCHES UNLESS NOTED OTHERWISE | DWN BY: | EMR | DATE DWN: | 12/22/16 |
| DECIMALS: $X = \pm .000$ | APR BY: | | DATE APR: | |
| $XX = \pm .020$ | APR BY: | | DATE APR: | |
| $XXX = \pm .010$ | APR BY: | | DATE APR: | |
| ANGLES: $= \pm 1^{\circ}0'$ | APR BY: | | DATE APR: | |
| CABINET SQUARENESS: $= \pm .0625$ | APR BY: | | DATE APR: | |

CONFIDENTIAL:
 ALL DESIGN RIGHTS RESERVED
 THE INFORMATION, DATA, DESIGN, AND DRAWINGS EMBODIED IN THIS DOCUMENT AND ALL REPRODUCTIONS THEREOF ARE THE EXCLUSIVE PROPERTY OF DIVERSIFIED WOODCRAFTS, INC.

THESE DOCUMENTS ARE SUPPLIED WITH THE UNDERSTANDING THAT THEY WILL NOT BE DISCLOSED TO THIRD PARTIES WITHOUT WRITTEN CONSENT OF DIVERSIFIED WOODCRAFTS, INC. ANY REPRODUCTION IN PART OR WHOLE WITHOUT WRITTEN CONSENT IS SUBJECT TO LEGAL ACTION.



300 South Krueger Street
 Suring, WI 54174
 diversifiedwoodcrafts.com

TITLE:
 AUGMENTED REALITY SANDBOX
 ASSEMBLY INSTRUCTIONS

| REV. | DESCRIPTION | DATE | NAME | ECN NO. |
|----------------|-----------------|----------|------|---------|
| A | CREATED DRAWING | 12/22/16 | EMR | - |
| REVISION LEVEL | | | | |

| | | | | | | | |
|-----------------|----------|--------|-----|--------|----------|-----------|-------|
| DRAWING NUMBER: | ARS-4030 | SCALE: | NTS | SHEET: | 13 OF 19 | REVISION: | REV A |
|-----------------|----------|--------|-----|--------|----------|-----------|-------|

ALUMINUM EXTRUSION ASSEMBLY

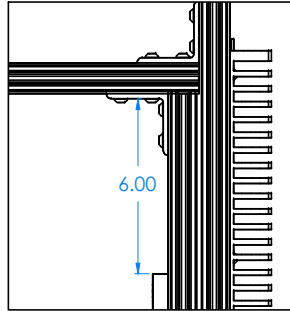
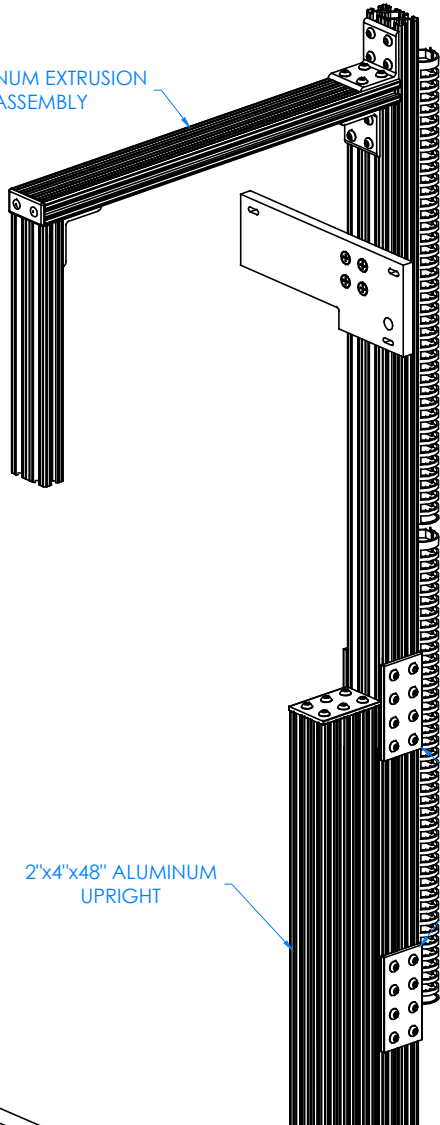

TIGHTEN ASSEMBLIES
HERE (BOTH SIDES)

2"x4"x48" ALUMINUM
UPRIGHT

STEP 11:

- SLIDE ALUMINUM EXTRUSION ASSEMBLY ONTO THE 2"x4"x48" ALUMINUM UPRIGHT .
- TIGHTEN ASSEMBLIES TOGETHER.
- MAKE SURE ALL SCREWS ARE TIGHT BEFORE MOVING ON.
- GO BACK TO STEP 10 AND TIGHTEN PROJECTOR MOUNTING BLOCK ONTO ALUMINUM EXTRUSION ASSEMBLY 2.
- MAKE SURE TOP OF MOUNT SITS 6" FROM THE BOTTOM OF CORNER L-BRACKET.
- FINAL DIMENSION WILL BE ADJUSTED ONCE CAMERA AND PROJECTOR ARE MOUNTED IN STEP 14.

| | | | | |
|---|---------|-----|-----------|----------|
| ALL DIMENSIONS ARE IN INCHES UNLESS NOTED OTHERWISE | DWN BY: | EMR | DATE DWN: | 12/22/16 |
| DECIMALS: X = ± .000 | APR BY: | | DATE APR: | |
| XX = ± .020 | APR BY: | | DATE APR: | |
| XXX = ± .010 | APR BY: | | DATE APR: | |
| ANGLES: = ± 1°0' | APR BY: | | DATE APR: | |
| CABINET SQUARENESS: = ± .0625 | APR BY: | | DATE APR: | |

CONFIDENTIAL:
ALL DESIGN RIGHTS RESERVED
THE INFORMATION, DATA, DESIGN, AND DRAWINGS EMBODIED IN THIS DOCUMENT AND ALL REPRODUCTIONS THEREOF ARE THE EXCLUSIVE PROPERTY OF DIVERSIFIED WOODCRAFTS, INC.

THESE DOCUMENTS ARE SUPPLIED WITH THE UNDERSTANDING THAT THEY WILL NOT BE DISCLOSED TO THIRD PARTIES WITHOUT WRITTEN CONSENT OF DIVERSIFIED WOODCRAFTS, INC. ANY REPRODUCTION IN PART OR WHOLE WITHOUT WRITTEN CONSENT IS SUBJECT TO LEGAL ACTION.



300 South Krueger Street
Suring, WI 54174
diversifiedwoodcrafts.com

TITLE:
AUGMENTED REALITY SANDBOX
ASSEMBLY INSTRUCTIONS

| REV. | DESCRIPTION | DATE | NAME | ECN NO. |
|----------------|-----------------|----------|------|---------|
| A | CREATED DRAWING | 12/22/16 | EMR | - |
| REVISION LEVEL | | | | |

| | | | |
|-----------------|--------|----------|-----------|
| DRAWING NUMBER: | SCALE: | SHEET: | REVISION: |
| ARS-4030 | NTS | 14 OF 19 | REV A |

STEP 12:

- SLIDE LAPTOP SHELF L-BRACKETS UP THE SIDES OF THE T-SLOTTED PROFILE UNTIL THEY ARE TIGHT TO THE 8-HOLE FLAT PLATE.
- TIGHTEN SCREWS.
- SLIDE BOTTOM END OF THE DROP LEAF SUPPORT UP THE FACE OF THE T-SLOTTED PROFILE, GUIDING ATTACHED T-NUTS INTO GROOVES.
- FULLY ENGAGE DROP LEAF AND RAISE IT UP UNTIL SHELF IS SITTING PARALLEL TO FLOOR.
- TIGHTEN SCREWS TO SECURE IT IN PLACE.

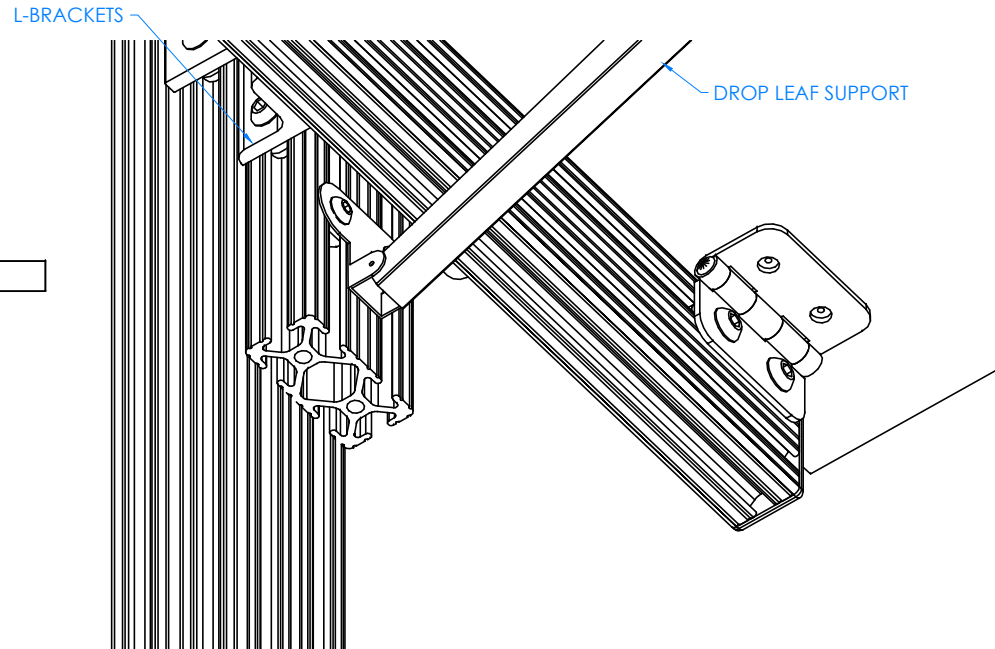
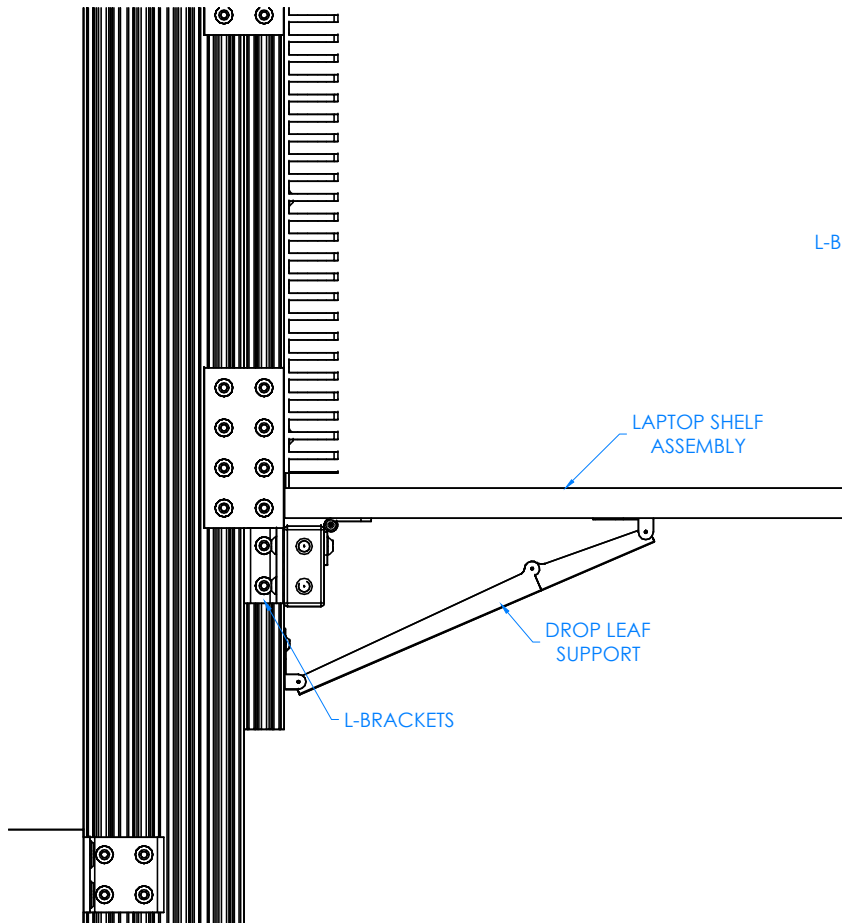

UNDERSIDE OF DROP LEAF SHOWN

NOTE:

1.

| | | | | |
|---|---------|-----|-----------|----------|
| ALL DIMENSIONS ARE IN INCHES UNLESS NOTED OTHERWISE | DWN BY: | EMR | DATE DWN: | 12/22/16 |
| DECIMALS: X = ± .030 | APR BY: | | DATE APR: | |
| XX = ± .020 | APR BY: | | DATE APR: | |
| XXX = ± .010 | APR BY: | | DATE APR: | |
| ANGLES: = ± 1°0' | APR BY: | | DATE APR: | |
| CABINET SQUARENESS: = ± .0625 | APR BY: | | DATE APR: | |

CONFIDENTIAL:
ALL DESIGN RIGHTS RESERVED
THE INFORMATION, DATA, DESIGN, AND DRAWINGS EMBODIED IN THIS DOCUMENT AND ALL REPRODUCTIONS THEREOF ARE THE EXCLUSIVE PROPERTY OF DIVERSIFIED WOODCRAFTS, INC.

THESE DOCUMENTS ARE SUPPLIED WITH THE UNDERSTANDING THAT THEY WILL NOT BE DISCLOSED TO THIRD PARTIES WITHOUT WRITTEN CONSENT OF DIVERSIFIED WOODCRAFTS, INC. ANY REPRODUCTION IN PART OR WHOLE WITHOUT WRITTEN CONSENT IS SUBJECT TO LEGAL ACTION.



300 South Krueger Street
Suring, WI 54174
diversifiedwoodcrafts.com

TITLE:
**AUGMENTED REALITY SANDBOX
ASSEMBLY INSTRUCTIONS**

| REV. | DESCRIPTION | DATE | NAME | ECN NO. |
|----------------|-----------------|----------|------|---------|
| A | CREATED DRAWING | 12/22/16 | EMR | - |
| REVISION LEVEL | | | | |

| | | | |
|-----------------|--------|----------|-----------|
| DRAWING NUMBER: | SCALE: | SHEET: | REVISION: |
| ARS-4030 | NTS | 15 OF 19 | REV A |

ALUMINUM EXTRUSION ASSEMBLY

CAMERA MOUNT PLATE (PN 4141), MOUNTING SCREWS FOR EXTRUSION (PN 3321), KINECT MOUNTING SCREW (PN *257893* SEE NOTE 2)

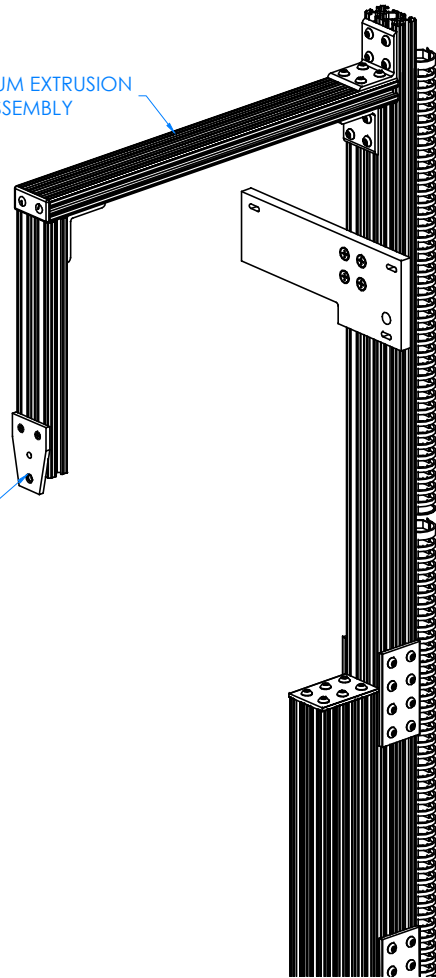

STEP 13:

- SLIDE CAMERA MOUNT UP ONTO ALUMINUM EXTRUSION ASSEMBLY, GUIDING THE T-NUTS INTO THE SLOTS.
- SLIDE IT UP UNTIL BOTTOM LIP OF MOUNT IS AGAINST THE ALUMINUM.
- TIGHTEN SCREWS.

NOTE:

1. ELECTRONIC COMPONENTS NOT SHOWN.
2. T-NUTS COME AS AN ASSEMBLY WITH SCREWS ALREADY ATTACHED, THEY ARE NOT NEEDED AND CAN BE DISCARDED. USE SCREWS LISTED WITH THIS STEP.

| A | CREATED DRAWING | 12/22/16 | EMR | - |
|----------------|-----------------|----------|------|---------|
| REV. | DESCRIPTION | DATE | NAME | ECN NO. |
| REVISION LEVEL | | | | |

| | | |
|---|-------------|--------------------|
| ALL DIMENSIONS ARE IN INCHES UNLESS NOTED OTHERWISE DECIMALS: X = ± .000 XX = ± .020 XXX = ± .010 ANGLES: = ± 1° CABINET SQUARENESS: = ± .0625 | DWN BY: EMR | DATE DWN: 12/22/16 |
| | APR BY: | DATE APR: |
| | APR BY: | DATE APR: |

CONFIDENTIAL:
ALL DESIGN RIGHTS RESERVED
THE INFORMATION, DATA, DESIGN, AND DRAWINGS EMBODIED IN THIS DOCUMENT AND ALL REPRODUCTIONS THEREOF ARE THE EXCLUSIVE PROPERTY OF DIVERSIFIED WOODCRAFTS, INC.

THESE DOCUMENTS ARE SUPPLIED WITH THE UNDERSTANDING THAT THEY WILL NOT BE DISCLOSED TO THIRD PARTIES WITHOUT WRITTEN CONSENT OF DIVERSIFIED WOODCRAFTS, INC. ANY REPRODUCTION IN PART OR WHOLE WITHOUT WRITTEN CONSENT IS SUBJECT TO LEGAL ACTION.



300 South Krueger Street
Surging, WI 54174
diversifiedwoodcrafts.com

TITLE:
AUGMENTED REALITY SANDBOX
ASSEMBLY INSTRUCTIONS

| | | | |
|------------------------------------|---------------|--------------------|--------------------|
| DRAWING NUMBER: ARS-4030 | SCALE: NTS | SHEET: 16 OF 19 | REVISION: REV A |
|------------------------------------|---------------|--------------------|--------------------|

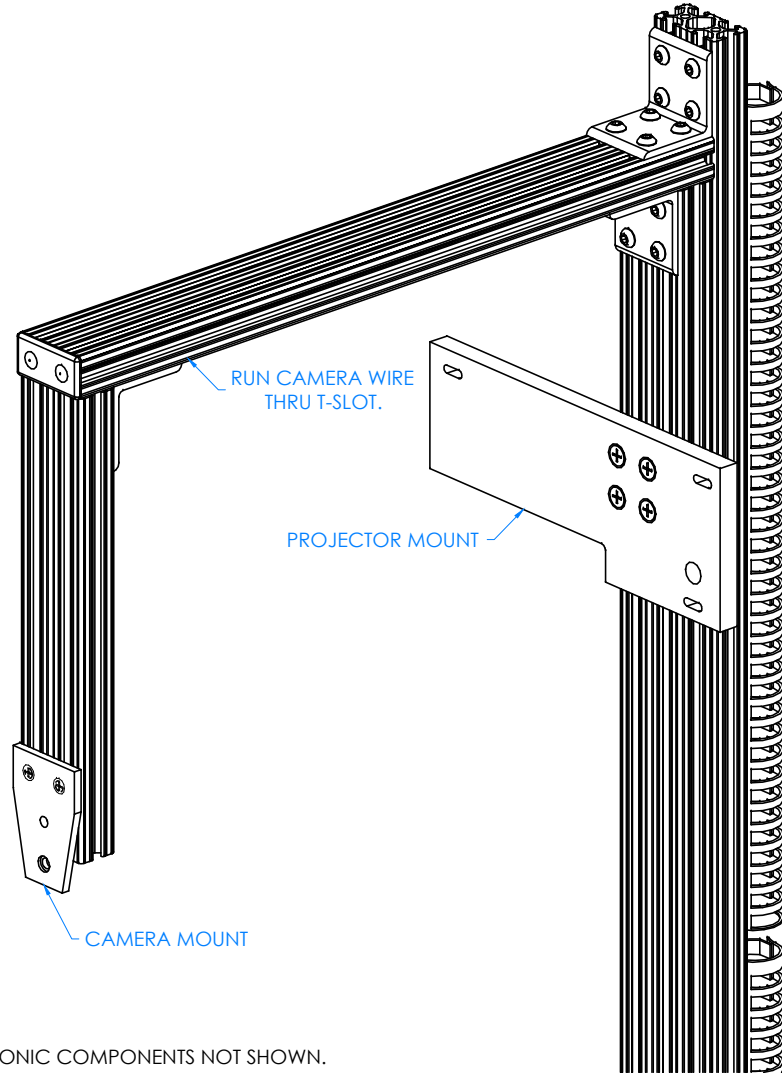

STEP 14:

- PLUG IN WIRES TO PROJECTOR PRIOR TO MOUNTING IF APPLICABLE - SEE SHEET 19 ON THE WIRING DIAGRAM.
- LINE PROJECTOR UP WITH THE (3) MOUNTING HOLES IN BRACKET AND ATTACH USING THE (3) SCREWS (PN 252719) PROVIDED.
- SNUG THE SCREWS AND MAKE SURE PROJECTOR IS AS PARALLEL TO SANDBOX AS POSSIBLE AND TIGHTEN.
- BOLT KINECT 3D CAMERA ONTO CAMERA MOUNT.
- DOUBLE CHECK TO MAKE SURE LENS ON PROJECTOR IS IN LINE WITH THE KINECT CAMERA, IF NOT ADJUST PROJECTOR MOUNTING BLOCK UP OR DOWN AS NEEDED AND RE-MOUNT PROJECTOR.
- KINECT CABLE CAN BE RUN INSIDE THE T-SLOT ON SIDE OR TOP OF ALUMINUM OR.

NOTE:

1. ELECTRONIC COMPONENTS NOT SHOWN.

| | | | | |
|---|---------|-----|-----------|----------|
| ALL DIMENSIONS ARE IN INCHES UNLESS NOTED OTHERWISE | DWN BY: | EMR | DATE DWN: | 12/22/16 |
| DECIMALS: $X = \pm .000$ | APR BY: | | DATE APR: | |
| $XX = \pm .020$ | APR BY: | | DATE APR: | |
| $XXX = \pm .010$ | APR BY: | | DATE APR: | |
| ANGLES: $= \pm 1^{\circ}0'$ | APR BY: | | DATE APR: | |
| CABINET SQUARENESS: $= \pm .0625$ | APR BY: | | DATE APR: | |

CONFIDENTIAL:
 ALL DESIGN RIGHTS RESERVED
 THE INFORMATION, DATA, DESIGN, AND DRAWINGS EMBODIED IN THIS DOCUMENT AND ALL REPRODUCTIONS THEREOF ARE THE EXCLUSIVE PROPERTY OF DIVERSIFIED WOODCRAFTS, INC.

THESE DOCUMENTS ARE SUPPLIED WITH THE UNDERSTANDING THAT THEY WILL NOT BE DISCLOSED TO THIRD PARTIES WITHOUT WRITTEN CONSENT OF DIVERSIFIED WOODCRAFTS, INC. ANY REPRODUCTION IN PART OR WHOLE WITHOUT WRITTEN CONSENT IS SUBJECT TO LEGAL ACTION.

300 South Krueger Street
 Suring, WI 54174
 diversifiedwoodcrafts.com

TITLE:
**AUGMENTED REALITY SANDBOX
 ASSEMBLY INSTRUCTIONS**

| REV. | DESCRIPTION | DATE | NAME | ECN NO. |
|----------------|-----------------|----------|------|---------|
| A | CREATED DRAWING | 12/22/16 | EMR | - |
| REVISION LEVEL | | | | |

| | | | | | | | |
|-----------------|----------|--------|-----|--------|----------|-----------|-------|
| DRAWING NUMBER: | ARS-4030 | SCALE: | NTS | SHEET: | 17 OF 19 | REVISION: | REV A |
|-----------------|----------|--------|-----|--------|----------|-----------|-------|

STEP 15:

- YOUR AUGMENTED REALITY SANDBOX IS NOW ASSEMBLED.
- WE RECOMMEND USING SANDTASTIK THERAPY SAND BUT ANY DRY, WHITE SAND WILL WORK - IT WILL TAKE 200-250LBS.
- SAND SHOULD BE FILLED AT LEAST HALFWAY UP THE BOX.
- SETUP AND CALIBRATE LAPTOP AND PROJECTOR BY PLUGGING IN ELECTRONIC COMPONENTS AND CONNECTING FLASH DRIVE TO IT - FURTHER INSTRUCTIONS WILL FOLLOW.
- PROCEED WITH THE SETUP - SEE SHEET 19 FOR WIRE DIAGRAM.

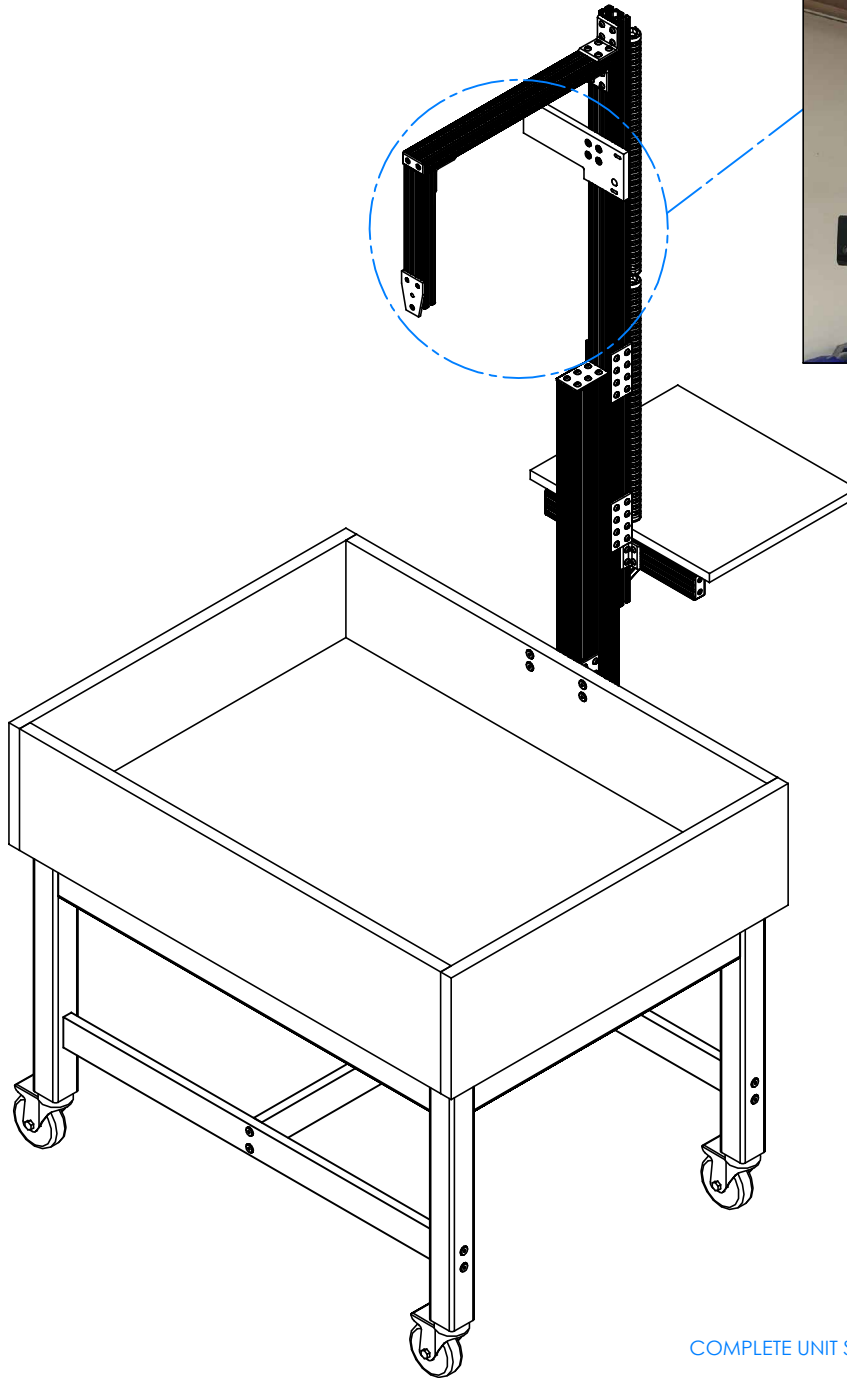

COMPLETE UNIT SHOWN

NOTE:

1.

| | | | | | |
|---|--|---------|-----|-----------|----------|
| ALL DIMENSIONS ARE IN INCHES UNLESS NOTED OTHERWISE | | DWN BY: | EMR | DATE DWN: | 12/22/16 |
| DECIMALS: .X = ± .030 | | APR BY: | | DATE APR: | |
| .XX = ± .020 | | APR BY: | | DATE APR: | |
| .XXX = ± .010 | | APR BY: | | DATE APR: | |
| ANGLES: ± 1° | | APR BY: | | DATE APR: | |
| CABINET SQUARENESS: ± .0625 | | APR BY: | | DATE APR: | |

CONFIDENTIAL:
ALL DESIGN RIGHTS RESERVED
THE INFORMATION, DATA, DESIGN, AND DRAWINGS EMBODIED IN THIS DOCUMENT AND ALL REPRODUCTIONS THEREOF ARE THE EXCLUSIVE PROPERTY OF DIVERSIFIED WOODCRAFTS, INC.

THESE DOCUMENTS ARE SUPPLIED WITH THE UNDERSTANDING THAT THEY WILL NOT BE DISCLOSED TO THIRD PARTIES WITHOUT WRITTEN CONSENT OF DIVERSIFIED WOODCRAFTS, INC. ANY REPRODUCTION IN PART OR WHOLE WITHOUT WRITTEN CONSENT IS SUBJECT TO LEGAL ACTION.



300 South Krueger Street
Suring, WI 54174
diversifiedwoodcrafts.com

TITLE:
AUGMENTED REALITY SANDBOX
ASSEMBLY INSTRUCTIONS

| REV. | DESCRIPTION | DATE | XYZ | N/A | ECN No. |
|----------------|-----------------|-------|-----|-----|---------|
| A | CREATED DRAWING | X/X/X | XYZ | N/A | ECN No. |
| REVISION LEVEL | | | | | |

| | | | |
|-----------------|--------|----------|-----------|
| DRAWING NUMBER: | SCALE: | SHEET: | REVISION: |
| ARS-4030 | NTS | 18 OF 19 | REV A |

WIRING DIAGRAM

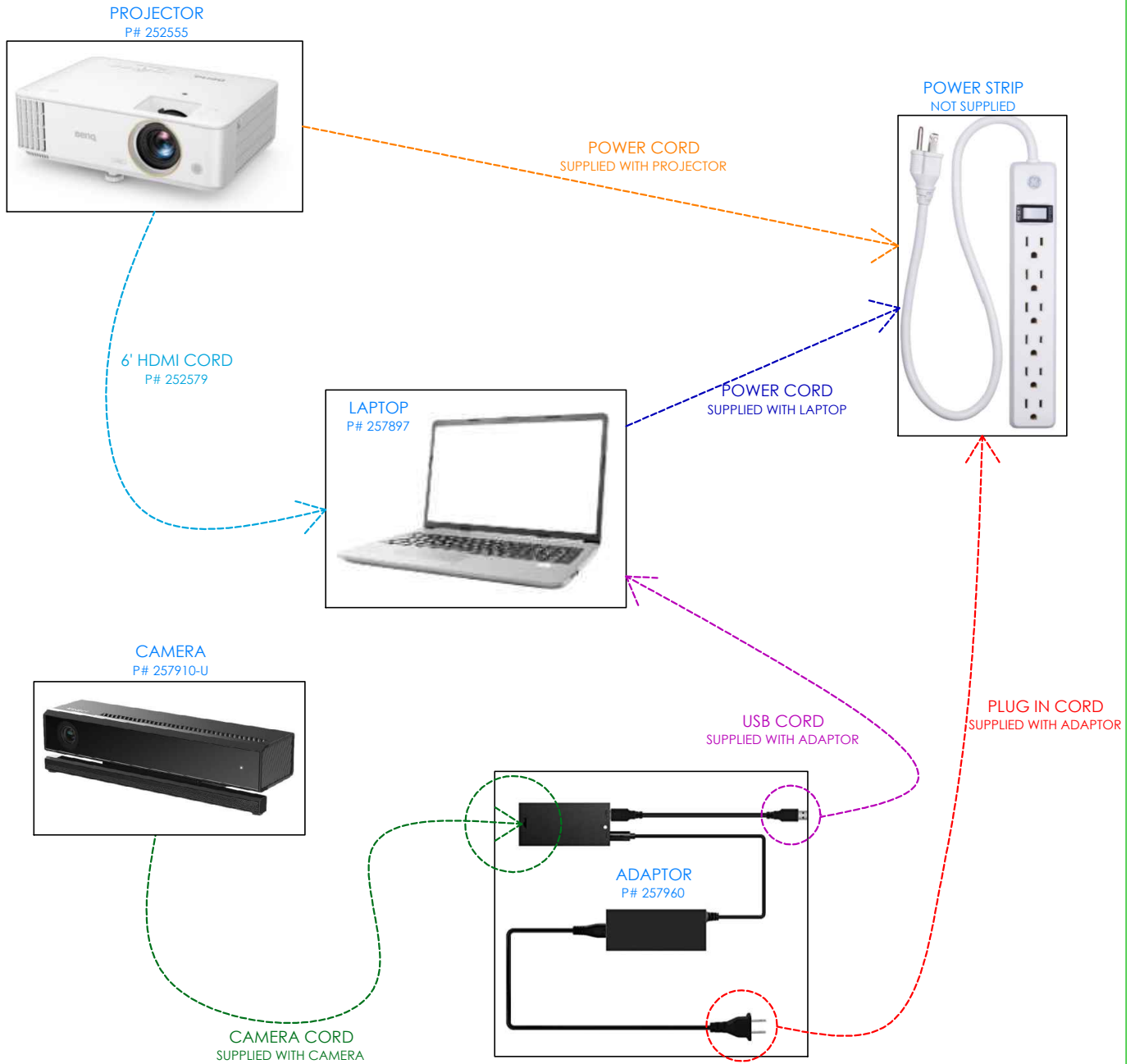

NOTE:

- IMAGES MAY NOT REPRESENT EXACT MODELS PURCHASED - THIS IS JUST A VISUAL.**

| | | | | |
|---|---------|-----|-----------|----------|
| ALL DIMENSIONS ARE IN INCHES UNLESS NOTED OTHERWISE | DWN BY: | EMR | DATE DWN: | 12/22/16 |
| DECIMALS: X = ± .030 | APR BY: | | DATE APR: | |
| XX = ± .020 | APR BY: | | DATE APR: | |
| XXX = ± .010 | APR BY: | | DATE APR: | |
| ANGLES: ± 1° | | | | |
| CABINET SQUARENESS: ± .0625 | | | | |

CONFIDENTIAL:
ALL DESIGN RIGHTS RESERVED
THE INFORMATION, DATA, DESIGN, AND DRAWINGS EMBODIED IN THIS DOCUMENT AND ALL REPRODUCTIONS THEREOF ARE THE EXCLUSIVE PROPERTY OF DIVERSIFIED WOODCRAFTS, INC.

THESE DOCUMENTS ARE SUPPLIED WITH THE UNDERSTANDING THAT THEY WILL NOT BE DISCLOSED TO THIRD PARTIES WITHOUT WRITTEN CONSENT OF DIVERSIFIED WOODCRAFTS, INC. ANY REPRODUCTION IN PART OR WHOLE WITHOUT WRITTEN CONSENT IS SUBJECT TO LEGAL ACTION.



300 South Krueger Street
Suring, WI 54174
diversifiedwoodcrafts.com

TITLE:
AUGMENTED REALITY SANDBOX ASSEMBLY INSTRUCTIONS

| REV. | CREATED DRAWING DESCRIPTION | X/X/X | XYZ | N/A |
|----------------|-----------------------------|-------|------|---------|
| REV. | DESCRIPTION | DATE | NAME | ECN No. |
| REVISION LEVEL | | | | |

| | | | |
|-----------------|--------|----------|-----------|
| DRAWING NUMBER: | SCALE: | SHEET: | REVISION: |
| ARS-4030 | NTS | 19 OF 19 | REV A |