

MOBILE CLAY CART

C-38 ASSEMBLY INSTRUCTIONS

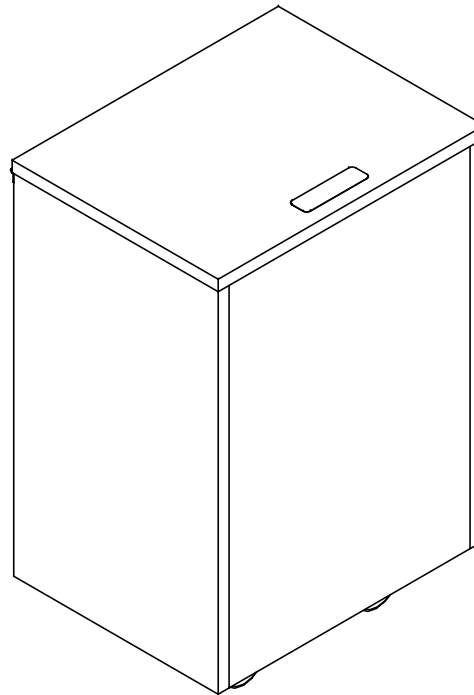

NOTE:

1. MODEL VIEWS MAY NOT REPRESENT EXACT MODEL PURCHASED

DWN BY:	EMK	DWN DATE:	9/17/14
APR BY:		DATE APR:	
APR BY:		DATE APR:	



300 South Krueger Street
Suring, WI 54174
diversifiedwoodcrafts.com

UNLESS OTHERWISE SPECIFIED
DIMENSION ARE IN INCHES
CABINET SQUARENESS ± .0625
FRACTIONAL VALUES ± 1/32"
- ALL VALUES ± OVERALL -

TITLE:
MOBILE CLAY CART
ASSEMBLY INSTRUCTIONS

REV.	DESCRIPTION	DATE	NAME	ECN NO.
A	CREATED ASSEMBLY INSTRUCTIONS	9/17/14	EMK	-

THIS DRAWING IS THE SOLE PROPERTY OF
DIVERSIFIED WOOD CRAFTS. IT MAY NOT
BE ALTERED OR CHANGED WITHOUT
PERMISSION

DRAWING NUMBER:	C-38	SCALE:	NTS	SHEET:	1 OF 3	REVISION:	REV A
-----------------	------	--------	-----	--------	--------	-----------	-------

TOOLS REQUIRED

1/2" WRENCH

ADJUSTABLE PLIERS

ASSEMBLY COMPONENTS

ITEMS INCLUDED	PART #	PART DESCRIPTION	QTY
CLAY CART INSERT	15-0014	CLAY CART INSERTS	1
CASTERS	222033	CASTER,3 POLY. SWIVEL PLATE, W BRAKE	4
CASTER HARDWARE KIT	206509	CASTER,ASSY,HDWRE,16-SCREW,16-NUTS	1

NOTE:

1.

DWN BY:	EMK	DWN DATE:	9/17/14
APR BY:		DATE APR:	
APR BY:		DATE APR:	



300 South Krueger Street
 Suring, WI 54174
 diversifiedwoodcrafts.com

UNLESS OTHERWISE SPECIFIED
 DIMENSION ARE IN INCHES
 CABINET SQUARENESS ± .0625
 FRACTIONAL VALUES ± 1/32"
 - ALL VALUES ± OVERALL -

TITLE:
**MOBILE CLAY CART
 TOOLS AND ASSEMBLY COMPONENTS**

REV.	DESCRIPTION	DATE	NAME	ECN NO.
A	CREATED ASSEMBLY INSTRUCTIONS	9/17/14	EMK	-

REVISION LEVEL

THIS DRAWING IS THE SOLE PROPERTY OF
 DIVERSIFIED WOOD CRAFTS. IT MAY NOT
 BE ALTERED OR CHANGED WITHOUT
 PERMISSION

DRAWING NUMBER:

C-38

SCALE:	SHEET:	REVISION:
NTS	2 OF 3	REV A

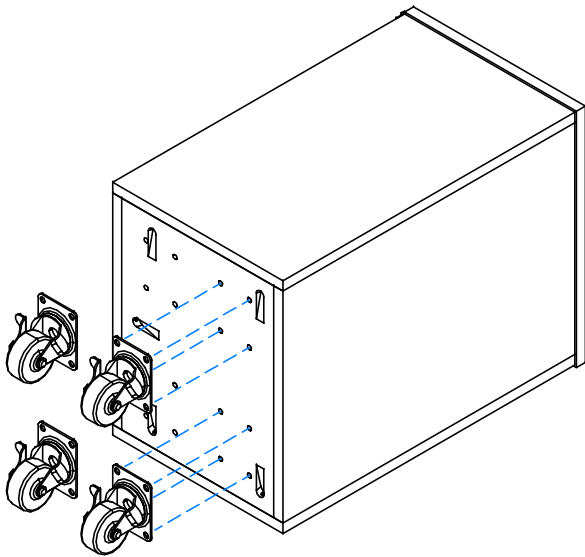

STEP 1:
LAY CART ON SIDE AND ATTACH THE CASTERS FROM INSIDE OF CART USING THE HARDWARE PROVIDED.

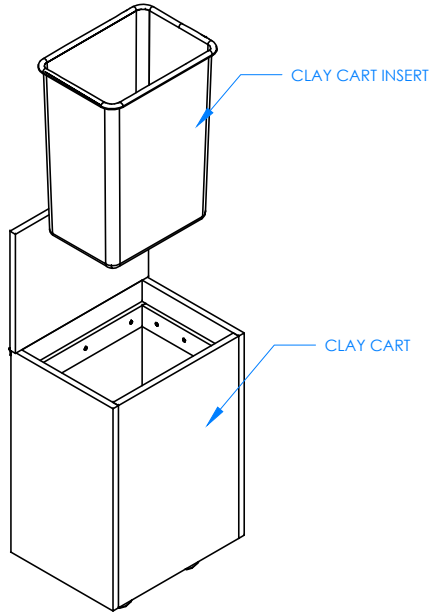

STEP 2:
TIP CART UP AND PUT INSERT INTO THE CART.

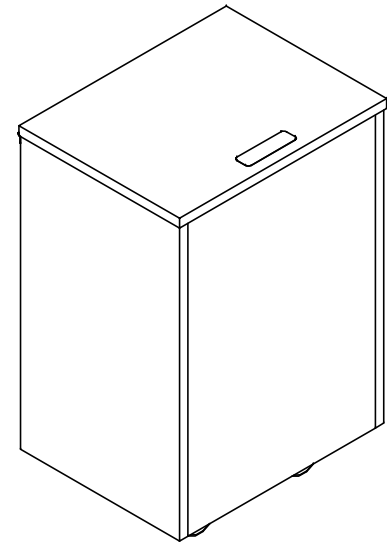

COMPLETE UNIT SHOWN

STEP 3:
PLACE CART IN DESIRED LOCATION.

NOTE:

- 1.

DWN BY:	EMK	DWN DATE:	9/17/14
APR BY:		DATE APR:	
APR BY:		DATE APR:	

UNLESS OTHERWISE SPECIFIED
DIMENSION ARE IN INCHES
CABINET SQUARENESS ± .0625
FRACTIONAL VALUES ± 1/32"
- ALL VALUES ± OVERALL -



300 South Krueger Street
Suring, WI 54174
diversifiedwoodcrafts.com

TITLE:
MOBILE CLAY CART
ASSEMBLY INSTRUCTIONS

REV.	DESCRIPTION	DATE	NAME	ECH NO.
A	CREATED ASSEMBLY INSTRUCTIONS	9/17/14	EMK	-
REVISION LEVEL				

THIS DRAWING IS THE SOLE PROPERTY OF
DIVERSIFIED WOOD CRAFTS. IT MAY NOT
BE ALTERED OR CHANGED WITHOUT
PERMISSION

DRAWING NUMBER:	SCALE:	SHEET:	REVISION:
C-38	NTS	3 OF 3	REV A