

# CUBBY CABINET

CC SERIES - METAL SHELF (OAK OR MAPLE)  
ASSEMBLY INSTRUCTIONS

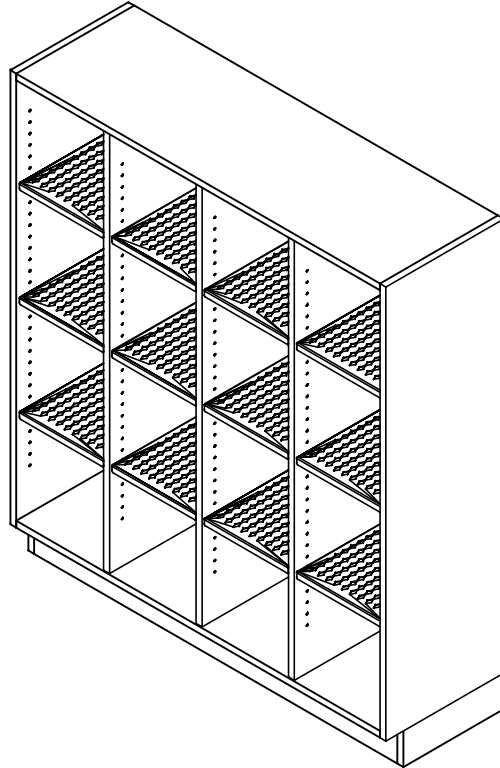

**NOTE:**

1. MODEL VIEWS MAY NOT REPRESENT EXACT MODEL PURCHASED

ALL DIMENSIONS ARE IN INCHES UNLESS NOTED OTHERWISE	DWN BY:	EMR	DATE DWN:	8/23/21
DECIMALS: X = ± .000	APR BY:		DATE APR:	
XX = ± .020	APR BY:		DATE APR:	
XXX = ± .010	APR BY:		DATE APR:	
ANGLES: = ± 1°0'	APR BY:		DATE APR:	
CABINET SQUARENESS: = ± .0625	APR BY:		DATE APR:	

CONFIDENTIAL:  
ALL DESIGN RIGHTS RESERVED  
THE INFORMATION, DATA, DESIGN, AND DRAWINGS EMBODIED IN THIS DOCUMENT AND ALL REPRODUCTIONS THEREOF ARE THE EXCLUSIVE PROPERTY OF DIVERSIFIED WOODCRAFTS, INC.

THESE DOCUMENTS ARE SUPPLIED WITH THE UNDERSTANDING THAT THEY WILL NOT BE DISCLOSED TO THIRD PARTIES WITHOUT WRITTEN CONSENT OF DIVERSIFIED WOODCRAFTS, INC. ANY REPRODUCTION IN PART OR WHOLE WITHOUT WRITTEN CONSENT IS SUBJECT TO LEGAL ACTION.



300 South Krueger Street  
Suring, WI 54174  
diversifiedwoodcrafts.com

TITLE:  
**CUBBY CABINET  
ASSEMBLY INSTRUCTIONS**

REV.	DESCRIPTION	DATE	NAME	ECN NO.
A	CREATED DRAWING	8/23/21	EMR	-
REVISION LEVEL				

DRAWING NUMBER:	SCALE:	SHEET:	REVISION:
<b>CC SERIES - METAL SHELF</b>	NTS	1 OF 5	REV A

## TOOLS REQUIRED

DRILL
CONTACT CEMENT
SCREW DRIVER

## ASSEMBLY COMPONENTS

ITEMS INCLUDED	PART #	PART DESCRIPTION	QTY
RUBBER BASE	100283	RUBBER BASE MOLDING (SOLD BY FOOT)	VARIES
STAINLESS STEEL CORNERS	100057	CORNERS-STAINLESS STEEL,BASE	2
SCREWS - BASE	100064	SCREW,#6X½ PTH SMS SS SCREW	8
ADJUSTABLE METAL SHELF	256935-X	SHELF,ADJ,LASERED METAL,CC/BP UNIT,(COLOR VARIES)	VARIES
ADJUSTABLE SHELF CLIPS	207685	SUPPORT,SHLF,5MM,SINGLE-PIN,L-SHPD	VARIES

**NOTE:**

1. COLOR OF SHELVES VARY WITH MODEL PURCHASED.
  - 1.1. SHELF COLORS:
    - 1.1.1. BLACK, WHITE, CARROT, LIME, AQUA, SILVER, LIGHT GREY, OR DARK GREY.

REV.	DESCRIPTION	DATE	NAME	ECN NO.
A	CREATED DRAWING	8/23/21	EMR	-
REVISION LEVEL				

ALL DIMENSIONS ARE IN INCHES UNLESS NOTED OTHERWISE DECIMALS: X = ± .000 XX = ± .020 XXX = ± .010 ANGLES: = ± 1° CABINET SQUARENESS: = ± .0625	DWN BY: EMR	DATE DWN: 8/23/21
	APR BY:	DATE APR:
	APR BY:	DATE APR:

CONFIDENTIAL:  
ALL DESIGN RIGHTS RESERVED  
THE INFORMATION, DATA, DESIGN, AND DRAWINGS EMBODIED IN THIS DOCUMENT AND ALL REPRODUCTIONS THEREOF ARE THE EXCLUSIVE PROPERTY OF DIVERSIFIED WOODCRAFTS, INC.

THESE DOCUMENTS ARE SUPPLIED WITH THE UNDERSTANDING THAT THEY WILL NOT BE DISCLOSED TO THIRD PARTIES WITHOUT WRITTEN CONSENT OF DIVERSIFIED WOODCRAFTS, INC. ANY REPRODUCTION IN PART OR WHOLE WITHOUT WRITTEN CONSENT IS SUBJECT TO LEGAL ACTION.



300 South Krueger Street  
Suring, WI 54174  
diversifiedwoodcrafts.com

TITLE:  
CUBBY CABINET  
TOOLS AND ASSEMBLY COMPONENTS

DRAWING NUMBER: <b>CC SERIES - METAL SHELF</b>	SCALE: NTS	SHEET: 2 OF 5	REVISION: REV A
---	---------------	------------------	--------------------

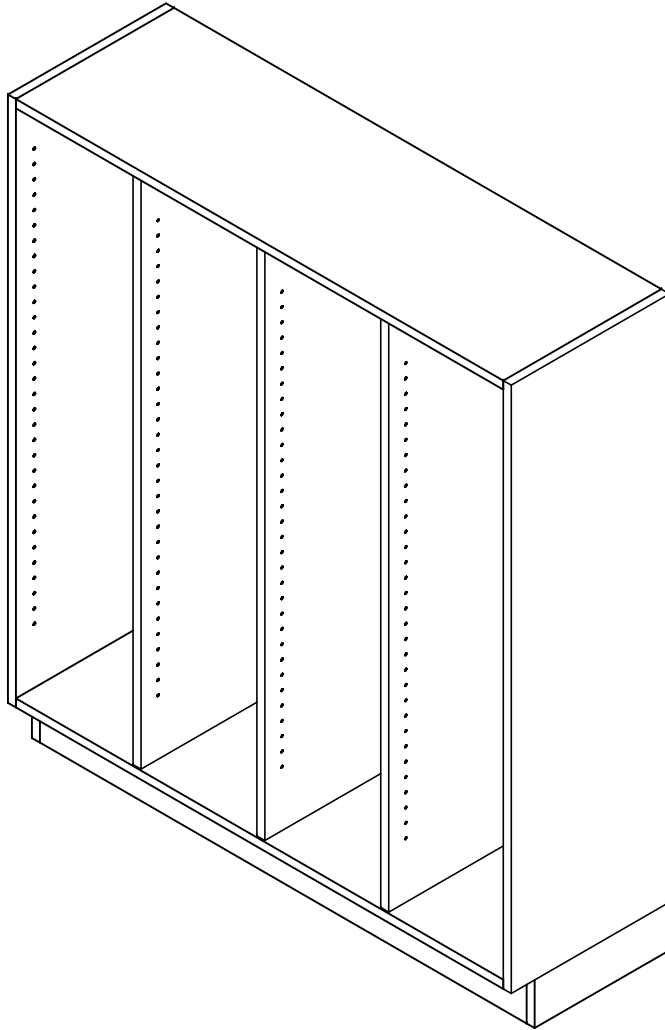

NOTE:

1.

STEP 1:

- POSITION CABINET IN YOUR DESIRED LOCATION.
- LEVEL CABINET.
- ANCHOR TO WALL.

ALL DIMENSIONS ARE IN INCHES UNLESS NOTED OTHERWISE	DWN BY:	EMR	DATE DWN:	8/23/21
DECIMALS: $\times = \pm .000$	APR BY:		DATE APR:	
$_{XX} = \pm .020$	APR BY:		DATE APR:	
$_{XXX} = \pm .010$	APR BY:		DATE APR:	
ANGLES: $= \pm 1^{\circ}0'$	APR BY:		DATE APR:	
CABINET SQUARENESS: $= \pm .0625$	APR BY:		DATE APR:	

CONFIDENTIAL:  
 ALL DESIGN RIGHTS RESERVED  
 THE INFORMATION, DATA, DESIGN, AND DRAWINGS EMBODIED IN THIS DOCUMENT AND ALL REPRODUCTIONS THEREOF ARE THE EXCLUSIVE PROPERTY OF DIVERSIFIED WOODCRAFTS, INC.

THESE DOCUMENTS ARE SUPPLIED WITH THE UNDERSTANDING THAT THEY WILL NOT BE DISCLOSED TO THIRD PARTIES WITHOUT WRITTEN CONSENT OF DIVERSIFIED WOODCRAFTS, INC. ANY REPRODUCTION IN PART OR WHOLE WITHOUT WRITTEN CONSENT IS SUBJECT TO LEGAL ACTION.



300 South Krueger Street  
 Suring, WI 54174  
 diversifiedwoodcrafts.com

TITLE:  
**CUBBY CABINET  
 ASSEMBLY INSTRUCTIONS**

REV.	DESCRIPTION	DATE	NAME	ECN NO.
A	CREATED DRAWING	8/23/21	EMR	-
REVISION LEVEL				

DRAWING NUMBER:	SCALE:	SHEET:	REVISION:
<b>CC SERIES - METAL SHELF</b>	NTS	3 OF 5	REV A

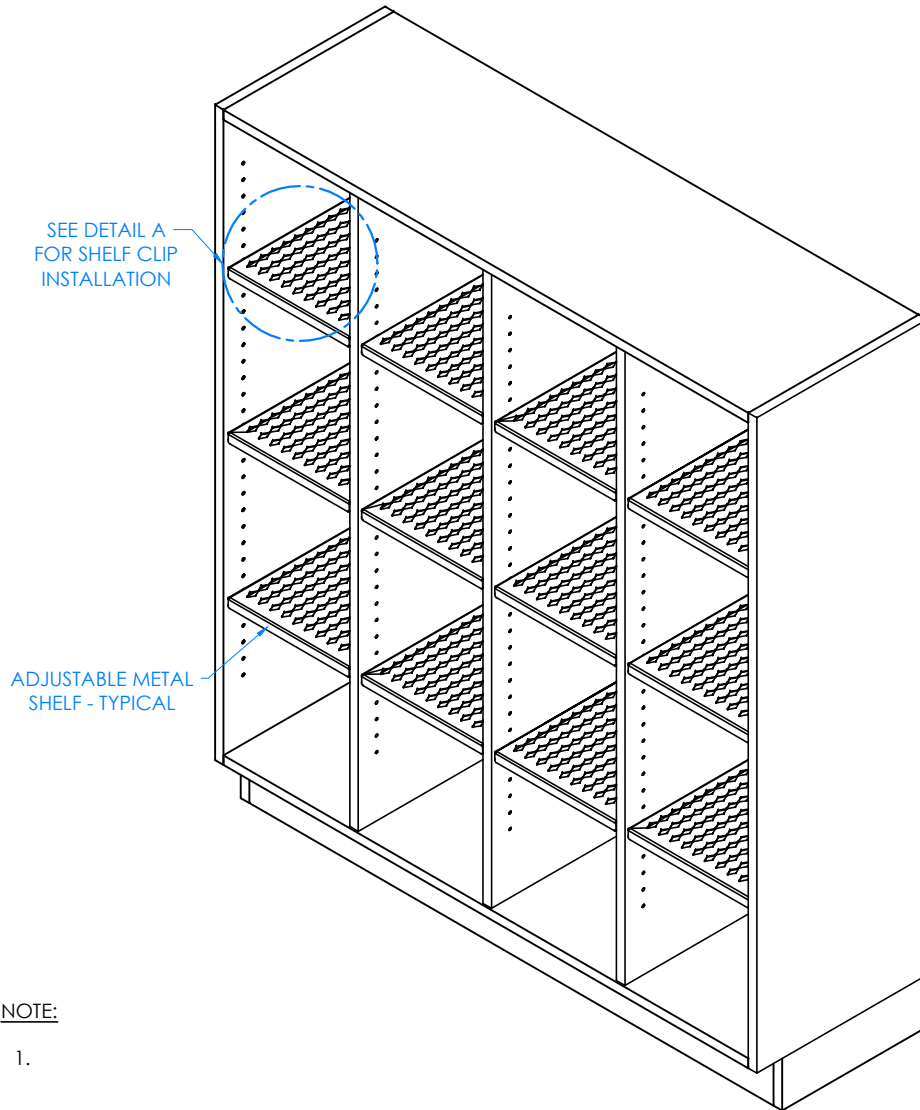

STEP 2:

- INSERT SHELF CLIPS INTO ADJUSTABLE SHELF HOLES LOCATED ON EACH SIDE AND DIVIDERS IN DESIRED LOCATION.
- PLACE ADJUSTABLE SHELVES ONTO SHELF CLIPS.
- MAKE SURE NOTCHES ON SHELVES FIT DIRECTLY OVER SHELF CLIPS.

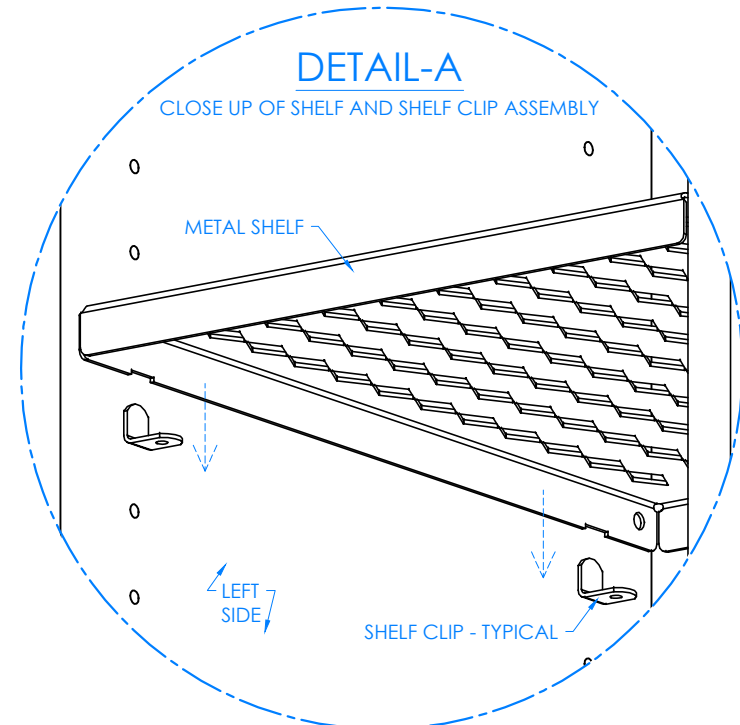

NOTE:

1.

ALL DIMENSIONS ARE IN INCHES UNLESS NOTED OTHERWISE	DWN BY:	EMR	DATE DWN:	8/23/21
DECIMALS: * = ± .000	APR BY:		DATE APR:	
XX = ± .020	APR BY:		DATE APR:	
XXX = ± .010	APR BY:		DATE APR:	
ANGLES: = ± 1°	APR BY:		DATE APR:	
CABINET SQUARENESS: = ± .0625	APR BY:		DATE APR:	

CONFIDENTIAL:  
ALL DESIGN RIGHTS RESERVED  
THE INFORMATION, DATA, DESIGN, AND DRAWINGS EMBODIED IN THIS DOCUMENT AND ALL REPRODUCTIONS THEREOF ARE THE EXCLUSIVE PROPERTY OF DIVERSIFIED WOODCRAFTS, INC.

THESE DOCUMENTS ARE SUPPLIED WITH THE UNDERSTANDING THAT THEY WILL NOT BE DISCLOSED TO THIRD PARTIES WITHOUT WRITTEN CONSENT OF DIVERSIFIED WOODCRAFTS, INC. ANY REPRODUCTION IN PART OR WHOLE WITHOUT WRITTEN CONSENT IS SUBJECT TO LEGAL ACTION.



300 South Krueger Street  
Suring, WI 54174  
diversifiedwoodcrafts.com

TITLE:  
**CUBBY CABINET  
ASSEMBLY INSTRUCTIONS**

REV.	DESCRIPTION	DATE	NAME	ECN NO.
A	CREATED DRAWING	8/23/21	EMR	-
REVISION LEVEL				

DRAWING NUMBER:	SCALE:	SHEET:	REVISION:
<b>CC SERIES - METAL SHELF</b>	NTS	4 OF 5	REV A

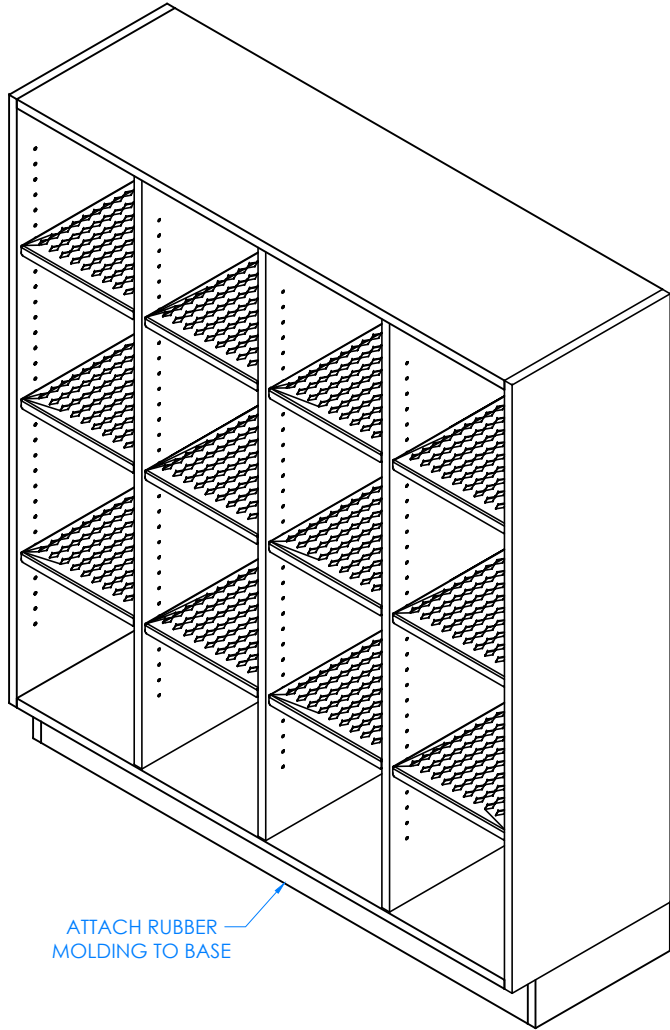

STEP 3:

- ATTACH RUBBER MOLDING TO BASE OF CABINET USING CONTACT CEMENT.
- SCREW STAINLESS STEEL CORNER BRACKETS ON EACH CORNER OVER THE BASE MOLDING WITH HARDWARE PROVIDED.

NOTE:

1.

ATTACH RUBBER MOLDING TO BASE

COMPLETE UNIT SHOWN

ALL DIMENSIONS ARE IN INCHES UNLESS NOTED OTHERWISE	DWN BY:	EMR	DATE DWN:	8/23/21
DECIMALS: $\times = \pm .000$	APR BY:		DATE APR:	
$_{XX} = \pm .020$	APR BY:		DATE APR:	
$_{XXX} = \pm .010$	APR BY:		DATE APR:	
ANGLES: $= \pm 1^{\circ}0'$	APR BY:		DATE APR:	
CABINET SQUARENESS: $= \pm .0625$	APR BY:		DATE APR:	

CONFIDENTIAL:  
ALL DESIGN RIGHTS RESERVED  
THE INFORMATION, DATA, DESIGN, AND DRAWINGS EMBODIED IN THIS DOCUMENT AND ALL REPRODUCTIONS THEREOF ARE THE EXCLUSIVE PROPERTY OF DIVERSIFIED WOODCRAFTS, INC.

THESE DOCUMENTS ARE SUPPLIED WITH THE UNDERSTANDING THAT THEY WILL NOT BE DISCLOSED TO THIRD PARTIES WITHOUT WRITTEN CONSENT OF DIVERSIFIED WOODCRAFTS, INC. ANY REPRODUCTION IN PART OR WHOLE WITHOUT WRITTEN CONSENT IS SUBJECT TO LEGAL ACTION.



300 South Krueger Street  
Suring, WI 54174  
diversifiedwoodcrafts.com

TITLE:  
CUBBY CABINET  
ASSEMBLY INSTRUCTIONS

REV.	DESCRIPTION	DATE	NAME	ECN NO.
A	CREATED DRAWING	8/23/21	EMR	-
REVISION LEVEL				

DRAWING NUMBER:	SCALE:	SHEET:	REVISION:
CC SERIES - METAL SHELF	NTS	5 OF 5	REV A