

# WORK DESK

## CT-200 SERIES ASSEMBLY INSTRUCTIONS

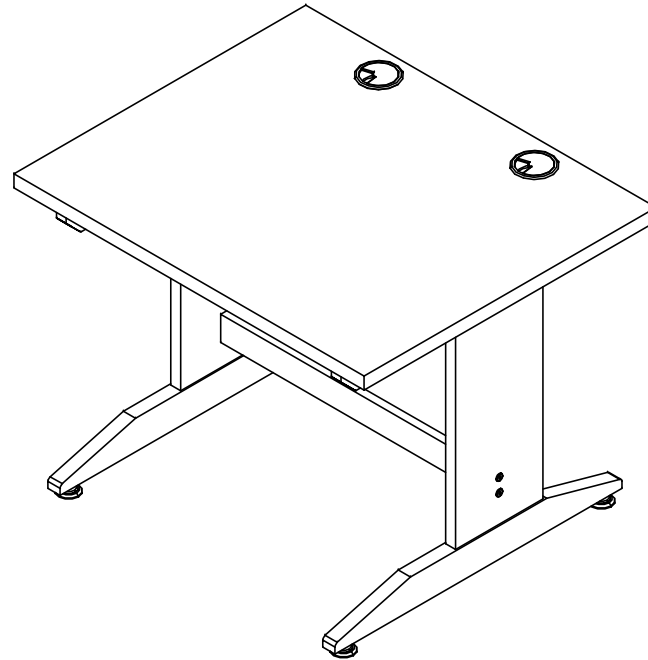

**NOTE:**

1. MODEL VIEWS MAY NOT REPRESENT EXACT MODEL PURCHASED

DWN BY:	EMK	DWN DATE:	1/27/14
APR BY:		DATE APR:	
APR BY:		DATE APR:	

UNLESS OTHERWISE SPECIFIED  
DIMENSION ARE IN INCHES  
CABINET SQUARENESS ± .0625  
FRACTIONAL VALUES ± 1/32"  
- ALL VALUES ± OVERALL -



300 South Krueger Street  
Suring, WI 54174  
diversifiedwoodcrafts.com

TITLE:  
**WORK DESK  
ASSEMBLY INSTRUCTIONS**

REV.	DESCRIPTION	DATE	NAME	ECH NO.
A	CREATED ASSEMBLY INSTRUCTIONS	1/27/14	EMK	-
REVISION LEVEL				

THIS DRAWING IS THE SOLE PROPERTY OF  
DIVERSIFIED WOOD CRAFTS. IT MAY NOT  
BE ALTERED OR CHANGED WITHOUT  
PERMISSION

DRAWING NUMBER:  
**CT-200 SERIES**

SCALE:	SHEET:	REVISION:
NTS	1 OF 3	REV A

## TOOLS REQUIRED

4MM ALLEN WRENCH

#2 PHILLIPS SCREW DRIVER

## ASSEMBLY COMPONENTS

ITEMS INCLUDED	PART #	PART DESCRIPTION	QTY
TOP	VARIES	TOP-VARIES WITH TABLE STYLE	1
CONFIRMATS-STRETCHER	237959	SCREW,7MMX70MM,CONN,ALLENHEAD, BLACK	4
SCREWS-TOP	227831	SCREW,# 10X2.50 PHIL PAN SMS,ZINC	6
LEG LEVELERS	100079	LEG LEVELERS,BLK,BASE 1	4
GROMMETS	100767	GROMMETS,3.125,BLK	2
LEG PANEL ASSEMBLY	234117	LEG,CT,PANEL,PED,ASSY,27 HIGH	2
STRETCHER	N/A	STRETCHER-SIZE VARIES WITH TABLE STYLE	1

**NOTE:**

1.

DWN BY:	EMK	DWN DATE:	1/27/14
APR BY:		DATE APR:	
APR BY:		DATE APR:	

UNLESS OTHERWISE SPECIFIED  
DIMENSION ARE IN INCHES  
CABINET SQUARENESS ± .0625  
FRACTIONAL VALUES ± 1/32"  
- ALL VALUES ± OVERALL -



300 South Krueger Street  
Suring, WI 54174  
diversifiedwoodcrafts.com

TITLE:  
WORK DESK  
TOOLS AND ASSEMBLY COMPONENTS

REV.	DESCRIPTION	DATE	NAME	ECH NO.
A	CREATED ASSEMBLY INSTRUCTIONS	1/27/14	EMK	-
				REVISION LEVEL

THIS DRAWING IS THE SOLE PROPERTY OF  
DIVERSIFIED WOOD CRAFTS. IT MAY NOT  
BE ALTERED OR CHANGED WITHOUT  
PERMISSION

DRAWING NUMBER:	SCALE:	SHEET:	REVISION:
CT-200 SERIES	NTS	2 OF 3	REV A

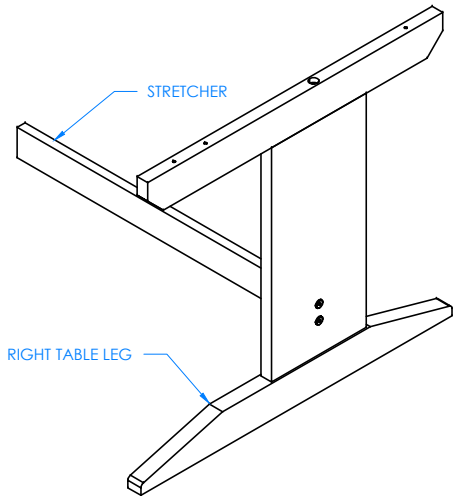

**STEP 1:**  
TAKE THE RIGHT TABLE LEG AND INSERT THE STRETCHER THROUGH THE PREDRILLED HOLES. ATTACH WITH CONFIRMATS PROVIDED.

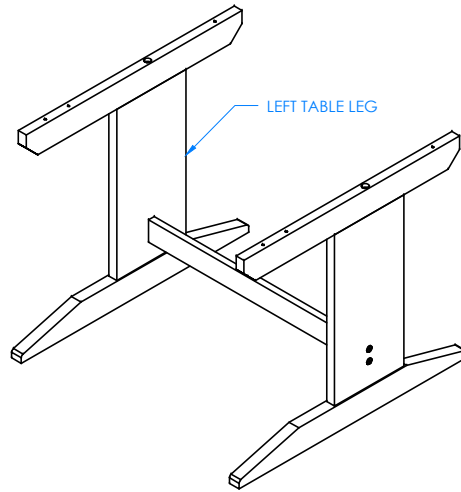

**STEP 2:**  
WITH THE LEFT TABLE LEG, REPEAT STEP ONE. MAKE SURE EACH CONFIRMAT IS TIGHT AND STRETCHER IS STRAIGHT.

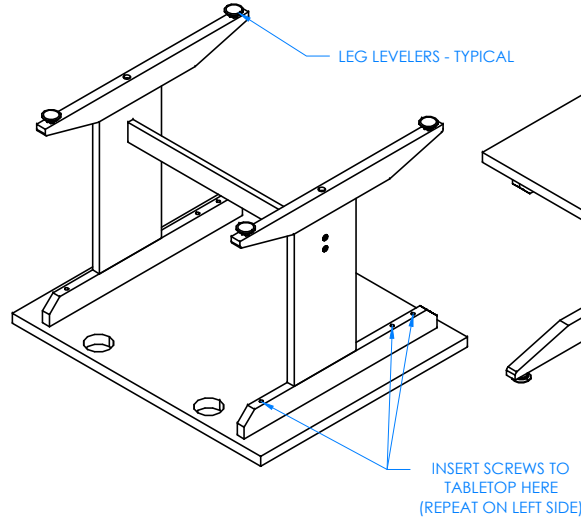

**STEP 3:**  
FLIP LEG ASSEMBLY OVER AND CENTER LEGS ONTO TOP. MAKE SURE TOP IS SET ON A CLEAN SURFACE SO YOU DON'T DAMAGE THE TABLETOP. ATTACH THE LEGS TO THE TOP USING THE SCREWS PROVIDED. SCREW LEG LEVELERS INTO T-NUT IN BOTTOM OF THE LEG.

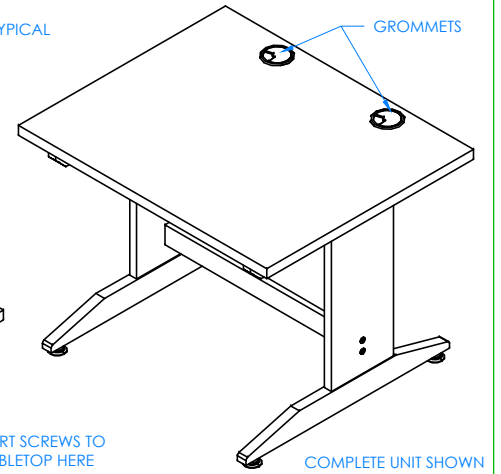

**STEP 4:**  
TURN TABLE OVER AND ADJUST THE LEG LEVELERS TO LEVEL THE TABLE. INSERT GROMMETS TO TOP.

**NOTE:**

- 1.

DWN BY:	EMK	DWN DATE:	1/27/14
APR BY:		DATE APR:	
APR BY:		DATE APR:	

UNLESS OTHERWISE SPECIFIED  
DIMENSION ARE IN INCHES  
CABINET SQUARENESS ± .0625  
FRACTIONAL VALUES ± 1/32"  
- ALL VALUES ± OVERALL -



300 South Krueger Street  
Suring, WI 54174  
diversifiedwoodcrafts.com

TITLE:  
**WORK DESK  
ASSEMBLY INSTRUCTIONS**

REV.	DESCRIPTION	DATE	NAME	ECH NO.
A	CREATED ASSEMBLY INSTRUCTIONS	1/27/14	EMK	-
REVISION LEVEL				

THIS DRAWING IS THE SOLE PROPERTY OF  
DIVERSIFIED WOOD CRAFTS. IT MAY NOT  
BE ALTERED OR CHANGED WITHOUT  
PERMISSION

DRAWING NUMBER:	SCALE:	SHEET:	REVISION:
<b>CT-200 SERIES</b>	NTS	3 OF 3	REV A