

DRAWER BASE DRAWING TABLE - TWO PIECE TOP

DT-4SA & DT-8A
ASSEMBLY INSTRUCTIONS

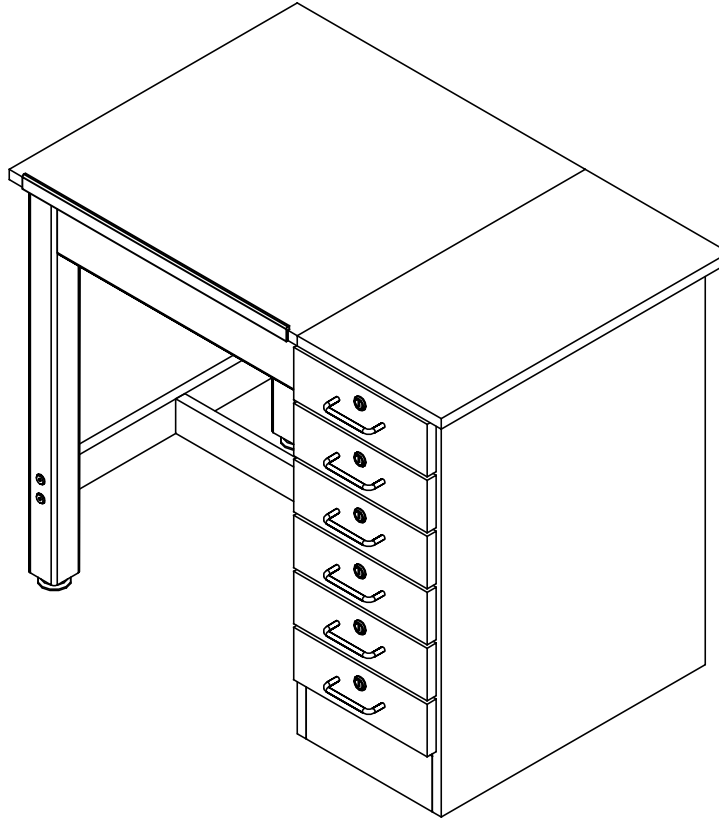

NOTE:

1. MODEL VIEWS MAY NOT REPRESENT EXACT MODEL PURCHASED

ALL DIMENSIONS ARE IN INCHES UNLESS NOTED OTHERWISE
 DECIMALS: X = ± .020
 XX = ± .020
 XXX = ± .010
 ANGLES: = ± 1°
 CABINET SQUARENESS: = ± .0625

DWN BY:	EMR	DATE DWN:	3/23/20
APR BY:		DATE APR:	
APR BY:		DATE APR:	

CONFIDENTIAL:
 ALL DESIGN RIGHTS RESERVED
 THE INFORMATION, DATA, DESIGN, AND DRAWINGS EMBODIED IN THIS DOCUMENT AND ALL REPRODUCTIONS THEREOF ARE THE EXCLUSIVE PROPERTY OF DIVERSIFIED WOODCRAFTS, INC.

THESE DOCUMENTS ARE SUPPLIED WITH THE UNDERSTANDING THAT THEY WILL NOT BE DISCLOSED TO THIRD PARTIES WITHOUT WRITTEN CONSENT OF DIVERSIFIED WOODCRAFTS, INC. ANY REPRODUCTION IN PART OR WHOLE WITHOUT WRITTEN CONSENT IS SUBJECT TO LEGAL ACTION.



300 South Krueger Street
 Suring, WI 54174
 diversifiedwoodcrafts.com

TITLE:
 DRAWER BASE DRAWING TABLE - TWO PIECE TOP
 ASSEMBLY INSTRUCTIONS

DRAWING NUMBER:	SCALE:	SHEET:	REVISION:
DT-4SA & DT-8A	NTS	1 OF 10	REV A

REV.	DESCRIPTION	DATE	NAME	ECN NO.
A	CREATED ASSEMBLY INSTRUCTIONS	3/23/20	EMR	-
REVISION LEVEL				

TOOLS REQUIRED

1/2" WRENCH
1/2" SOCKET AND TORQUE WRENCH - OPTIONAL
4MM ALLEN WRENCH

ASSEMBLY COMPONENTS

ITEMS INCLUDED	PART #	PART DESCRIPTION	QTY
TOP AND APRON ASSEMBLY	N/A	TOP ASSEMBLY (FACTORY ASSEMBLED)	1
CABINET	N/A	CABINET - SIZE VARIES	1
LEGS	VARIES	LEG,MPL - HEIGHT VARIES	2
LEG HARDWARE	520001	LEG HARDWARE KIT, 1 LEG	2
LEG BRACE	N/A	LEG BRACE - SIZE VARIES	1
STRETCHER	N/A	STRETCHER - 20.75" LONG	1
CONFIRMATS - LEGS	227578	SCREW,7MMX90MM,CONN,ALLENHEAD, BLACK	4
CONFIRMATS - STRETCHER	228564	SCREW,7MMX50MM,CONN,ALLENHEAD, BLACK	4
BOLT - INTERNAL APRON	231922	BOLT,3/8 -16 X 1.625 HEX HEAD	2
WASHER - INTERNAL APRON	100451	WASHER, 5/16 FLAT ZINC PLATED	2
PENCIL LEDGE	14-0027	PENCIL LEDGE - 22"	1
SCREWS - PENCIL LEDGE	236263	SCREW,#6X3/4 TRUSS HEAD,QUAD BLACK	6

NOTE:

1.

ALL DIMENSIONS ARE IN INCHES UNLESS NOTED OTHERWISE DECIMALS: X = ± .030 XX = ± .020 XXX = ± .010 ANGLES: = ± 1° CABINET SQUARENESS = ± .0625	DWN BY: EMR	DATE DWN: 3/23/20
	APR BY:	DATE APR:
	APR BY:	DATE APR:

CONFIDENTIAL:
ALL DESIGN RIGHTS RESERVED
THE INFORMATION, DATA, DESIGN, AND DRAWINGS EMBODIED IN THIS DOCUMENT AND ALL REPRODUCTIONS THEREOF ARE THE EXCLUSIVE PROPERTY OF DIVERSIFIED WOODCRAFTS, INC.

THESE DOCUMENTS ARE SUPPLIED WITH THE UNDERSTANDING THAT THEY WILL NOT BE DISCLOSED TO THIRD PARTIES WITHOUT WRITTEN CONSENT OF DIVERSIFIED WOODCRAFTS, INC. ANY REPRODUCTION IN PART OR WHOLE WITHOUT WRITTEN CONSENT IS SUBJECT TO LEGAL ACTION.



300 South Krueger Street
Suring, WI 54174
diversifiedwoodcrafts.com

TITLE:
DRAWER BASE DRAWING TABLE - TWO PIECE TOP
TOOLS AND ASSEMBLY COMPONENTS

DRAWING NUMBER: DT-4SA & DT-8A	SCALE: NTS	SHEET: 2 OF 10	REVISION: REV A
-----------------------------------	---------------	-------------------	--------------------

REV.	DESCRIPTION	DATE	NAME	ECN NO.
A	CREATED ASSEMBLY INSTRUCTIONS	3/23/20	EMR	-
REVISION LEVEL				

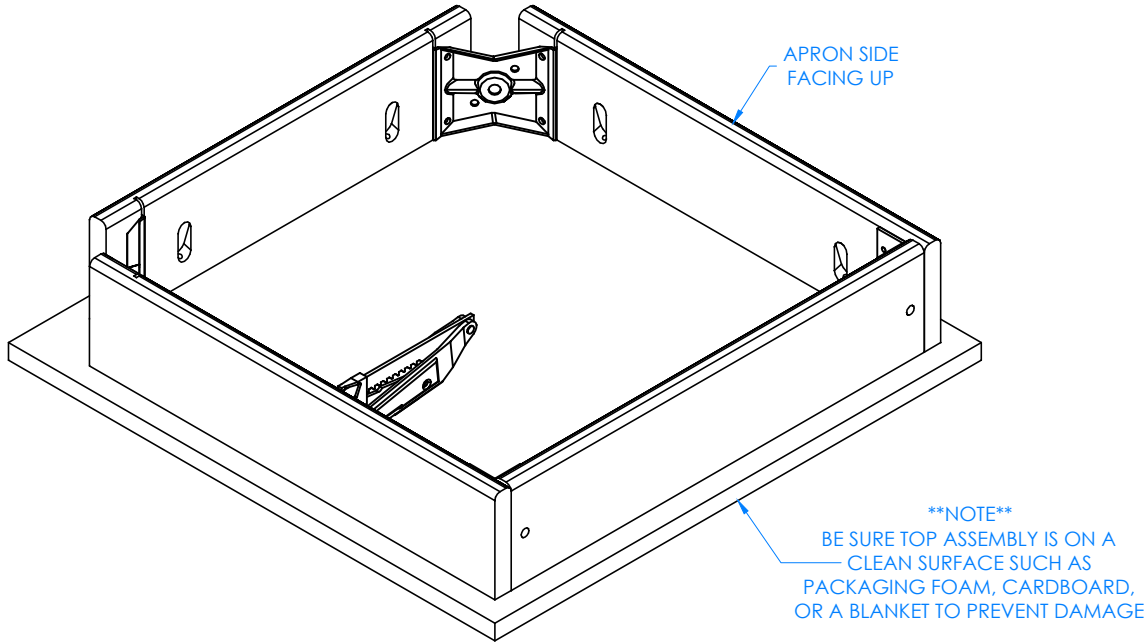

STEP 1:

- LAY APRON ASSEMBLY ON FLOOR WITH APRON SIDE FACING UP.

NOTE:

1.

ALL DIMENSIONS ARE IN INCHES UNLESS NOTED OTHERWISE	DWN BY:	EMR	DATE DWN:	3/23/20
DECIMALS: $\frac{1}{16}$ = ± .030	APR BY:		DATE APR:	
XX = ± .020	APR BY:		DATE APR:	
.XXX = ± .010	APR BY:		DATE APR:	
ANGLES: = ± 1°	APR BY:		DATE APR:	
CABINET SQUARENESS: = ± .0625	APR BY:		DATE APR:	

CONFIDENTIAL:
 ALL DESIGN RIGHTS RESERVED
 THE INFORMATION, DATA, DESIGN, AND DRAWINGS EMBODIED IN THIS DOCUMENT AND ALL REPRODUCTIONS THEREOF ARE THE EXCLUSIVE PROPERTY OF DIVERSIFIED WOODCRAFTS, INC.

THESE DOCUMENTS ARE SUPPLIED WITH THE UNDERSTANDING THAT THEY WILL NOT BE DISCLOSED TO THIRD PARTIES WITHOUT WRITTEN CONSENT OF DIVERSIFIED WOODCRAFTS, INC. ANY REPRODUCTION IN PART OR WHOLE WITHOUT WRITTEN CONSENT IS SUBJECT TO LEGAL ACTION.



300 South Krueger Street
 Suring, WI 54174
 diversifiedwoodcrafts.com

TITLE:
 DRAWER BASE DRAWING TABLE - TWO PIECE TOP ASSEMBLY INSTRUCTIONS

REV.	DESCRIPTION	DATE	NAME	ECN NO.
A	CREATED ASSEMBLY INSTRUCTIONS	3/23/20	EMR	-

REVISION LEVEL

DRAWING NUMBER:	SCALE:	SHEET:	REVISION:
DT-4SA & DT-8A	NTS	3 OF 10	REV A

INSERT HANGER BOLT THROUGH HERE WITH LOCK WASHER AND HEX NUT

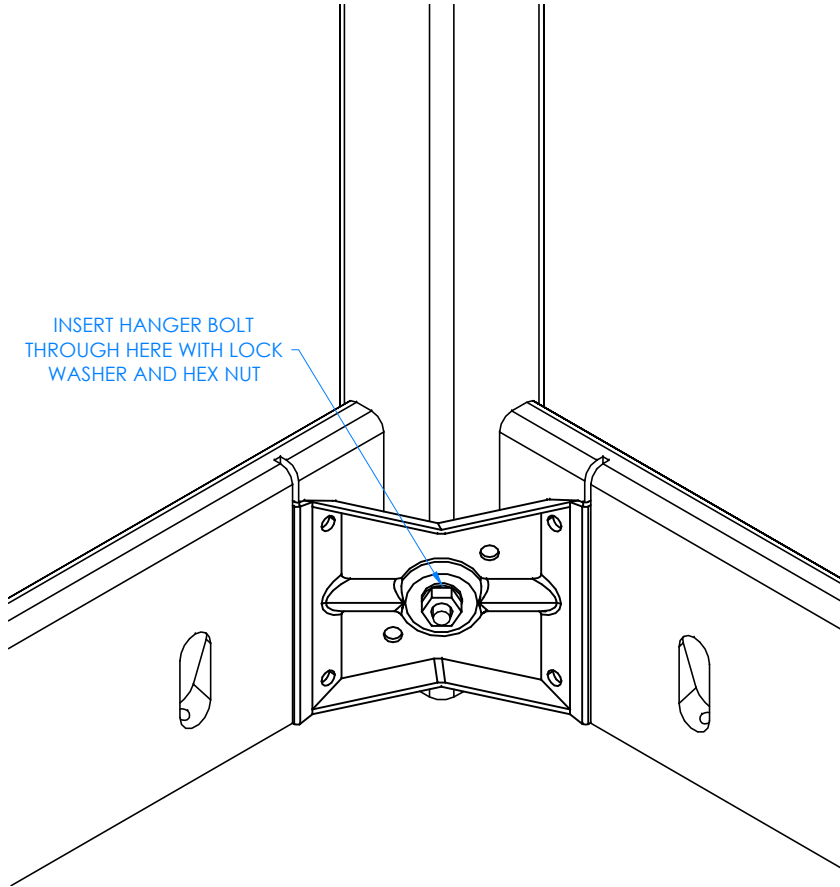

CLOSE UP OF CORNER LEG ASSEMBLY

STEP 2:

- INSERT HANGER BOLT ON ONE LEG THROUGH THE CORNER BRACKET AND INSERT LOCK WASHER AND HEX NUT.
- SCREW ON NUT USING A 1/2" WRENCH OR 1/2" SOCKET AND TORQUE WRENCH.
- DO NOT TIGHTEN ALL THE WAY.
- REPEAT FOR THE OTHER LEG.
- THE LEG WITH A CHAMFER MUST GO ON THE FRONT OF THE TABLE WITH CHAMFERED EDGE FACING OUT.

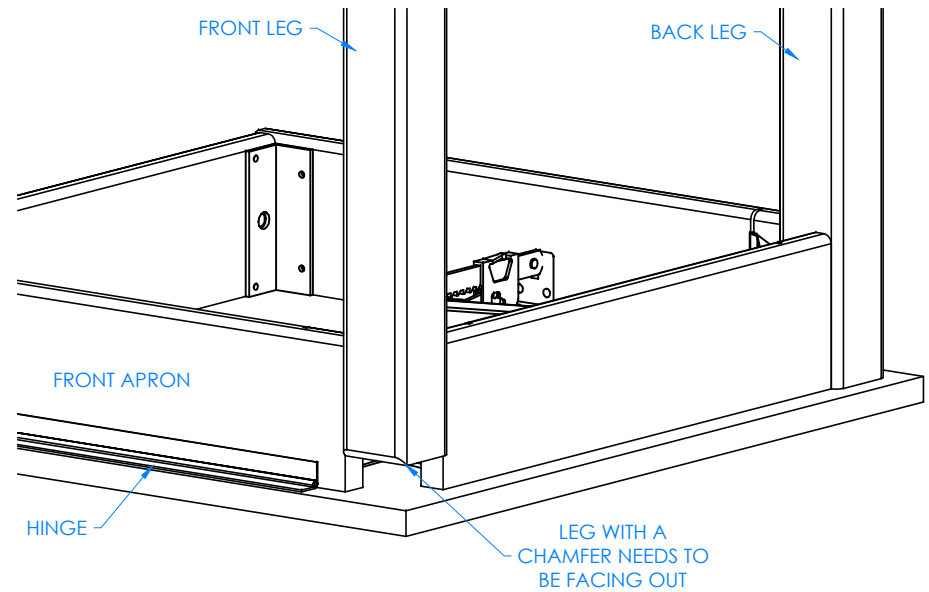

CLOSE UP OF LEG WITH A CHAMFER

NOTE:

1.

ALL DIMENSIONS ARE IN INCHES UNLESS NOTED OTHERWISE	DWN BY:	EMR	DATE DWN:	3/23/20
DECIMALS: .X = ± .030 .XX = ± .020 .XXX = ± .010	APR BY:		DATE APR:	
ANGLES: = ± 1°	APR BY:		DATE APR:	
CABINET SQUARENESS: = ± .0625				

CONFIDENTIAL:
ALL DESIGN RIGHTS RESERVED
THE INFORMATION, DATA, DESIGN, AND DRAWINGS EMBODIED IN THIS DOCUMENT AND ALL REPRODUCTIONS THEREOF ARE THE EXCLUSIVE PROPERTY OF DIVERSIFIED WOODCRAFTS, INC.

THESE DOCUMENTS ARE SUPPLIED WITH THE UNDERSTANDING THAT THEY WILL NOT BE DISCLOSED TO THIRD PARTIES WITHOUT WRITTEN CONSENT OF DIVERSIFIED WOODCRAFTS, INC. ANY REPRODUCTION IN PART OR WHOLE WITHOUT WRITTEN CONSENT IS SUBJECT TO LEGAL ACTION.



300 South Krueger Street
Suring, WI 54174
diversifiedwoodcrafts.com

TITLE:
DRAWER BASE DRAWING TABLE - TWO PIECE TOP
ASSEMBLY INSTRUCTIONS

REV.	DESCRIPTION	DATE	NAME	ECN NO.
A	CREATED ASSEMBLY INSTRUCTIONS	3/23/20	EMR	-

REVISION LEVEL

DRAWING NUMBER:	SCALE:	SHEET:	REVISION:
DT-4SA & DT-8A	NTS	4 OF 10	REV A

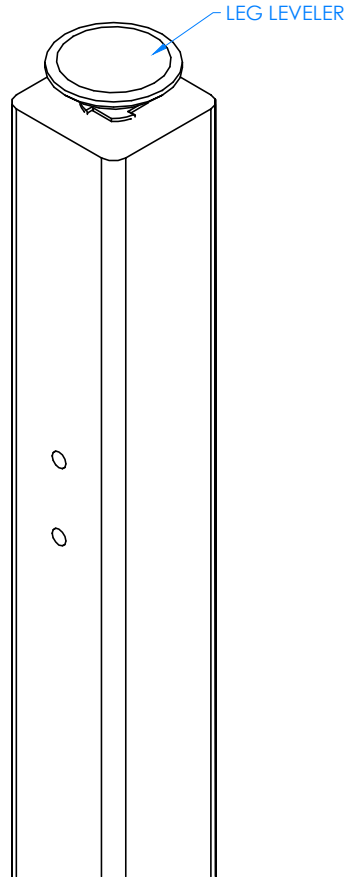

CLOSE UP OF LEG LEVELER ASSEMBLY

STEP 3:

- SCREW LEG LEVELERS INTO T-NUT ON BOTTOM OF LEGS.

NOTE:

1.

ALL DIMENSIONS ARE IN INCHES UNLESS NOTED OTHERWISE	DWN BY:	EMR	DATE DWN:	3/23/20
DECIMALS: $\frac{X}{1000}$ = ± .000	APR BY:		DATE APR:	
XX = ± .020	APR BY:		DATE APR:	
.XXX = ± .010	APR BY:		DATE APR:	
ANGLES: = ± 1°	APR BY:		DATE APR:	
CABINET SQUARENESS: = ± .0625	APR BY:		DATE APR:	

CONFIDENTIAL:
 ALL DESIGN RIGHTS RESERVED
 THE INFORMATION, DATA, DESIGN, AND DRAWINGS EMBODIED IN THIS DOCUMENT AND ALL REPRODUCTIONS THEREOF ARE THE EXCLUSIVE PROPERTY OF DIVERSIFIED WOODCRAFTS, INC.

THESE DOCUMENTS ARE SUPPLIED WITH THE UNDERSTANDING THAT THEY WILL NOT BE DISCLOSED TO THIRD PARTIES WITHOUT WRITTEN CONSENT OF DIVERSIFIED WOODCRAFTS, INC. ANY REPRODUCTION IN PART OR WHOLE WITHOUT WRITTEN CONSENT IS SUBJECT TO LEGAL ACTION.



300 South Krueger Street
 Suring, WI 54174
 diversifiedwoodcrafts.com

TITLE:
 DRAWER BASE DRAWING TABLE - TWO PIECE TOP
 ASSEMBLY INSTRUCTIONS

REV.	DESCRIPTION	DATE	NAME	ECN NO.
A	CREATED ASSEMBLY INSTRUCTIONS	3/23/20	EMR	-

REVISION LEVEL

DRAWING NUMBER:	SCALE:	SHEET:	REVISION:
DT-4SA & DT-8A	NTS	5 OF 10	REV A

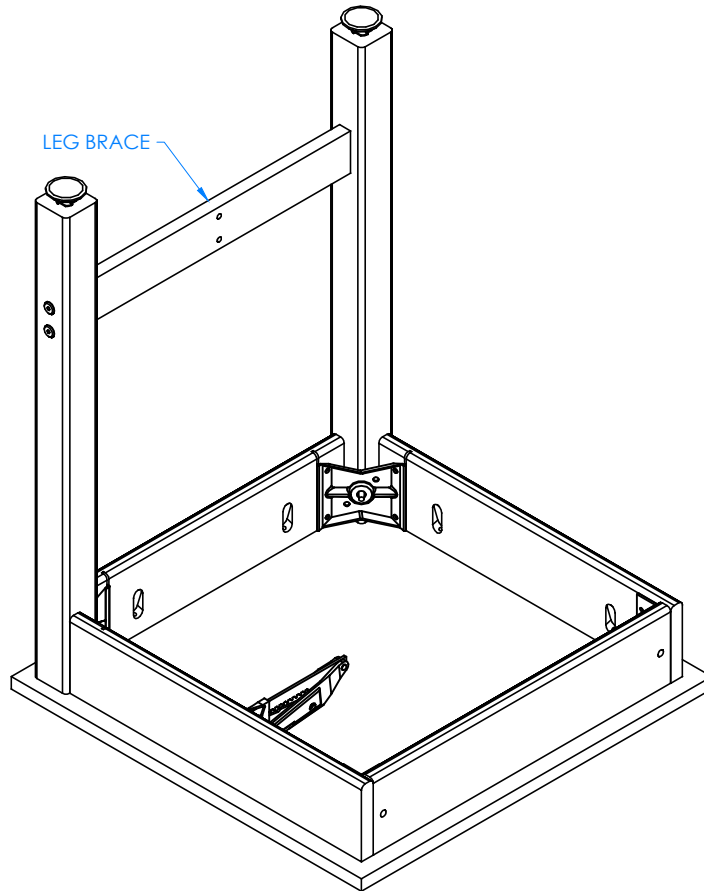

STEP 4:

- ATTACH BRACE TO LEGS
- INSERT CONFIRMATS INTO ONE LEG AND SCREW INTO BRACE.
- REPEAT FOR THE OTHER LEG.
- MAKE SURE BRACE IS STRAIGHT AND ALL CONFIRMATS ARE SECURE.

NOTE:

1.

ALL DIMENSIONS ARE IN INCHES UNLESS NOTED OTHERWISE	DWN BY:	EMR	DATE DWN:	3/23/20
DECIMALS: .X = ± .030 .XX = ± .020 .XXX = ± .010	APR BY:		DATE APR:	
ANGLES: = ± 1° CABINET SQUARENESS = ± .0625	APR BY:		DATE APR:	

CONFIDENTIAL:
ALL DESIGN RIGHTS RESERVED
THE INFORMATION, DATA, DESIGN, AND DRAWINGS EMBODIED IN THIS DOCUMENT AND ALL REPRODUCTIONS THEREOF ARE THE EXCLUSIVE PROPERTY OF DIVERSIFIED WOODCRAFTS, INC.

THESE DOCUMENTS ARE SUPPLIED WITH THE UNDERSTANDING THAT THEY WILL NOT BE DISCLOSED TO THIRD PARTIES WITHOUT WRITTEN CONSENT OF DIVERSIFIED WOODCRAFTS, INC. ANY REPRODUCTION IN PART OR WHOLE WITHOUT WRITTEN CONSENT IS SUBJECT TO LEGAL ACTION.



300 South Krueger Street
Suring, WI 54174
diversifiedwoodcrafts.com

TITLE:
DRAWER BASE DRAWING TABLE - TWO PIECE TOP
ASSEMBLY INSTRUCTIONS

REV.	DESCRIPTION	DATE	NAME	ECN NO.
A	CREATED ASSEMBLY INSTRUCTIONS	3/23/20	EMR	-
REVISION LEVEL				

DRAWING NUMBER:	SCALE:	SHEET:	REVISION:
DT-4SA & DT-8A	NTS	6 OF 10	REV A

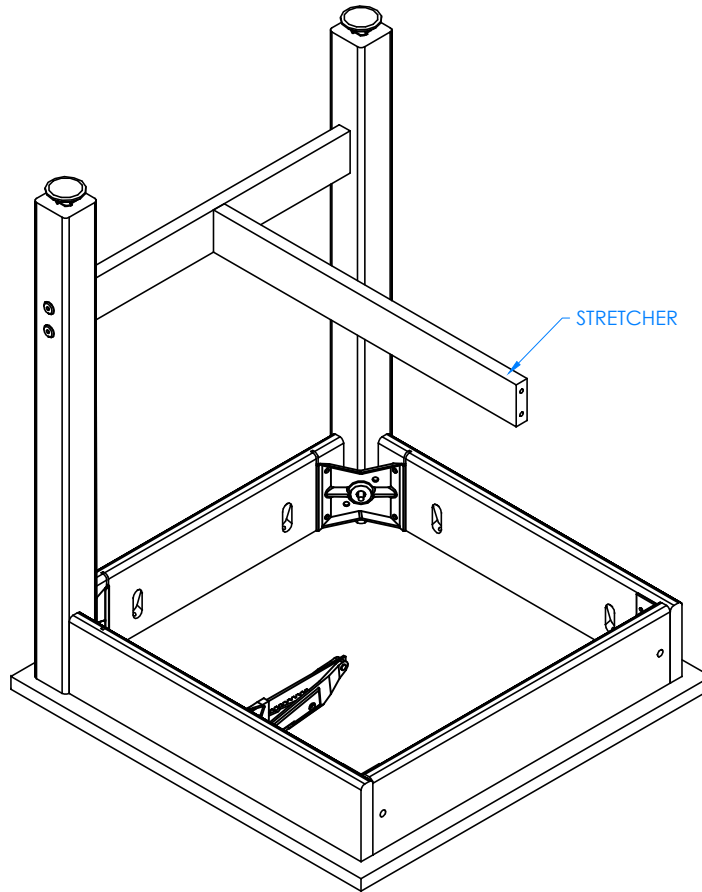

STEP 5:

- ATTACH STRETCHER TO BRACE WITH HARDWARE PROVIDED.
- GO BACK TO STEP 2 AND TIGHTEN UP THE HANGER BOLTS FOR EACH LEG USING A 1/2" WRENCH OR 1/2" SOCKET AND TORQUE WRENCH, TO A MINIMUM OF 12FT LBS BUT NOT TO EXCEED 17FT LBS.

NOTE:

1.

ALL DIMENSIONS ARE IN INCHES UNLESS NOTED OTHERWISE	DWN BY:	EMR	DATE DWN:	3/23/20
DECIMALS: X = ± .030	APR BY:		DATE APR:	
XX = ± .020	APR BY:		DATE APR:	
XXX = ± .010	APR BY:		DATE APR:	
ANGLES: = ± 1°	APR BY:		DATE APR:	
CABINET SQUARENESS: = ± .0625	APR BY:		DATE APR:	

CONFIDENTIAL:
 ALL DESIGN RIGHTS RESERVED
 THE INFORMATION, DATA, DESIGN, AND DRAWINGS EMBODIED IN THIS DOCUMENT AND ALL REPRODUCTIONS THEREOF ARE THE EXCLUSIVE PROPERTY OF DIVERSIFIED WOODCRAFTS, INC.

THESE DOCUMENTS ARE SUPPLIED WITH THE UNDERSTANDING THAT THEY WILL NOT BE DISCLOSED TO THIRD PARTIES WITHOUT WRITTEN CONSENT OF DIVERSIFIED WOODCRAFTS, INC. ANY REPRODUCTION IN PART OR WHOLE WITHOUT WRITTEN CONSENT IS SUBJECT TO LEGAL ACTION.



300 South Krueger Street
 Suring, WI 54174
 diversifiedwoodcrafts.com

TITLE:
DRAWER BASE DRAWING TABLE - TWO PIECE TOP ASSEMBLY INSTRUCTIONS

REV.	DESCRIPTION	DATE	NAME	ECN NO.
A	CREATED ASSEMBLY INSTRUCTIONS	3/23/20	EMR	-
REVISION LEVEL				

DRAWING NUMBER:	SCALE:	SHEET:	REVISION:
DT-4SA & DT-8A	NTS	7 OF 10	REV A

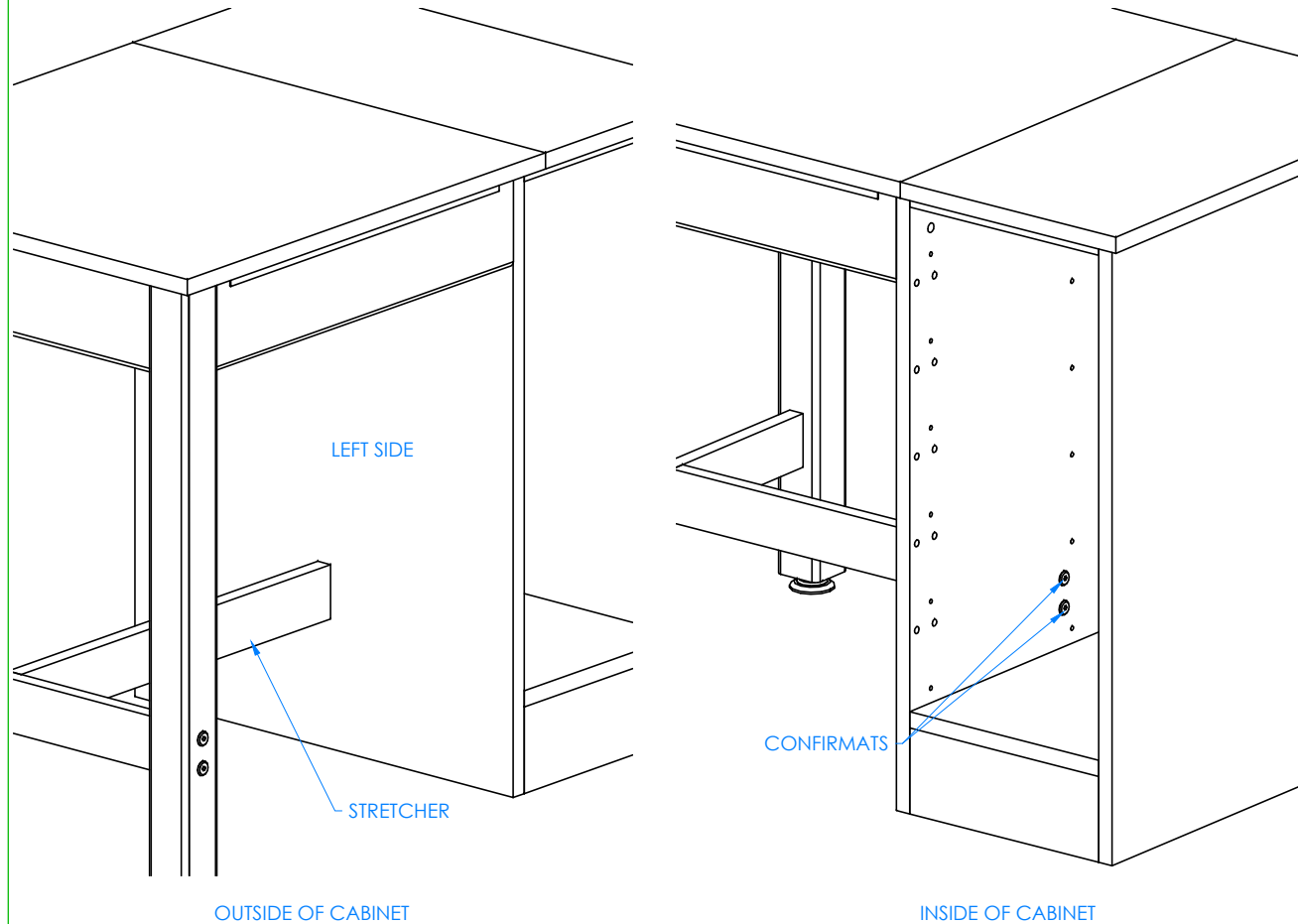

STEP 6:

- FLIP APRON ASSEMBLY OVER ONTO LEGS.
- ALIGN HOLES ON STRETCHER TO HOLES ON LEFT SIDE OF CABINET.
- TAKE OUT DRAWERS TO ATTACH STRETCHER FROM INSIDE THE CABINET.
- ATTACH TO CABINET WITH HARDWARE PROVIDED.

NOTE:

1.

DRAWERS AND HARDWARE REMOVED FOR CLARITY

ALL DIMENSIONS ARE IN INCHES UNLESS NOTED OTHERWISE			
DECIMALS:	X = ± .030	DWN BY:	EMR
	XX = ± .020	DATE DWN:	3/23/20
	XXX = ± .010	APR BY:	
ANGLES:	= ± 1°	DATE APR:	
CABINET SQUARENESS:	= ± .0625	APR BY:	

CONFIDENTIAL:
ALL DESIGN RIGHTS RESERVED
THE INFORMATION, DATA, DESIGN, AND DRAWINGS EMBODIED IN THIS DOCUMENT AND ALL REPRODUCTIONS THEREOF ARE THE EXCLUSIVE PROPERTY OF DIVERSIFIED WOODCRAFTS, INC.

THESE DOCUMENTS ARE SUPPLIED WITH THE UNDERSTANDING THAT THEY WILL NOT BE DISCLOSED TO THIRD PARTIES WITHOUT WRITTEN CONSENT OF DIVERSIFIED WOODCRAFTS, INC. ANY REPRODUCTION IN PART OR WHOLE WITHOUT WRITTEN CONSENT IS SUBJECT TO LEGAL ACTION.



300 South Krueger Street
Suring, WI 54174
diversifiedwoodcrafts.com

TITLE:
DRAWER BASE DRAWING TABLE - TWO PIECE TOP
ASSEMBLY INSTRUCTIONS

REV.	DESCRIPTION	DATE	NAME	ECN NO.
A	CREATED ASSEMBLY INSTRUCTIONS	3/23/20	EMR	-

REVISION LEVEL

DRAWING NUMBER:	SCALE:	SHEET:	REVISION:
DT-4SA & DT-8A	NTS	8 OF 10	REV A

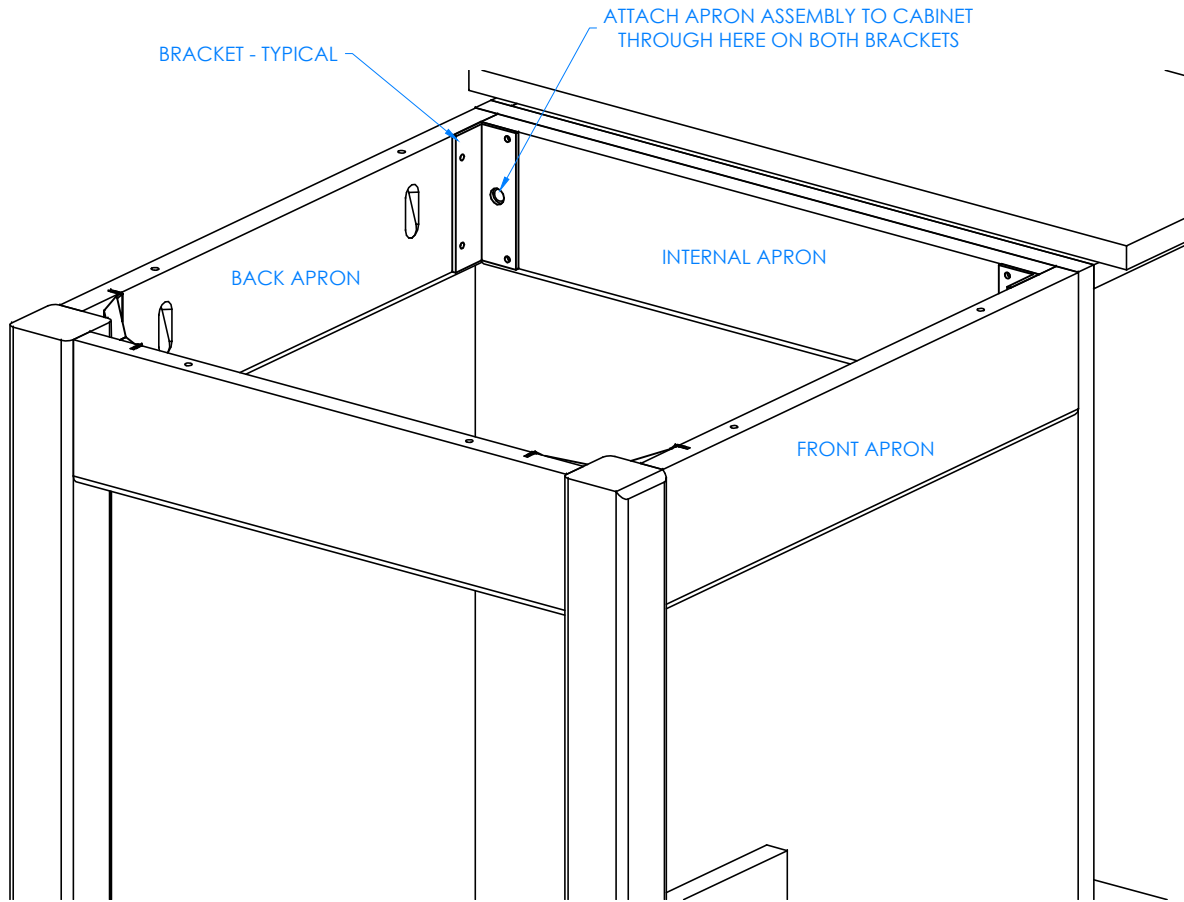

STEP 7:

- POSITION APRON ASSEMBLY SO INNER HOLES OF BRACKETS ON INTERNAL APRON ARE LINED UP WITH TWO HOLES ON LEFT SIDE OF CABINET.
- FRONT APRON WILL BE FLUSH WITH FRONT OF CABINET AND BACK APRON WILL BE FLUSH WITH BACK OF THE CABINET.
- ATTACH APRON ASSEMBLY TO LEFT SIDE OF CABINET WITH HARDWARE PROVIDED.
- ADJUST LEG LEVELERS TO LEVEL APRON ASSEMBLY WITH CABINET.

CLOSE UP OF APRON ASSEMBLY SHOWN
(TOP AND SOFT CLOSE HARDWARE REMOVED
FOR CLARITY)

NOTE:

1.

ALL DIMENSIONS ARE IN INCHES UNLESS NOTED OTHERWISE	DWN BY:	EMR	DATE DWN:	3/23/20
DECIMALS: $\frac{1}{16} = \pm .030$	APR BY:		DATE APR:	
XX = $\pm .020$	APR BY:		DATE APR:	
.XXX = $\pm .010$	APR BY:		DATE APR:	
ANGLES: $\pm 1^{\circ}0$	APR BY:		DATE APR:	
CABINET SQUARENESS: $\pm .0625$	APR BY:		DATE APR:	

CONFIDENTIAL:
ALL DESIGN RIGHTS RESERVED
THE INFORMATION, DATA, DESIGN, AND DRAWINGS EMBODIED IN THIS DOCUMENT AND ALL REPRODUCTIONS THEREOF ARE THE EXCLUSIVE PROPERTY OF DIVERSIFIED WOODCRAFTS, INC.

THESE DOCUMENTS ARE SUPPLIED WITH THE UNDERSTANDING THAT THEY WILL NOT BE DISCLOSED TO THIRD PARTIES WITHOUT WRITTEN CONSENT OF DIVERSIFIED WOODCRAFTS, INC. ANY REPRODUCTION IN PART OR WHOLE WITHOUT WRITTEN CONSENT IS SUBJECT TO LEGAL ACTION.



300 South Krueger Street
Suring, WI 54174
diversifiedwoodcrafts.com

TITLE:
DRAWER BASE DRAWING TABLE - TWO PIECE TOP
ASSEMBLY INSTRUCTIONS

REV.	DESCRIPTION	DATE	NAME	ECN NO.
A	CREATED ASSEMBLY INSTRUCTIONS	3/23/20	EMR	-

REVISION LEVEL

DRAWING NUMBER:	SCALE:	SHEET:	REVISION:
DT-4SA & DT-8A	NTS	9 OF 10	REV A

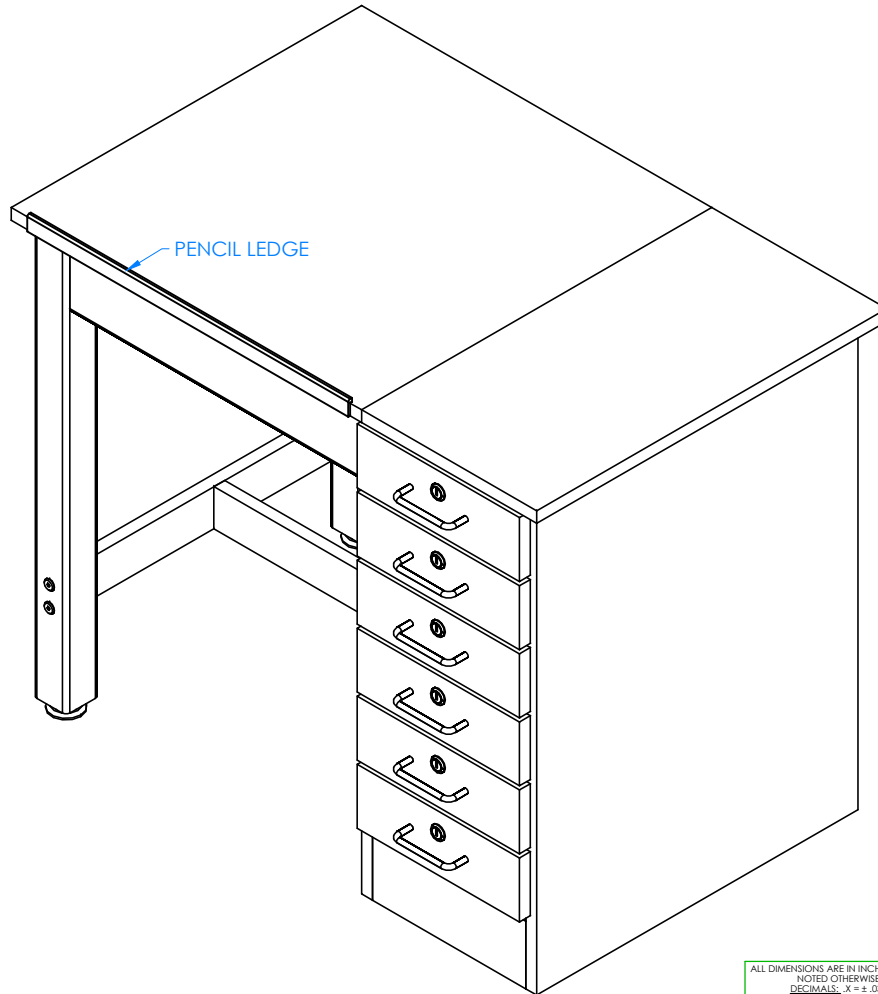

STEP 8:

- LINE UP PENCIL LEDGE ON SIDE OF ADJUSTABLE TOP IN DESIRED LOCATION.
- PRE-DRILL HOLES IN TOP TO PREVENT SPLITTING.
- SCREW PENCIL LEDGE TO TOP USING HARDWARE PROVIDED.
- SET YOUR TABLE IN PLACE.
- PUT DRAWERS BACK IN.

NOTE:

1.

COMPLETE UNIT SHOWN

ALL DIMENSIONS ARE IN INCHES UNLESS NOTED OTHERWISE	DWN BY:	EMR	DATE DWN:	3/23/20
DECIMALS: .X = ± .030 .XX = ± .020 .XXX = ± .010	APR BY:		DATE APR:	
ANGLES: = ± 1° CABINET SQUARENESS = ± .0625	APR BY:		DATE APR:	

CONFIDENTIAL:
ALL DESIGN RIGHTS RESERVED
THE INFORMATION, DATA, DESIGN, AND DRAWINGS EMBODIED IN THIS DOCUMENT AND ALL REPRODUCTIONS THEREOF ARE THE EXCLUSIVE PROPERTY OF DIVERSIFIED WOODCRAFTS, INC.

THESE DOCUMENTS ARE SUPPLIED WITH THE UNDERSTANDING THAT THEY WILL NOT BE DISCLOSED TO THIRD PARTIES WITHOUT WRITTEN CONSENT OF DIVERSIFIED WOODCRAFTS, INC. ANY REPRODUCTION IN PART OR WHOLE WITHOUT WRITTEN CONSENT IS SUBJECT TO LEGAL ACTION.



300 South Krueger Street
Suring, WI 54174
diversifiedwoodcrafts.com

TITLE:
DRAWER BASE DRAWING TABLE - TWO PIECE TOP
ASSEMBLY INSTRUCTIONS

REV.	DESCRIPTION	DATE	NAME	ECN NO.
A	CREATED ASSEMBLY INSTRUCTIONS	3/23/20	EMR	-
REVISION LEVEL				

DRAWING NUMBER:	SCALE:	SHEET:	REVISION:
DT-4SA & DT-8A	NTS	10 OF 10	REV A