

FIRST AID BENCH

FAB-7230 (OAK OR MAPLE)
ASSEMBLY INSTRUCTIONS

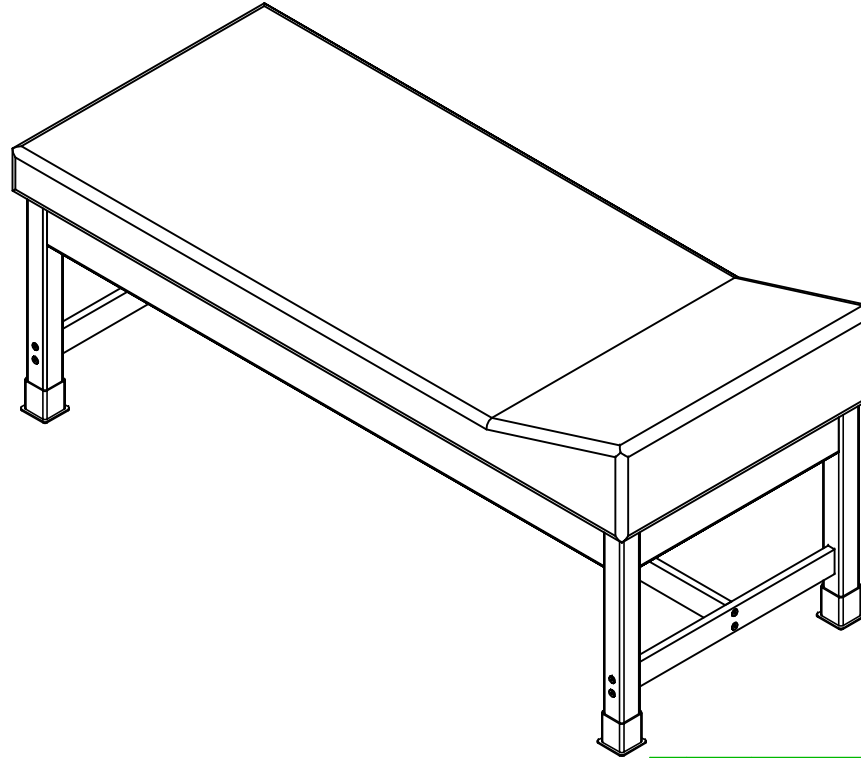

NOTE:

1. MODEL VIEWS MAY NOT REPRESENT EXACT MODEL PURCHASED

DWN BY:	EMK	DWN DATE:	8/20/14
APR BY:		DATE APR:	
APR BY:		DATE APR:	

UNLESS OTHERWISE SPECIFIED
DIMENSION ARE IN INCHES
CABINET SQUARENESS ± .0625
FRACTIONAL VALUES ± 1/32"
- ALL VALUES ± OVERALL -



300 South Krueger Street
Suring, WI 54174
diversifiedwoodcrafts.com

TITLE:
FIRST AID BENCH
ASSEMBLY INSTRUCTIONS

REV.	DESCRIPTION	DATE	NAME	ECN NO.
A	CREATED ASSEMBLY INSTRUCTIONS	8/20/14	EMK	-
REVISION LEVEL				

THIS DRAWING IS THE SOLE PROPERTY OF
DIVERSIFIED WOOD CRAFTS. IT MAY NOT
BE ALTERED OR CHANGED WITHOUT
PERMISSION

DRAWING NUMBER:
FAB-7230

SCALE:	SHEET:	REVISION:
NTS	1 OF 8	REV A

TOOLS REQUIRED

1/2" WRENCH
1/2" SOCKET AND TORQUE WRENCH - OPTIONAL
4MM ALLEN WRENCH

ASSEMBLY COMPONENTS

ITEMS INCLUDED	PART #	PART DESCRIPTION	QTY
APRON AND TOP ASSEMBLY	N/A	APRON ASSEMBLY WITH SUPPORT TOP (FACTORY ASSEMBLY)	1
LEGS	VARIES	LEG, 2.25X2.25X21.25	4
CONFIRMATS - LEGS	227578	SCREW,7MMX90MM,CONN,ALLENHEAD, BLACK	8
CONFIRMATS - STRETCHER	228564	SCREW,7MMX50MM,CONN,ALLENHEAD, BLACK	4
BRACE	N/A	TABLE BRACE - 23.50" LONG	2
STRETCHER	N/A	TABLE STRETCHER - 67.00" LONG	1
LEG HARDWARE KIT	520001-4	LEG HARDWARE KIT, 4 LEGS	1
LEG BOOT	100076	LEG BOOT,BLK RUBBER	4
PAD	250538	9.50X30X72,BLACK,HIGH DENSITY FOAM	1
VELCRO	221594	VELCRO,BLACK,2.00W	2

NOTE:

1.

DWN BY:	EMK	DWN DATE:	8/20/14
APR BY:		DATE APR:	
APR BY:		DATE APR:	

UNLESS OTHERWISE SPECIFIED
DIMENSION ARE IN INCHES
CABINET SQUARENESS ± .0625
FRACTIONAL VALUES ± 1/32"
- ALL VALUES ± OVERALL -



300 South Krueger Street
Suring, WI 54174
diversifiedwoodcrafts.com

TITLE:
FIRST AID BENCH
TOOLS AND ASSEMBLY INSTRUCTIONS

REV.	DESCRIPTION	DATE	NAME	ECH NO.
A	CREATED ASSEMBLY INSTRUCTIONS	8/20/14	EMK	-
				REVISION LEVEL

THIS DRAWING IS THE SOLE PROPERTY OF
DIVERSIFIED WOOD CRAFTS. IT MAY NOT
BE ALTERED OR CHANGED WITHOUT
PERMISSION

DRAWING NUMBER:	SCALE:	SHEET:	REVISION:
FAB-7230	NTS	2 OF 8	REV A

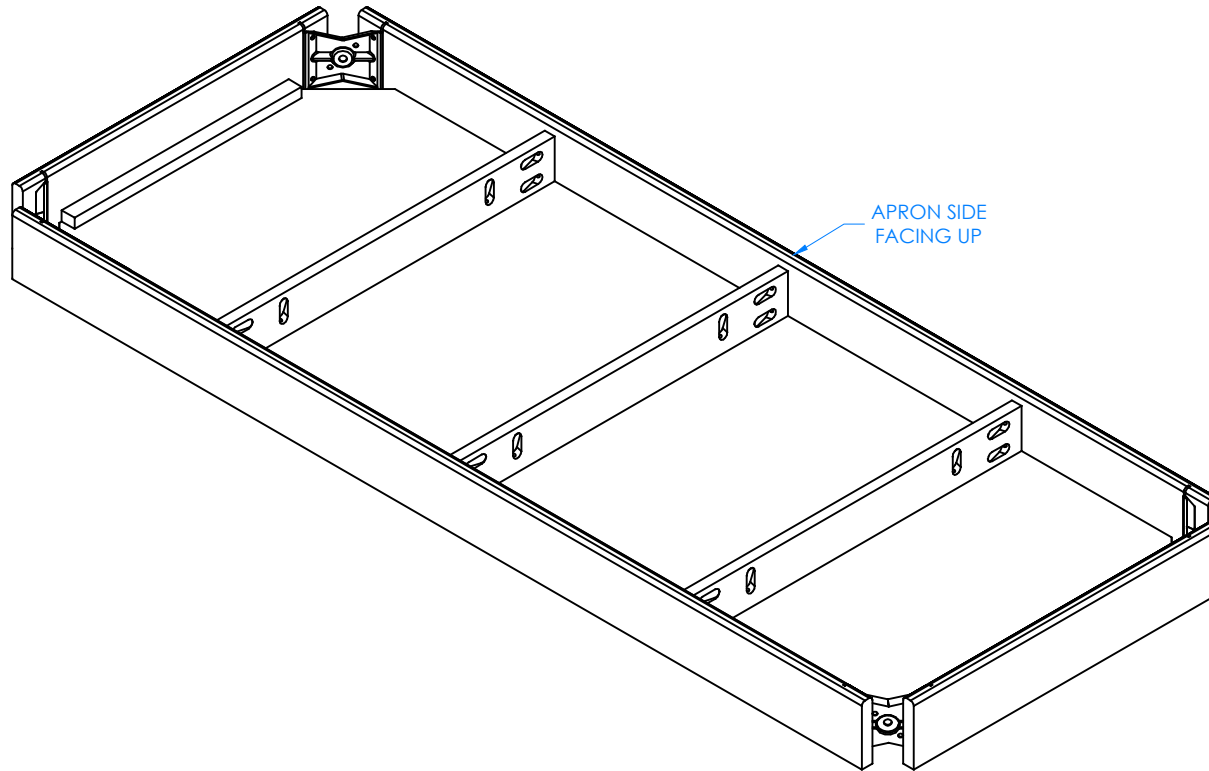

STEP 1:

- LAY TABLE ON FLOOR WITH APRON SIDE FACING UP.

NOTE:

1.

DWN BY:	EMK	DWN DATE:	8/20/14
APR BY:		DATE APR:	
APR BY:		DATE APR:	

UNLESS OTHERWISE SPECIFIED
DIMENSION ARE IN INCHES
CABINET SQUARENESS ± .0625
FRACTIONAL VALUES ± 1/32"
- ALL VALUES ± OVERALL -



300 South Krueger Street
Suring, WI 54174
diversifiedwoodcrafts.com

TITLE:
FIRST AID BENCH
ASSEMBLY INSTRUCTIONS

REV.	DESCRIPTION	DATE	NAME	ECN NO.
A	CREATED ASSEMBLY INSTRUCTIONS	8/20/14	EMK	-
REVISION LEVEL				

THIS DRAWING IS THE SOLE PROPERTY OF
DIVERSIFIED WOOD CRAFTS. IT MAY NOT
BE ALTERED OR CHANGED WITHOUT
PERMISSION

DRAWING NUMBER:

FAB-7230

SCALE:

NTS

SHEET:

3 OF 8

REVISION:

REV A

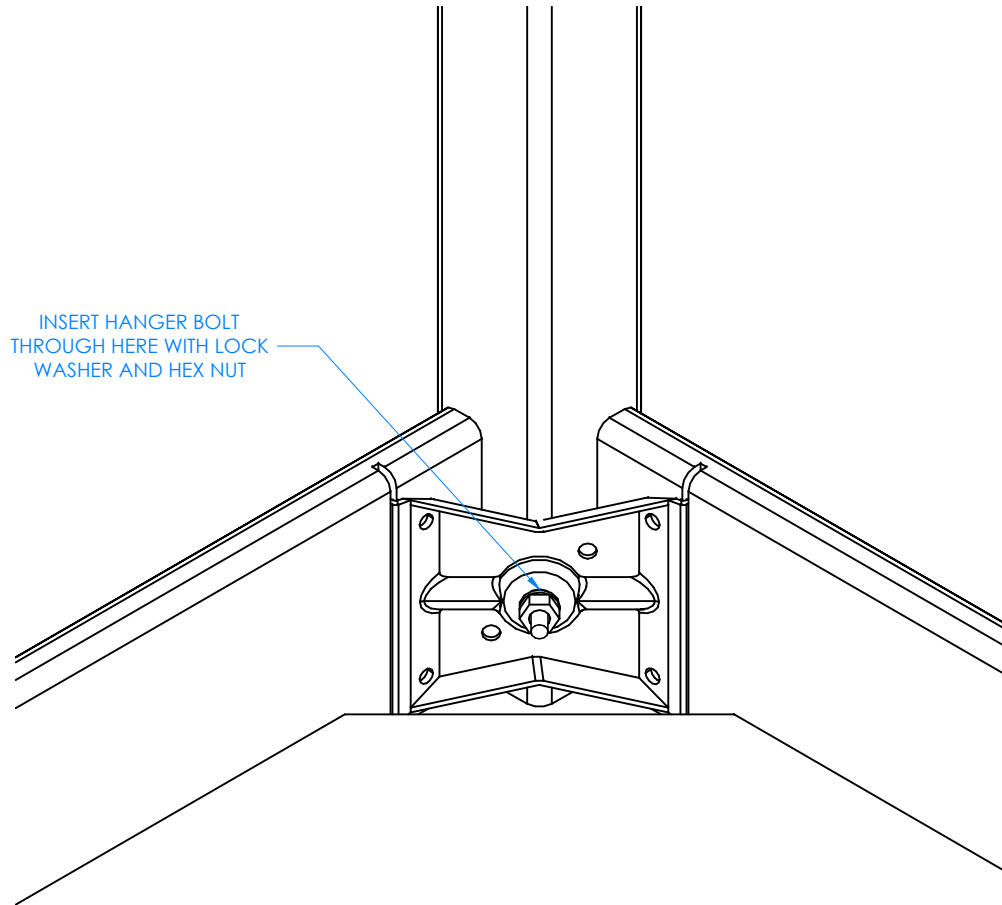

INSERT HANGER BOLT
THROUGH HERE WITH LOCK
WASHER AND HEX NUT

STEP 2:

- INSERT HANGER BOLT ON ONE CORNER LEG THROUGH THE CORNER BRACKET AND INSERT LOCK WASHER AND HEX NUT.
- SCREW ON NUT USING A 1/2" WRENCH OR 1/2" SOCKET AND TORQUE WRENCH.
- DO NOT TIGHTEN ALL THE WAY.
- REPEAT FOR OTHER CORNER LEGS.

CLOSE UP OF CORNER LEG ASSEMBLY

NOTE:

1.

DWN BY:	EMK	DWN DATE:	8/20/14
APR BY:		DATE APR:	
APR BY:		DATE APR:	

UNLESS OTHERWISE SPECIFIED
DIMENSION ARE IN INCHES
CABINET SQUARENESS ± .0625
FRACTIONAL VALUES ± 1/32"
- ALL VALUES ± OVERALL -



300 South Krueger Street
Suring, WI 54174
diversifiedwoodcrafts.com

TITLE:
FIRST AID BENCH
ASSEMBLY INSTRUCTIONS

REV.	DESCRIPTION	DATE	NAME	ECH NO.
A	CREATED ASSEMBLY INSTRUCTIONS	8/20/14	EMK	-
REVISION LEVEL				

THIS DRAWING IS THE SOLE PROPERTY OF
DIVERSIFIED WOOD CRAFTS. IT MAY NOT
BE ALTERED OR CHANGED WITHOUT
PERMISSION

DRAWING NUMBER:

FAB-7230

SCALE:	SHEET:	REVISION:
NTS	4 OF 8	REV A

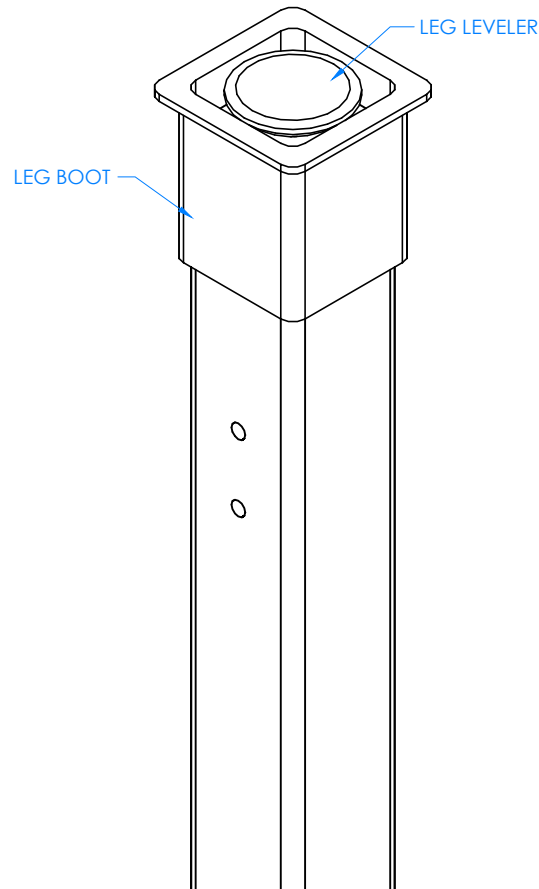

CLOSE UP OF LEG BOOT AND LEVELER ASSEMBLY

STEP 3:

- SLIDE LEG BOOTS ONTO LEGS WITH FLARED END TOWARD BOTTOM OF LEGS.
- SCREW LEG LEVELERS INTO T-NUT ON BOTTOM OF LEG.

NOTE:

- 1.

DWN BY:	EMK	DWN DATE:	8/20/14
APR BY:		DATE APR:	
APR BY:		DATE APR:	

UNLESS OTHERWISE SPECIFIED
DIMENSION ARE IN INCHES
CABINET SQUARENESS ± .0625
FRACTIONAL VALUES ± 1/32"
- ALL VALUES ± OVERALL -



300 South Krueger Street
Suring, WI 54174
diversifiedwoodcrafts.com

TITLE:
FIRST AID BENCH
ASSEMBLY INSTRUCTIONS

REV.	DESCRIPTION	DATE	NAME	ECH NO.
A	CREATED ASSEMBLY INSTRUCTIONS	8/20/14	EMK	-
REVISION LEVEL				

THIS DRAWING IS THE SOLE PROPERTY OF
DIVERSIFIED WOOD CRAFTS. IT MAY NOT
BE ALTERED OR CHANGED WITHOUT
PERMISSION

DRAWING NUMBER:
FAB-7230

SCALE:	SHEET:	REVISION:
NTS	5 OF 8	REV A

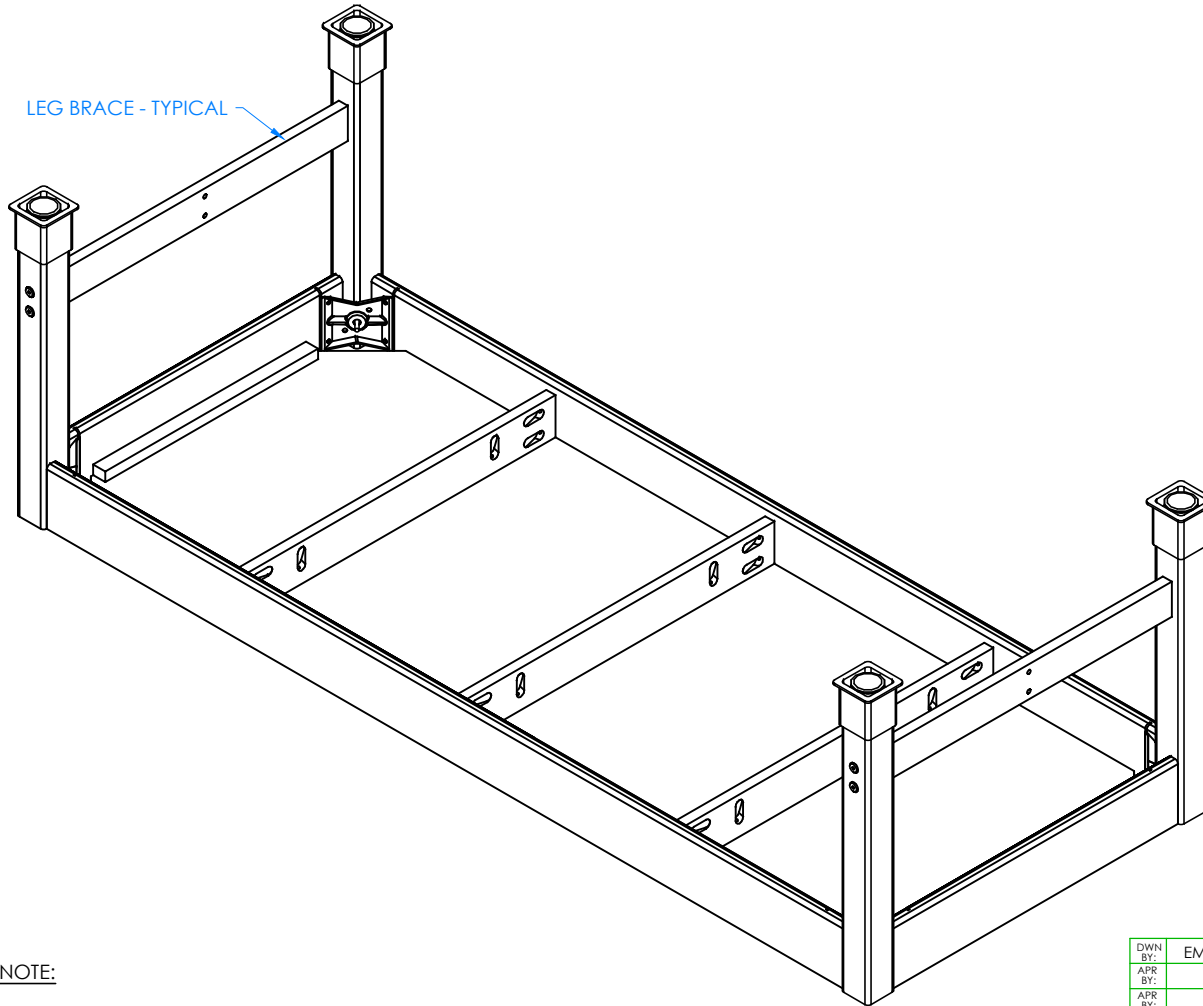

STEP 4:

- ATTACH BRACES TO LEGS.
- INSERT CONFIRMATS INTO ONE LEG AND SCREW INTO BRACE USING A 4MM ALLEN WRENCH.
- REPEAT ON ALL LEGS.
- MAKE SURE BRACES ARE STRAIGHT AND ALL CONFIRMATS ARE SECURE.

NOTE:

1.

DWN BY:	EMK	DWN DATE:	8/20/14
APR BY:		DATE APR:	
APR BY:		DATE APR:	

UNLESS OTHERWISE SPECIFIED
DIMENSION ARE IN INCHES
CABINET SQUARENESS ± .0625
FRACTIONAL VALUES ± 1/32"
- ALL VALUES ± OVERALL -



300 South Krueger Street
Suring, WI 54174
diversifiedwoodcrafts.com

TITLE:
FIRST AID BENCH
ASSEMBLY INSTRUCTIONS

REV.	DESCRIPTION	DATE	NAME	ECH NO.
A	CREATED ASSEMBLY INSTRUCTIONS	8/20/14	EMK	-
REVISION LEVEL				

THIS DRAWING IS THE SOLE PROPERTY OF
DIVERSIFIED WOOD CRAFTS. IT MAY NOT
BE ALTERED OR CHANGED WITHOUT
PERMISSION

DRAWING NUMBER:

FAB-7230

SCALE:

NTS

SHEET:

6 OF 8

REVISION:

REV A

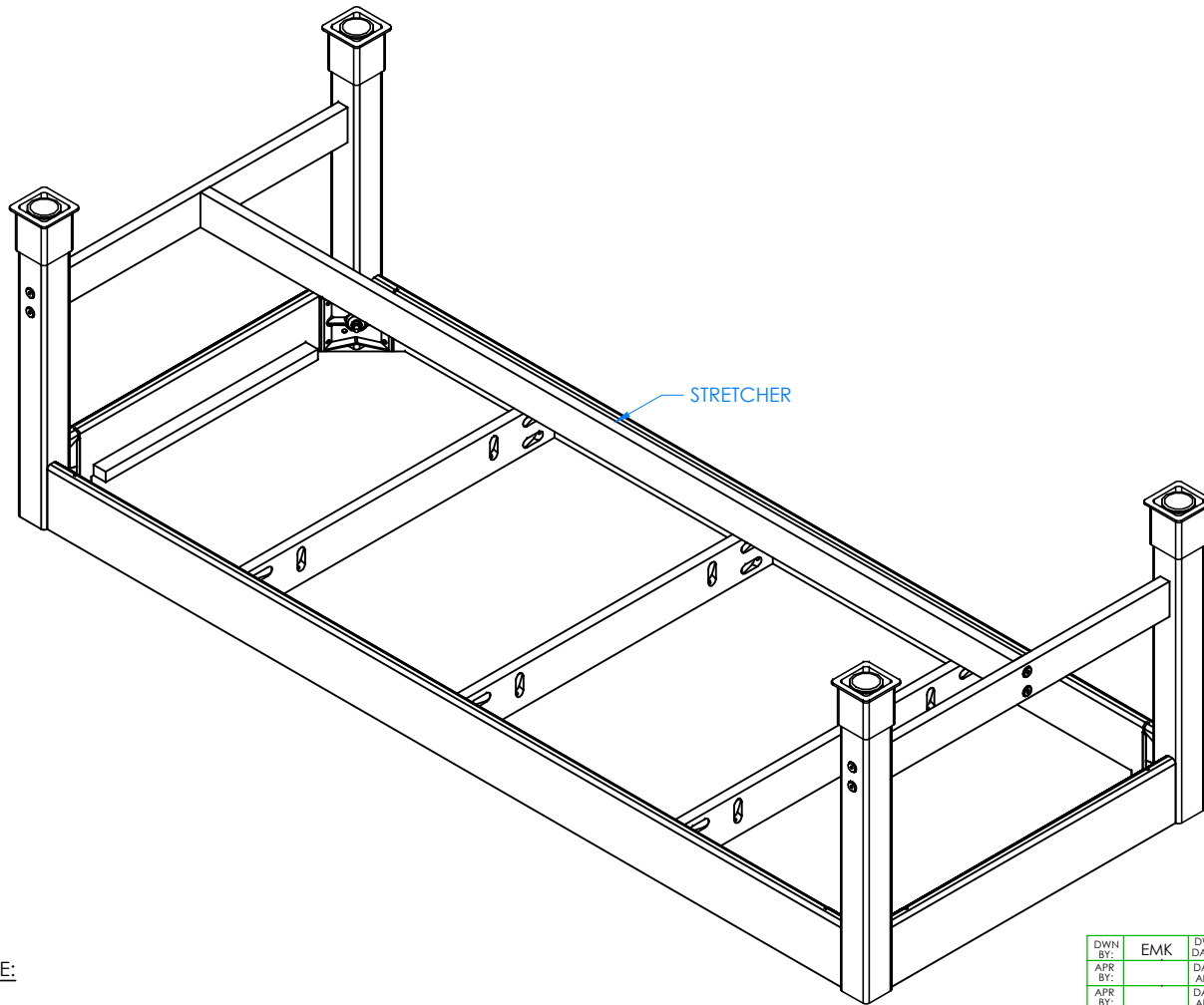

STEP 5:

- INSERT STRETCHER IN BETWEEN BRACES.
- ATTACH STRETCHER TO BRACES WITH HARDWARE PROVIDED.
- GO BACK TO STEP 2 AND TIGHTEN THE HANGER BOLTS FOR EACH LEG USING 1/2" WRENCH OR 1/2" SOCKET AND TORQUE WRENCH. TO A MINIMUM OF 12FT LBS BUT NOT TO EXCEED 17FT LBS.

NOTE:

1.

DWN BY:	EMK	DWN DATE:	8/20/14
APR BY:		DATE APR:	
APR BY:		DATE APR:	

UNLESS OTHERWISE SPECIFIED
DIMENSION ARE IN INCHES
CABINET SQUARENESS ± .0625
FRACTIONAL VALUES ± 1/32"
- ALL VALUES ± OVERALL -



300 South Krueger Street
Suring, WI 54174
diversifiedwoodcrafts.com

TITLE:
FIRST AID BENCH
ASSEMBLY INSTRUCTIONS

REV.	DESCRIPTION	DATE	NAME	ECH NO.
A	CREATED ASSEMBLY INSTRUCTIONS	8/20/14	EMK	-

REVISION LEVEL

THIS DRAWING IS THE SOLE PROPERTY OF
DIVERSIFIED WOOD CRAFTS. IT MAY NOT
BE ALTERED OR CHANGED WITHOUT
PERMISSION

DRAWING NUMBER:

FAB-7230

SCALE:

NTS

SHEET:

7 OF 8

REVISION:

REV A

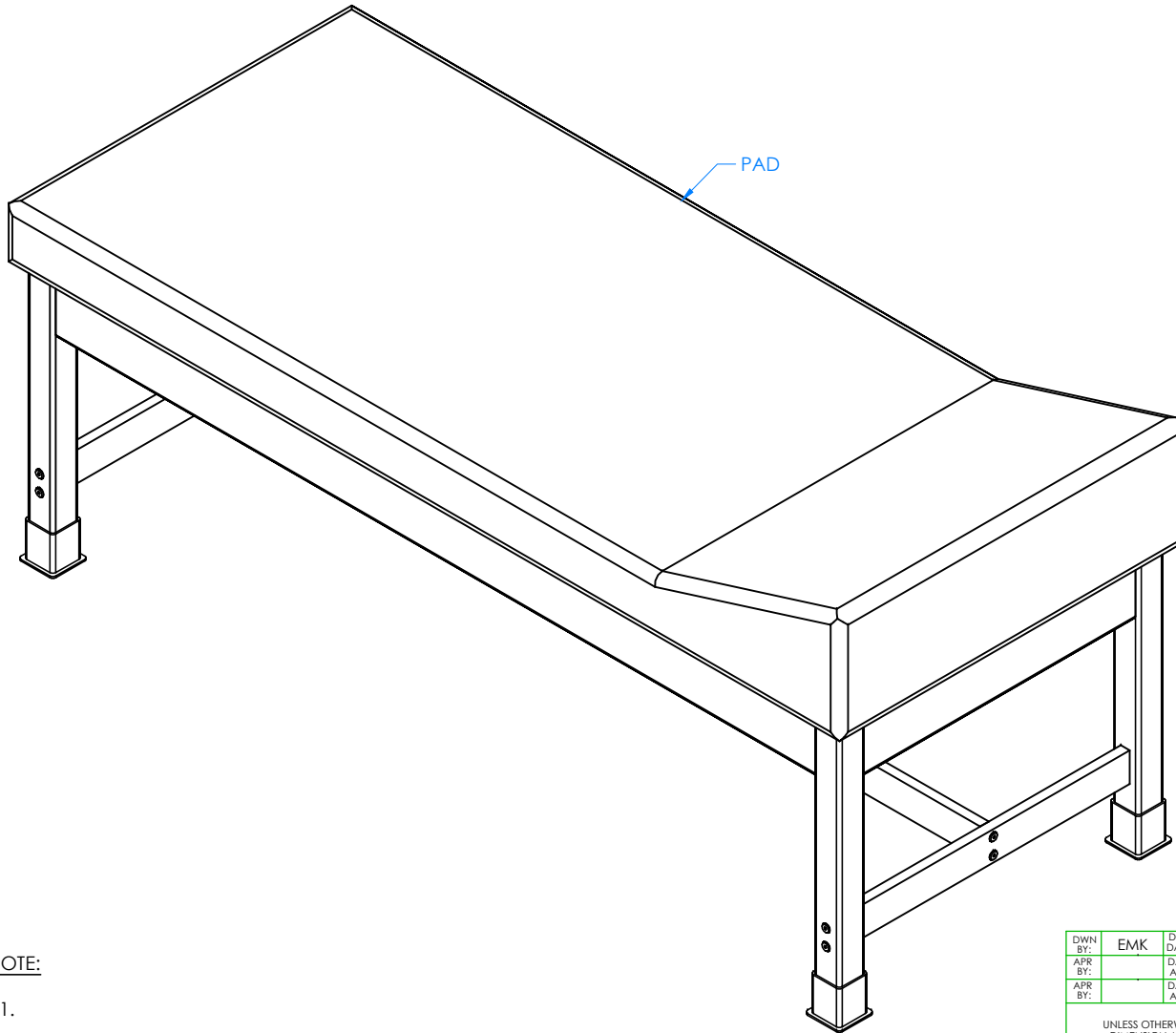

STEP 6:

- TURN TABLE OVER SO TOP IS UP.
- SET YOUR TABLE IN PLACE.
- ADJUST LEG LEVELERS TO LEVEL TABLE.
- SLIDE LEG BOOTS DOWN TO FLOOR.
- ATTACH VELCRO TO SUPPORT PANEL (NOT SHOWN).
- PLACE PAD ON TOP OF PANEL.

NOTE:

1.

COMPLETE UNIT SHOWN

DWN BY:	EMK	DWN DATE:	8/20/14
APR BY:		DATE APR:	
APR BY:		DATE APR:	

UNLESS OTHERWISE SPECIFIED
DIMENSION ARE IN INCHES
CABINET SQUARENESS ± .0625
FRACTIONAL VALUES ± 1/32"
- ALL VALUES ± OVERALL -



300 South Krueger Street
Suring, WI 54174
diversifiedwoodcrafts.com

TITLE:
FIRST AID BENCH
ASSEMBLY INSTRUCTIONS

REV.	DESCRIPTION	DATE	NAME	ECN NO.
A	CREATED ASSEMBLY INSTRUCTIONS	8/20/14	EMK	-

REVISION LEVEL

THIS DRAWING IS THE SOLE PROPERTY OF
DIVERSIFIED WOOD CRAFTS. IT MAY NOT
BE ALTERED OR CHANGED WITHOUT
PERMISSION

DRAWING NUMBER:	SCALE:	SHEET:	REVISION:
FAB-7230	NTS	8 OF 8	REV A