

GLUE AND STAIN BENCH

GSB-6024 & MGSB-6024
ASSEMBLY INSTRUCTIONS

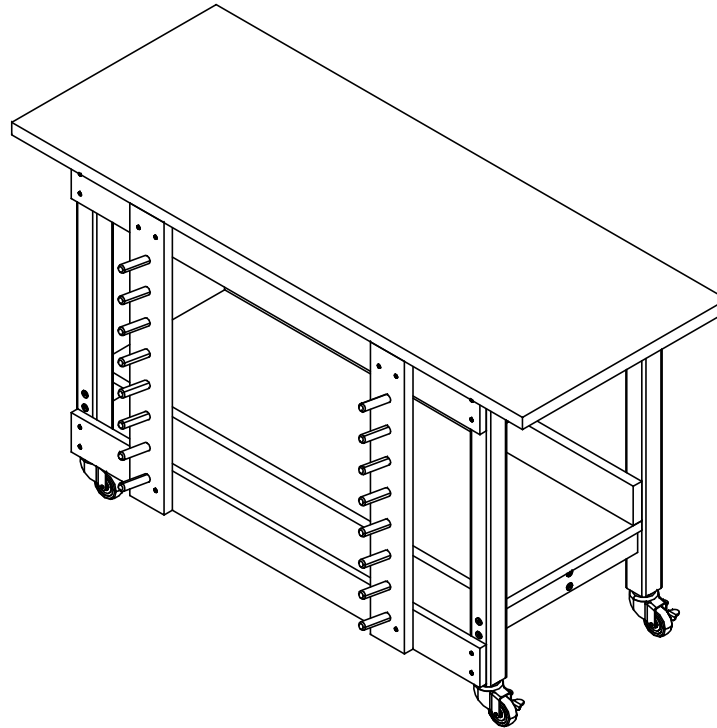

NOTE:

1. MODEL VIEWS MAY NOT REPRESENT EXACT MODEL PURCHASED

DWN BY:	EMK	DWN DATE:	11/11/14
APR BY:		DATE APR:	
APR BY:		DATE APR:	

UNLESS OTHERWISE SPECIFIED
DIMENSION ARE IN INCHES
CABINET SQUARENESS ± .0625
FRACTIONAL VALUES ± 1/32"
- ALL VALUES ± OVERALL -



300 South Krueger Street
Suring, WI 54174
diversifiedwoodcrafts.com

TITLE:
GLUE AND STAIN BENCH
ASSEMBLY INSTRUCTIONS

REV.	DESCRIPTION	DATE	NAME	ECN NO.
A	CREATED ASSEMBLY INSTRUCTIONS	11/11/14	EMK	-
REVISION LEVEL				

THIS DRAWING IS THE SOLE PROPERTY OF
DIVERSIFIED WOOD CRAFTS. IT MAY NOT
BE ALTERED OR CHANGED WITHOUT
PERMISSION

DRAWING NUMBER:

GSB-6024 & MGSB-6024

SCALE:

NTS

SHEET:

1 OF 5

REVISION:

REV A

TOOLS REQUIRED

1/2" WRENCH
1/2" SOCKET AND TORQUE WRENCH - OPTIONAL
4MM ALLEN WRENCH
SCREW DRIVER

ASSEMBLY COMPONENTS

ITEMS INCLUDED	PART #	PART DESCRIPTION	QTY
TOP AND APRON ASSEMBLY	N/A	TOP ASSEMBLY (FACTORY ASSEMBLED)	1
LEGS	501103	LEG,MPL 2.25X2.25X32.25	4
LEG HARDWARE	520001-4	LEG HARDWARE KIT, 4 LEGS	1
LEG BRACE	N/A	LEG BRACE - 16.00" LONG	2
STRETCHER	N/A	STRETCHER - 45.50" LONG	1
SHELF	N/A	SHELF - 1.00"THK X 16.00"W X 48.00"L	1
BACKSPLASH	N/A	BACKSPLASH - 1.00"THK X 4.00"W X 48.00"L	1
CLAMP FRAME - TOP & BOTTOM	N/A	HORIZONTAL PIECE - 0.75"THK X 4.00"W X 48.00"L	2
CLAMP FRAME - SIDES	N/A	VERTICAL PIECE - 1.00"THK X 4.00"W X 29.75"L	2
CONFIRMATS - LEGS	227578	SCREW,7MMX90MM,CONN,ALLENHEAD, BLACK	8
CONFIRMATS - STRETCHERS	228564	SCREW,7MMX50MM,CONN,ALLENHEAD, BLACK	4
SCREWS - SHELF AND BACKSPLASH	100597	SCREW,#8X1.5 QUAD ROUND WASHER	11
SCREWS - FRAME	100066	SCREW,#8X1.5 FSQ SMS TYPE 17	16
LEGS WITH CASTERS	501103	LEG,MPL 2.25X2.25X35	4

NOTE:

1. ****XX**** INDICATES ITEMS ONLY USED FOR THE MGSB-6024.

DWN BY:	EMK	DWN DATE:	11/11/14
APR BY:		DATE APR:	
APR BY:		DATE APR:	

UNLESS OTHERWISE SPECIFIED
DIMENSION ARE IN INCHES
CABINET SQUARENESS ± .0625
FRACTIONAL VALUES ± 1/32"
- ALL VALUES ± OVERALL -



300 South Krueger Street
Suring, WI 54174
diversifiedwoodcrafts.com

TITLE:
GLUE AND STAIN BENCH
TOOLS AND ASSEMBLY COMPONENTS

A	DESCRIPTION	DATE	NAME	ECH NO.
	CREATED ASSEMBLY INSTRUCTIONS	11/11/14	EMK	-
REV.				

REVISION LEVEL

THIS DRAWING IS THE SOLE PROPERTY OF
DIVERSIFIED WOOD CRAFTS. IT MAY NOT
BE ALTERED OR CHANGED WITHOUT
PERMISSION

DRAWING NUMBER:	SCALE:	SHEET:	REVISION:
GSB-6024 & MGSB-6024	NTS	2 OF 5	REV A

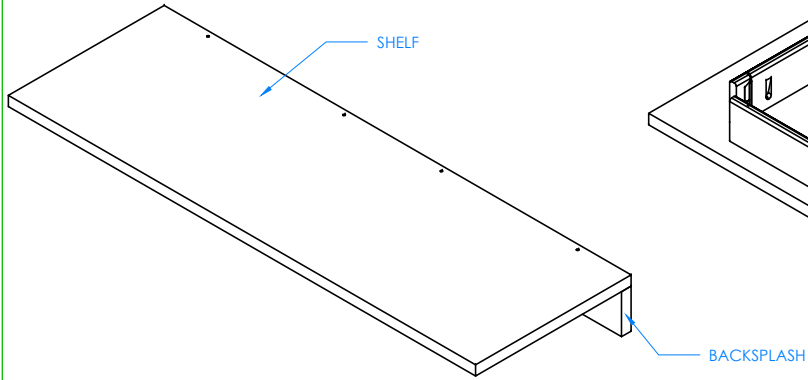

UNDERSIDE OF SHELF SHOWN HERE

STEP 1:

SCREW THE SHELF BACKSPASH ONTO THE SHELF BY GOING THROUGH THE PREDRILLED HOLES ON THE BACKSIDE OF SHELF. ONCE ASSEMBLED, SET ASIDE.

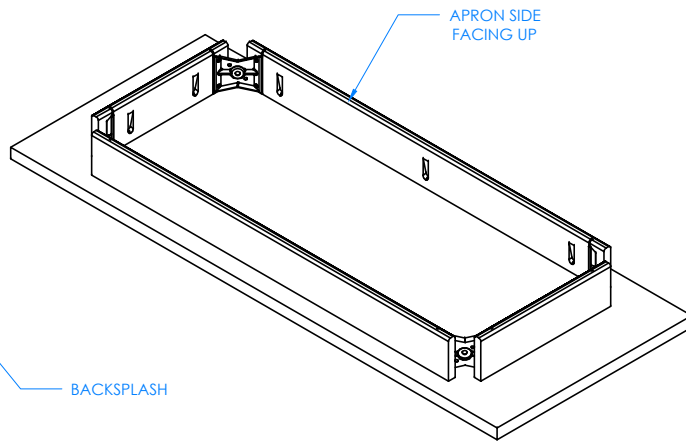

STEP 2:

LAY TOP ASSEMBLY ON FLOOR WITH APRON SIDE FACING UP. BE SURE TO LAY TOP ASSEMBLY ON CLEAN SURFACE TO PREVENT DAMAGE.

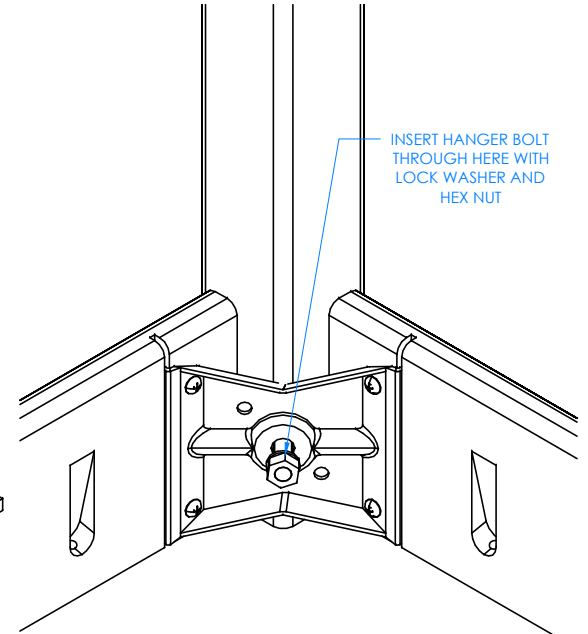

CLOSE UP OF CORNER LEG ASSEMBLY

STEP 3:

INSERT HANGER BOLT ON ONE OF THE LEGS THROUGH THE CORNER BRACKET AND INSERT LOCK WASHER AND HEX NUT. USING 1/2" WRENCH OR 1/2" SOCKET AND TORQUE WRENCH, SCREW ON THE NUT BUT DO NOT TIGHTEN ALL THE WAY. REPEAT FOR THE OTHER LEGS.

NOTE:

- 1.

DWN BY:	EMK	DWN DATE:	11/11/14
APR BY:		DATE APR:	
APR BY:		DATE APR:	

UNLESS OTHERWISE SPECIFIED DIMENSION ARE IN INCHES
 CABINET SQUARENESS ± .0625
 FRACTIONAL VALUES ± 1/32"
 - ALL VALUES ± OVERALL -



300 South Krueger Street
 Suring, WI 54174
 diversifiedwoodcrafts.com

TITLE:
**GLUE AND STAIN BENCH
 ASSEMBLY INSTRUCTIONS**

A	DESCRIPTION	DATE	NAME	ECN NO.
	CREATED ASSEMBLY INSTRUCTIONS	11/11/14	EMK	-
REVISION LEVEL				

THIS DRAWING IS THE SOLE PROPERTY OF DIVERSIFIED WOOD CRAFTS. IT MAY NOT BE ALTERED OR CHANGED WITHOUT PERMISSION

DRAWING NUMBER:	SCALE:	SHEET:	REVISION:
GSB-6024 & MGSB-6024	NTS	3 OF 5	REV A

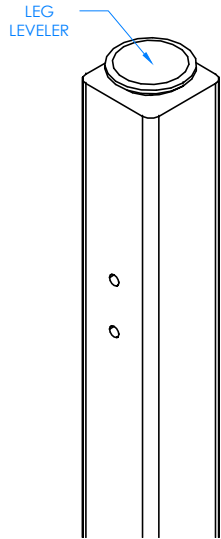

CLOSE UP OF LEG LEVELER ASSEMBLY

STEP 4:

(IF YOUR TABLE HAS CASTERS SKIP TO STEP 5). SCREW LEG LEVELERS INTO T-NUT ON BOTTOM OF LEG.

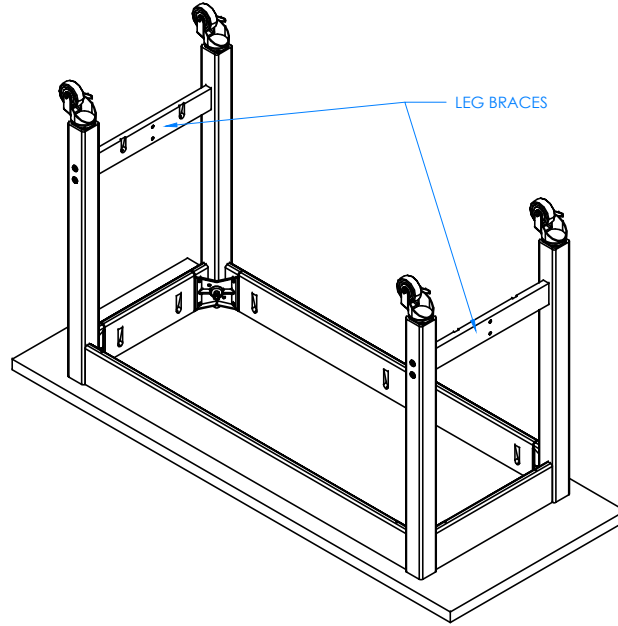

LEG BRACES

STEP 5:

USING A 4MM ALLEN WRENCH, INSERT THE CONFIRMATS INTO ONE LEG AND SCREW INTO THE BRACE, REPEAT FOR THE OTHER 3 LEGS. MAKE SURE BRACES ARE STRAIGHT AND ALL CONFIRMATS ARE TIGHT.

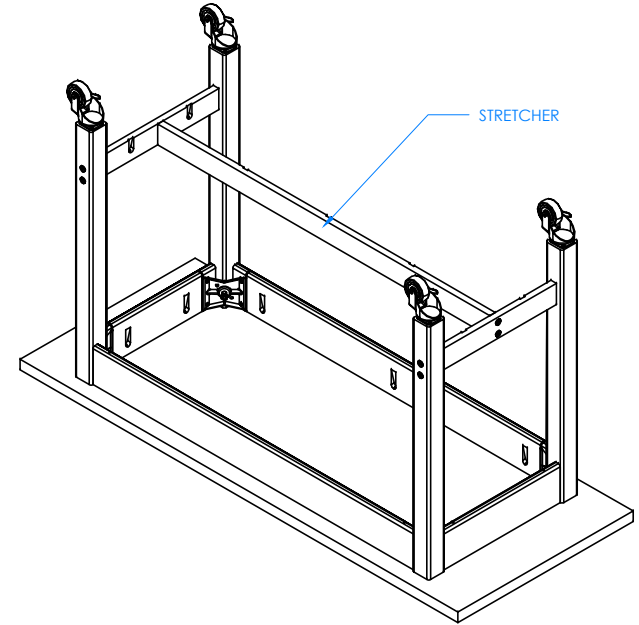

STRETCHER

STEP 6:

INSERT STRETCHER ONCE THE LEG BRACES ARE IN POSITION. ATTACH STRETCHER WITH CONFIRMATS PROVIDED. GO BACK TO STEP 3 AND TIGHTEN UP THE HANGER BOLTS FOR EACH LEG USING A 1/2" WRENCH OR 1/2" SOCKET AND TORQUE WRENCH, TO A MINIMUM OF 12FT LBS BUT NOT TO EXCEED 17FT LBS.

NOTE:

1.

DWN BY:	EMK	DWN DATE:	11/11/14
APR BY:		DATE APR:	
APR BY:		DATE APR:	

UNLESS OTHERWISE SPECIFIED DIMENSION ARE IN INCHES
 CABINET SQUARENESS ± .0625
 FRACTIONAL VALUES ± 1/32"
 - ALL VALUES ± OVERALL -



300 South Krueger Street
 Suring, WI 54174
 diversifiedwoodcrafts.com

TITLE:
GLUE AND STAIN BENCH ASSEMBLY INSTRUCTIONS

REV.	DESCRIPTION	DATE	NAME	ECH NO.
A	CREATED ASSEMBLY INSTRUCTIONS	11/11/14	EMK	-
REVISION LEVEL				

THIS DRAWING IS THE SOLE PROPERTY OF DIVERSIFIED WOOD CRAFTS. IT MAY NOT BE ALTERED OR CHANGED WITHOUT PERMISSION

DRAWING NUMBER:	SCALE:	SHEET:	REVISION:
GSB-6024 & MGSB-6024	NTS	4 OF 5	REV A

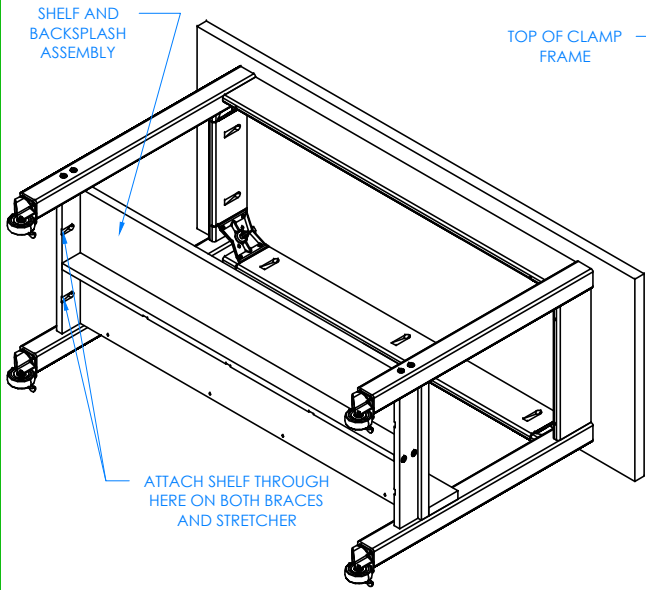

STEP 7:

WITH HELP FROM ANOTHER PERSON, TIP TABLE ON ITS SIDE AND SCREW SHELF AND BACKPLASH ASSEMBLY ONTO THE BRACES AND STRETCHER WITH THE SCREWS PROVIDED.

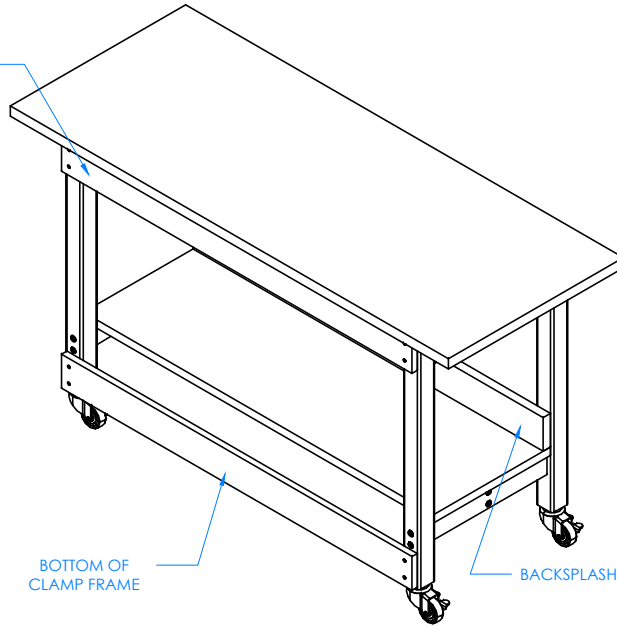

STEP 8:

TIP TABLE UP, SCREW ON TOP AND BOTTOM OF THE CLAMP FRAME TO THE LEGS ON FRONT SIDE OF TABLE (OPPOSITE SIDE OF BACKPLASH) WITH THE SCREWS PROVIDED.

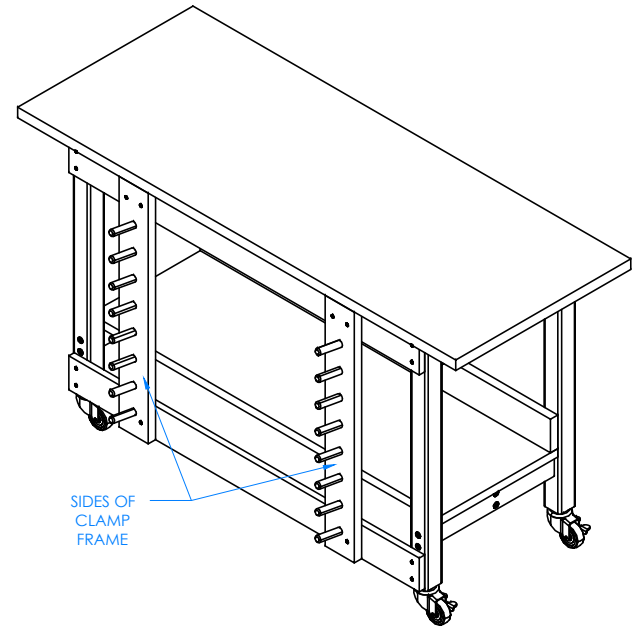

STEP 9:

ATTACH THE SIDES OF THE CLAMP FRAME TO THE TOP AND BOTTOM WITH THE REST OF THE SCREWS. SET TABLE IN PLACE. IF YOUR TABLE HAS LEG LEVELERS, ADJUST LEVELERS TO LEVEL THE TABLE.

NOTE:

- 1.

DWN BY:	EMK	DWN DATE:	11/11/14
APR BY:		DATE APR:	
APR BY:		DATE APR:	

UNLESS OTHERWISE SPECIFIED DIMENSION ARE IN INCHES
 CABINET SQUARENESS ± .0625
 FRACTIONAL VALUES ± 1/32"
 - ALL VALUES ± OVERALL -



300 South Krueger Street
 Suring, WI 54174
 diversifiedwoodcrafts.com

TITLE:
**GLUE AND STAIN BENCH
 ASSEMBLY INSTRUCTIONS**

REV.	DESCRIPTION	DATE	NAME	ECN NO.
A	CREATED ASSEMBLY INSTRUCTIONS	11/11/14	EMK	-
REVISION LEVEL				

THIS DRAWING IS THE SOLE PROPERTY OF
 DIVERSIFIED WOOD CRAFTS. IT MAY NOT
 BE ALTERED OR CHANGED WITHOUT
 PERMISSION

DRAWING NUMBER:	SCALE:	SHEET:	REVISION:
GSB-6024 & MGSB-6024	NTS	5 OF 5	REV A