

LIGHT TABLE

LT-4424
ASSEMBLY INSTRUCTIONS

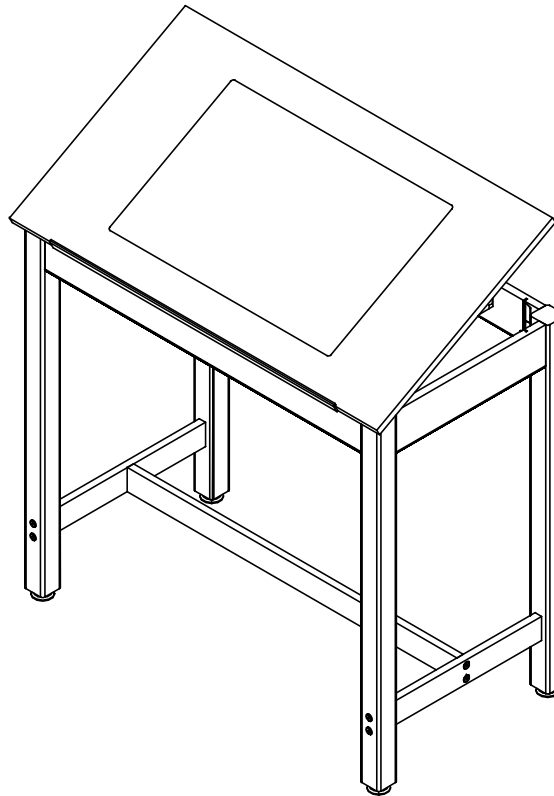

NOTE:

1. MODEL VIEWS MAY NOT REPRESENT EXACT MODEL PURCHASED

ALL DIMENSIONS ARE IN INCHES UNLESS NOTED OTHERWISE	DWN BY:	EMR	DATE DWN:	3/4/14
DECIMALS: X = ± .020	APR BY:		DATE APR:	
XX = ± .020	APR BY:		DATE APR:	
XXX = ± .010	APR BY:		DATE APR:	
ANGLES: = ± 1°	APR BY:		DATE APR:	
CABINET SQUARENESS: = ± .0625	APR BY:		DATE APR:	

CONFIDENTIAL:
ALL DESIGN RIGHTS RESERVED
THE INFORMATION, DATA, DESIGN, AND DRAWINGS EMBODIED IN THIS DOCUMENT AND ALL REPRODUCTIONS THEREOF ARE THE EXCLUSIVE PROPERTY OF DIVERSIFIED WOODCRAFTS, INC.

THESE DOCUMENTS ARE SUPPLIED WITH THE UNDERSTANDING THAT THEY WILL NOT BE DISCLOSED TO THIRD PARTIES WITHOUT WRITTEN CONSENT OF DIVERSIFIED WOODCRAFTS, INC. ANY REPRODUCTION IN PART OR WHOLE WITHOUT WRITTEN CONSENT IS SUBJECT TO LEGAL ACTION.



300 South Krueger Street
Suring, WI 54174
diversifiedwoodcrafts.com

TITLE:
LIGHT TABLE
ASSEMBLY INSTRUCTIONS

REV.	DESCRIPTION	DATE	NAME	ECN NO.
A	CREATED ASSEMBLY INSTRUCTIONS	3/4/14	EMR	-
REVISION LEVEL				

DRAWING NUMBER:	SCALE:	SHEET:	REVISION:
LT-4424	NTS	1 OF 10	REV A

TOOLS REQUIRED

1/2" WRENCH
1/2" SOCKET & TORQUE WRENCH - OPTIONAL
4MM ALLEN WRENCH

ASSEMBLY COMPONENTS

ITEMS INCLUDED	PART #	PART DESCRIPTION	QTY
TOP, APRONS, LIGHT BOX ASSEMBLY	N/A	TOP ASSEMBLED (FACTORY ASSEMBLED)	1
LEGS	L39.75-LBMP	LEG, TABLE, MPL 39.75, W/LEG BRACE	4
LEG HARDWARE	520001-4	LEG HARDWARE KIT, 4 LEGS	1
LEG BRACE	N/A	LEG BRACE - 18" LONG	2
STRETCHER	N/A	LEG STRETCHER - 39.50" LONG	1
PENCIL LEDGE	14-0027	PENCIL LEDGE - 34"	1
SCREWS - PENCIL LEDGE	236263	SCREW, #6X3/4 TRUSS HEAD, QUAD, BLACK	4
CONFIRMATS - LEGS	227578	SCREW, 7MMX90MM, CONN, ALLENHEAD, BLACK	8
CONFIRMATS - STRETCHER	228564	SCREW, 7MMX50MM, CONN, ALLENHEAD, BLACK	4

NOTE:

1.

ALL DIMENSIONS ARE IN INCHES UNLESS NOTED OTHERWISE		DWN BY:	EMR	DATE DWN:	3/4/14
DECIMALS: .X = ± .030 .XX = ± .020 .XXX = ± .010		APR BY:		DATE APR:	
ANGLES: = ± 1°		APR BY:		DATE APR:	
CABINET SQUARENESS: = ± .0625		APR BY:		DATE APR:	
<p>CONFIDENTIAL: ALL DESIGN RIGHTS RESERVED THE INFORMATION, DATA, DESIGN, AND DRAWINGS EMBODIED IN THIS DOCUMENT AND ALL REPRODUCTIONS THEREOF ARE THE EXCLUSIVE PROPERTY OF DIVERSIFIED WOODCRAFTS, INC.</p> <p>THESE DOCUMENTS ARE SUPPLIED WITH THE UNDERSTANDING THAT THEY WILL NOT BE DISCLOSED TO THIRD PARTIES WITHOUT WRITTEN CONSENT OF DIVERSIFIED WOODCRAFTS, INC. ANY REPRODUCTION IN PART OR WHOLE WITHOUT WRITTEN CONSENT IS SUBJECT TO LEGAL ACTION.</p>					



300 South Krueger Street
Suring, WI 54174
diversifiedwoodcrafts.com

TITLE:
LIGHT TABLE
TOOLS AND ASSEMBLY COMPONENTS

DRAWING NUMBER: **LT-4424**

SCALE: NTS SHEET: 2 OF 10 REVISION: REV A

A	CREATED ASSEMBLY INSTRUCTIONS	3/4/14	EMR	-
REV.	DESCRIPTION	DATE	NAME	ECN NO.
REVISION LEVEL				

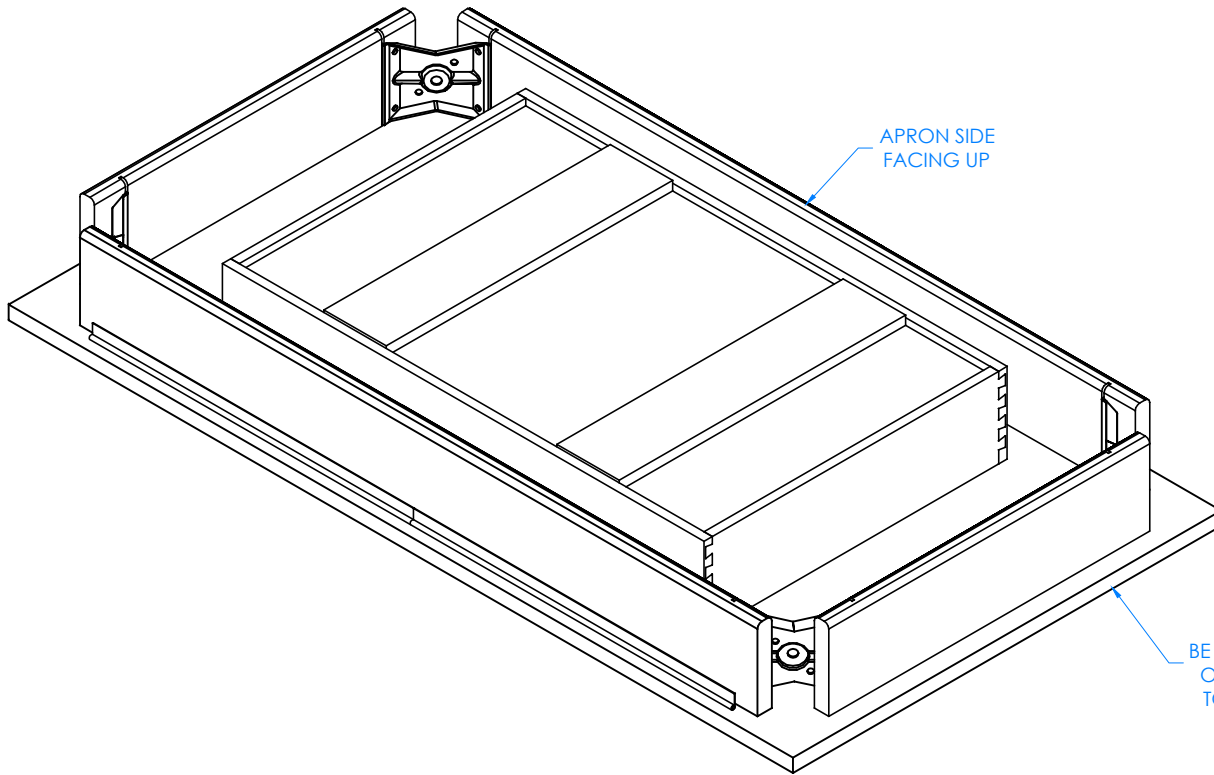

STEP 1:

- LAY TOP ASSEMBLY ON FLOOR WITH APRON SIDE FACING UP.

****NOTE****
BE SURE TOP ASSEMBLY IS ON A CLEAN SURFACE TO PREVENT DAMAGE

NOTE:

1.

ALL DIMENSIONS ARE IN INCHES UNLESS NOTED OTHERWISE	DWN BY:	EMR	DATE DWN:	3/4/14
DECIMALS: $\frac{1}{16}$ = ± .030	APR BY:		DATE APR:	
XX = ± .020	APR BY:		DATE APR:	
.XXX = ± .010	APR BY:		DATE APR:	
ANGLES: = ± 1°	APR BY:		DATE APR:	
CABINET SQUARENESS: = ± .0625	APR BY:		DATE APR:	

CONFIDENTIAL:
ALL DESIGN RIGHTS RESERVED
THE INFORMATION, DATA, DESIGN, AND DRAWINGS EMBODIED IN THIS DOCUMENT AND ALL REPRODUCTIONS THEREOF ARE THE EXCLUSIVE PROPERTY OF DIVERSIFIED WOODCRAFTS, INC.

THESE DOCUMENTS ARE SUPPLIED WITH THE UNDERSTANDING THAT THEY WILL NOT BE DISCLOSED TO THIRD PARTIES WITHOUT WRITTEN CONSENT OF DIVERSIFIED WOODCRAFTS, INC. ANY REPRODUCTION IN PART OR WHOLE WITHOUT WRITTEN CONSENT IS SUBJECT TO LEGAL ACTION.



300 South Krueger Street
Suring, WI 54174
diversifiedwoodcrafts.com

TITLE:
LIGHT TABLE ASSEMBLY INSTRUCTIONS

REV.	DESCRIPTION	DATE	NAME	ECN NO.
A	CREATED ASSEMBLY INSTRUCTIONS	3/4/14	EMR	-
REVISION LEVEL				

DRAWING NUMBER:	SCALE:	SHEET:	REVISION:
LT-4424	NTS	3 OF 10	REV A

STEP 2:

- INSERT HANGER BOLT ON ONE LEG THROUGH THE CORNER BRACKET AND INSERT THE LOCK WASHER AND HEX NUT.
- SCREW ON NUT USING A 1/2" WRENCH OR 1/2" SOCKET AND TORQUE WRENCH.
- DO NOT TIGHTEN ALL THE WAY.
- REPEAT FOR THE OTHER LEGS.
- THE LEGS WITH A CHAMFER MUST GO ON THE FRONT OF THE TABLE WITH CHAMFERED EDGE FACING OUT.

INSERT HANGER BOLT THROUGH HERE WITH LOCK WASHER AND HEX NUT

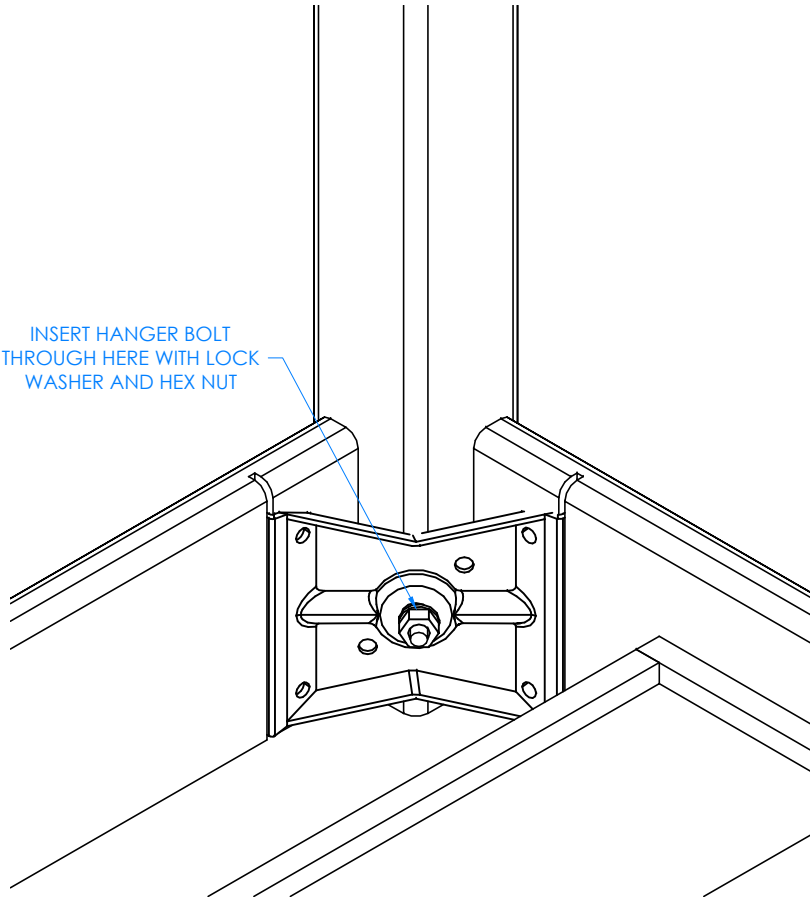

CLOSE UP OF CORNER LEG ASSEMBLY

FRONT LEG

BACK LEG

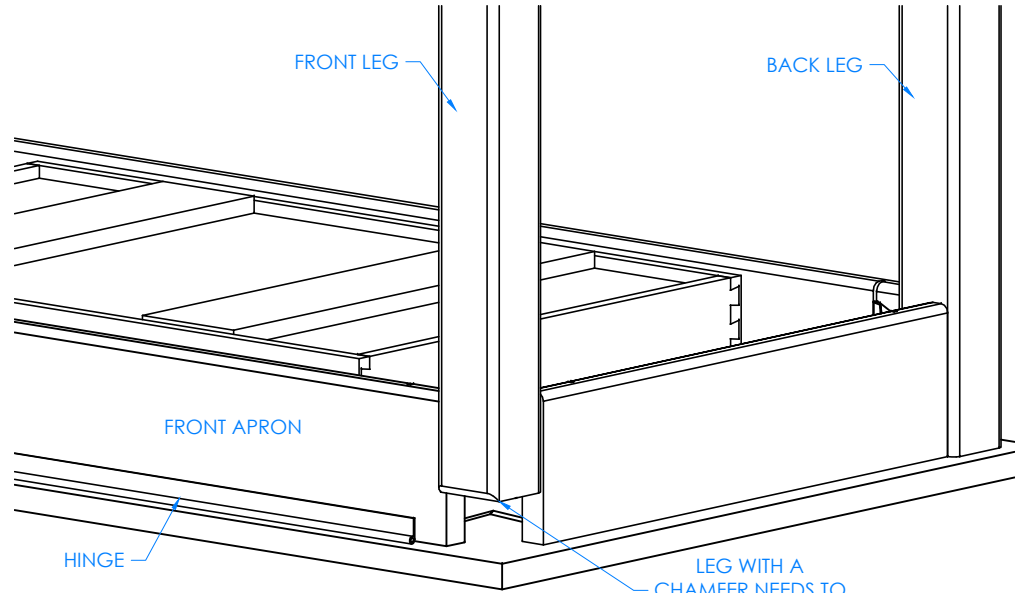

FRONT APRON

HINGE

LEG WITH A CHAMFER NEEDS TO BE FACING OUT

CLOSE UP OF LEG WITH A CHAMFER

NOTE:

1.

ALL DIMENSIONS ARE IN INCHES UNLESS NOTED OTHERWISE	DWN BY:	EMR	DATE DWN:	3/4/14
DECIMALS: .X = ± .030	APR BY:		DATE APR:	
.XX = ± .020	APR BY:		DATE APR:	
.XXX = ± .010	APR BY:		DATE APR:	
ANGLES: = ± 1°0	APR BY:		DATE APR:	
CABINET SQUARENESS = ± .0625	APR BY:		DATE APR:	

CONFIDENTIAL:
ALL DESIGN RIGHTS RESERVED
THE INFORMATION, DATA, DESIGN, AND DRAWINGS EMBODIED IN THIS DOCUMENT AND ALL REPRODUCTIONS THEREOF ARE THE EXCLUSIVE PROPERTY OF DIVERSIFIED WOODCRAFTS, INC.

THESE DOCUMENTS ARE SUPPLIED WITH THE UNDERSTANDING THAT THEY WILL NOT BE DISCLOSED TO THIRD PARTIES WITHOUT WRITTEN CONSENT OF DIVERSIFIED WOODCRAFTS, INC. ANY REPRODUCTION IN PART OR WHOLE WITHOUT WRITTEN CONSENT IS SUBJECT TO LEGAL ACTION.



300 South Krueger Street
Suring, WI 54174
diversifiedwoodcrafts.com

TITLE:
LIGHT TABLE
ASSEMBLY INSTRUCTIONS

REV.	DESCRIPTION	DATE	NAME	ECN NO.
A	CREATED ASSEMBLY INSTRUCTIONS	3/4/14	EMR	-

REVISION LEVEL

DRAWING NUMBER:

LT-4424

SCALE:

NTS

SHEET:

4 OF 10

REVISION:

REV A

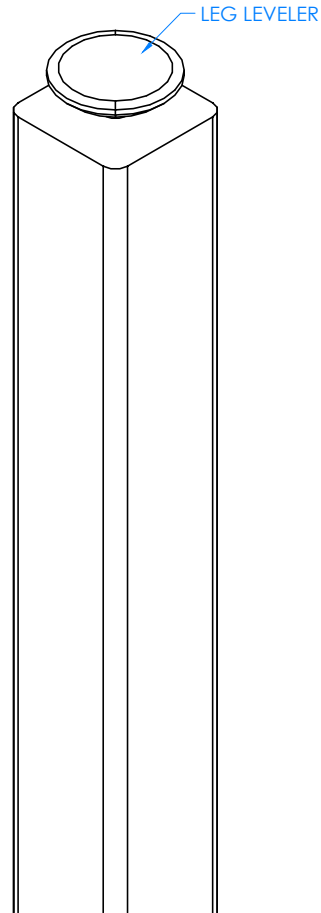

CLOSE UP OF LEG LEVELER ASSEMBLY

STEP 3:

- SCREW LEG LEVELERS INTO T-NUT ON BOTTOM OF LEGS.

NOTE:

1.

ALL DIMENSIONS ARE IN INCHES UNLESS NOTED OTHERWISE	DWN BY:	EMR	DATE DWN:	3/4/14
DECIMALS: $X = \pm .020$	APR BY:		DATE APR:	
$XX = \pm .020$	APR BY:		DATE APR:	
$XXX = \pm .010$	APR BY:		DATE APR:	
ANGLES: $= \pm 1^{\circ}$	APR BY:		DATE APR:	
CABINET SQUARENESS: $= \pm .0625$	APR BY:		DATE APR:	

CONFIDENTIAL:
ALL DESIGN RIGHTS RESERVED
THE INFORMATION, DATA, DESIGN, AND DRAWINGS EMBODIED IN THIS DOCUMENT AND ALL REPRODUCTIONS THEREOF ARE THE EXCLUSIVE PROPERTY OF DIVERSIFIED WOODCRAFTS, INC.

THESE DOCUMENTS ARE SUPPLIED WITH THE UNDERSTANDING THAT THEY WILL NOT BE DISCLOSED TO THIRD PARTIES WITHOUT WRITTEN CONSENT OF DIVERSIFIED WOODCRAFTS, INC. ANY REPRODUCTION IN PART OR WHOLE WITHOUT WRITTEN CONSENT IS SUBJECT TO LEGAL ACTION.



300 South Krueger Street
Suring, WI 54174
diversifiedwoodcrafts.com

TITLE:
LIGHT TABLE
ASSEMBLY INSTRUCTIONS

REV.	DESCRIPTION	DATE	NAME	ECN NO.
A	CREATED ASSEMBLY INSTRUCTIONS	3/4/14	EMR	-

REVISION LEVEL

DRAWING NUMBER:	SCALE:	SHEET:	REVISION:
LT-4424	NTS	5 OF 10	REV A

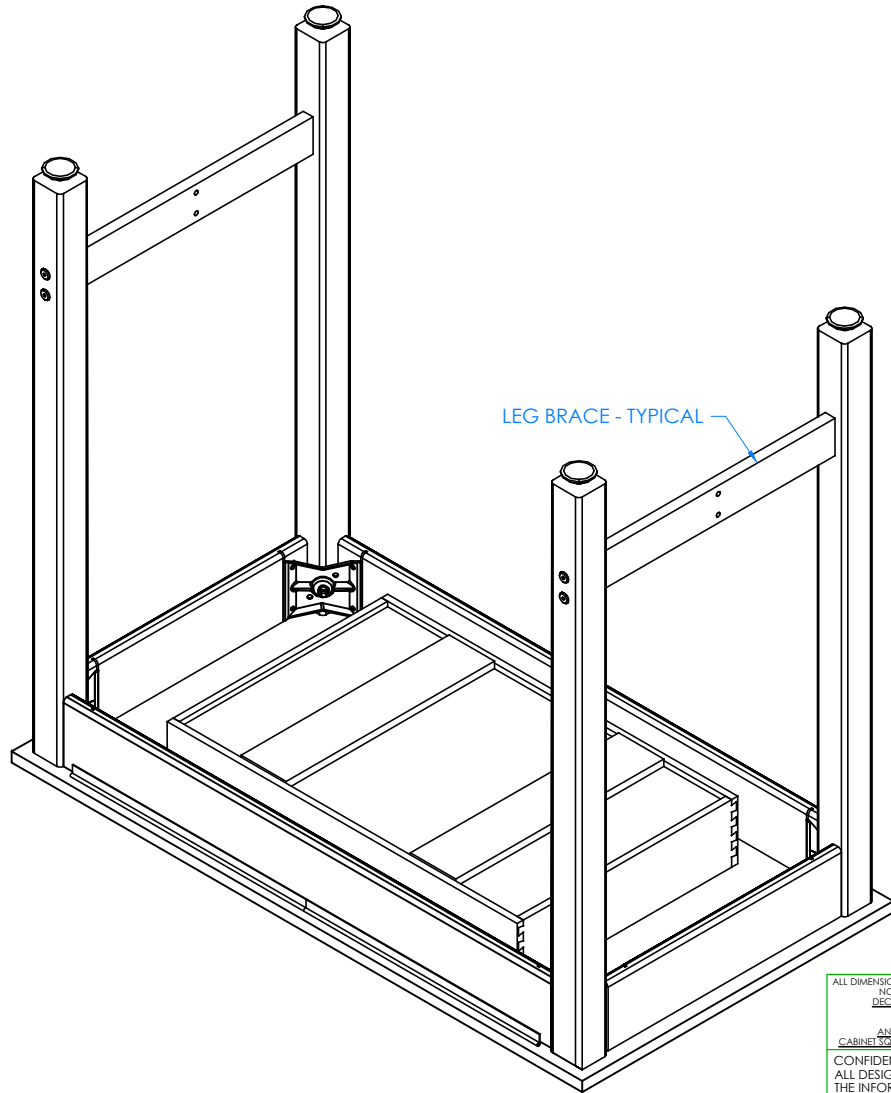

STEP 4:

- ATTACH BRACES TO LEGS.
- INSERT CONFIRMATS INTO ONE LEG AND SCREW INTO BRACE.
- REPEAT ON OTHER LEGS.
- MAKE SURE BRACES ARE STRAIGHT AND ALL CONFIRMATS ARE TIGHT.

NOTE:

1.

ALL DIMENSIONS ARE IN INCHES UNLESS NOTED OTHERWISE	DWN BY:	EMR	DATE DWN:	3/4/14
DECIMALS: X = ± .030 XX = ± .020 XXX = ± .010	APR BY:		DATE APR:	
ANGLES: = ± 1° CABINET SQUARENESS: = ± .0625	APR BY:		DATE APR:	

CONFIDENTIAL:
ALL DESIGN RIGHTS RESERVED
THE INFORMATION, DATA, DESIGN, AND DRAWINGS EMBODIED IN THIS DOCUMENT AND ALL REPRODUCTIONS THEREOF ARE THE EXCLUSIVE PROPERTY OF DIVERSIFIED WOODCRAFTS, INC.

THESE DOCUMENTS ARE SUPPLIED WITH THE UNDERSTANDING THAT THEY WILL NOT BE DISCLOSED TO THIRD PARTIES WITHOUT WRITTEN CONSENT OF DIVERSIFIED WOODCRAFTS, INC. ANY REPRODUCTION IN PART OR WHOLE WITHOUT WRITTEN CONSENT IS SUBJECT TO LEGAL ACTION.



300 South Krueger Street
Suring, WI 54174
diversifiedwoodcrafts.com

TITLE:
LIGHT TABLE
ASSEMBLY INSTRUCTIONS

REV.	DESCRIPTION	DATE	NAME	ECN NO.
A	CREATED ASSEMBLY INSTRUCTIONS	3/4/14	EMR	-

REVISION LEVEL

DRAWING NUMBER:	SCALE:	SHEET:	REVISION:
LT-4424	NTS	6 OF 10	REV A

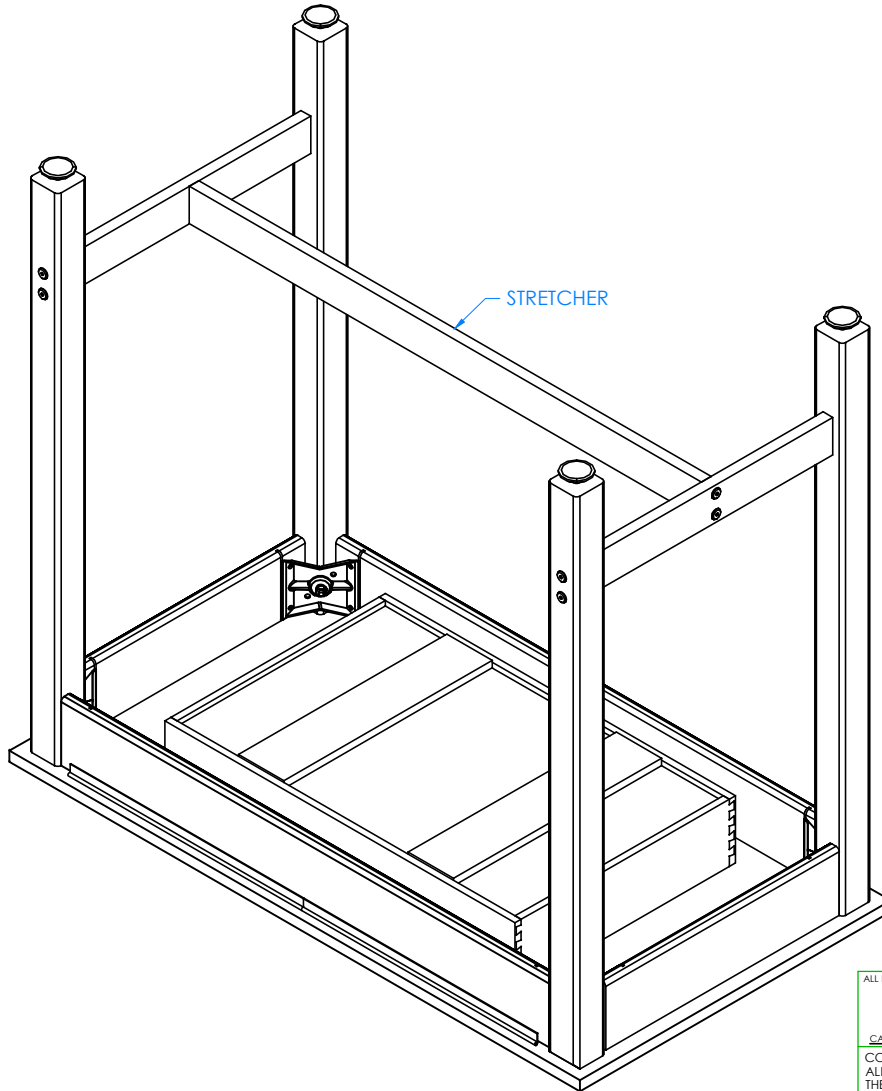

STEP 5:

- INSERT STRETCHER IN BETWEEN BRACES.
- ATTACH STRETCHER WITH HARDWARE PROVIDED.
- GO BACK TO STEP 2 AND TIGHTEN UP THE HANGER BOLTS FOR EACH LEG USING A 1/2" WRENCH OR 1/2" SOCKET AND TORQUE WRENCH, TO A MINIMUM OF 12FT LBS BUT NOT TO EXCEED 17FT LBS.

NOTE:

1.

ALL DIMENSIONS ARE IN INCHES UNLESS NOTED OTHERWISE	DWN BY:	EMR	DATE DWN:	3/4/14
DECIMALS: .X = ± .030 .XX = ± .020 .XXX = ± .010	APR BY:		DATE APR:	
ANGLES: = ± 1° CABINET SQUARENESS = ± .0625	APR BY:		DATE APR:	

CONFIDENTIAL:
ALL DESIGN RIGHTS RESERVED
THE INFORMATION, DATA, DESIGN, AND DRAWINGS EMBODIED IN THIS DOCUMENT AND ALL REPRODUCTIONS THEREOF ARE THE EXCLUSIVE PROPERTY OF DIVERSIFIED WOODCRAFTS, INC.

THESE DOCUMENTS ARE SUPPLIED WITH THE UNDERSTANDING THAT THEY WILL NOT BE DISCLOSED TO THIRD PARTIES WITHOUT WRITTEN CONSENT OF DIVERSIFIED WOODCRAFTS, INC. ANY REPRODUCTION IN PART OR WHOLE WITHOUT WRITTEN CONSENT IS SUBJECT TO LEGAL ACTION.



300 South Krueger Street
Suring, WI 54174
diversifiedwoodcrafts.com

TITLE:
LIGHT TABLE
ASSEMBLY INSTRUCTIONS

REV.	DESCRIPTION	DATE	NAME	ECN NO.
A	CREATED ASSEMBLY INSTRUCTIONS	3/4/14	EMR	-

REVISION LEVEL

DRAWING NUMBER:	SCALE:	SHEET:	REVISION:
LT-4424	NTS	7 OF 10	REV A

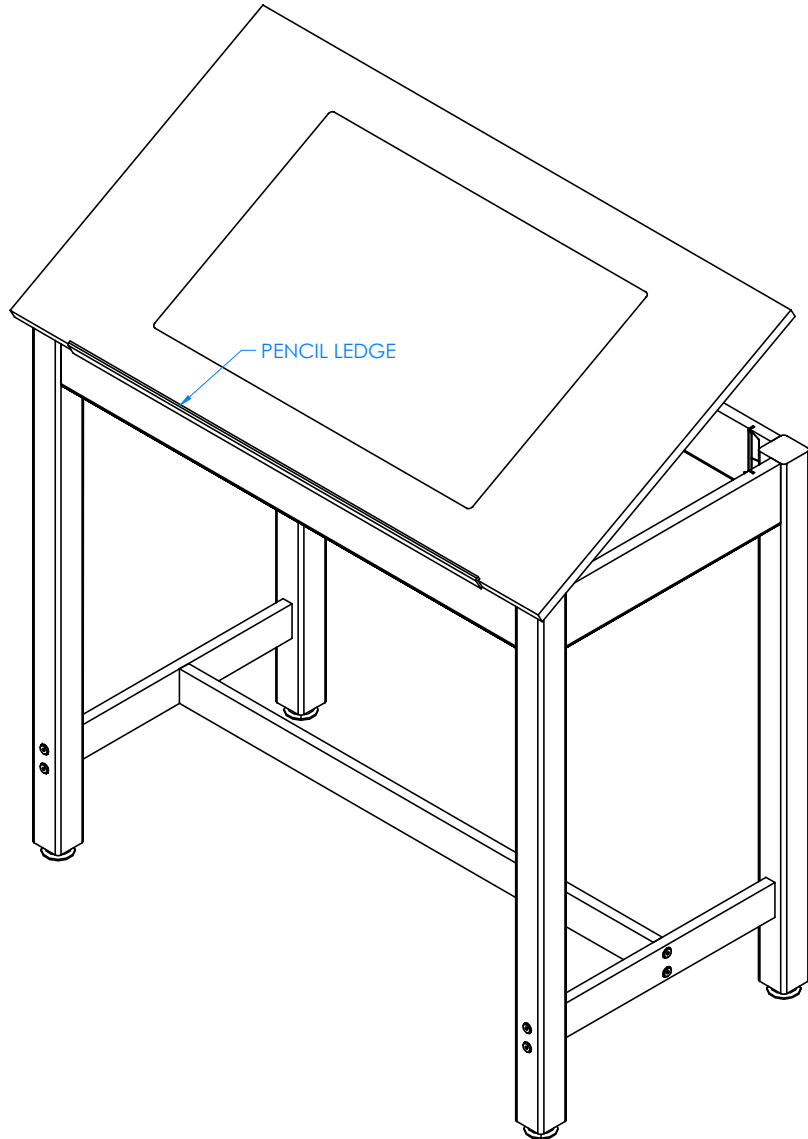

STEP 6:

- TURN TABLE OVER SOTOP IS UP.
- SET TABLE IN PLACE.
- LINE PENCIL LEDGE ON SIDE OF TOP IN DESIRED LOCATION.
- PRE-DRILL HOLES IN TOP TO PREVENT SPLITTING.
- SCREW PENCIL LEDGE TO TOP USING HARDWARE PROVIDED.
- ADJUST LEG LEVELERS TO LEVEL TABLE.
- SEE NEXT PAGE FOR INSTRUCTIONS ON INSTALLING FLUORESCENT LAMPS.

COMPLETE UNIT SHOWN

NOTE:

1.

ALL DIMENSIONS ARE IN INCHES UNLESS NOTED OTHERWISE	DWN BY:	EMR	DATE DWN:	3/4/14
DECIMALS: X = ± .030	APR BY:		DATE APR:	
XX = ± .020	APR BY:		DATE APR:	
XXX = ± .010	APR BY:		DATE APR:	
ANGLES: = ± 1°	APR BY:		DATE APR:	
CABINET SQUARENESS: = ± .0625	APR BY:		DATE APR:	

CONFIDENTIAL:
ALL DESIGN RIGHTS RESERVED
THE INFORMATION, DATA, DESIGN, AND DRAWINGS EMBODIED IN THIS DOCUMENT AND ALL REPRODUCTIONS THEREOF ARE THE EXCLUSIVE PROPERTY OF DIVERSIFIED WOODCRAFTS, INC.

THESE DOCUMENTS ARE SUPPLIED WITH THE UNDERSTANDING THAT THEY WILL NOT BE DISCLOSED TO THIRD PARTIES WITHOUT WRITTEN CONSENT OF DIVERSIFIED WOODCRAFTS, INC. ANY REPRODUCTION IN PART OR WHOLE WITHOUT WRITTEN CONSENT IS SUBJECT TO LEGAL ACTION.



300 South Krueger Street
Suring, WI 54174
diversifiedwoodcrafts.com

TITLE:
**LIGHT TABLE
ASSEMBLY INSTRUCTIONS**

DRAWING NUMBER: LT-4424	SCALE: NTS	SHEET: 8 OF 10	REVISION: REV A
-----------------------------------	---------------	-------------------	--------------------

REV.	DESCRIPTION	DATE	NAME	ECN NO.
A	CREATED ASSEMBLY INSTRUCTIONS	3/4/14	EMR	-
REVISION LEVEL				

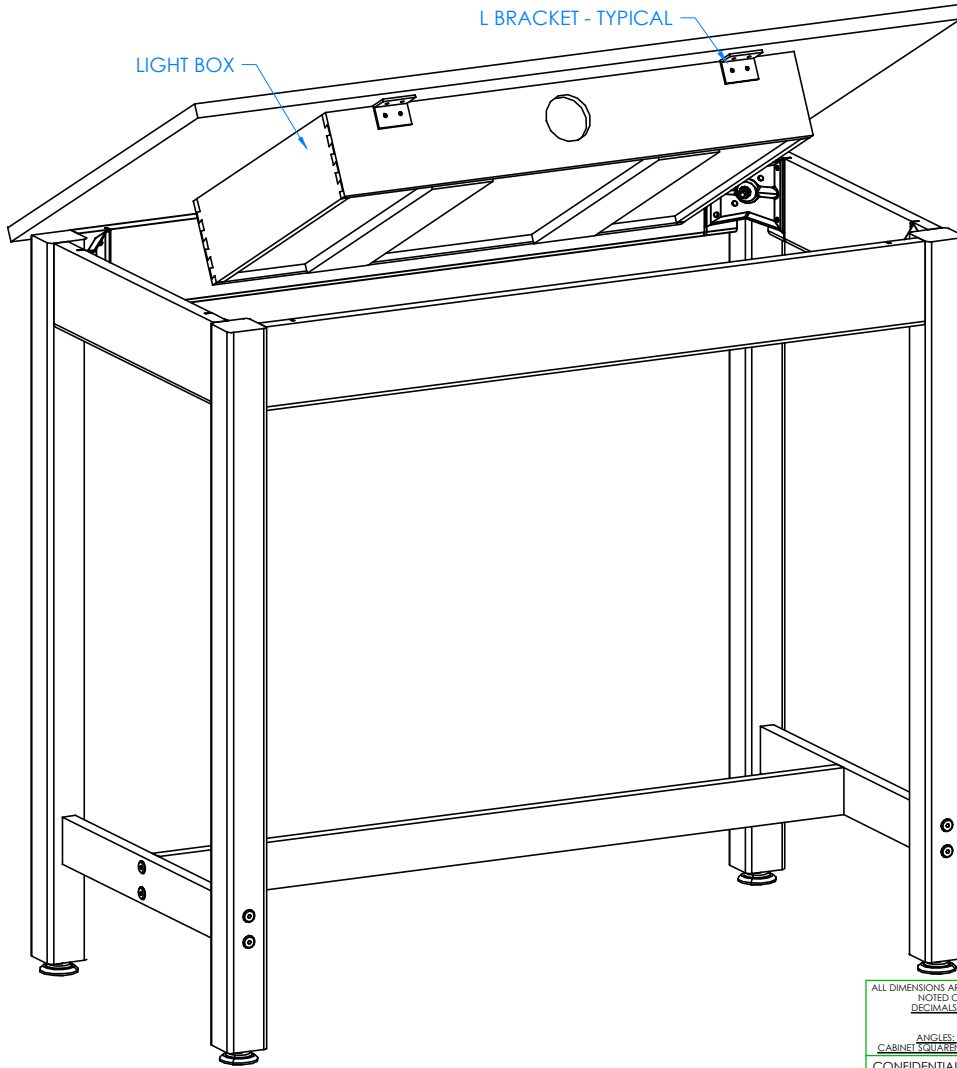

STEP 7:

- OPEN ADJUSTABLE TOP TO ITS MAXIMUM OPENING WIDTH.
- REMOVE SCREWS FROM THE L BRACKETS CONNECTING LIGHT BOX TO TOP.
- THE BOX WILL NOW BE ABLE TO SWING OPEN.
- ****CAUTION**** THE BOX HOUSING THE LIGHTS DOES NOT HAVE A STOPPING MECHANISM IN PLACE. UPON REMOVAL OF THE L BRACKETS FROM THE TOP, THE BOX WILL BE ABLE TO SWING FREELY, AND CAN CAUSE DAMAGE TO TABLE IF NOT SUPPORTED.

NOTE:

1.

SOFT CLOSE AND RATCHET HARDWARE NOT SHOWN

ALL DIMENSIONS ARE IN INCHES UNLESS NOTED OTHERWISE	DWN BY:	EMR	DATE DWN:	3/4/14
DECIMALS: X = ± .030 XX = ± .020 XXX = ± .010	APR BY:		DATE APR:	
ANGLES: = ± 1° CABINET SQUARENESS = ± .0625	APR BY:		DATE APR:	

CONFIDENTIAL:
ALL DESIGN RIGHTS RESERVED
THE INFORMATION, DATA, DESIGN, AND DRAWINGS EMBODIED IN THIS DOCUMENT AND ALL REPRODUCTIONS THEREOF ARE THE EXCLUSIVE PROPERTY OF DIVERSIFIED WOODCRAFTS, INC.

THESE DOCUMENTS ARE SUPPLIED WITH THE UNDERSTANDING THAT THEY WILL NOT BE DISCLOSED TO THIRD PARTIES WITHOUT WRITTEN CONSENT OF DIVERSIFIED WOODCRAFTS, INC. ANY REPRODUCTION IN PART OR WHOLE WITHOUT WRITTEN CONSENT IS SUBJECT TO LEGAL ACTION.



300 South Krueger Street
Suring, WI 54174
diversifiedwoodcrafts.com

TITLE:
LIGHT TABLE
ASSEMBLY INSTRUCTIONS

REV.	DESCRIPTION	DATE	NAME	ECN NO.
A	CREATED ASSEMBLY INSTRUCTIONS	3/4/14	EMR	-

REVISION LEVEL

DRAWING NUMBER:	SCALE:	SHEET:	REVISION:
LT-4424	NTS	9 OF 10	REV A

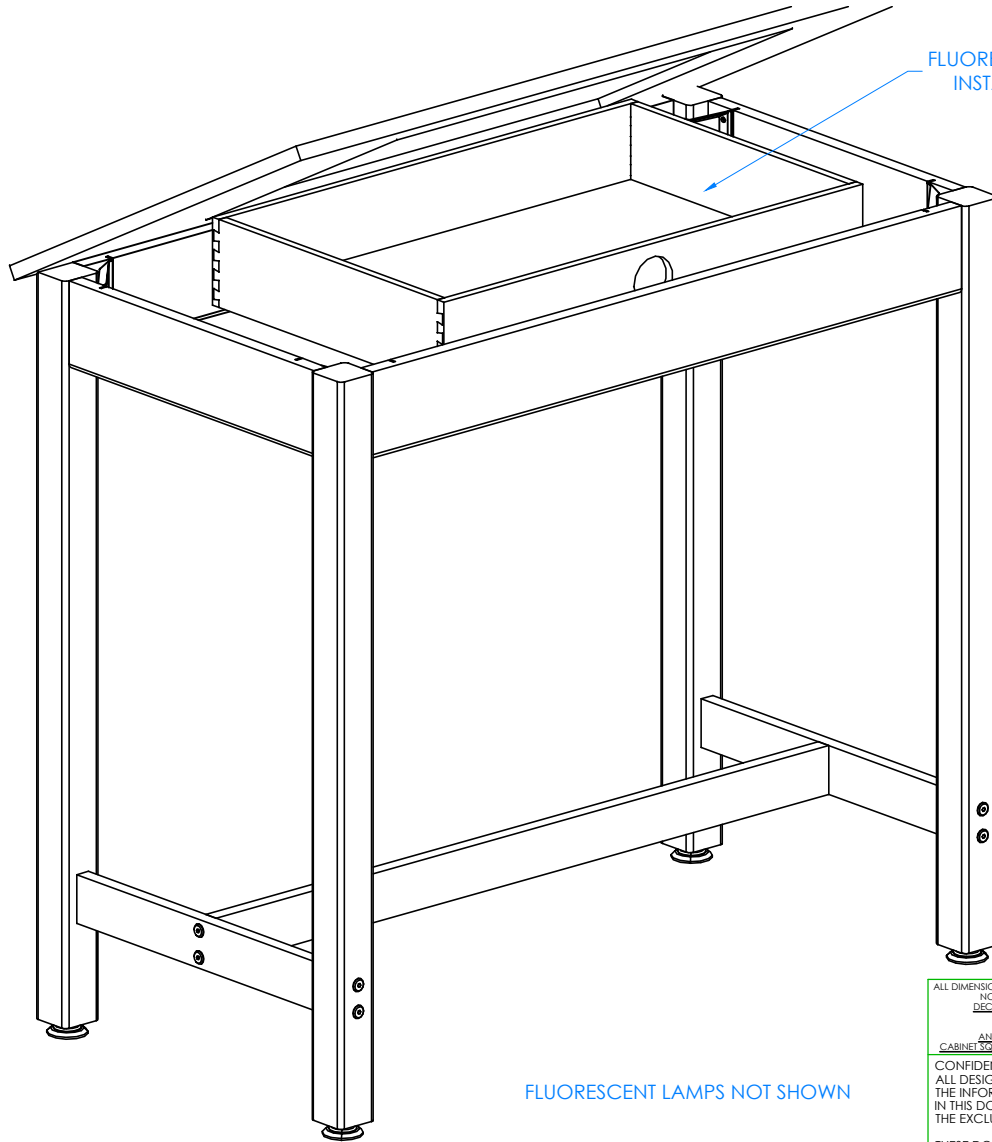

FLUORESCENT LAMPS
INSTALLED HERE

FLUORESCENT LAMPS NOT SHOWN

STEP 8:

- HOUSING FOR THE LIGHTING WILL BE ABLE TO SWING OPEN, ALLOWING ACCESS TO INSTALL OR REPLACE THE LAMPS.
- ONCE LIGHTS ARE INSTALLED, SCREW L BRACKETS BACK INTO TOP.
- MAKE SURE SCREWS ARE TIGHT AND SECURE.

ALL DIMENSIONS ARE IN INCHES UNLESS NOTED OTHERWISE	DWN BY:	EMR	DATE DWN:	3/4/14
DECIMALS: .X = ± .030 .XX = ± .020 .XXX = ± .010	APR BY:		DATE APR:	
ANGLES: = ± 1° CABINET SQUARENESS = ± .0625	APR BY:		DATE APR:	

CONFIDENTIAL:
ALL DESIGN RIGHTS RESERVED
THE INFORMATION, DATA, DESIGN, AND DRAWINGS EMBODIED IN THIS DOCUMENT AND ALL REPRODUCTIONS THEREOF ARE THE EXCLUSIVE PROPERTY OF DIVERSIFIED WOODCRAFTS, INC.

THESE DOCUMENTS ARE SUPPLIED WITH THE UNDERSTANDING THAT THEY WILL NOT BE DISCLOSED TO THIRD PARTIES WITHOUT WRITTEN CONSENT OF DIVERSIFIED WOODCRAFTS, INC. ANY REPRODUCTION IN PART OR WHOLE WITHOUT WRITTEN CONSENT IS SUBJECT TO LEGAL ACTION.



300 South Krueger Street
Suring, WI 54174
diversifiedwoodcrafts.com

TITLE:
LIGHT TABLE
ASSEMBLY INSTRUCTIONS

REV.	DESCRIPTION	DATE	NAME	ECN NO.
A	CREATED ASSEMBLY INSTRUCTIONS	3/4/14	EMR	-
REVISION LEVEL				

DRAWING NUMBER:	SCALE:	SHEET:	REVISION:
LT-4424	NTS	10 OF 10	REV A