

INDUSTRIAL STEEL BENCH

MLB SERIES TABLES ASSEMBLY INSTRUCTIONS

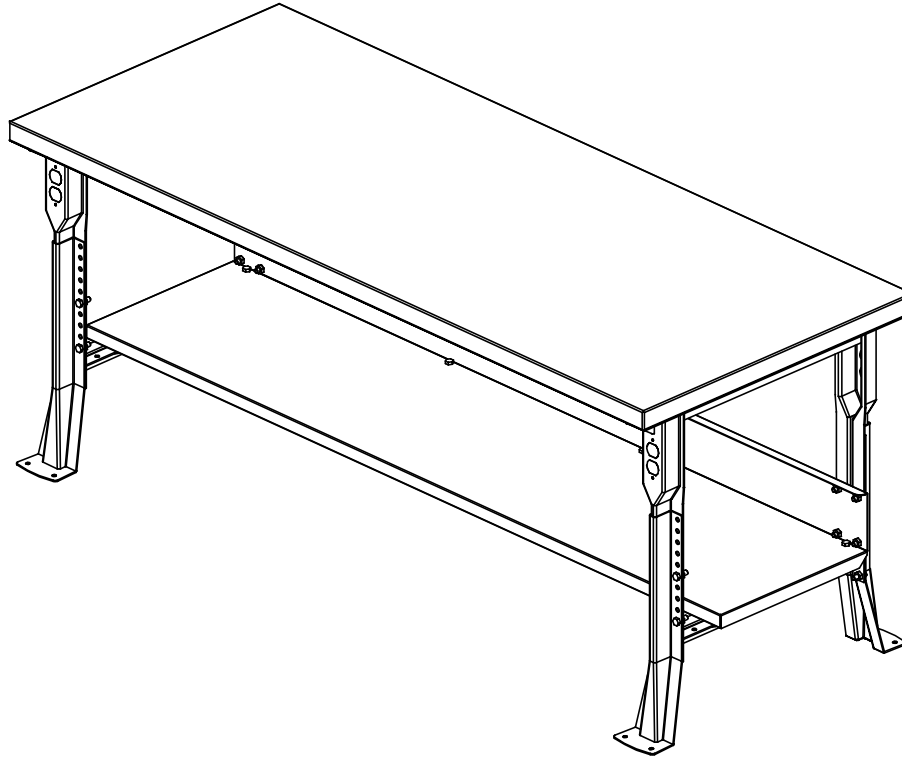

NOTE:

1. MODEL VIEWS MAY NOT REPRESENT EXACT MODEL PURCHASED

ALL DIMENSIONS ARE IN INCHES UNLESS NOTED OTHERWISE	DWN BY:	EMR	DATE DWN:	7/21/21
DECIMALS: X = ± .000	APR BY:		DATE APR:	
XX = ± .020	APR BY:		DATE APR:	
XXX = ± .010	APR BY:		DATE APR:	
ANGLES: = ± 1°	APR BY:		DATE APR:	
CABINET SQUARENESS: = ± .0625	APR BY:		DATE APR:	

CONFIDENTIAL:
ALL DESIGN RIGHTS RESERVED
THE INFORMATION, DATA, DESIGN, AND DRAWINGS EMBODIED IN THIS DOCUMENT AND ALL REPRODUCTIONS THEREOF ARE THE EXCLUSIVE PROPERTY OF DIVERSIFIED WOODCRAFTS, INC.

THESE DOCUMENTS ARE SUPPLIED WITH THE UNDERSTANDING THAT THEY WILL NOT BE DISCLOSED TO THIRD PARTIES WITHOUT WRITTEN CONSENT OF DIVERSIFIED WOODCRAFTS, INC. ANY REPRODUCTION IN PART OR WHOLE WITHOUT WRITTEN CONSENT IS SUBJECT TO LEGAL ACTION.



300 South Krueger Street
Suring, WI 54174
diversifiedwoodcrafts.com

TITLE:
**INDUSTRIAL STEEL BENCH
ASSEMBLY INSTRUCTIONS**

REV.	DESCRIPTION	DATE	NAME	ECN NO.
A	CREATED DRAWING	7/21/21	EMR	-
REVISION LEVEL				

DRAWING NUMBER:	SCALE:	SHEET:	REVISION:
MLB SERIES TABLES	NTS	1 OF 9	REV A

TOOLS REQUIRED

1/2" WRENCH
1/2" SOCKET AND TORQUE WRENCH - OPTIONAL
DRILL
7/32" DRILL BIT FOR TOP ATTACHMENT

ASSEMBLY COMPONENTS

ITEMS INCLUDED	PART #	PART DESCRIPTION	QTY
LEG ASSEMBLY	VARIES	LEG,STEEL,(SIZE AND COLOR VARIES)	VARIES
HARDWARE KIT - LEG ASSEMBLY	257065	HARDWARE BAG, WBML/MLB LEG	1
LEG BRACE	VARIES	BRACE,STEEL,(SIZE AND COLOR VARIES),MATTE/SATIN	VARIES
TOP	VARIES	TOP,(STYLE AND SIZE VARIES)	1
HARDWARE KIT - TOP	20-0050	HARDWARE BAG-WBML/MLB TOP ATTACHMENT	1
HARDWARE KIT - LEG ASSEMBLY FOR 96" TABLES	257072	HARDWARE BAG, WBML/MLB LEG-96" WORKSTATION	1
SHELF	VARIES	SHELF,STEEL(SIZE AND COLOR VARIES)	1
HARDWARE KIT - SHELF	257066	HARDWARE BAG, WBML/MLB SHELF	1

BREAKDOWN OF HARDWARE KITS

HARDWARE KIT - 257065

QTY (24) - 5/16"-18 X 3/4" ZINC FINISH SAE J429 GRADE 5 HEX SERRATED FLANGE BOLT
QTY (24) - 5/16-18 CASE HARDENED ZINC PLATED SERRATED LARGE HEX FLANGE NUT

HARDWARE KIT - 20-0050

QTY (8) -1/4" X 1" LAG BOLTS

HARDWARE KIT - 257072

QTY (12) - 5/16"-18 X 3/4" ZINC FINISH SAE J429 GRADE 5 HEX SERRATED FLANGE BOLT
QTY (12) - 5/16-18 CASE HARDENED ZINC PLATED SERRATED LARGE HEX FLANGE NUT

HARDWARE KIT - 257066

QTY (4) - 5/16"-18 X 3/4" ZINC FINISH SAE J429 GRADE 5 HEX SERRATED FLANGE BOLT
QTY (4) - 5/16-18 CASE HARDENED ZINC PLATED SERRATED LARGE HEX FLANGE NUT
QTY (4) - 1/4"-20 x 1/2" ZINC FINISH SAE J429 GRADE 5 HEX SERRATED FLANGE BOLT
QTY (4) - 1/4-20 CASE HARDENED ZINC PLATED SERRATED LARGE HEX FLANGE NUT

NOTE:

1. COMPONENTS VARY WITH STYLE OF TABLE PURCHASED.
 - 1.1. WIDTHS ARE 48", 60", 72", OR 96"; DEPTHS ARE 24", 30", OR 36".
 - 1.2. FRAME COLORS:
 - 1.2.1. BLACK, WHITE, CARROT, LIME, AQUA, SILVER, LIGHT GREY, OR DARK GREY.
 - 1.2. TOP SELECTIONS:
 - 1.2.1. 1 3/4" BUTCHER BLOCK MAPLE OR SHOPTOP.
2. ****XX**** INDICATES ITEMS THAT MAY NOT COME WITH UNIT (DEPENDING ON MODEL PURCHASED).

A	CREATED DRAWING	7/21/21	EMR	-
REV.	DESCRIPTION	DATE	NAME	ECN NO.
REVISION LEVEL				

ALL DIMENSIONS ARE IN INCHES UNLESS NOTED OTHERWISE DECIMALS: X = ± .000 XX = ± .020 XXX = ± .010 ANGLES: = ± 1° CABINET SQUARENESS: = ± .0625	DWN BY: EMR APR BY: [] APR BY: []	DATE DWN: 7/21/21 DATE APR: [] DATE APR: []
---	---	---

CONFIDENTIAL:
ALL DESIGN RIGHTS RESERVED
THE INFORMATION, DATA, DESIGN, AND DRAWINGS EMBODIED IN THIS DOCUMENT AND ALL REPRODUCTIONS THEREOF ARE THE EXCLUSIVE PROPERTY OF DIVERSIFIED WOODCRAFTS, INC.

THESE DOCUMENTS ARE SUPPLIED WITH THE UNDERSTANDING THAT THEY WILL NOT BE DISCLOSED TO THIRD PARTIES WITHOUT WRITTEN CONSENT OF DIVERSIFIED WOODCRAFTS, INC. ANY REPRODUCTION IN PART OR WHOLE WITHOUT WRITTEN CONSENT IS SUBJECT TO LEGAL ACTION.



300 South Krueger Street
Suring, WI 54174
diversifiedwoodcrafts.com

TITLE: INDUSTRIAL STEEL BENCH TOOLS AND ASSEMBLY COMPONENTS

DRAWING NUMBER: MLB SERIES TABLES	SCALE: NTS	SHEET: 2 OF 9	REVISION: REV A
-----------------------------------	------------	---------------	-----------------

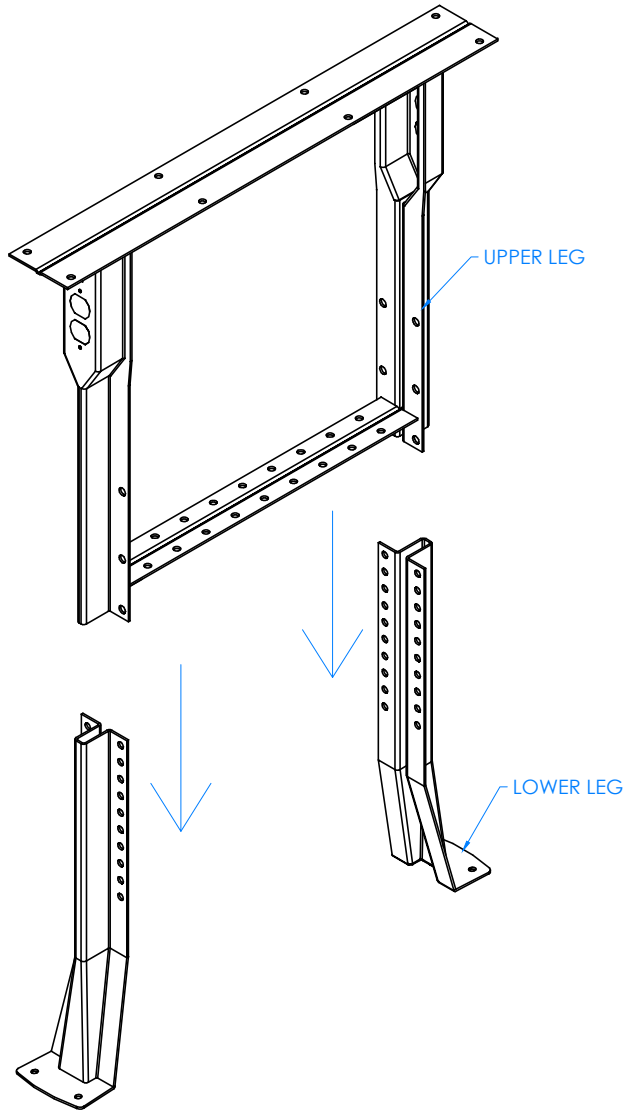

STEP 1:

- SLIDE UPPER LEG DOWN INTO LOWER LEG.
- REPEAT FOR OTHER LEG ASSEMBLIES.

ALL DIMENSIONS ARE IN INCHES UNLESS NOTED OTHERWISE	DWN BY:	EMR	DATE DWN:	7/21/21
DECIMALS: $\times = \pm .000$	APR BY:		DATE APR:	
XX = $\pm .020$	APR BY:		DATE APR:	
XXX = $\pm .010$	APR BY:		DATE APR:	
ANGLES: $= \pm 1^{\circ}0'$	APR BY:		DATE APR:	
CABINET SQUARENESS: $= \pm .0625$	APR BY:		DATE APR:	



300 South Krueger Street
 Suring, WI 54174
 diversifiedwoodcrafts.com

CONFIDENTIAL:
 ALL DESIGN RIGHTS RESERVED
 THE INFORMATION, DATA, DESIGN, AND DRAWINGS EMBODIED IN THIS DOCUMENT AND ALL REPRODUCTIONS THEREOF ARE THE EXCLUSIVE PROPERTY OF DIVERSIFIED WOODCRAFTS, INC.

TITLE:
 INDUSTRIAL STEEL BENCH
 ASSEMBLY INSTRUCTIONS

THESE DOCUMENTS ARE SUPPLIED WITH THE UNDERSTANDING THAT THEY WILL NOT BE DISCLOSED TO THIRD PARTIES WITHOUT WRITTEN CONSENT OF DIVERSIFIED WOODCRAFTS, INC. ANY REPRODUCTION IN PART OR WHOLE WITHOUT WRITTEN CONSENT IS SUBJECT TO LEGAL ACTION.

DRAWING NUMBER:	SCALE:	SHEET:	REVISION:
MLB SERIES TABLES	NTS	3 OF 9	REV A

REV.	DESCRIPTION	DATE	NAME	ECN NO.
A	CREATED DRAWING	7/21/21	EMR	-
REVISION LEVEL				

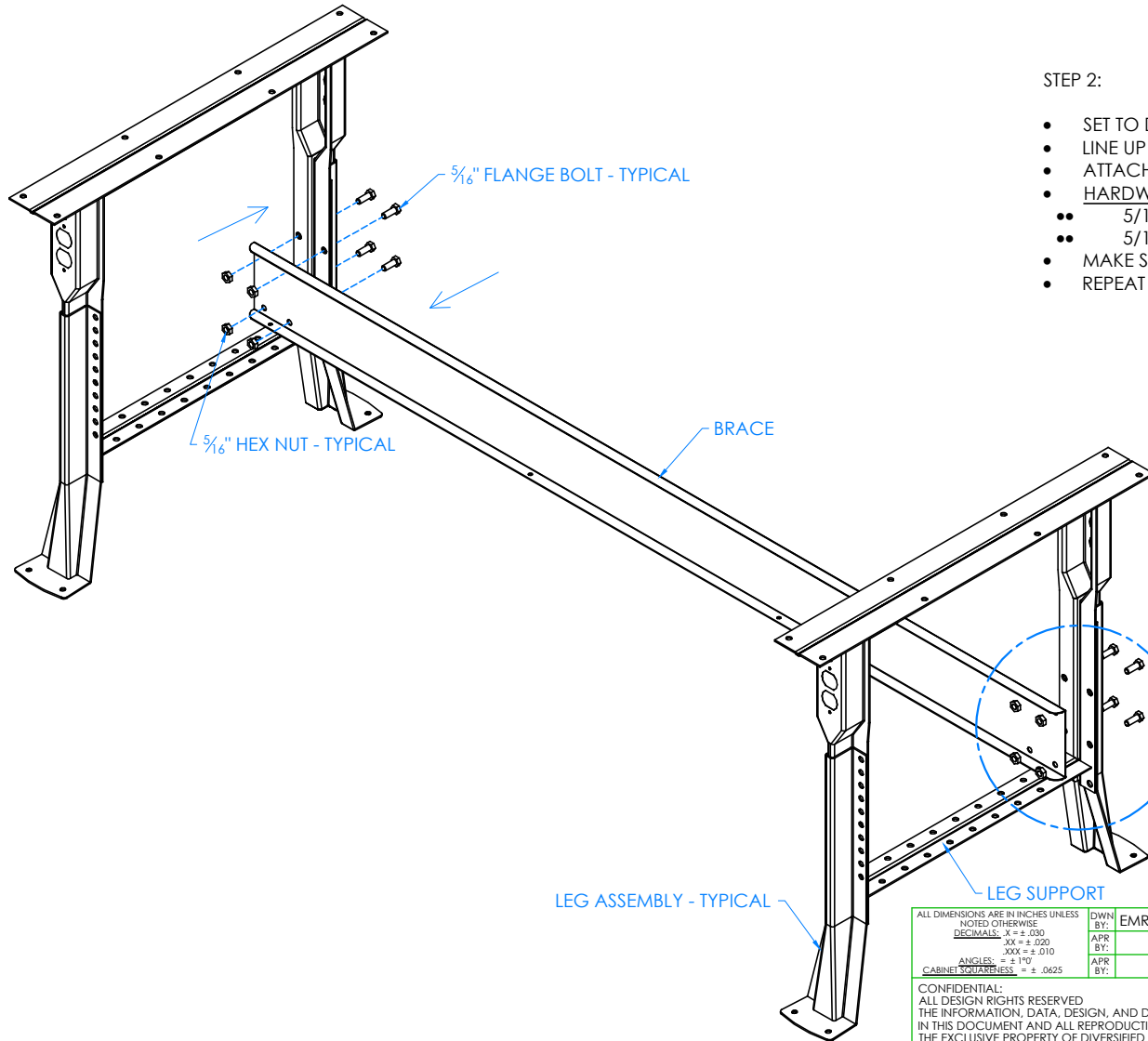

STEP 2:

- SET TO DESIRED HEIGHT - SEE SHEET 5 ON PROPER MOUNTING INSTALLATION!
- LINE UP HOLES ON LEG ASSEMBLIES TO BRACE(S).
- ATTACH BRACE(S) TO LEG ASSEMBLIES WITH HARDWARE PROVIDED.
- HARDWARE USED TO ATTACH LEGS TOGETHER (QUANTITIES VARY!):
 - 5/16"-18 X 3/4" ZINC FINISH FLANGE BOLTS.
 - 5/16-18 CASE HARDENED ZINC PLATED HEX FLANGE NUTS.
- MAKE SURE EACH BOLT IS ON TIGHT!
- REPEAT THIS STEP FOR ALL LEG ASSEMBLIES AND BRACES.

****NOTE****
SEE SHEET 5 ON PROPER MOUNTING INSTALLATION!!

LEG ASSEMBLY - TYPICAL

ALL DIMENSIONS ARE IN INCHES UNLESS NOTED OTHERWISE		DWN BY:	EMR	DATE DWN:	7/21/21
DECIMALS: X = ± .030		APR BY:		DATE APR:	
XX = ± .020		APR BY:		DATE APR:	
XXX = ± .010		APR BY:		DATE APR:	
ANGLES: = ± 1°0'		APR BY:		DATE APR:	
CABINET SQUARENESS: = ± .0625		APR BY:		DATE APR:	

CONFIDENTIAL:
ALL DESIGN RIGHTS RESERVED
THE INFORMATION, DATA, DESIGN, AND DRAWINGS EMBODIED IN THIS DOCUMENT AND ALL REPRODUCTIONS THEREOF ARE THE EXCLUSIVE PROPERTY OF DIVERSIFIED WOODCRAFTS, INC.

THESE DOCUMENTS ARE SUPPLIED WITH THE UNDERSTANDING THAT THEY WILL NOT BE DISCLOSED TO THIRD PARTIES WITHOUT WRITTEN CONSENT OF DIVERSIFIED WOODCRAFTS, INC. ANY REPRODUCTION IN PART OR WHOLE WITHOUT WRITTEN CONSENT IS SUBJECT TO LEGAL ACTION.



300 South Krueger Street
Suring, WI 54174
diversifiedwoodcrafts.com

TITLE:
**INDUSTRIAL STEEL BENCH
ASSEMBLY INSTRUCTIONS**

REV.	DESCRIPTION	DATE	NAME	ECN NO.
A	CREATED DRAWING	7/21/21	EMR	-
REVISION LEVEL				

DRAWING NUMBER:	SCALE:	SHEET:	REVISION:
MLB SERIES TABLES	NTS	4 OF 9	REV A

LEG FRAME MOUNTING INSTRUCTIONS

IMPORTANT: WHEN THE UPPER LEG IS EXTENDED TO A CERTAIN HEIGHT TO WHERE THE FIRST ADJUSTABLE HOLE GOES PAST THE LOWER LEG ADJUSTABLE HOLES, MORE HARDWARE NEEDS TO BE ASSEMBLED. THESE BOLTS AND NUTS NEED TO BE PLACED UNDER THE LEG SUPPORT ON BOTH LEG ASSEMBLIES!!

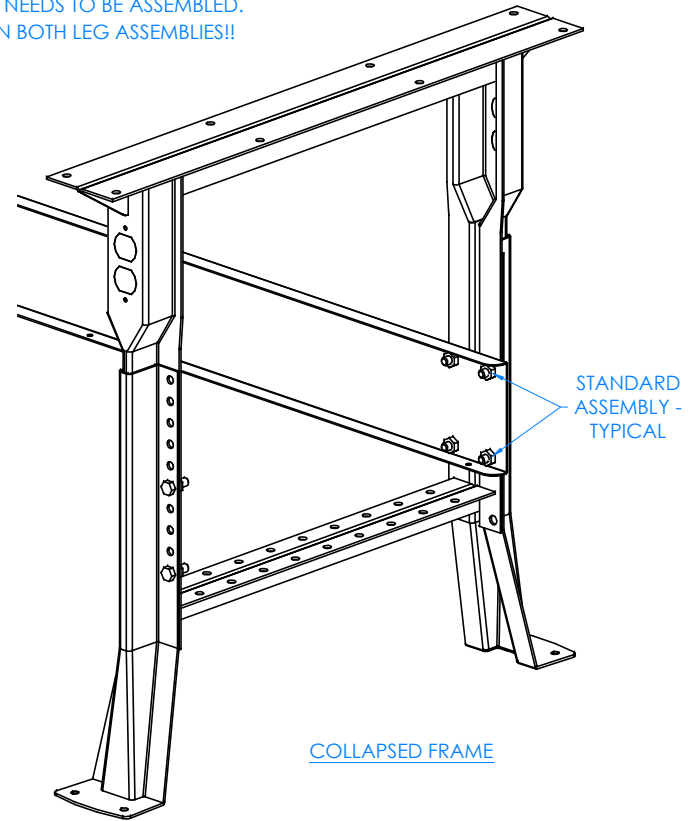
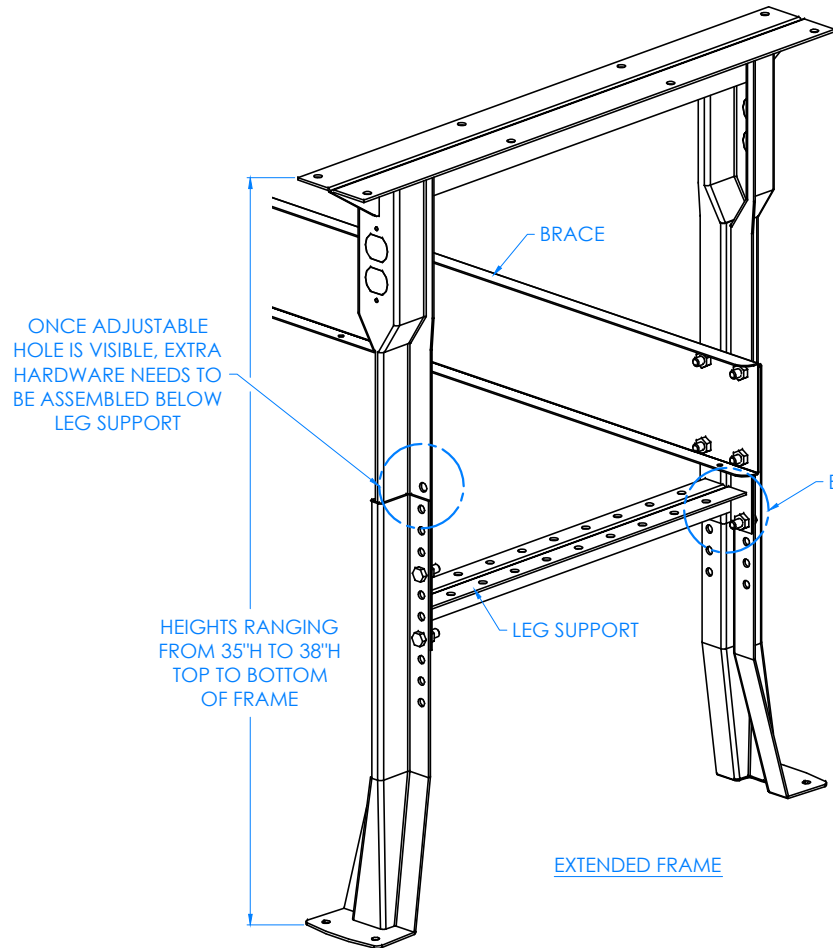

ALL DIMENSIONS ARE IN INCHES UNLESS NOTED OTHERWISE	DWN BY:	EMR	DATE DWN:	7/21/21
DECIMALS: X = ± .000	APR BY:		DATE APR:	
XX = ± .020	APR BY:		DATE APR:	
XXX = ± .010	APR BY:		DATE APR:	
ANGLES: = ± 1°	APR BY:		DATE APR:	
CABINET SQUARENESS: = ± .0625	APR BY:		DATE APR:	

CONFIDENTIAL:
ALL DESIGN RIGHTS RESERVED
THE INFORMATION, DATA, DESIGN, AND DRAWINGS EMBODIED IN THIS DOCUMENT AND ALL REPRODUCTIONS THEREOF ARE THE EXCLUSIVE PROPERTY OF DIVERSIFIED WOODCRAFTS, INC.

THESE DOCUMENTS ARE SUPPLIED WITH THE UNDERSTANDING THAT THEY WILL NOT BE DISCLOSED TO THIRD PARTIES WITHOUT WRITTEN CONSENT OF DIVERSIFIED WOODCRAFTS, INC. ANY REPRODUCTION IN PART OR WHOLE WITHOUT WRITTEN CONSENT IS SUBJECT TO LEGAL ACTION.

300 South Krueger Street
Suring, WI 54174
diversifiedwoodcrafts.com

TITLE:
**INDUSTRIAL STEEL BENCH
ASSEMBLY INSTRUCTIONS**

REV.	DESCRIPTION	DATE	NAME	ECN NO.
A	CREATED DRAWING	7/21/21	EMR	-
REVISION LEVEL				

DRAWING NUMBER:	SCALE:	SHEET:	REVISION:
MLB SERIES TABLES	NTS	5 OF 9	REV A

STEP 3:

- IF YOU DO NOT HAVE A SHELF, SKIP TO STEP 4.
- POSITION SHELF OVER LIP ON BRACE(S).
- ATTACH SHELF TO BRACE(S) AND LEG ASSEMBLIES THROUGH THE (4) HOLES LOCATED ON TOP OF SHELF AND THROUGH HOLES LOCATED ON BOTTOM OF SHELF WITH HARDWARE PROVIDED.
- HARDWARE USED TO ATTACH SHELF:
 - (4) - 5/16"-18 X 3/4" ZINC FINISH FLANGE BOLTS - **FRONT OF SHELF.**
 - (4) - 5/16-18 CASE HARDENED ZINC PLATED HEX FLANGED HEX FLANGE NUTS - **FRONT OF SHELF.**
 - (4) - 1/4"-20 X 1/2" ZINC FINISH FLANGE BOLT - **BACK OF SHELF.**
 - (4) - 1/4-20 CASE HARDENED ZINC PLATED HEX FLANGE NUTS - **BACK OF SHELF.**
- MAKE SURE EACH BOLT IS ON TIGHT!

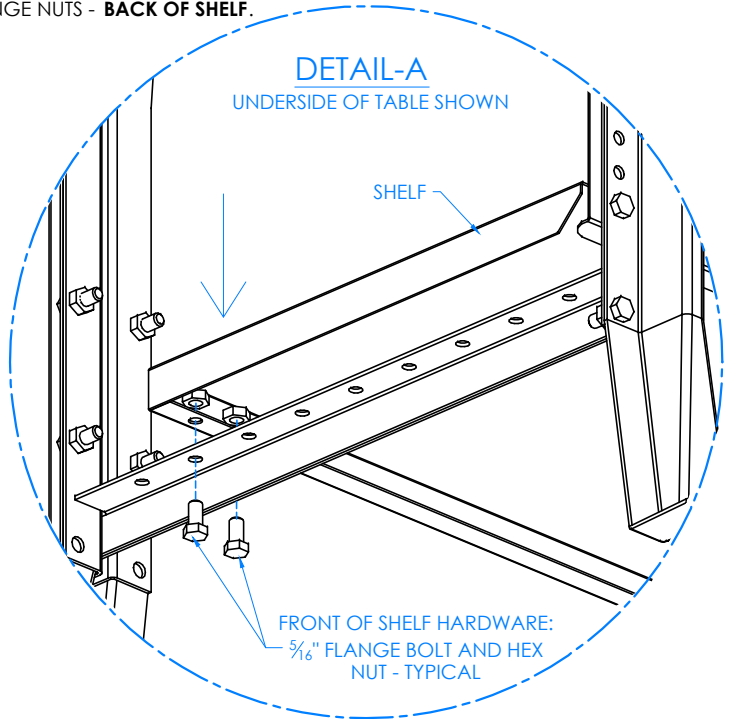
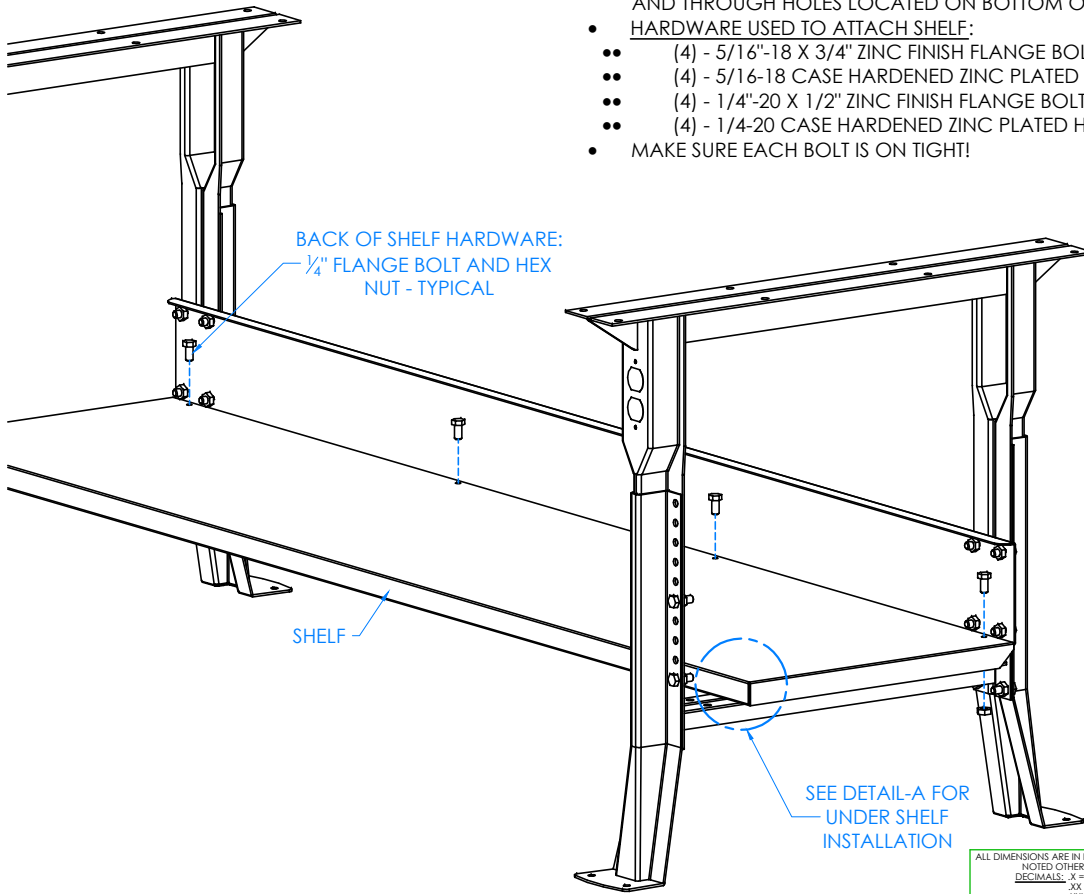

ALL DIMENSIONS ARE IN INCHES UNLESS NOTED OTHERWISE			
DECIMALS:	X = ± .000	DWN BY:	EMR
	XX = ± .020	DATE DWN:	7/21/21
	XXX = ± .010	DATE APR:	
ANGLES:	= ± 1°	DATE APR:	
CABINET SQUARENESS:	= ± .0625	DATE APR:	

CONFIDENTIAL:
 ALL DESIGN RIGHTS RESERVED
 THE INFORMATION, DATA, DESIGN, AND DRAWINGS EMBODIED IN THIS DOCUMENT AND ALL REPRODUCTIONS THEREOF ARE THE EXCLUSIVE PROPERTY OF DIVERSIFIED WOODCRAFTS, INC.

THESE DOCUMENTS ARE SUPPLIED WITH THE UNDERSTANDING THAT THEY WILL NOT BE DISCLOSED TO THIRD PARTIES WITHOUT WRITTEN CONSENT OF DIVERSIFIED WOODCRAFTS, INC. ANY REPRODUCTION IN PART OR WHOLE WITHOUT WRITTEN CONSENT IS SUBJECT TO LEGAL ACTION.



300 South Krueger Street
 Suring, WI 54174
 diversifiedwoodcrafts.com

TITLE:
 INDUSTRIAL STEEL BENCH
 ASSEMBLY INSTRUCTIONS

A	CREATED DRAWING	7/21/21	EMR	-
REV.	DESCRIPTION	DATE	NAME	ECN NO.

REVISION LEVEL

DRAWING NUMBER:	SCALE:	SHEET:	REVISION:
MLB SERIES TABLES	NTS	6 OF 9	REV A

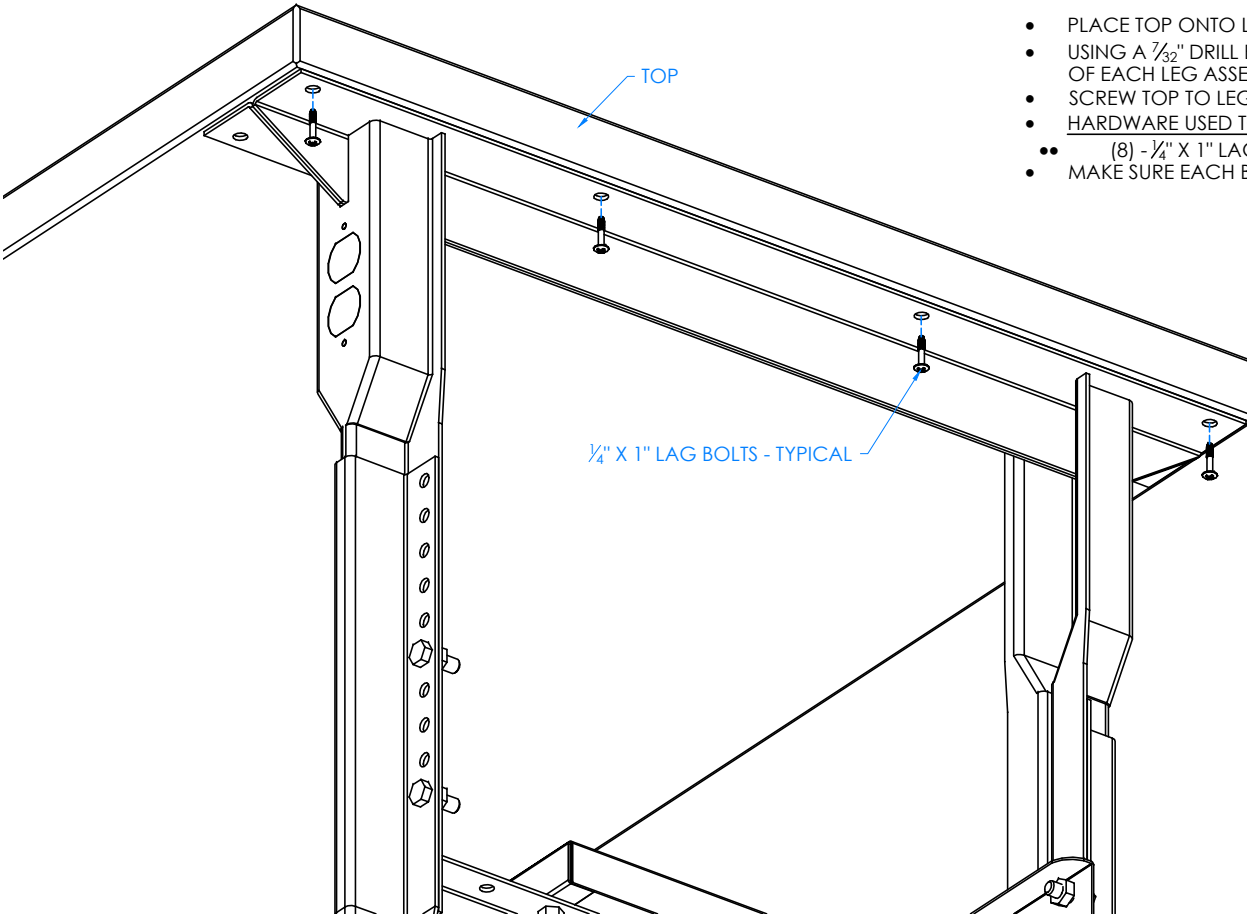

STEP 4:

- PLACE TOP ONTO LEG ASSEMBLIES WITH PROPER OVERHANG (CENTERED ON TABLE).
- USING A 7/32" DRILL BIT, PRE-DRILL HOLES INTO TOP FROM THE SLOTS LOCATED ON TOP OF EACH LEG ASSEMBLY.
- SCREW TOP TO LEG ASSEMBLIES WITH HARDWARE PROVIDED.
- HARDWARE USED TO ATTACH TOP TO LEGS:
 - (8) - 1/4" X 1" LAG BOLTS.
- MAKE SURE EACH BOLT IS ON TIGHT AND TOP IS SECURE!

CLOSE UP OF TOP ASSEMBLY

ALL DIMENSIONS ARE IN INCHES UNLESS NOTED OTHERWISE		DWN BY:	EMR	DATE DWN:	7/21/21
DECIMALS: X = ± .000		APR BY:		DATE APR:	
XX = ± .020		APR BY:		DATE APR:	
XXX = ± .010		APR BY:		DATE APR:	
ANGLES: = ± 1°					
CABINET SQUARENESS: = ± .0625					

CONFIDENTIAL:
 ALL DESIGN RIGHTS RESERVED
 THE INFORMATION, DATA, DESIGN, AND DRAWINGS EMBODIED IN THIS DOCUMENT AND ALL REPRODUCTIONS THEREOF ARE THE EXCLUSIVE PROPERTY OF DIVERSIFIED WOODCRAFTS, INC.

THESE DOCUMENTS ARE SUPPLIED WITH THE UNDERSTANDING THAT THEY WILL NOT BE DISCLOSED TO THIRD PARTIES WITHOUT WRITTEN CONSENT OF DIVERSIFIED WOODCRAFTS, INC. ANY REPRODUCTION IN PART OR WHOLE WITHOUT WRITTEN CONSENT IS SUBJECT TO LEGAL ACTION.



300 South Krueger Street
 Suring, WI 54174
 diversifiedwoodcrafts.com

TITLE:
**INDUSTRIAL STEEL BENCH
 ASSEMBLY INSTRUCTIONS**

REV.	DESCRIPTION	DATE	NAME	ECN NO.
A	CREATED DRAWING	7/21/21	EMR	-
REVISION LEVEL				

DRAWING NUMBER:	SCALE:	SHEET:	REVISION:
MLB SERIES TABLES	NTS	7 OF 9	REV A

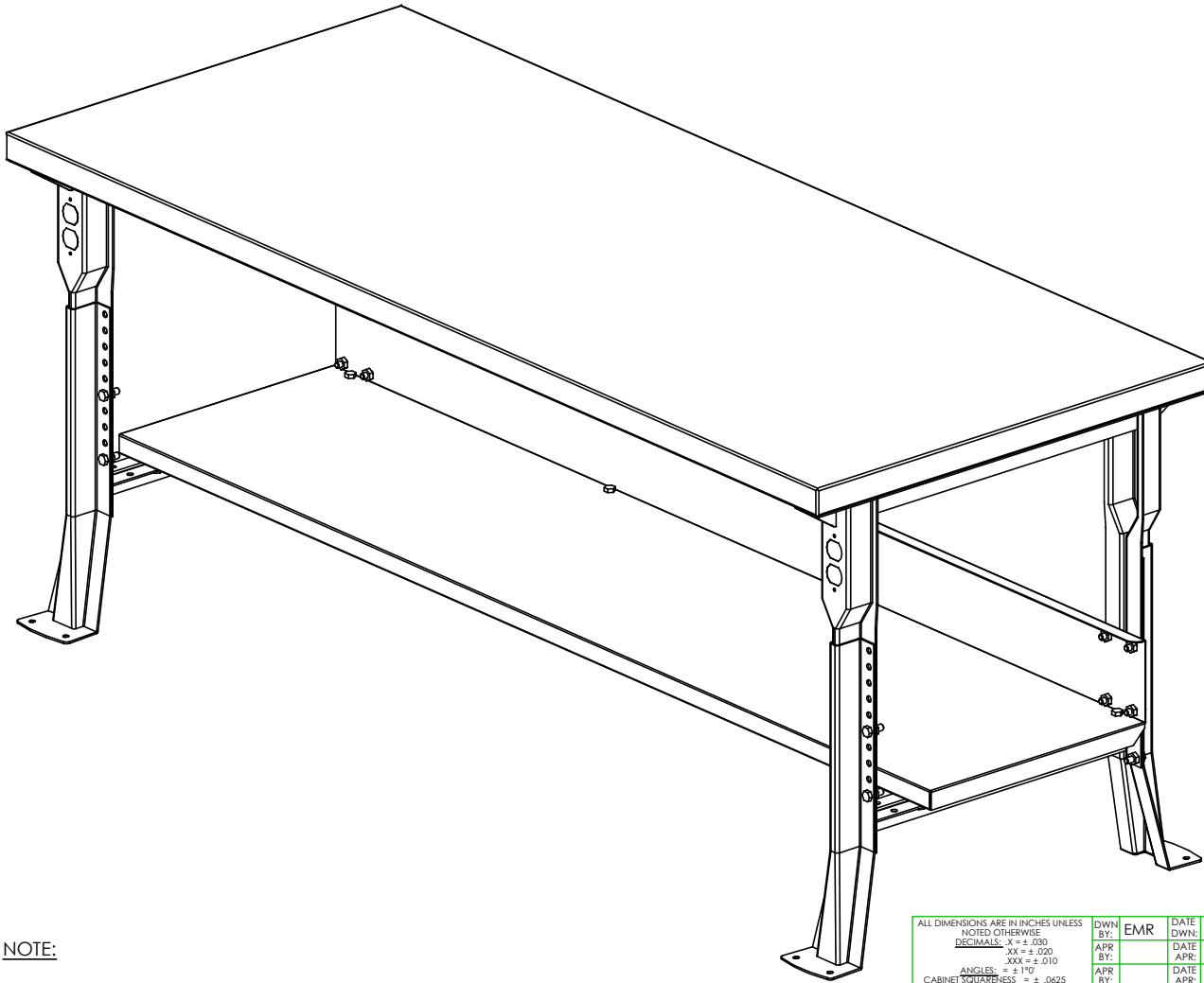

STEP 5:

- SET TABLE IN DESIRED LOCATION.

NOTE:

1. TO INCREASE OR DECREASE HEIGHT OF TABLE; REMOVE BOLTS FROM BRACE AND LEGS. PULL UP OR PUSH DOWN ON ADJUSTABLE LEG. FIND DESIRED HEIGHT AND PLACE BRACE AND BOLTS BACK INTO POSITION.

COMPLETE UNIT SHOWN

ALL DIMENSIONS ARE IN INCHES UNLESS NOTED OTHERWISE	DWN BY:	EMR	DATE DWN:	7/21/21
DECIMALS: X = ± .000	APR BY:		DATE APR:	
XX = ± .020	APR BY:		DATE APR:	
XXX = ± .010	APR BY:		DATE APR:	
ANGLES: = ± 1°	APR BY:		DATE APR:	
CABINET SQUARENESS: = ± .0625	APR BY:		DATE APR:	

CONFIDENTIAL:
 ALL DESIGN RIGHTS RESERVED
 THE INFORMATION, DATA, DESIGN, AND DRAWINGS EMBODIED IN THIS DOCUMENT AND ALL REPRODUCTIONS THEREOF ARE THE EXCLUSIVE PROPERTY OF DIVERSIFIED WOODCRAFTS, INC.

THESE DOCUMENTS ARE SUPPLIED WITH THE UNDERSTANDING THAT THEY WILL NOT BE DISCLOSED TO THIRD PARTIES WITHOUT WRITTEN CONSENT OF DIVERSIFIED WOODCRAFTS, INC. ANY REPRODUCTION IN PART OR WHOLE WITHOUT WRITTEN CONSENT IS SUBJECT TO LEGAL ACTION.



300 South Krueger Street
 Suring, WI 54174
 diversifiedwoodcrafts.com

TITLE:
 INDUSTRIAL STEEL BENCH
 ASSEMBLY INSTRUCTIONS

REV.	DESCRIPTION	DATE	NAME	ECN NO.
A	CREATED DRAWING	7/21/21	EMR	-
REVISION LEVEL				

DRAWING NUMBER:	SCALE:	SHEET:	REVISION:
MLB SERIES TABLES	NTS	8 OF 9	REV A