

# SEWING MACHINE TABLE-SINGLE

SMT-7224  
ASSEMBLY INSTRUCTIONS

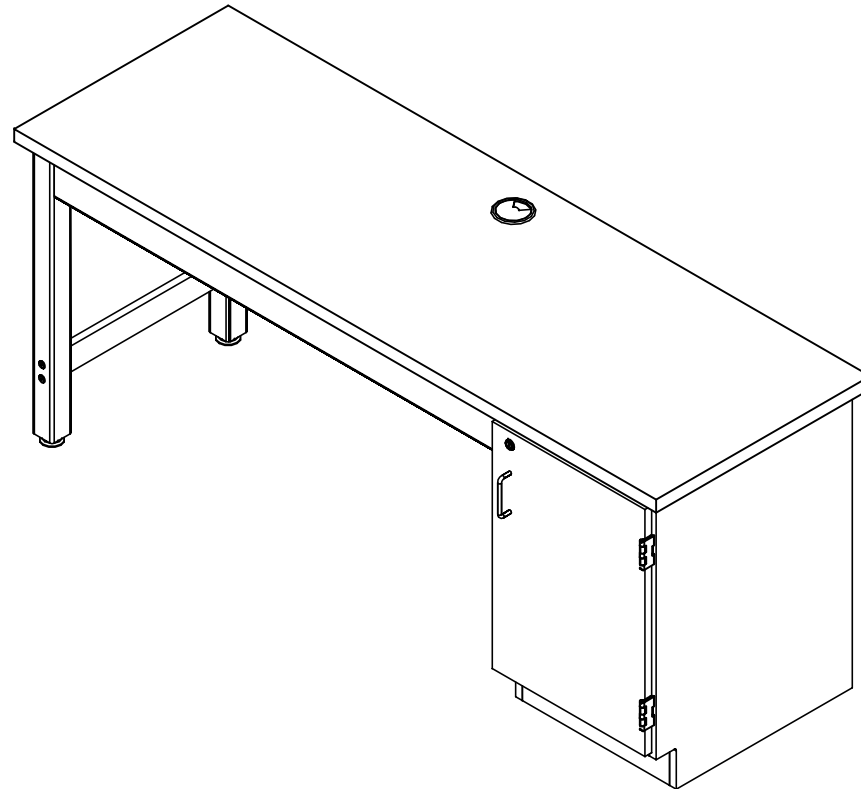

**NOTE:**

1. MODEL VIEWS MAY NOT REPRESENT EXACT MODEL PURCHASED

ALL DIMENSIONS ARE IN INCHES UNLESS NOTED OTHERWISE		DWN BY:	EMR	DATE DWN:	2/21/14
DECIMALS: X = ± .030		APR BY:		DATE APR:	
XX = ± .020		APR BY:		DATE APR:	
XXX = ± .010		APR BY:		DATE APR:	
ANGLES: = ± 1°		APR BY:		DATE APR:	
CABINET SQUARENESS: = ± .0625		APR BY:		DATE APR:	

CONFIDENTIAL:  
ALL DESIGN RIGHTS RESERVED  
THE INFORMATION, DATA, DESIGN, AND DRAWINGS EMBODIED IN THIS DOCUMENT AND ALL REPRODUCTIONS THEREOF ARE THE EXCLUSIVE PROPERTY OF DIVERSIFIED WOODCRAFTS, INC.

THESE DOCUMENTS ARE SUPPLIED WITH THE UNDERSTANDING THAT THEY WILL NOT BE DISCLOSED TO THIRD PARTIES WITHOUT WRITTEN CONSENT OF DIVERSIFIED WOODCRAFTS, INC. ANY REPRODUCTION IN PART OR WHOLE WITHOUT WRITTEN CONSENT IS SUBJECT TO LEGAL ACTION.



300 South Krueger Street  
Suring, WI 54174  
diversifiedwoodcrafts.com

TITLE:  
SEWING MACHINE TABLE - SINGLE  
ASSEMBLY INSTRUCTIONS

DRAWING NUMBER:	SMT-7224	SCALE:	NTS	SHEET:	1 OF 9	REVISION:	REV A
-----------------	----------	--------	-----	--------	--------	-----------	-------

REV.	DESCRIPTION	DATE	NAME	ECN NO.
A	CREATED ASSEMBLY INSTRUCTIONS	2/21/14	EMR	-
REVISION LEVEL				

## TOOLS REQUIRED

CONTACT CEMENT
½" WRENCH
½" SOCKET AND TORQUE WRENCH - OPTIONAL
4MM ALLEN WRENCH
SQUARE BIT DRIVER

## ASSEMBLY COMPONENTS

ITEMS INCLUDED	PART #	PART DESCRIPTION	QTY
TOP	249520	TOP, PLAM, 1.25X24X72, ALMOND	1
SCREWS - TOP	100641	SCREW, #8X1 ¾ QUAD RD WASH HD	10
CABINET ASSEMBLY	N/A	B95 - 29H X 18W X 22D	1
APRON ASSEMBLY	N/A	APRON ASSEMBLY (FACTORY ASSEMBLED)	1
LEGS	501100	LEG, MPL 2.25X2.25X28.25	2
LEG HARDWARE	520001	LEG HARDWARE KIT, 1 LEG	2
BRACE	N/A	BRACE - 0.75"THK X 2.50"W 17.50" L	1
CONFIRMATS - LEGS	227578	SCREW, 7MMX90MM, ALLENHEAD, BLACK	4
SCREWS - INTERNAL APRON	100478	SCREW, #8X1¼" SQ. WASHER FLAT HEAD	3
RUBBER BASE MOLDING	100283	RUBBER BASE MOLDING (SOLD BY FOOT)	7
STAINLESS STEEL CORNERS	100057	CORNERS-STAINLESS STEEL, BASE	4
SCREWS - BASE	100064	SCREW, #6X ½ PTH SMS SS SCREW	16
GROMMETS	100767	GROMMET, 3.125, BLK	1

**NOTE:**

1.

ALL DIMENSIONS ARE IN INCHES UNLESS NOTED OTHERWISE DECIMALS: X = ± .030 XX = ± .020 XXX = ± .010 ANGLES: = ± 1° CABINET SQUARENESS = ± .0625	DWN BY: EMR	DATE DWN: 2/21/14
	APR BY:	DATE APR:
	APR BY:	DATE APR:

CONFIDENTIAL:  
ALL DESIGN RIGHTS RESERVED  
THE INFORMATION, DATA, DESIGN, AND DRAWINGS EMBODIED IN THIS DOCUMENT AND ALL REPRODUCTIONS THEREOF ARE THE EXCLUSIVE PROPERTY OF DIVERSIFIED WOODCRAFTS, INC.

THESE DOCUMENTS ARE SUPPLIED WITH THE UNDERSTANDING THAT THEY WILL NOT BE DISCLOSED TO THIRD PARTIES WITHOUT WRITTEN CONSENT OF DIVERSIFIED WOODCRAFTS, INC. ANY REPRODUCTION IN PART OR WHOLE WITHOUT WRITTEN CONSENT IS SUBJECT TO LEGAL ACTION.



300 South Krueger Street  
Suring, WI 54174  
diversifiedwoodcrafts.com

TITLE:  
SEWING MACHINE TABLE - SINGLE TOOLS AND ASSEMBLY COMPONENTS

REV.	DESCRIPTION	DATE	NAME	ECN NO.
A	CREATED ASSEMBLY INSTRUCTIONS	2/21/14	EMR	-

REVISION LEVEL

DRAWING NUMBER: <b>SMT-7224</b>	SCALE: NTS	SHEET: 2 OF 9	REVISION: REV A
------------------------------------	---------------	------------------	--------------------

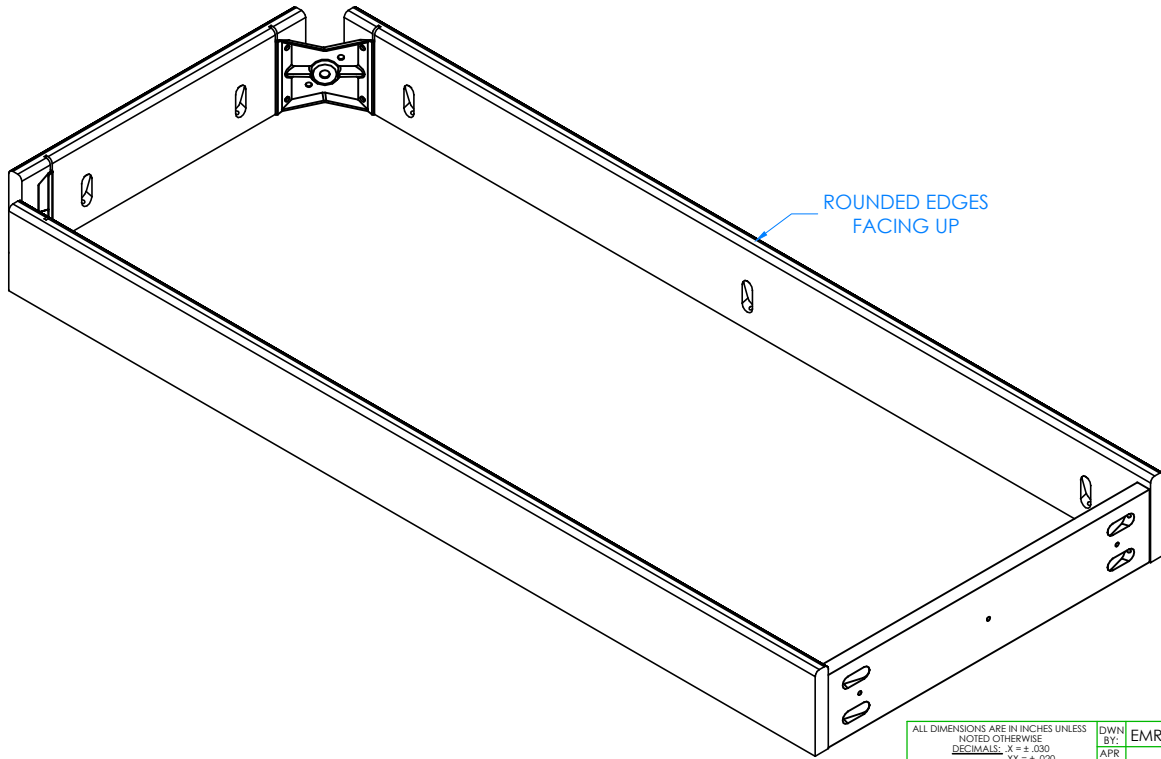

STEP 1:

- LAY APRON ASSEMBLY ON FLOOR WITH ROUNDED EDGES FACING UP.

ALL DIMENSIONS ARE IN INCHES UNLESS NOTED OTHERWISE	DWN BY:	EMR	DATE DWN:	2/21/14
DECIMALS: $\frac{1}{16}$ = ± .030	APR BY:		DATE APR:	
XX = ± .020	APR BY:		DATE APR:	
.XXX = ± .010	APR BY:		DATE APR:	
ANGLES: = ± 1°	APR BY:		DATE APR:	
CABINET SQUARENESS: = ± .0625	APR BY:		DATE APR:	

CONFIDENTIAL:  
 ALL DESIGN RIGHTS RESERVED  
 THE INFORMATION, DATA, DESIGN, AND DRAWINGS EMBODIED IN THIS DOCUMENT AND ALL REPRODUCTIONS THEREOF ARE THE EXCLUSIVE PROPERTY OF DIVERSIFIED WOODCRAFTS, INC.

THESE DOCUMENTS ARE SUPPLIED WITH THE UNDERSTANDING THAT THEY WILL NOT BE DISCLOSED TO THIRD PARTIES WITHOUT WRITTEN CONSENT OF DIVERSIFIED WOODCRAFTS, INC. ANY REPRODUCTION IN PART OR WHOLE WITHOUT WRITTEN CONSENT IS SUBJECT TO LEGAL ACTION.



300 South Krueger Street  
 Suring, WI 54174  
 diversifiedwoodcrafts.com

TITLE:  
**SEWING MACHINE TABLE - SINGLE ASSEMBLY INSTRUCTIONS**

REV.	DESCRIPTION	DATE	NAME	ECN NO.
A	CREATED ASSEMBLY INSTRUCTIONS	2/21/14	EMR	-
REVISION LEVEL				

DRAWING NUMBER:	SCALE:	SHEET:	REVISION:
<b>SMT-7224</b>	NTS	3 OF 9	REV A

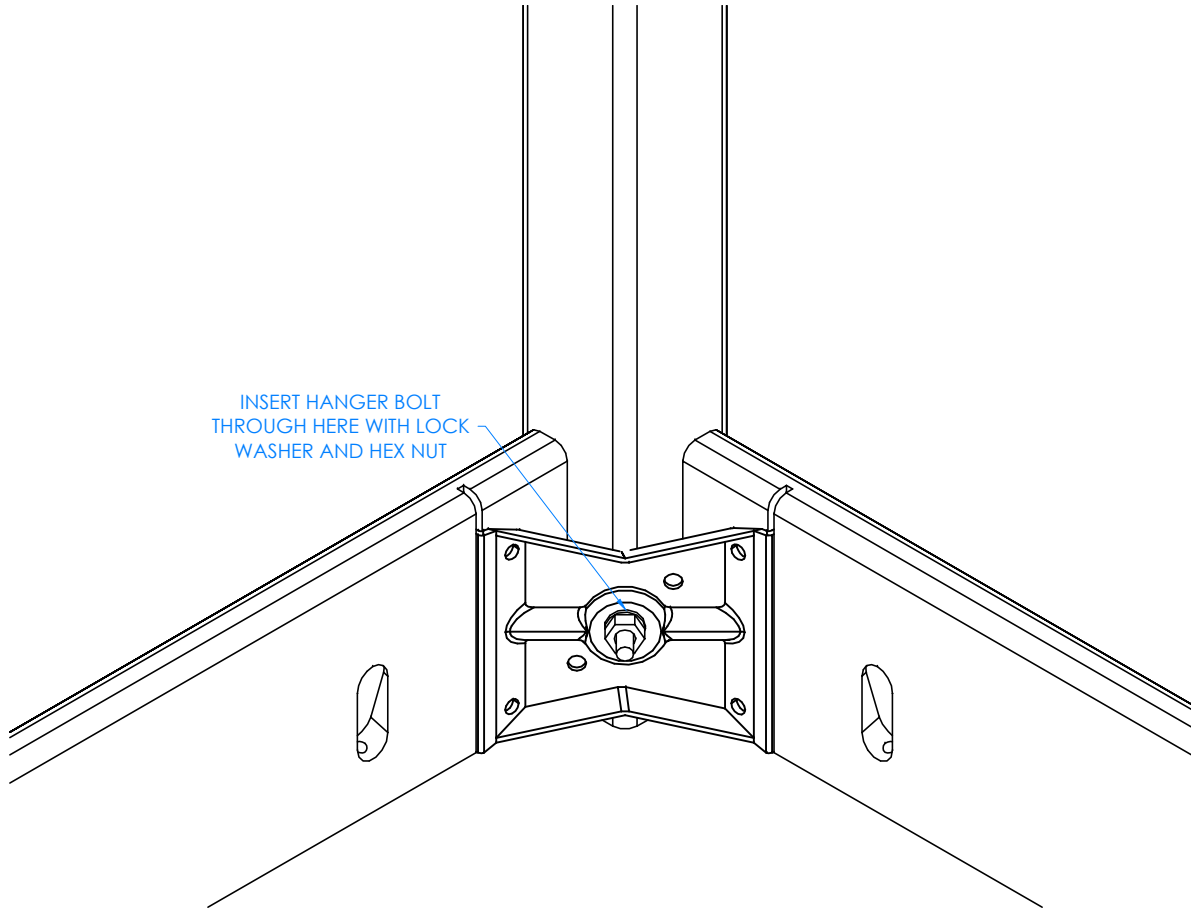

INSERT HANGER BOLT  
THROUGH HERE WITH LOCK  
WASHER AND HEX NUT

CLOSE UP OF CORNER LEG ASSEMBLY

STEP 2:

- INSERT HANGER BOLT ON ONE LEG THROUGH THE CORNER BRACKET AND INSERT LOCK WASHER AND HEX NUT.
- SCREW ON NUT USING A 1/2" WRENCH OR 1/2" SOCKET AND TORQUE WRENCH.
- DO *NOT* TIGHTEN ALL THE WAY.
- REPEAT FOR OTHER LEG.

ALL DIMENSIONS ARE IN INCHES UNLESS NOTED OTHERWISE	DWN BY:	EMR	DATE DWN:	2/21/14
DECIMALS: .X = ± .030 .XX = ± .020 .XXX = ± .010	APR BY:		DATE APR:	
ANGLES: = ± 1° CABINET SQUARENESS = ± .0625	APR BY:		DATE APR:	

CONFIDENTIAL:  
ALL DESIGN RIGHTS RESERVED  
THE INFORMATION, DATA, DESIGN, AND DRAWINGS EMBODIED IN THIS DOCUMENT AND ALL REPRODUCTIONS THEREOF ARE THE EXCLUSIVE PROPERTY OF DIVERSIFIED WOODCRAFTS, INC.

THESE DOCUMENTS ARE SUPPLIED WITH THE UNDERSTANDING THAT THEY WILL NOT BE DISCLOSED TO THIRD PARTIES WITHOUT WRITTEN CONSENT OF DIVERSIFIED WOODCRAFTS, INC. ANY REPRODUCTION IN PART OR WHOLE WITHOUT WRITTEN CONSENT IS SUBJECT TO LEGAL ACTION.



300 South Krueger Street  
Suring, WI 54174  
diversifiedwoodcrafts.com

TITLE:  
SEWING MACHINE TABLE - SINGLE  
ASSEMBLY INSTRUCTIONS

REV.	DESCRIPTION	DATE	NAME	ECN NO.
A	CREATED ASSEMBLY INSTRUCTIONS	2/21/14	EMR	-
REVISION LEVEL				

DRAWING NUMBER:	SCALE:	SHEET:	REVISION:
SMT-7224	NTS	4 OF 9	REV A

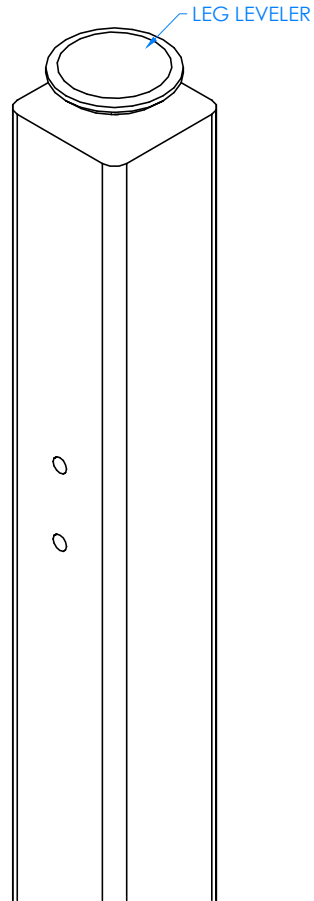

STEP 3:

- SCREW LEG LEVELER INTO T-NUT ON BOTTOM OF LEGS.

CLOSE UP OF LEG LEVELER ASSEMBLY

ALL DIMENSIONS ARE IN INCHES UNLESS NOTED OTHERWISE  
 DECIMALS: X = ± .030  
 XX = ± .020  
 .XXX = ± .010  
 ANGLES: = ± 1°  
 CABINET SQUARENESS: = ± .0625

DWN BY: EMR DATE DWN: 2/21/14  
 APR BY: DATE APR:  
 APR BY: DATE APR:

CONFIDENTIAL:  
 ALL DESIGN RIGHTS RESERVED  
 THE INFORMATION, DATA, DESIGN, AND DRAWINGS EMBODIED IN THIS DOCUMENT AND ALL REPRODUCTIONS THEREOF ARE THE EXCLUSIVE PROPERTY OF DIVERSIFIED WOODCRAFTS, INC.

THESE DOCUMENTS ARE SUPPLIED WITH THE UNDERSTANDING THAT THEY WILL NOT BE DISCLOSED TO THIRD PARTIES WITHOUT WRITTEN CONSENT OF DIVERSIFIED WOODCRAFTS, INC. ANY REPRODUCTION IN PART OR WHOLE WITHOUT WRITTEN CONSENT IS SUBJECT TO LEGAL ACTION.



300 South Krueger Street  
 Suring, WI 54174  
 diversifiedwoodcrafts.com

TITLE:  
 SEWING MACHINE TABLE - SINGLE ASSEMBLY INSTRUCTIONS

DRAWING NUMBER: SMT-7224

SCALE: NTS SHEET: 5 OF 9 REVISION: REV A

REV.	DESCRIPTION	DATE	NAME	ECN NO.
A	CREATED ASSEMBLY INSTRUCTIONS	2/21/14	EMR	-
REVISION LEVEL				

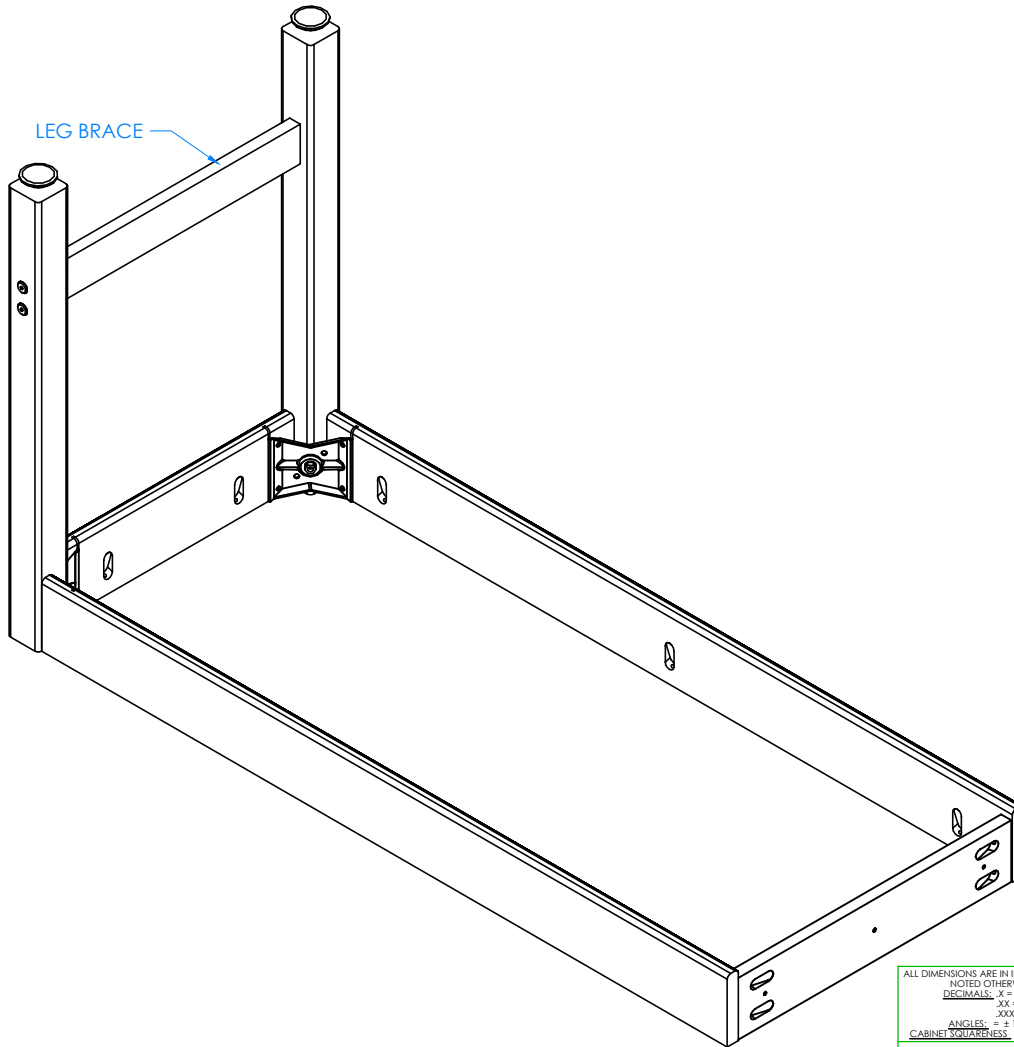

STEP 4:

- ATTACH BRACE TO LEGS.
- INSERT THE CONFIRMATS INTO ONE LEG AND SCREW INTO BRACE.
- REPEAT ON OTHER LEG.
- MAKE SURE BRACE IS STRAIGHT AND ALL CONFIRMATS ARE TIGHT.
- GO BACK TO STEP 2 AND TIGHTEN UP THE HANGER BOLT FOR EACH LEG USING A 1/2" WRENCH OR 1/2" SOCKET AND TORQUE WRENCH, TO A MINIMUM OF 12 FT LBS BUT NOT TO EXCEED 17 FT LBS.

ALL DIMENSIONS ARE IN INCHES UNLESS NOTED OTHERWISE	DWN BY:	EMR	DATE DWN:	2/21/14
DECIMALS: .X = ± .030 .XX = ± .020 .XXX = ± .010	APR BY:		DATE APR:	
ANGLES: = ± 1°	APR BY:		DATE APR:	
CABINET SQUARENESS = ± .0625				

CONFIDENTIAL:  
ALL DESIGN RIGHTS RESERVED  
THE INFORMATION, DATA, DESIGN, AND DRAWINGS EMBODIED IN THIS DOCUMENT AND ALL REPRODUCTIONS THEREOF ARE THE EXCLUSIVE PROPERTY OF DIVERSIFIED WOODCRAFTS, INC.

THESE DOCUMENTS ARE SUPPLIED WITH THE UNDERSTANDING THAT THEY WILL NOT BE DISCLOSED TO THIRD PARTIES WITHOUT WRITTEN CONSENT OF DIVERSIFIED WOODCRAFTS, INC. ANY REPRODUCTION IN PART OR WHOLE WITHOUT WRITTEN CONSENT IS SUBJECT TO LEGAL ACTION.



300 South Krueger Street  
Suring, WI 54174  
diversifiedwoodcrafts.com

TITLE:  
SEWING MACHINE TABLE - SINGLE  
ASSEMBLY INSTRUCTIONS

REV.	DESCRIPTION	DATE	NAME	ECN NO.
A	CREATED ASSEMBLY INSTRUCTIONS	2/21/14	EMR	-
REVISION LEVEL				

DRAWING NUMBER:	SCALE:	SHEET:	REVISION:
SMT-7224	NTS	6 OF 9	REV A

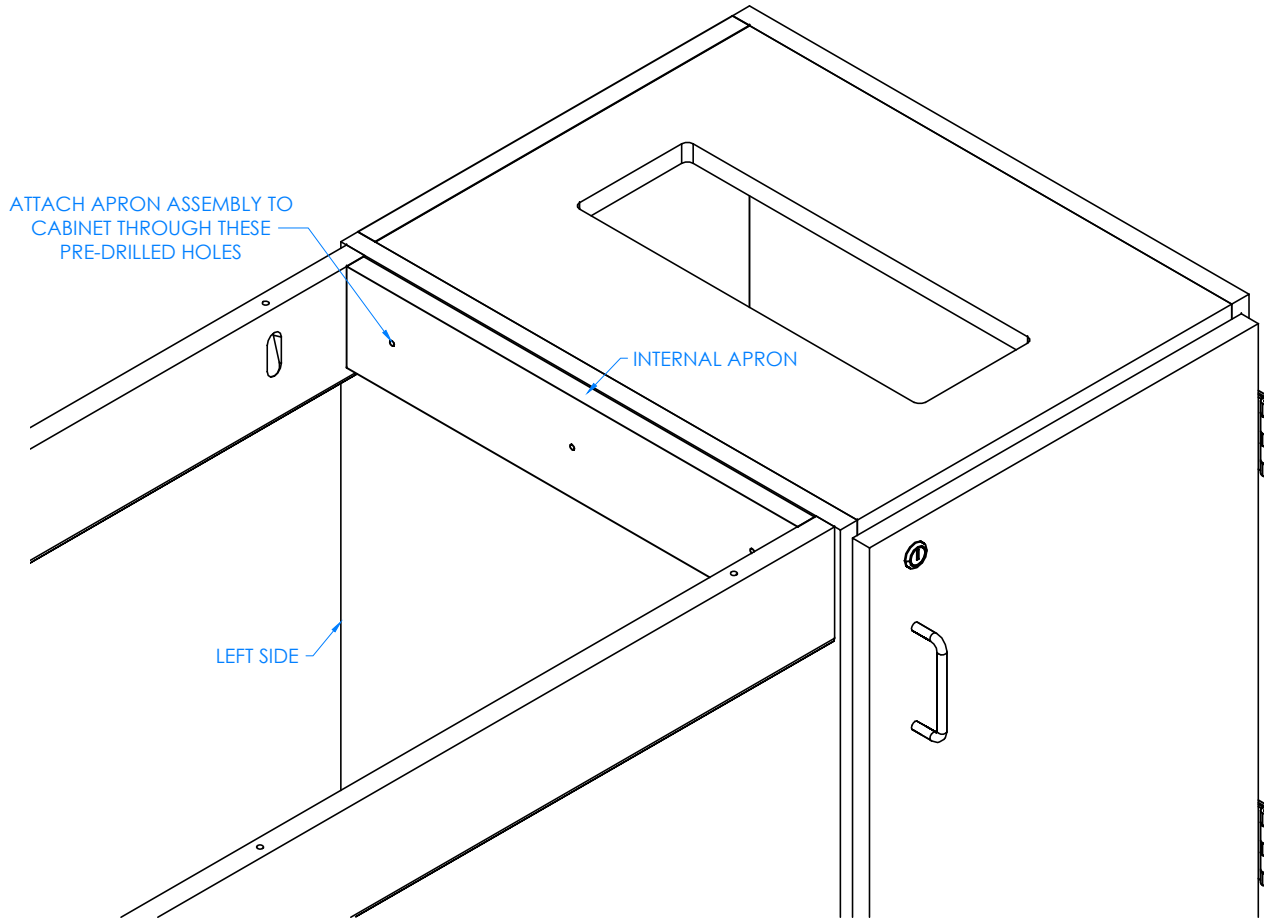

STEP 5:

- WITH HELP FROM ANOTHER PERSON, TURN APRON ASSEMBLY OVER ONTO LEGS.
- ALIGN INTERNAL APRON WITH LEFT SIDE OF CABINET.
- ATTACH TO CABINET WITH HARDWARE PROVIDED USING A SQUARE BIT DRIVER.

CLOSE UP OF APRON ASSEMBLY SHOWN

ALL DIMENSIONS ARE IN INCHES UNLESS NOTED OTHERWISE	DWN BY:	EMR	DATE DWN:	2/21/14
DECIMALS: .X = ± .020 .XX = ± .020 .XXX = ± .010	APR BY:		DATE APR:	
ANGLES: = ± 1° CABINET SQUARENESS = ± .0625	APR BY:		DATE APR:	

CONFIDENTIAL:  
ALL DESIGN RIGHTS RESERVED  
THE INFORMATION, DATA, DESIGN, AND DRAWINGS EMBODIED IN THIS DOCUMENT AND ALL REPRODUCTIONS THEREOF ARE THE EXCLUSIVE PROPERTY OF DIVERSIFIED WOODCRAFTS, INC.

THESE DOCUMENTS ARE SUPPLIED WITH THE UNDERSTANDING THAT THEY WILL NOT BE DISCLOSED TO THIRD PARTIES WITHOUT WRITTEN CONSENT OF DIVERSIFIED WOODCRAFTS, INC. ANY REPRODUCTION IN PART OR WHOLE WITHOUT WRITTEN CONSENT IS SUBJECT TO LEGAL ACTION.



300 South Krueger Street  
Suring, WI 54174  
diversifiedwoodcrafts.com

TITLE:  
SEWING MACHINE TABLE - SINGLE  
ASSEMBLY INSTRUCTIONS

REV.	DESCRIPTION	DATE	NAME	ECN NO.
A	CREATED ASSEMBLY INSTRUCTIONS	2/21/14	EMR	-

REVISION LEVEL

DRAWING NUMBER:

SMT-7224

SCALE:

NTS

SHEET:

7 OF 9

REVISION:

REV A

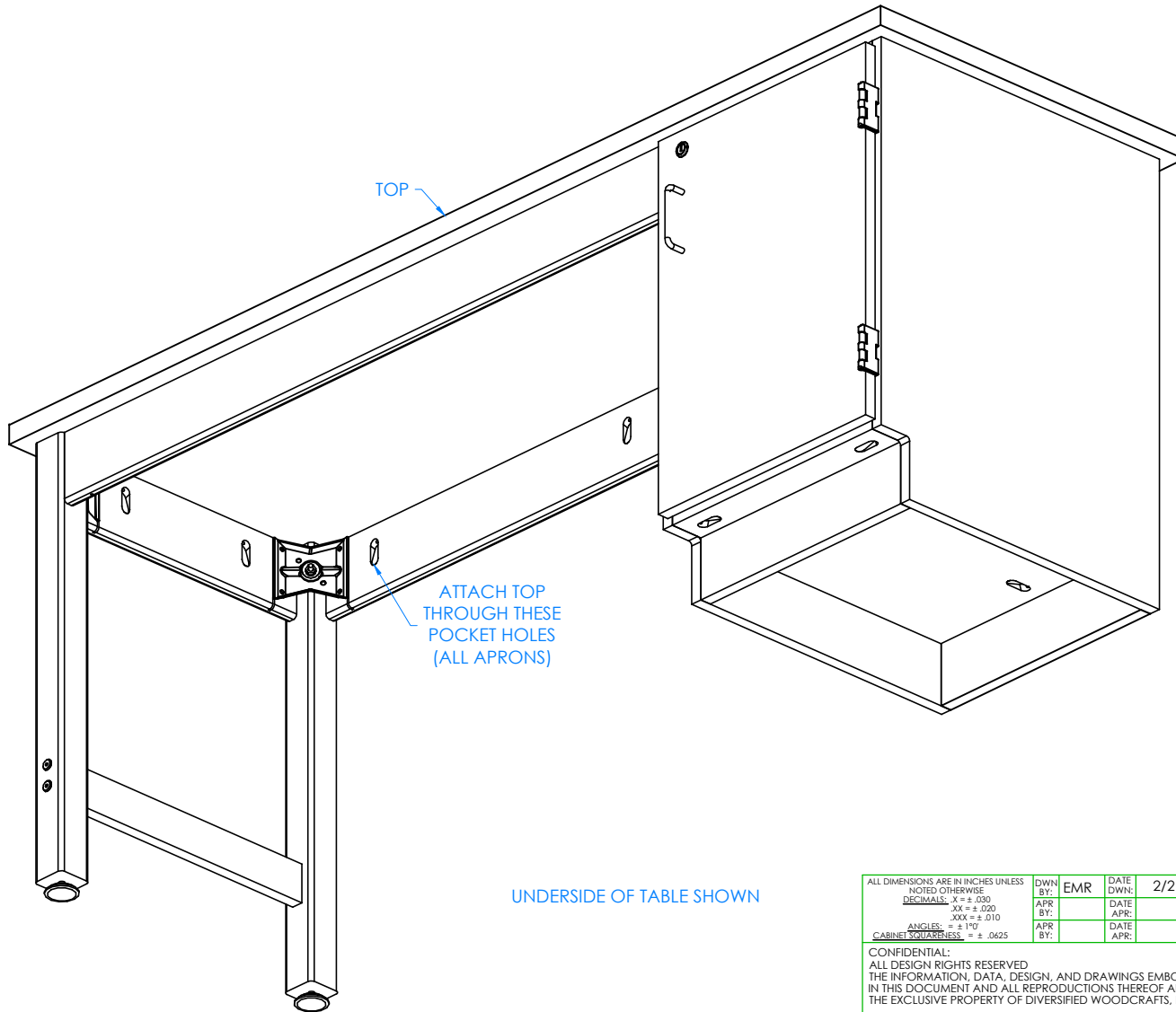

STEP 6:

- PLACE TOP ONTO UNIT WITH PROPER OVERHANG (CENTERED ON TABLE).
- WITH A SQUARE BIT DRIVER, ATTACH TOP TO TABLE BY SCREWING INTO POCKET HOLES LOCATED ON EACH APRON WITH HARDWARE PROVIDED.

UNDERSIDE OF TABLE SHOWN

ALL DIMENSIONS ARE IN INCHES UNLESS NOTED OTHERWISE	DWN BY:	EMR	DATE DWN:	2/21/14
DECIMALS: $\frac{1}{16} = \pm .030$	APR BY:		DATE APR:	
XX = $\pm .020$	APR BY:		DATE APR:	
XXX = $\pm .010$	APR BY:		DATE APR:	
ANGLES: $= \pm 1^{\circ}0$	APR BY:		DATE APR:	
CABINET SQUARENESS: $= \pm .0625$	APR BY:		DATE APR:	

CONFIDENTIAL:  
 ALL DESIGN RIGHTS RESERVED  
 THE INFORMATION, DATA, DESIGN, AND DRAWINGS EMBODIED IN THIS DOCUMENT AND ALL REPRODUCTIONS THEREOF ARE THE EXCLUSIVE PROPERTY OF DIVERSIFIED WOODCRAFTS, INC.

THESE DOCUMENTS ARE SUPPLIED WITH THE UNDERSTANDING THAT THEY WILL NOT BE DISCLOSED TO THIRD PARTIES WITHOUT WRITTEN CONSENT OF DIVERSIFIED WOODCRAFTS, INC. ANY REPRODUCTION IN PART OR WHOLE WITHOUT WRITTEN CONSENT IS SUBJECT TO LEGAL ACTION.



300 South Krueger Street  
 Suring, WI 54174  
 diversifiedwoodcrafts.com

TITLE:  
**SEWING MACHINE TABLE - SINGLE ASSEMBLY INSTRUCTIONS**

REV.	DESCRIPTION	DATE	NAME	ECN NO.
A	CREATED ASSEMBLY INSTRUCTIONS	2/21/14	EMR	-

REVISION LEVEL

DRAWING NUMBER:	SCALE:	SHEET:	REVISION:
<b>SMT-7224</b>	NTS	8 OF 9	REV A



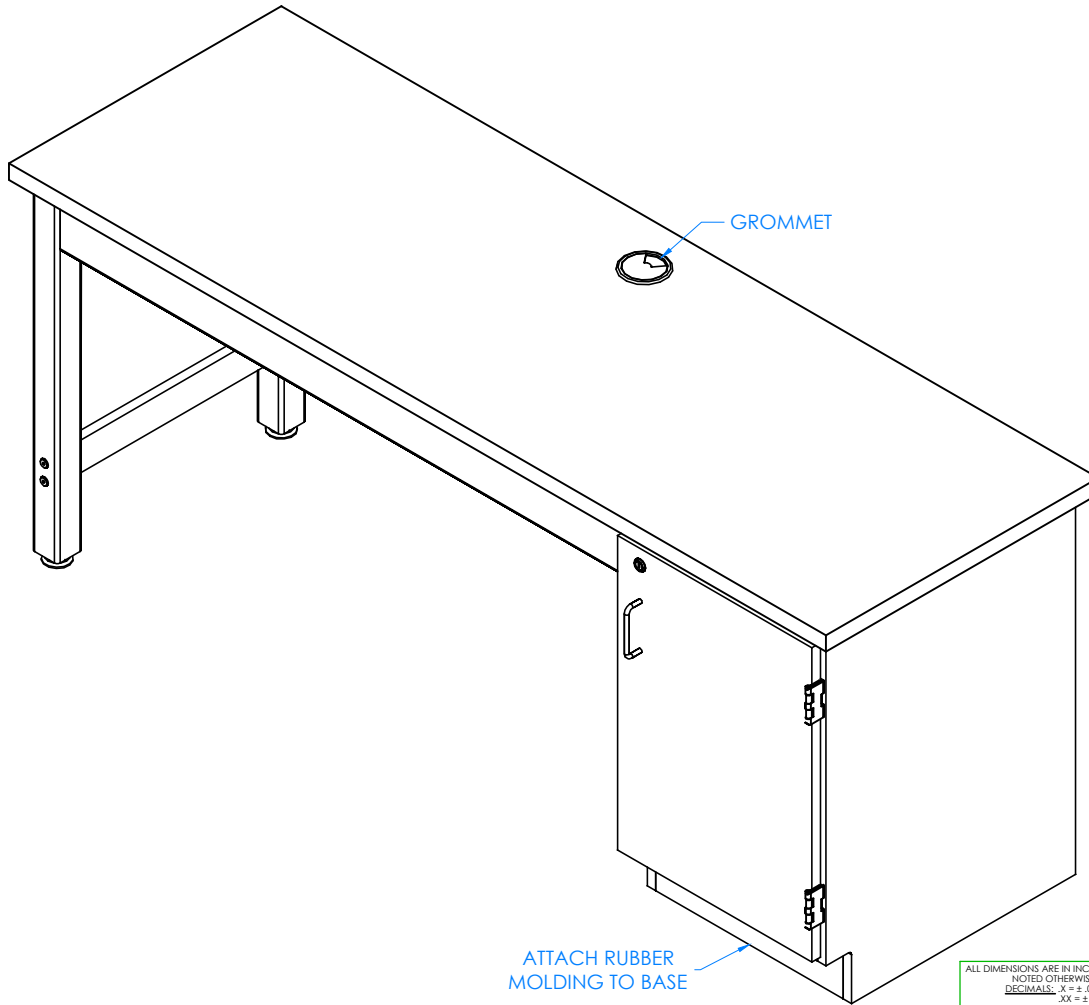

STEP 7:

- ATTACH RUBBER MOLDING TO BASE OF CABINET USING CONTACT CEMENT.
- SCREW STAINLESS STEEL CORNER BRACKETS ON EACH CORNER OVER BASE MOLDING WITH HARDWARE PROVIDED.
- SET TABLE IN PLACE.
- ADJUST LEG LEVELERS TO LEVEL TABLE.
- PLACE GROMMET IN TOP.

ATTACH RUBBER MOLDING TO BASE

COMPLETE UNIT SHOWN

REV.	DESCRIPTION	DATE	NAME	ECN NO.
A	CREATED ASSEMBLY INSTRUCTIONS	2/21/14	EMR	-
REVISION LEVEL				

ALL DIMENSIONS ARE IN INCHES UNLESS NOTED OTHERWISE	DWN BY:	EMR	DATE DWN:	2/21/14
DECIMALS: X = ± .030	APR BY:		DATE APR:	
XX = ± .020	APR BY:		DATE APR:	
XXX = ± .010	APR BY:		DATE APR:	
ANGLES: = ± 1°	APR BY:		DATE APR:	
CABINET SQUARENESS: = ± .0625	APR BY:		DATE APR:	

CONFIDENTIAL:  
ALL DESIGN RIGHTS RESERVED  
THE INFORMATION, DATA, DESIGN, AND DRAWINGS EMBODIED IN THIS DOCUMENT AND ALL REPRODUCTIONS THEREOF ARE THE EXCLUSIVE PROPERTY OF DIVERSIFIED WOODCRAFTS, INC.

THESE DOCUMENTS ARE SUPPLIED WITH THE UNDERSTANDING THAT THEY WILL NOT BE DISCLOSED TO THIRD PARTIES WITHOUT WRITTEN CONSENT OF DIVERSIFIED WOODCRAFTS, INC. ANY REPRODUCTION IN PART OR WHOLE WITHOUT WRITTEN CONSENT IS SUBJECT TO LEGAL ACTION.



300 South Krueger Street  
Suring, WI 54174  
diversifiedwoodcrafts.com

TITLE:  
SEWING MACHINE TABLE - SINGLE  
ASSEMBLY INSTRUCTIONS

DRAWING NUMBER:	SCALE:	SHEET:	REVISION:
SMT-7224	NTS	9 OF 9	REV A