

# SIT-2-STAND DRAFTING TABLE

## SSDT-30 ASSEMBLY INSTRUCTIONS

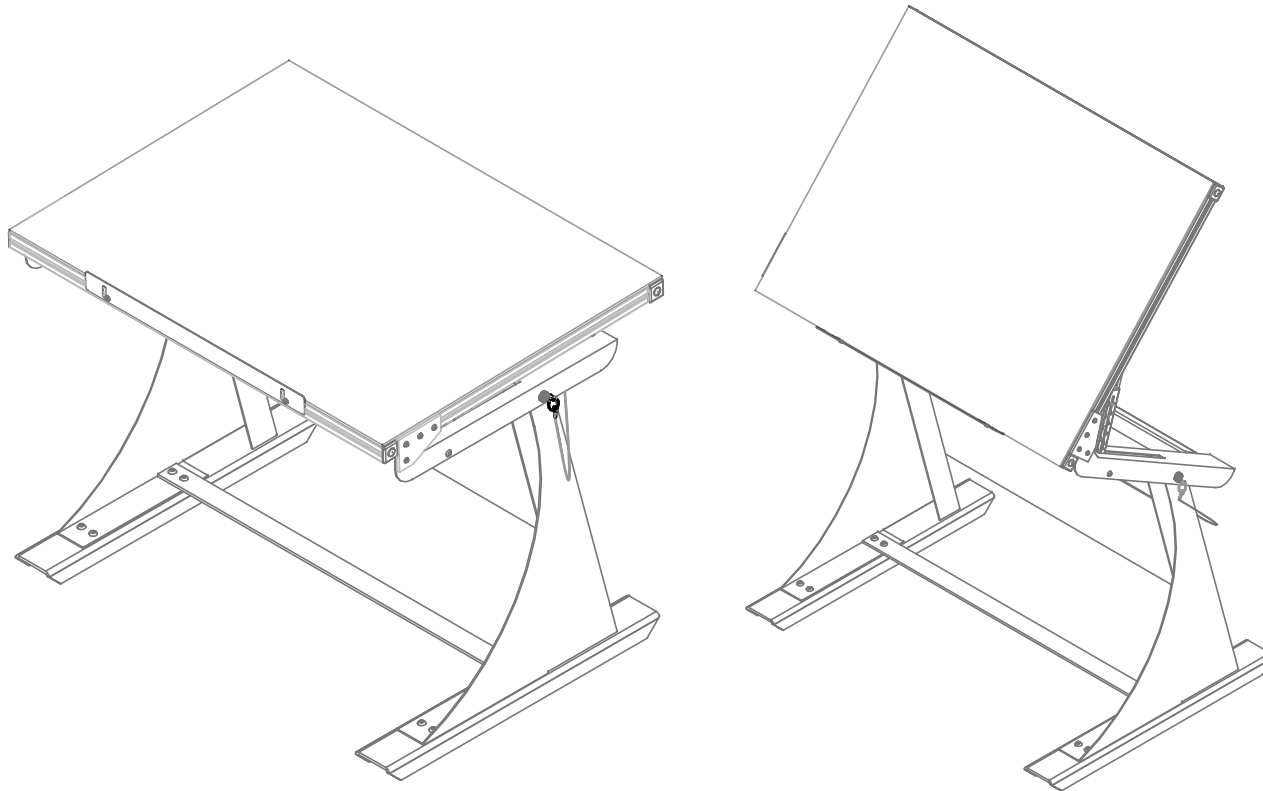

**NOTE:**

1. MODEL VIEWS MAY NOT REPRESENT EXACT MODEL PURCHASED

ALL DIMENSIONS ARE IN INCHES UNLESS NOTED OTHERWISE			
DECIMALS:	X = ± .000	DWN BY:	EMR
	XX = ± .020	DATE DWN:	9/18/18
	XXX = ± .010	DATE APR:	
ANGLES:	= ± 1°	DATE APR:	
CABINET SQUARENESS:	= ± .0625	DATE APR:	

CONFIDENTIAL:  
ALL DESIGN RIGHTS RESERVED  
THE INFORMATION, DATA, DESIGN, AND DRAWINGS EMBODIED IN THIS DOCUMENT AND ALL REPRODUCTIONS THEREOF ARE THE EXCLUSIVE PROPERTY OF DIVERSIFIED WOODCRAFTS, INC.

THESE DOCUMENTS ARE SUPPLIED WITH THE UNDERSTANDING THAT THEY WILL NOT BE DISCLOSED TO THIRD PARTIES WITHOUT WRITTEN CONSENT OF DIVERSIFIED WOODCRAFTS, INC. ANY REPRODUCTION IN PART OR WHOLE WITHOUT WRITTEN CONSENT IS SUBJECT TO LEGAL ACTION.



300 South Krueger Street  
Suring, WI 54174  
diversifiedwoodcrafts.com

TITLE:  
SIT-2-STAND DRAFTING TABLE  
ASSEMBLY INSTRUCTIONS

REV.	DESCRIPTION	DATE	NAME	ECN NO.
A	CREATED DRAWING	9/18/18	EMR	-
REVISION LEVEL				

DRAWING NUMBER:	SSDT-30	SCALE:	NTS	SHEET:	1 OF 15	REVISION:	REV A
-----------------	---------	--------	-----	--------	---------	-----------	-------

### TOOLS REQUIRED

7/32" ALLEN WRENCH
3/16" ALLEN WRENCH
1/2" SOCKET OR WRENCH
1/4" ALLEN WRENCH
9/16" SOCKET OR WRENCH

### ASSEMBLY COMPONENTS

ITEMS INCLUDED	PART #	PART DESCRIPTION	QTY
TOP ASSEMBLY	N/A	TOP ASSEMBLY (FACTORY ASSEMBLED)	1
LEG ASSEMBLY	N/A	LEG ASSEMBLY (FACTORY ASSEMBLED)	2
FOOT BRACE	254239	FOOT BRACE - 0.25"THK x 2"W x 38.88"L	1
KNEE SPACE PANEL	254242	KNEE SPACE PANEL - 0.12"THK x 12"W x 38.50"L	1
SCREWS - KNEE SPACE PANEL	254317	SCREW,BUTTON HEAD HEX,BLACK OXIDE,5/16"-18X1"L	4
NUTS - KNEE SPACE PANEL	254312	NUT,LOCK,5/16"-18,BLACK,STEEL THIN NYLON	4
LEG LEVELER	100079	LEG LEVELER,BLK BASE 1	4

**NOTE:**

1.

ALL DIMENSIONS ARE IN INCHES UNLESS NOTED OTHERWISE DECIMALS: X = ± .030 XX = ± .020 XXX = ± .010 ANGLES: = ± 1° CABINET SQUARENESS: = ± .0625	DWN BY: EMR	DATE DWN: 9/18/18
	APR BY:	DATE APR:
	APR BY:	DATE APR:

CONFIDENTIAL:  
ALL DESIGN RIGHTS RESERVED  
THE INFORMATION, DATA, DESIGN, AND DRAWINGS EMBODIED IN THIS DOCUMENT AND ALL REPRODUCTIONS THEREOF ARE THE EXCLUSIVE PROPERTY OF DIVERSIFIED WOODCRAFTS, INC.

THESE DOCUMENTS ARE SUPPLIED WITH THE UNDERSTANDING THAT THEY WILL NOT BE DISCLOSED TO THIRD PARTIES WITHOUT WRITTEN CONSENT OF DIVERSIFIED WOODCRAFTS, INC. ANY REPRODUCTION IN PART OR WHOLE WITHOUT WRITTEN CONSENT IS SUBJECT TO LEGAL ACTION.



300 South Krueger Street  
Suring, WI 54174  
diversifiedwoodcrafts.com

TITLE:  
SIT-2-STAND DRAFTING TABLE  
TOOLS AND ASSEMBLY COMPONENTS

REV.	DESCRIPTION	DATE	NAME	ECN NO.
A	CREATED DRAWING	9/18/18	EMR	-

REVISION LEVEL

DRAWING NUMBER: <b>SSDT-30</b>	SCALE: NTS	SHEET: 2 OF 15	REVISION: REV A
-----------------------------------	---------------	-------------------	--------------------

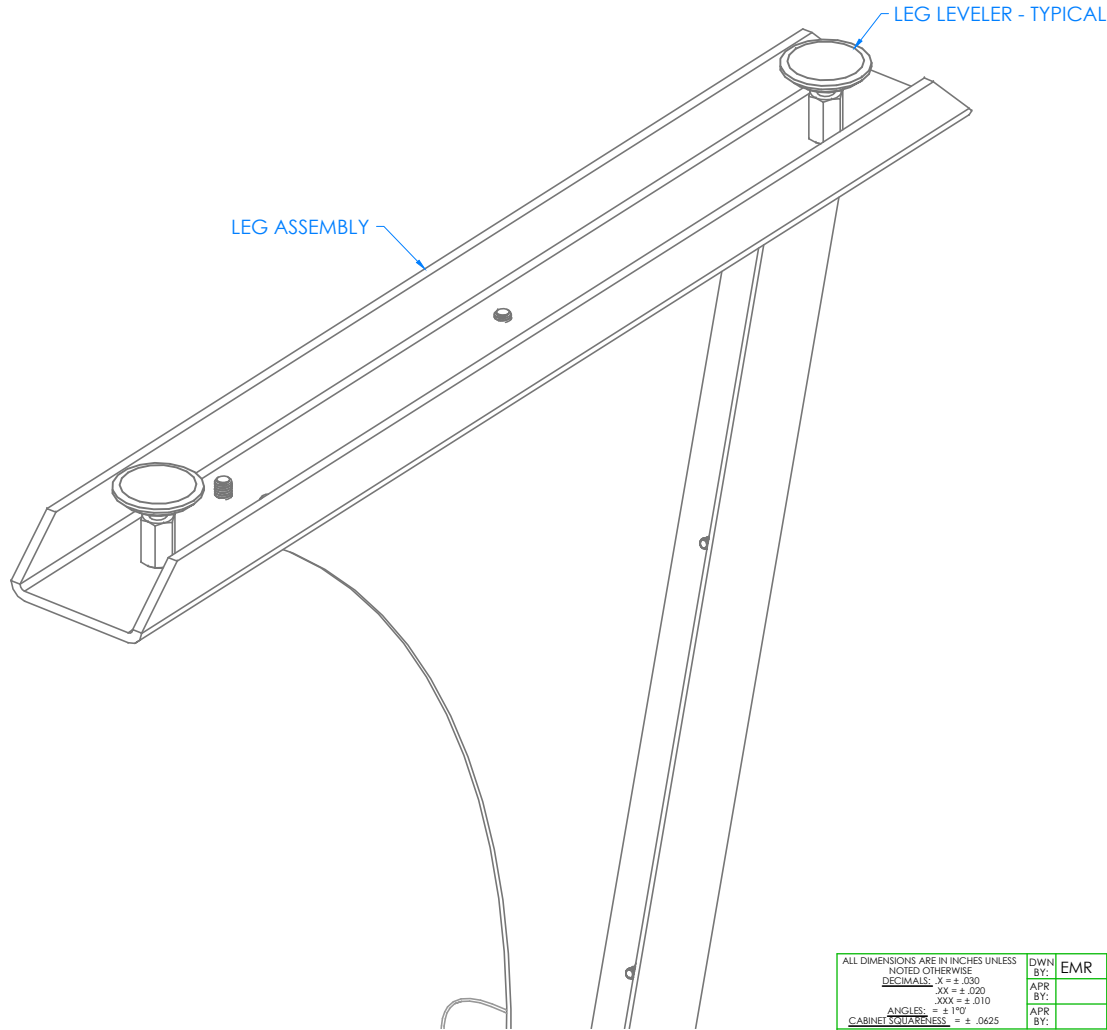

STEP 1:

- TURN LEG ASSEMBLIES OVER.
- SCREW LEG LEVELERS INTO BOTTOM OF LEGS.

CLOSE UP OF LEG LEVELER ASSEMBLY SHOWN

ALL DIMENSIONS ARE IN INCHES UNLESS NOTED OTHERWISE	DWN BY:	EMR	DATE DWN:	9/18/18
DECIMALS: $X = \pm .000$	APR BY:		DATE APR:	
$XX = \pm .020$	APR BY:		DATE APR:	
$XXX = \pm .010$	APR BY:		DATE APR:	
ANGLES: $= \pm 1^{\circ}0'$	APR BY:		DATE APR:	
CABINET SQUARENESS: $= \pm .0625$	APR BY:		DATE APR:	

CONFIDENTIAL:  
 ALL DESIGN RIGHTS RESERVED  
 THE INFORMATION, DATA, DESIGN, AND DRAWINGS EMBODIED IN THIS DOCUMENT AND ALL REPRODUCTIONS THEREOF ARE THE EXCLUSIVE PROPERTY OF DIVERSIFIED WOODCRAFTS, INC.

THESE DOCUMENTS ARE SUPPLIED WITH THE UNDERSTANDING THAT THEY WILL NOT BE DISCLOSED TO THIRD PARTIES WITHOUT WRITTEN CONSENT OF DIVERSIFIED WOODCRAFTS, INC. ANY REPRODUCTION IN PART OR WHOLE WITHOUT WRITTEN CONSENT IS SUBJECT TO LEGAL ACTION.



300 South Krueger Street  
 Suring, WI 54174  
 diversifiedwoodcrafts.com

TITLE:  
 SIT-2-STAND DRAFTING TABLE  
 ASSEMBLY INSTRUCTIONS

REV.	DESCRIPTION	DATE	NAME	ECN NO.
A	CREATED DRAWING	9/18/18	EMR	-

REVISION LEVEL

DRAWING NUMBER:	SCALE:	SHEET:	REVISION:
SSDT-30	NTS	3 OF 15	REV A

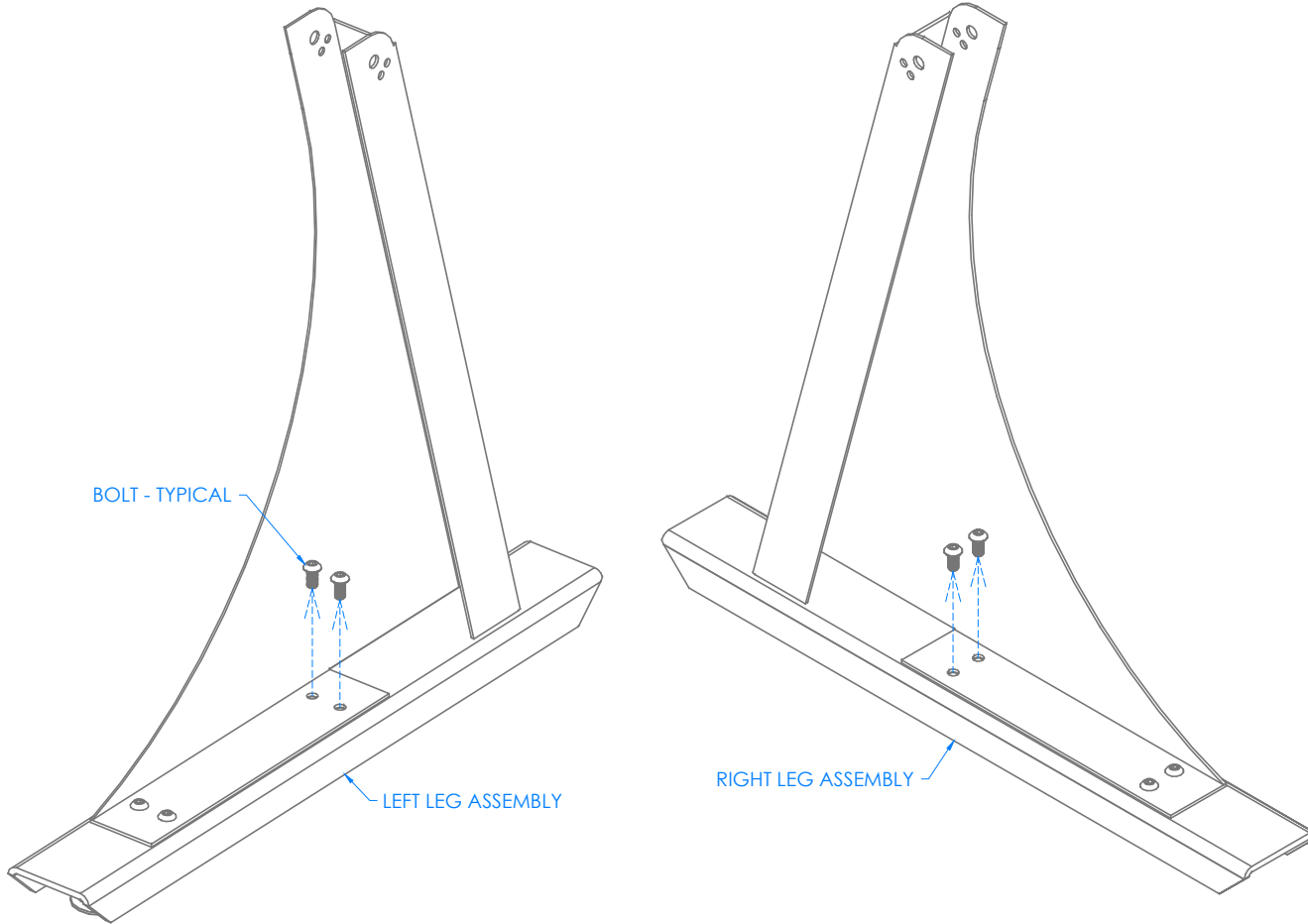

STEP 2:

- WITH A  $\frac{7}{32}$ " ALLEN WRENCH, TAKE THE TWO BOLTS LOCATED TOWARDS BACK OF LEG ASSEMBLIES OUT.
- SET ASIDE.

ALL DIMENSIONS ARE IN INCHES UNLESS NOTED OTHERWISE	DWN BY:	EMR	DATE DWN:	9/18/18
DECIMALS: $\times = \pm .000$	APR BY:		DATE APR:	
$XX = \pm .020$	APR BY:		DATE APR:	
$XXX = \pm .010$	APR BY:		DATE APR:	
ANGLES: $= \pm 1^{\circ}0'$	APR BY:		DATE APR:	
CABINET SQUARENESS: $= \pm .0625$	APR BY:		DATE APR:	

 300 South Krueger Street  
 Suring, WI 54174  
 diversifiedwoodcrafts.com

CONFIDENTIAL:  
 ALL DESIGN RIGHTS RESERVED  
 THE INFORMATION, DATA, DESIGN, AND DRAWINGS EMBODIED IN THIS DOCUMENT AND ALL REPRODUCTIONS THEREOF ARE THE EXCLUSIVE PROPERTY OF DIVERSIFIED WOODCRAFTS, INC.

TITLE:  
 SIT-2-STAND DRAFTING TABLE  
 ASSEMBLY INSTRUCTIONS

THESE DOCUMENTS ARE SUPPLIED WITH THE UNDERSTANDING THAT THEY WILL NOT BE DISCLOSED TO THIRD PARTIES WITHOUT WRITTEN CONSENT OF DIVERSIFIED WOODCRAFTS, INC. ANY REPRODUCTION IN PART OR WHOLE WITHOUT WRITTEN CONSENT IS SUBJECT TO LEGAL ACTION.

DRAWING NUMBER:	SCALE:	SHEET:	REVISION:
SSDT-30	NTS	4 OF 15	REV A

REVISION LEVEL	DESCRIPTION	DATE	NAME	ECN NO.
A	CREATED DRAWING	9/18/18	EMR	-

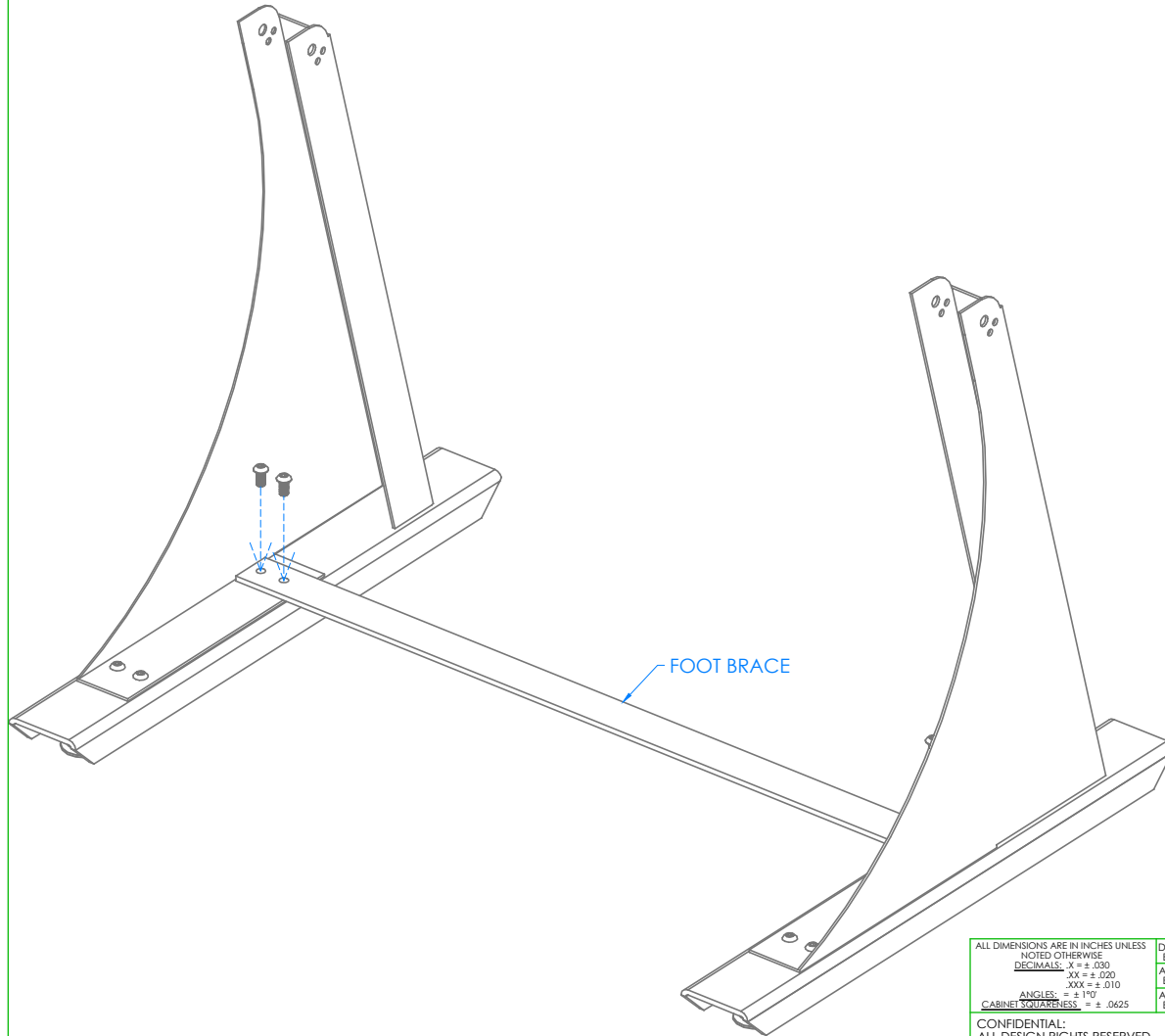

STEP 3:

- PLACE FOOT BRACE IN BETWEEN LEG ASSEMBLIES.
- ALIGN HOLES ON BRACE TO HOLES ON LEG ASSEMBLIES.
- ATTACH FOOT BRACE TO LEG ASSEMBLIES WITH HARDWARE REMOVED ON STEP 2.
- DO NOT TIGHTEN ALL THE WAY.

ALL DIMENSIONS ARE IN INCHES UNLESS NOTED OTHERWISE	DWN BY:	EMR	DATE DWN:	9/18/18
DECIMALS: $\times = \pm .000$	APR BY:		DATE APR:	
XX = $\pm .020$	APR BY:		DATE APR:	
XXX = $\pm .010$	APR BY:		DATE APR:	
ANGLES: = $\pm 1^{\circ}$	APR BY:		DATE APR:	
CABINET SQUARENESS: = $\pm .0625$	APR BY:		DATE APR:	

CONFIDENTIAL:  
 ALL DESIGN RIGHTS RESERVED  
 THE INFORMATION, DATA, DESIGN, AND DRAWINGS EMBODIED IN THIS DOCUMENT AND ALL REPRODUCTIONS THEREOF ARE THE EXCLUSIVE PROPERTY OF DIVERSIFIED WOODCRAFTS, INC.

THESE DOCUMENTS ARE SUPPLIED WITH THE UNDERSTANDING THAT THEY WILL NOT BE DISCLOSED TO THIRD PARTIES WITHOUT WRITTEN CONSENT OF DIVERSIFIED WOODCRAFTS, INC. ANY REPRODUCTION IN PART OR WHOLE WITHOUT WRITTEN CONSENT IS SUBJECT TO LEGAL ACTION.



300 South Krueger Street  
 Suring, WI 54174  
 diversifiedwoodcrafts.com

TITLE:  
 SIT-2-STAND DRAFTING TABLE  
 ASSEMBLY INSTRUCTIONS

REV.	DESCRIPTION	DATE	NAME	ECN NO.
A	CREATED DRAWING	9/18/18	EMR	-
REVISION LEVEL				

DRAWING NUMBER:	SSDT-30	SCALE:	NTS	SHEET:	5 OF 15	REVISION:	REV A
-----------------	---------	--------	-----	--------	---------	-----------	-------

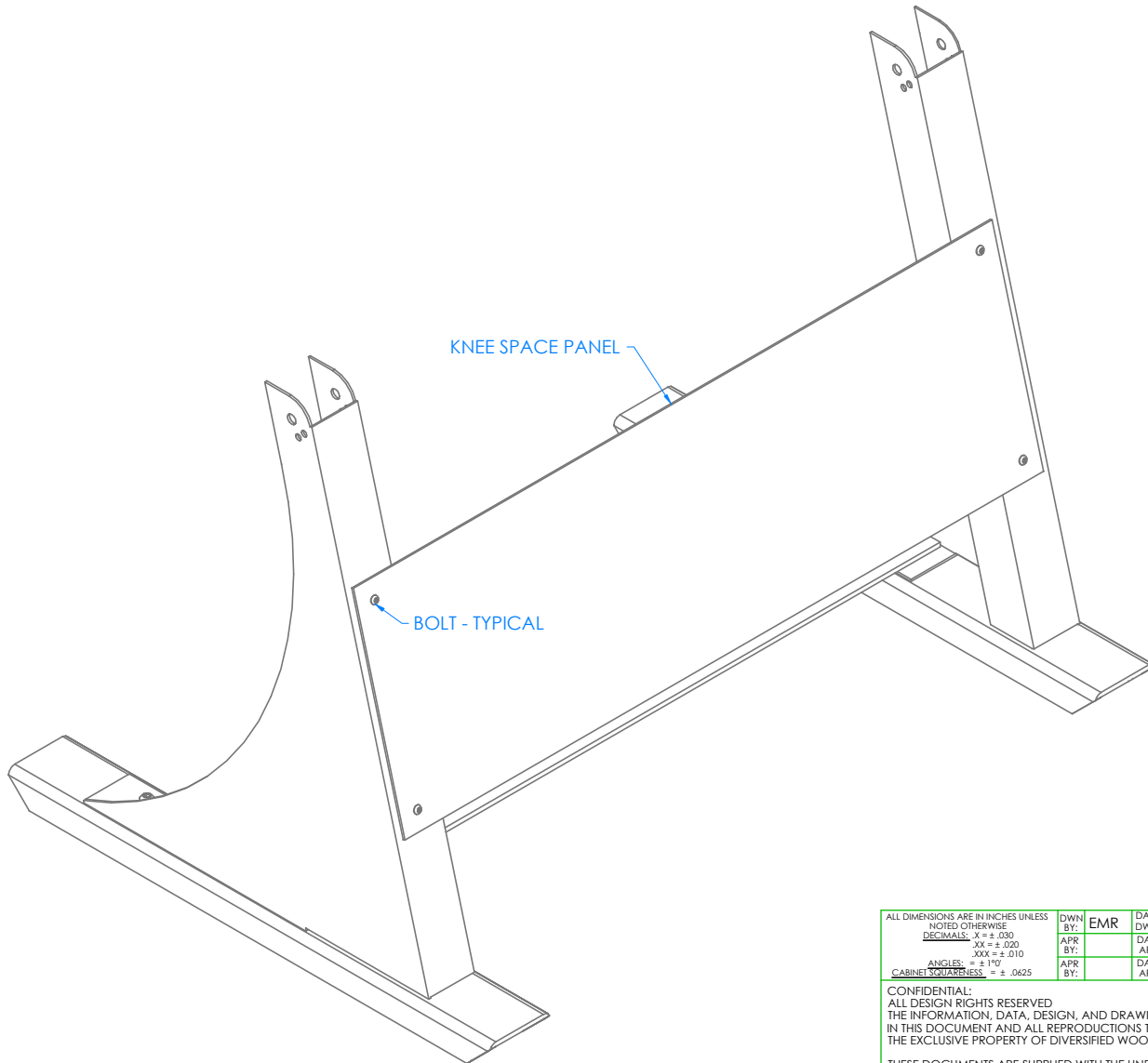

STEP 4:

- USING A  $\frac{3}{16}$ " ALLEN WRENCH AND  $\frac{1}{2}$ " WRENCH, ATTACH KNEE SPACE PANEL TO BACK OF LEGS WITH HARDWARE PROVIDED.
- DO NOT TIGHTEN ALL THE WAY.

ALL DIMENSIONS ARE IN INCHES UNLESS NOTED OTHERWISE	DWN BY:	EMR	DATE DWN:	9/18/18
DECIMALS: X = ± .030	APR BY:		DATE APR:	
XX = ± .020	APR BY:		DATE APR:	
XXX = ± .010	APR BY:		DATE APR:	
ANGLES: = ± 1°				
CABINET SQUARENESS: = ± .0625				

CONFIDENTIAL:  
 ALL DESIGN RIGHTS RESERVED  
 THE INFORMATION, DATA, DESIGN, AND DRAWINGS EMBODIED IN THIS DOCUMENT AND ALL REPRODUCTIONS THEREOF ARE THE EXCLUSIVE PROPERTY OF DIVERSIFIED WOODCRAFTS, INC.

THESE DOCUMENTS ARE SUPPLIED WITH THE UNDERSTANDING THAT THEY WILL NOT BE DISCLOSED TO THIRD PARTIES WITHOUT WRITTEN CONSENT OF DIVERSIFIED WOODCRAFTS, INC. ANY REPRODUCTION IN PART OR WHOLE WITHOUT WRITTEN CONSENT IS SUBJECT TO LEGAL ACTION.



300 South Krueger Street  
 Suring, WI 54174  
 diversifiedwoodcrafts.com

TITLE:  
 SIT-2-STAND DRAFTING TABLE  
 ASSEMBLY INSTRUCTIONS

REV.	DESCRIPTION	DATE	NAME	ECN NO.
A	CREATED DRAWING	9/18/18	EMR	-

REVISION LEVEL

DRAWING NUMBER:	SCALE:	SHEET:	REVISION:
SSDT-30	NTS	6 OF 15	REV A

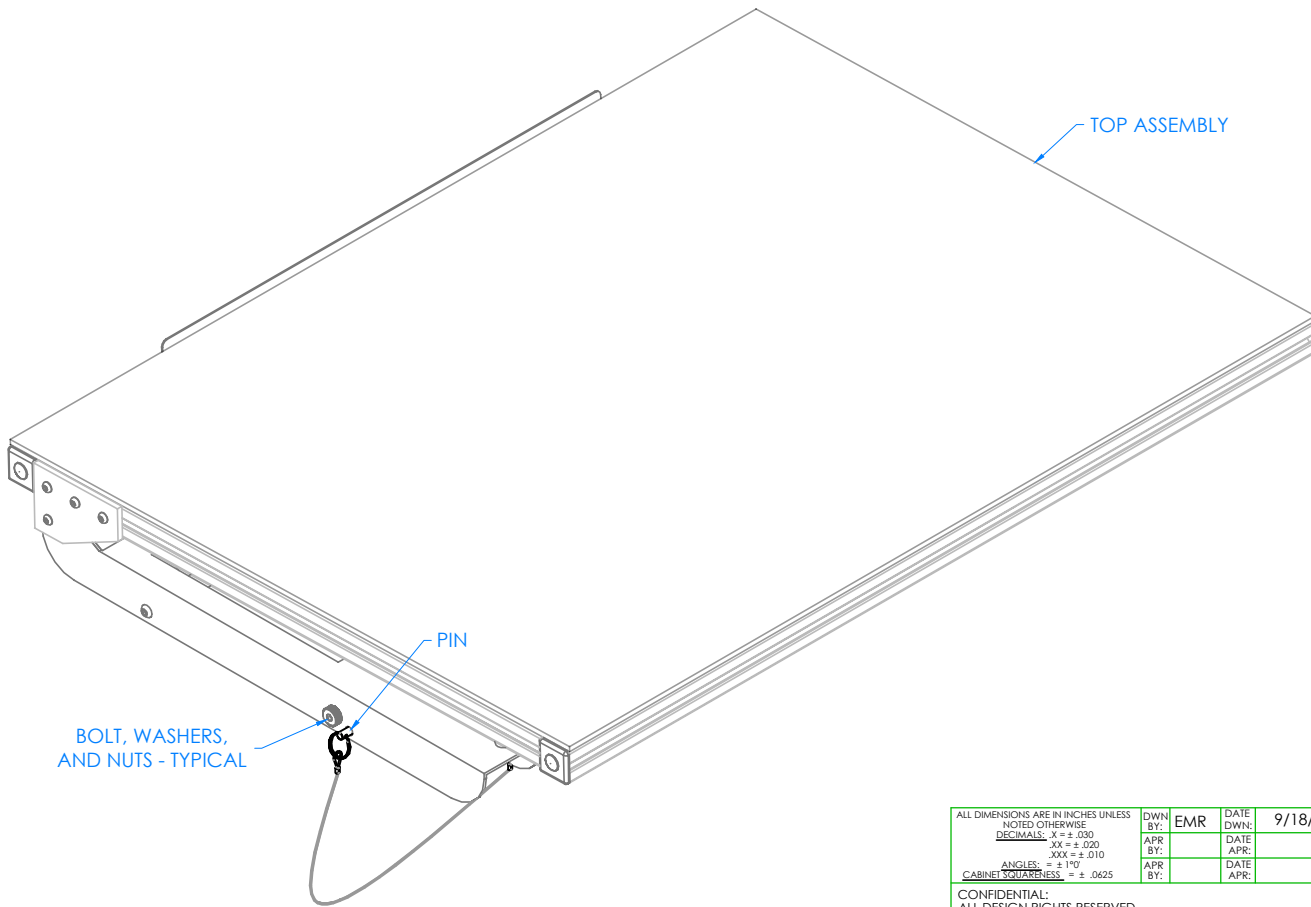

STEP 5:

- REMOVE BOLTS, WASHERS, AND NUTS FROM TOP ASSEMBLY.
- SET ASIDE.
- TAKE PIN OUT AND LET IT HANG.

ALL DIMENSIONS ARE IN INCHES UNLESS NOTED OTHERWISE	DWN BY:	EMR	DATE DWN:	9/18/18
DECIMALS: $\times = \pm .000$	APR BY:		DATE APR:	
XX = $\pm .020$	APR BY:		DATE APR:	
XXX = $\pm .010$	APR BY:		DATE APR:	
ANGLES: $= \pm 1^{\circ}0'$	APR BY:		DATE APR:	
CABINET SQUARENESS: $= \pm .0625$	APR BY:		DATE APR:	

CONFIDENTIAL:  
 ALL DESIGN RIGHTS RESERVED  
 THE INFORMATION, DATA, DESIGN, AND DRAWINGS EMBODIED IN THIS DOCUMENT AND ALL REPRODUCTIONS THEREOF ARE THE EXCLUSIVE PROPERTY OF DIVERSIFIED WOODCRAFTS, INC.

THESE DOCUMENTS ARE SUPPLIED WITH THE UNDERSTANDING THAT THEY WILL NOT BE DISCLOSED TO THIRD PARTIES WITHOUT WRITTEN CONSENT OF DIVERSIFIED WOODCRAFTS, INC. ANY REPRODUCTION IN PART OR WHOLE WITHOUT WRITTEN CONSENT IS SUBJECT TO LEGAL ACTION.



300 South Krueger Street  
 Suring, WI 54174  
 diversifiedwoodcrafts.com

TITLE:  
**SIT-2-STAND DRAFTING TABLE  
 ASSEMBLY INSTRUCTIONS**

REV.	DESCRIPTION	DATE	NAME	ECN NO.
A	CREATED DRAWING	9/18/18	EMR	-
REVISION LEVEL				

DRAWING NUMBER:	SCALE:	SHEET:	REVISION:
<b>SSDT-30</b>	NTS	7 OF 15	REV A

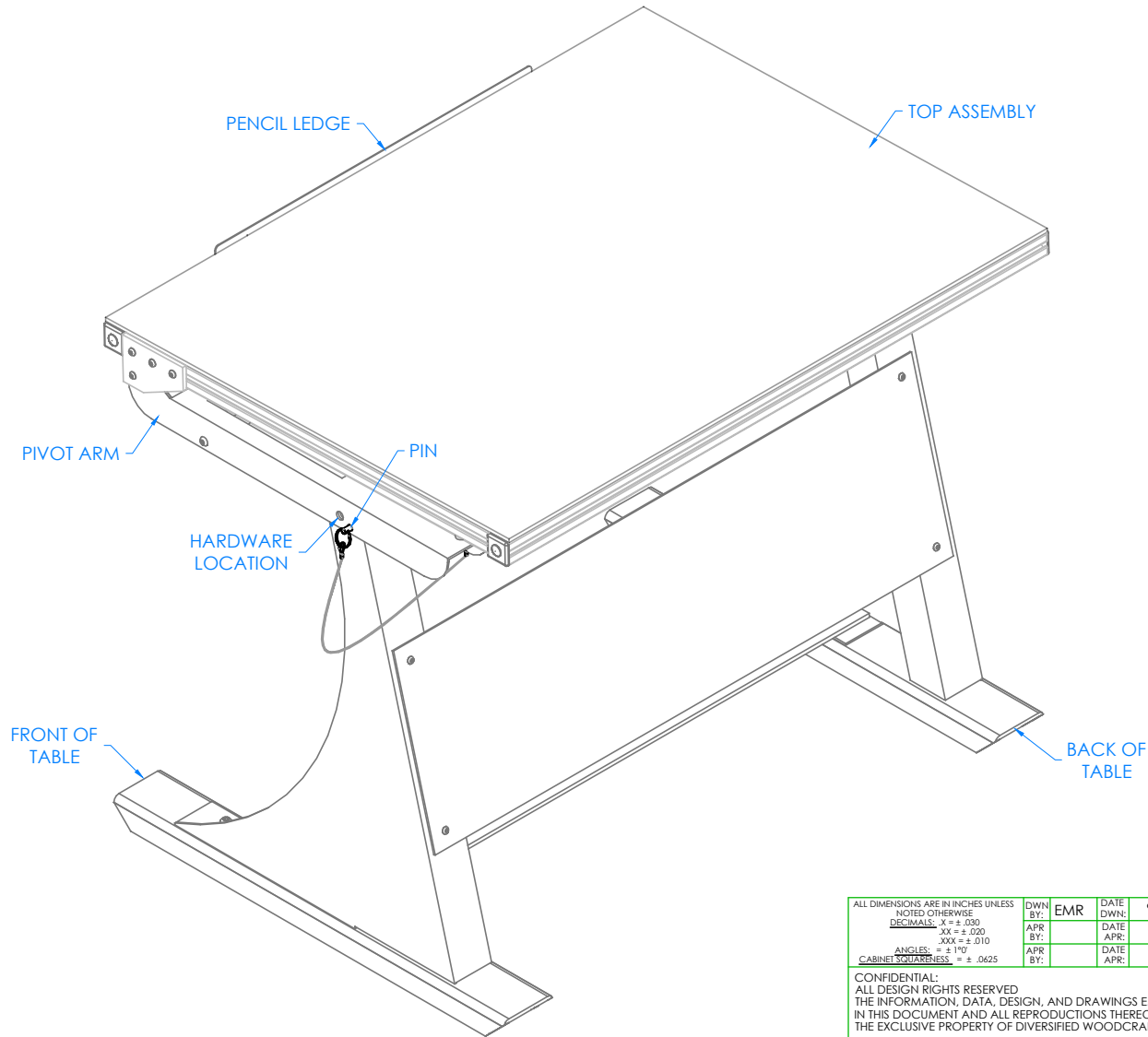

STEP 6:

- WITH HELP FROM ANOTHER PERSON, PLACE TOP ASSEMBLY ONTO LEG ASSEMBLIES.
- ALIGN HOLES ON THE PIVOT ARMS LOCATED ON EACH SIDE OF TOP ASSEMBLY TO THE HOLES WHERE HARDWARE WAS REMOVED ON STEP 5.
- PUSH PIN INTO LOCK LOCATION TO HOLD TOP ASSEMBLY IN PLACE.

ALL DIMENSIONS ARE IN INCHES UNLESS NOTED OTHERWISE		DWN BY:	EMR	DATE DWN:	9/18/18
DECIMALS: X = ± .000		APR BY:		DATE APR:	
XX = ± .020		APR BY:		DATE APR:	
XXX = ± .010		APR BY:		DATE APR:	
ANGLES: = ± 1°		APR BY:		DATE APR:	
CABINET SQUARENESS: = ± .0625		APR BY:		DATE APR:	

CONFIDENTIAL:  
 ALL DESIGN RIGHTS RESERVED  
 THE INFORMATION, DATA, DESIGN, AND DRAWINGS EMBODIED IN THIS DOCUMENT AND ALL REPRODUCTIONS THEREOF ARE THE EXCLUSIVE PROPERTY OF DIVERSIFIED WOODCRAFTS, INC.

THESE DOCUMENTS ARE SUPPLIED WITH THE UNDERSTANDING THAT THEY WILL NOT BE DISCLOSED TO THIRD PARTIES WITHOUT WRITTEN CONSENT OF DIVERSIFIED WOODCRAFTS, INC. ANY REPRODUCTION IN PART OR WHOLE WITHOUT WRITTEN CONSENT IS SUBJECT TO LEGAL ACTION.



300 South Krueger Street  
 Suring, WI 54174  
 diversifiedwoodcrafts.com

TITLE:  
**SIT-2-STAND DRAFTING TABLE  
 ASSEMBLY INSTRUCTIONS**

REV.	DESCRIPTION	DATE	NAME	ECN NO.
A	CREATED DRAWING	9/18/18	EMR	-
REVISION LEVEL				

DRAWING NUMBER:	SCALE:	SHEET:	REVISION:
<b>SSDT-30</b>	NTS	8 OF 15	REV A



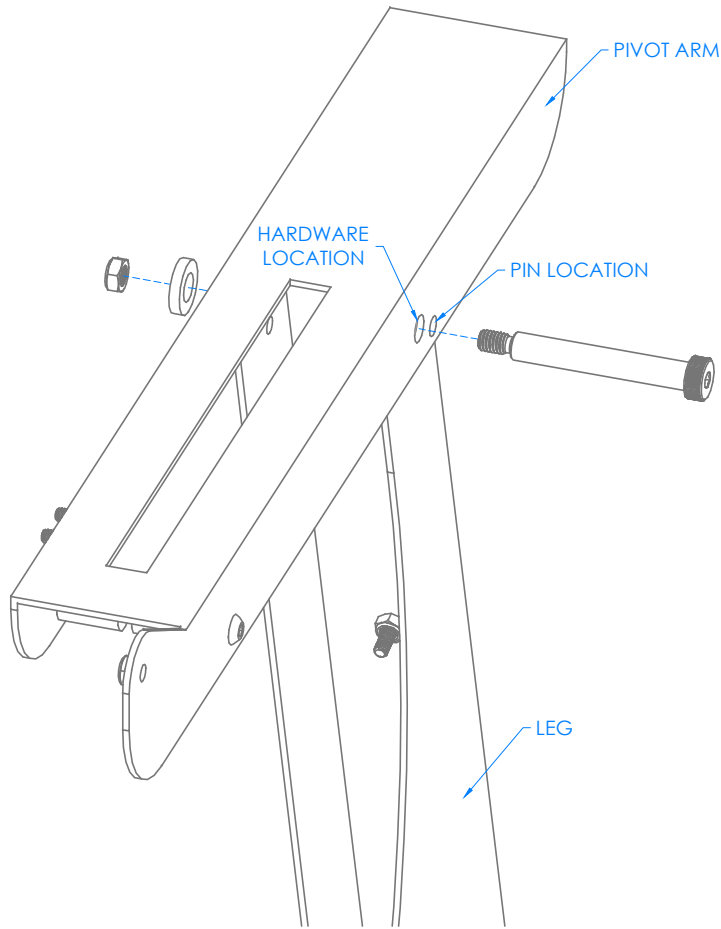

TOP ASSEMBLY REMOVED TO SHOW CLARITY

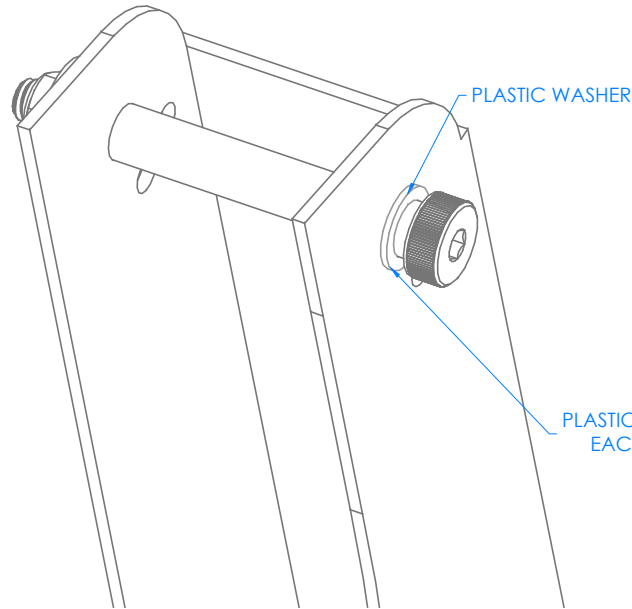

TOP ASSEMBLY AND PIVOT ARM REMOVED TO SHOW CLARITY

STEP 7:

- USING A 1/4" ALLEN WRENCH AND 3/16" WRENCH, INSERT BOLTS, WASHERS, AND NUTS INTO HARDWARE LOCATION LOCATED ON TOP OF LEG.
- REPEAT ON BOTH LEGS.
- MAKE SURE ALL NUTS ARE TIGHT.

**\*\*NOTE\*\***  
 PLASTIC WASHERS MUST BE LOCATED IN BETWEEN EACH PIECE OF METAL TO AVOID FRICTION (PIVOT ARM AND LEG ASSEMBLY)

ALL DIMENSIONS ARE IN INCHES UNLESS NOTED OTHERWISE		DWN BY:	EMR	DATE DWN:	9/18/18
DECIMALS: X = ± .000		APR BY:		DATE APR:	
XX = ± .020		APR BY:		DATE APR:	
XXX = ± .010		APR BY:		DATE APR:	
ANGLES: = ± 1°		APR BY:		DATE APR:	
CABINET SQUARENESS: = ± .0625		APR BY:		DATE APR:	

CONFIDENTIAL:  
 ALL DESIGN RIGHTS RESERVED  
 THE INFORMATION, DATA, DESIGN, AND DRAWINGS EMBODIED IN THIS DOCUMENT AND ALL REPRODUCTIONS THEREOF ARE THE EXCLUSIVE PROPERTY OF DIVERSIFIED WOODCRAFTS, INC.

THESE DOCUMENTS ARE SUPPLIED WITH THE UNDERSTANDING THAT THEY WILL NOT BE DISCLOSED TO THIRD PARTIES WITHOUT WRITTEN CONSENT OF DIVERSIFIED WOODCRAFTS, INC. ANY REPRODUCTION IN PART OR WHOLE WITHOUT WRITTEN CONSENT IS SUBJECT TO LEGAL ACTION.



300 South Krueger Street  
 Suring, WI 54174  
 diversifiedwoodcrafts.com

TITLE:  
 SIT-2-STAND DRAFTING TABLE  
 ASSEMBLY INSTRUCTIONS

REV.	DESCRIPTION	DATE	NAME	ECN NO.
A	CREATED DRAWING	9/18/18	EMR	-

REVISION LEVEL

DRAWING NUMBER:	SSDT-30	SCALE:	NTS	SHEET:	9 OF 15	REVISION:	REV A
-----------------	---------	--------	-----	--------	---------	-----------	-------



STEP 8:

- GO BACK TO STEP 3 AND 4 AND TIGHTEN UP ALL HARDWARE FOR FOOT BRACE AND KNEE SPACE PANEL.
- SOME ADJUSTMENTS MAY BE REQUIRED.
- ADJUST LEG LEVELERS TO LEVEL TABLE.
- SET TABLE IN DESIRED LOCATION.
- SEE FOLLOWING STEPS ON HOW TO ADJUST TOP FROM SITTING TO STANDING POSITION.

COMPLETE UNIT SHOWN

ALL DIMENSIONS ARE IN INCHES UNLESS NOTED OTHERWISE			
DECIMALS:	X = ± .000	DWN BY:	EMR
	XX = ± .020	DATE DWN:	9/18/18
	XXX = ± .010	APR BY:	
ANGLES:	= ± 1°0'	DATE APR:	
CABINET SQUARENESS:	= ± .0625	APR BY:	

CONFIDENTIAL:  
 ALL DESIGN RIGHTS RESERVED  
 THE INFORMATION, DATA, DESIGN, AND DRAWINGS EMBODIED IN THIS DOCUMENT AND ALL REPRODUCTIONS THEREOF ARE THE EXCLUSIVE PROPERTY OF DIVERSIFIED WOODCRAFTS, INC.

THESE DOCUMENTS ARE SUPPLIED WITH THE UNDERSTANDING THAT THEY WILL NOT BE DISCLOSED TO THIRD PARTIES WITHOUT WRITTEN CONSENT OF DIVERSIFIED WOODCRAFTS, INC. ANY REPRODUCTION IN PART OR WHOLE WITHOUT WRITTEN CONSENT IS SUBJECT TO LEGAL ACTION.



300 South Krueger Street  
 Suring, WI 54174  
 diversifiedwoodcrafts.com

TITLE:  
 SIT-2-STAND DRAFTING TABLE  
 ASSEMBLY INSTRUCTIONS

REV.	DESCRIPTION	DATE	NAME	ECN NO.
A	CREATED DRAWING	9/18/18	EMR	-
REVISION LEVEL				

DRAWING NUMBER:	SSDT-30	SCALE:	NTS	SHEET:	10 OF 15	REVISION:	REV A
-----------------	---------	--------	-----	--------	----------	-----------	-------

# SITTING POSITION

RAISE TOP UP TO DESIRED ANGLE



FRAME AT SITTING POSITION WITH TOP UP SHOWN

STEP 9:

- TO RAISE TOP, GRAB TOP FRAME AND EXTEND TO DESIRED ANGLE.

NOTE:

1.

ALL DIMENSIONS ARE IN INCHES UNLESS NOTED OTHERWISE	DWN BY:	EMR	DATE DWN:	9/18/18
DECIMALS: X = ± .000	APR BY:		DATE APR:	
XX = ± .020	APR BY:		DATE APR:	
XXX = ± .010	APR BY:		DATE APR:	
ANGLES: = ± 1°0'	APR BY:		DATE APR:	
CABINET SQUARENESS: = ± .0625	APR BY:		DATE APR:	

CONFIDENTIAL:  
ALL DESIGN RIGHTS RESERVED  
THE INFORMATION, DATA, DESIGN, AND DRAWINGS EMBODIED IN THIS DOCUMENT AND ALL REPRODUCTIONS THEREOF ARE THE EXCLUSIVE PROPERTY OF DIVERSIFIED WOODCRAFTS, INC.

THESE DOCUMENTS ARE SUPPLIED WITH THE UNDERSTANDING THAT THEY WILL NOT BE DISCLOSED TO THIRD PARTIES WITHOUT WRITTEN CONSENT OF DIVERSIFIED WOODCRAFTS, INC. ANY REPRODUCTION IN PART OR WHOLE WITHOUT WRITTEN CONSENT IS SUBJECT TO LEGAL ACTION.



300 South Krueger Street  
Suring, WI 54174  
diversifiedwoodcrafts.com

TITLE:  
SIT-2-STAND DRAFTING TABLE  
ASSEMBLY INSTRUCTIONS

REV.	DESCRIPTION	DATE	NAME	ECN NO.
A	CREATED DRAWING	9/18/18	EMR	-
REVISION LEVEL				

DRAWING NUMBER:	SCALE:	SHEET:	REVISION:
SSTD-30	NTS	11 OF 15	REV A

# SITTING POSITION



FRAME AT SITTING POSITION WITH TOP DOWN SHOWN

STEP 10:

- TO LOWER TOP, EXTEND TOP FRAME UNTIL YOU RELEASE RATCHET.
- TOP WILL SLOWLY LOWER ONTO METAL FRAME.

NOTE:

1.

ALL DIMENSIONS ARE IN INCHES UNLESS NOTED OTHERWISE	DWN BY:	EMR	DATE DWN:	9/18/18
DECIMALS: X = ± .000	APR BY:		DATE APR:	
XX = ± .020	APR BY:		DATE APR:	
XXX = ± .010	APR BY:		DATE APR:	
ANGLES: = ± 1°0'	APR BY:		DATE APR:	
CABINET SQUARENESS: = ± .0625	APR BY:		DATE APR:	

CONFIDENTIAL:  
ALL DESIGN RIGHTS RESERVED  
THE INFORMATION, DATA, DESIGN, AND DRAWINGS EMBODIED IN THIS DOCUMENT AND ALL REPRODUCTIONS THEREOF ARE THE EXCLUSIVE PROPERTY OF DIVERSIFIED WOODCRAFTS, INC.

THESE DOCUMENTS ARE SUPPLIED WITH THE UNDERSTANDING THAT THEY WILL NOT BE DISCLOSED TO THIRD PARTIES WITHOUT WRITTEN CONSENT OF DIVERSIFIED WOODCRAFTS, INC. ANY REPRODUCTION IN PART OR WHOLE WITHOUT WRITTEN CONSENT IS SUBJECT TO LEGAL ACTION.



300 South Krueger Street  
Suring, WI 54174  
diversifiedwoodcrafts.com

TITLE:  
SIT-2-STAND DRAFTING TABLE  
ASSEMBLY INSTRUCTIONS

REV.	DESCRIPTION	DATE	NAME	ECN NO.
A	CREATED DRAWING	9/18/18	EMR	-

REVISION LEVEL

DRAWING NUMBER:	SCALE:	SHEET:	REVISION:
SSDT-30	NTS	12 OF 15	REV A

# STANDING POSITION



FRAME AT SITTING POSITION SHOWN

STEP 11:

- TAKE PIN OUT OF LOCK LOCATION LOCATED ON BOTH SIDES OF FRAME.
- LET PIN HANG FROM BOLT.

NOTE:

1.

ALL DIMENSIONS ARE IN INCHES UNLESS NOTED OTHERWISE DECIMALS: X = ± .000 XX = ± .020 XXX = ± .010 ANGLES: = ± 1°0' CABINET SQUARENESS: = ± .0625	DWN BY: EMR	DATE DWN: 9/18/18
	APR BY:	DATE APR:
	APR BY:	DATE APR:

CONFIDENTIAL:  
ALL DESIGN RIGHTS RESERVED  
THE INFORMATION, DATA, DESIGN, AND DRAWINGS EMBODIED IN THIS DOCUMENT AND ALL REPRODUCTIONS THEREOF ARE THE EXCLUSIVE PROPERTY OF DIVERSIFIED WOODCRAFTS, INC.

THESE DOCUMENTS ARE SUPPLIED WITH THE UNDERSTANDING THAT THEY WILL NOT BE DISCLOSED TO THIRD PARTIES WITHOUT WRITTEN CONSENT OF DIVERSIFIED WOODCRAFTS, INC. ANY REPRODUCTION IN PART OR WHOLE WITHOUT WRITTEN CONSENT IS SUBJECT TO LEGAL ACTION.



300 South Krueger Street  
Suring, WI 54174  
diversifiedwoodcrafts.com

TITLE:  
**SIT-2-STAND DRAFTING TABLE  
ASSEMBLY INSTRUCTIONS**

REV.	DESCRIPTION	DATE	NAME	ECN NO.
A	CREATED DRAWING	9/18/18	EMR	-
REVISION LEVEL				

DRAWING NUMBER: <b>SSDT-30</b>	SCALE: NTS	SHEET: 13 OF 15	REVISION: REV A
-----------------------------------	---------------	--------------------	--------------------

# STANDING POSITION

**\*\*NOTE\*\***  
GLASS TOP WILL STILL BE ON METAL FRAME AT THIS TIME. DO NOT ADJUST GLASS UNTIL FRAME IS IN STANDING POSITION AND LOCKED INTO PLACE



INSERT PIN BACK INTO LOCK

METAL FRAME TIPPED BACK FOR STANDING POSITION

FRAME AT STANDING POSITION SHOWN TOP ONLY OPENED TO SHOW CLARITY

STEP 12:

- TIP METAL FRAME BACK TO FIRST PIVOT.
- SLIDE PIN BACK INTO LOCK.
- REPEAT ON OTHER SIDE.

NOTE:

1.

ALL DIMENSIONS ARE IN INCHES UNLESS NOTED OTHERWISE	DWN BY:	EMR	DATE DWN:	9/18/18
DECIMALS: X = ± .000	APR BY:		DATE APR:	
XX = ± .020	APR BY:		DATE APR:	
XXX = ± .010	APR BY:		DATE APR:	
ANGLES: = ± 1°0'	APR BY:		DATE APR:	
CABINET SQUARENESS: = ± .0625	APR BY:		DATE APR:	

CONFIDENTIAL:  
ALL DESIGN RIGHTS RESERVED  
THE INFORMATION, DATA, DESIGN, AND DRAWINGS EMBODIED IN THIS DOCUMENT AND ALL REPRODUCTIONS THEREOF ARE THE EXCLUSIVE PROPERTY OF DIVERSIFIED WOODCRAFTS, INC.

THESE DOCUMENTS ARE SUPPLIED WITH THE UNDERSTANDING THAT THEY WILL NOT BE DISCLOSED TO THIRD PARTIES WITHOUT WRITTEN CONSENT OF DIVERSIFIED WOODCRAFTS, INC. ANY REPRODUCTION IN PART OR WHOLE WITHOUT WRITTEN CONSENT IS SUBJECT TO LEGAL ACTION.



300 South Krueger Street  
Suring, WI 54174  
diversifiedwoodcrafts.com

TITLE:  
SIT-2-STAND DRAFTING TABLE  
ASSEMBLY INSTRUCTIONS

REV.	DESCRIPTION	DATE	NAME	ECN NO.
A	CREATED DRAWING	9/18/18	EMR	-

REVISION LEVEL

DRAWING NUMBER:	SCALE:	SHEET:	REVISION:
SSTD-30	NTS	14 OF 15	REV A

# STANDING POSITION

RAISE TOP UP TO DESIRED ANGLE



FRAME AT STANDING POSITION WITH TOP UP

STEP 13:

- TO RAISE TOP, GRAB TOP FRAME AND EXTEND TO DESIRED ANGLE.
- TO LOWER TOP, EXTEND TOP FRAME UNTIL YOU RELEASE RATCHET.
- TOP WILL SLOWLY LOWER ONTO METAL FRAME.

NOTE:

1.

ALL DIMENSIONS ARE IN INCHES UNLESS NOTED OTHERWISE	DWN BY:	EMR	DATE DWN:	9/18/18
DECIMALS: X = ± .000	APR BY:		DATE APR:	
XX = ± .020	APR BY:		DATE APR:	
XXX = ± .010	APR BY:		DATE APR:	
ANGLES: = ± 1°0'	APR BY:		DATE APR:	
CABINET SQUARENESS: = ± .0625	APR BY:		DATE APR:	

CONFIDENTIAL:  
ALL DESIGN RIGHTS RESERVED  
THE INFORMATION, DATA, DESIGN, AND DRAWINGS EMBODIED IN THIS DOCUMENT AND ALL REPRODUCTIONS THEREOF ARE THE EXCLUSIVE PROPERTY OF DIVERSIFIED WOODCRAFTS, INC.

THESE DOCUMENTS ARE SUPPLIED WITH THE UNDERSTANDING THAT THEY WILL NOT BE DISCLOSED TO THIRD PARTIES WITHOUT WRITTEN CONSENT OF DIVERSIFIED WOODCRAFTS, INC. ANY REPRODUCTION IN PART OR WHOLE WITHOUT WRITTEN CONSENT IS SUBJECT TO LEGAL ACTION.



300 South Krueger Street  
Suring, WI 54174  
diversifiedwoodcrafts.com

TITLE:  
SIT-2-STAND DRAFTING TABLE  
ASSEMBLY INSTRUCTIONS

REV.	DESCRIPTION	DATE	NAME	ECN NO.
A	CREATED DRAWING	9/18/18	EMR	-

REVISION LEVEL

DRAWING NUMBER:	SCALE:	SHEET:	REVISION:
SSTD-30	NTS	15 OF 15	REV A