

ROBOT TOTE TRAY CABINET

VXT-3624, XT-3624, VXT-5024, & XT-5024
ASSEMBLY INSTRUCTIONS

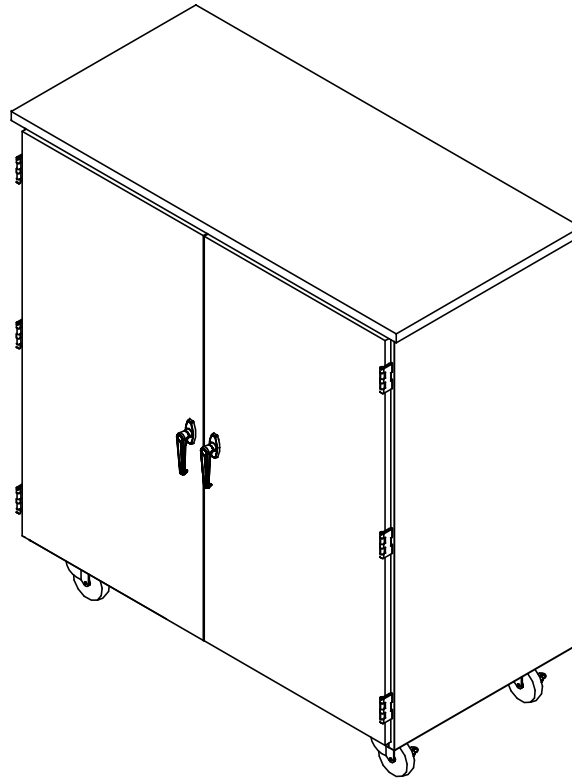

NOTE:

1. MODEL VIEWS MAY NOT REPRESENT EXACT MODEL PURCHASED

ALL DIMENSIONS ARE IN INCHES UNLESS NOTED OTHERWISE	DWN BY:	EMR	DATE DWN:	11/15/16
DECIMALS: $\frac{X}{1000}$	APR BY:		DATE APR:	
$\frac{XX}{100} = \pm .020$	APR BY:		DATE APR:	
$\frac{XXX}{1000} = \pm .010$	APR BY:		DATE APR:	
ANGLES: $\pm 1^{\circ}0'$				
CABINET SQUARENESS: $\pm .0625$				

CONFIDENTIAL:
ALL DESIGN RIGHTS RESERVED
THE INFORMATION, DATA, DESIGN, AND DRAWINGS EMBODIED IN THIS DOCUMENT AND ALL REPRODUCTIONS THEREOF ARE THE EXCLUSIVE PROPERTY OF DIVERSIFIED WOODCRAFTS, INC.

THESE DOCUMENTS ARE SUPPLIED WITH THE UNDERSTANDING THAT THEY WILL NOT BE DISCLOSED TO THIRD PARTIES WITHOUT WRITTEN CONSENT OF DIVERSIFIED WOODCRAFTS, INC. ANY REPRODUCTION IN PART OR WHOLE WITHOUT WRITTEN CONSENT IS SUBJECT TO LEGAL ACTION.



300 South Krueger Street
Suring, WI 54174
diversifiedwoodcrafts.com

TITLE:
**ROBOT TOTE TRAY CABINET
ASSEMBLY INSTRUCTIONS**

REV.	DESCRIPTION	DATE	NAME	ECN NO.
A	CREATED DRAWING	11/15/16	EMR	-
REVISION LEVEL				

DRAWING NUMBER:	SCALE:	SHEET:	REVISION:
VXT & XT-3624, VXT & XT-5024	NTS	1 OF 5	REV A

TOOLS REQUIRED

1/2" WRENCH

ADJUSTABLE PLIERS

ASSEMBLY COMPONENTS

ITEMS INCLUDED	PART #	PART DESCRIPTION	QTY
CASTERS	100081	CASTER,4IN SWIVEL TOP PLATE, W/BRAKE	4
CASTER HARDWARE KIT	235317	CASTER,ASSY,HDWRE,16-SCREWS, 16-NUTS	1
SHELF CLIPS	100027	SHELF CLIPS,PLASTIC,5MM PIN	VARIES

NOTE:

1.

ALL DIMENSIONS ARE IN INCHES UNLESS NOTED OTHERWISE DECIMALS: X = ± .000 XX = ± .020 XXX = ± .010 ANGLES: = ± 1° CABINET SQUARENESS: = ± .0625	DWN BY: EMR	DATE DWN: 11/15/16
	APR BY:	DATE APR:
	APR BY:	DATE APR:

CONFIDENTIAL:
ALL DESIGN RIGHTS RESERVED
THE INFORMATION, DATA, DESIGN, AND DRAWINGS EMBODIED IN THIS DOCUMENT AND ALL REPRODUCTIONS THEREOF ARE THE EXCLUSIVE PROPERTY OF DIVERSIFIED WOODCRAFTS, INC.

THESE DOCUMENTS ARE SUPPLIED WITH THE UNDERSTANDING THAT THEY WILL NOT BE DISCLOSED TO THIRD PARTIES WITHOUT WRITTEN CONSENT OF DIVERSIFIED WOODCRAFTS, INC. ANY REPRODUCTION IN PART OR WHOLE WITHOUT WRITTEN CONSENT IS SUBJECT TO LEGAL ACTION.



300 South Krueger Street
Suring, WI 54174
diversifiedwoodcrafts.com

TITLE:
ROBOT TOTE TRAY CABINET
TOOLS AND ASSEMBLY COMPONENTS

REV.	DESCRIPTION	DATE	NAME	ECN NO.
A	CREATED DRAWING	11/15/16	EMR	-

REVISION LEVEL

DRAWING NUMBER: VXT & XT-3624, VXT & XT-5024	SCALE: NTS	SHEET: 2 OF 5	REVISION: REV A
---	---------------	------------------	--------------------

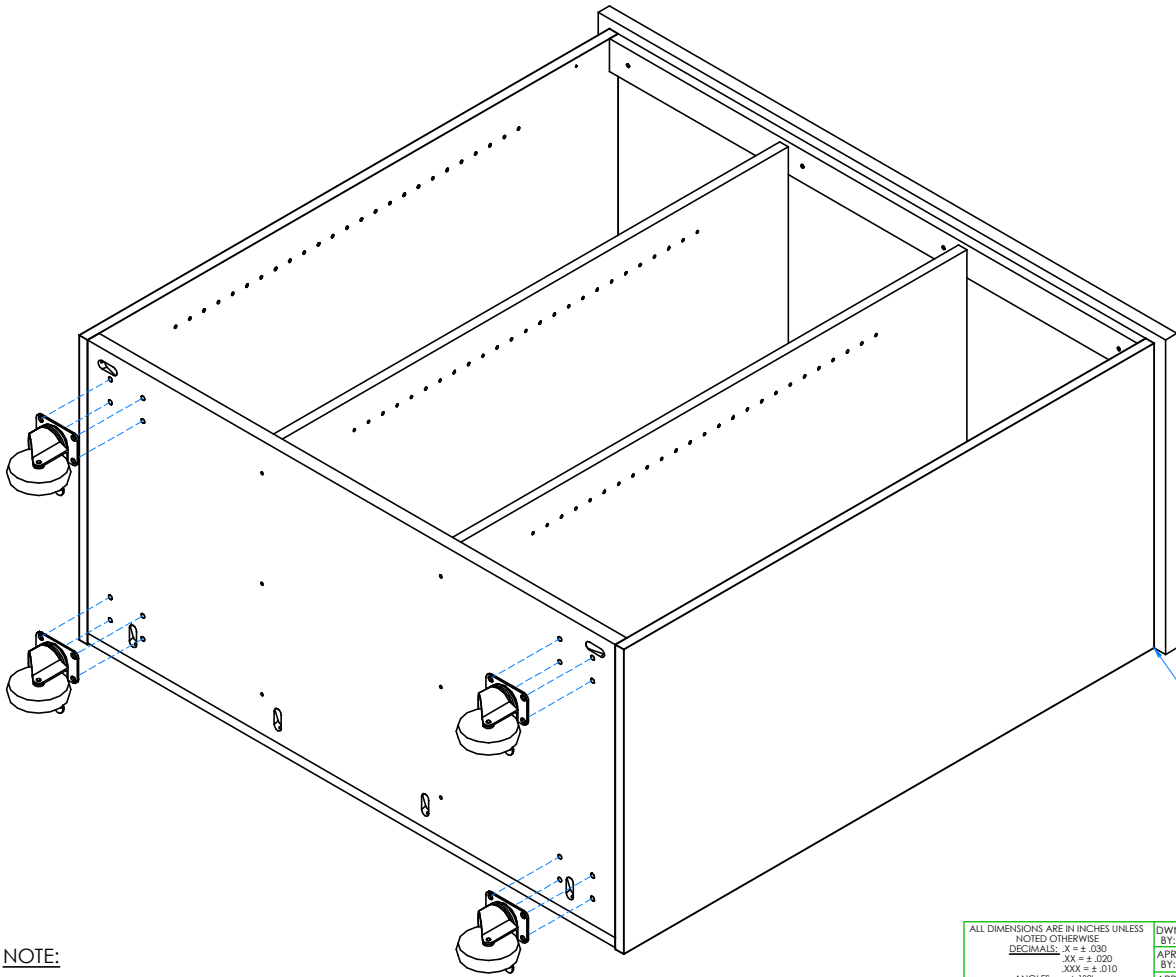

STEP 1:

- WITH HELP FROM ANOTHER PERSON, LAY CABINET ON ITS BACK.
- ATTACH CASTERS FROM INSIDE THE CABINET WITH HARDWARE PROVIDED.

****NOTE****
BE SURE CABINET IS ON
A CLEAN SURFACE TO
PREVENT DAMAGE

NOTE:

1.

DOORS AND HARDWARE REMOVED TO
SHOW CLARITY

A	CREATED DRAWING	11/15/16	EMR	-
REV.	DESCRIPTION	DATE	NAME	ECN NO.

REVISION LEVEL

ALL DIMENSIONS ARE IN INCHES UNLESS NOTED OTHERWISE	DWN BY:	EMR	DATE DWN:	11/15/16
DECIMALS: $X = \pm .000$	APR BY:		DATE APR:	
$XX = \pm .020$	APR BY:		DATE APR:	
$XXX = \pm .010$	APR BY:		DATE APR:	
ANGLES: $= \pm 1^{\circ}0'$	APR BY:		DATE APR:	
CABINET SQUARENESS: $= \pm .0625$	APR BY:		DATE APR:	

CONFIDENTIAL:
ALL DESIGN RIGHTS RESERVED
THE INFORMATION, DATA, DESIGN, AND DRAWINGS EMBODIED IN THIS DOCUMENT AND ALL REPRODUCTIONS THEREOF ARE THE EXCLUSIVE PROPERTY OF DIVERSIFIED WOODCRAFTS, INC.

THESE DOCUMENTS ARE SUPPLIED WITH THE UNDERSTANDING THAT THEY WILL NOT BE DISCLOSED TO THIRD PARTIES WITHOUT WRITTEN CONSENT OF DIVERSIFIED WOODCRAFTS, INC. ANY REPRODUCTION IN PART OR WHOLE WITHOUT WRITTEN CONSENT IS SUBJECT TO LEGAL ACTION.



300 South Krueger Street
Suring, WI 54174
diversifiedwoodcrafts.com

TITLE:
ROBOT TOTE TRAY CABINET
ASSEMBLY INSTRUCTIONS

DRAWING NUMBER:	SCALE:	SHEET:	REVISION:
VXT & XT-3624, VXT & XT-5024	NTS	3 OF 5	REV A

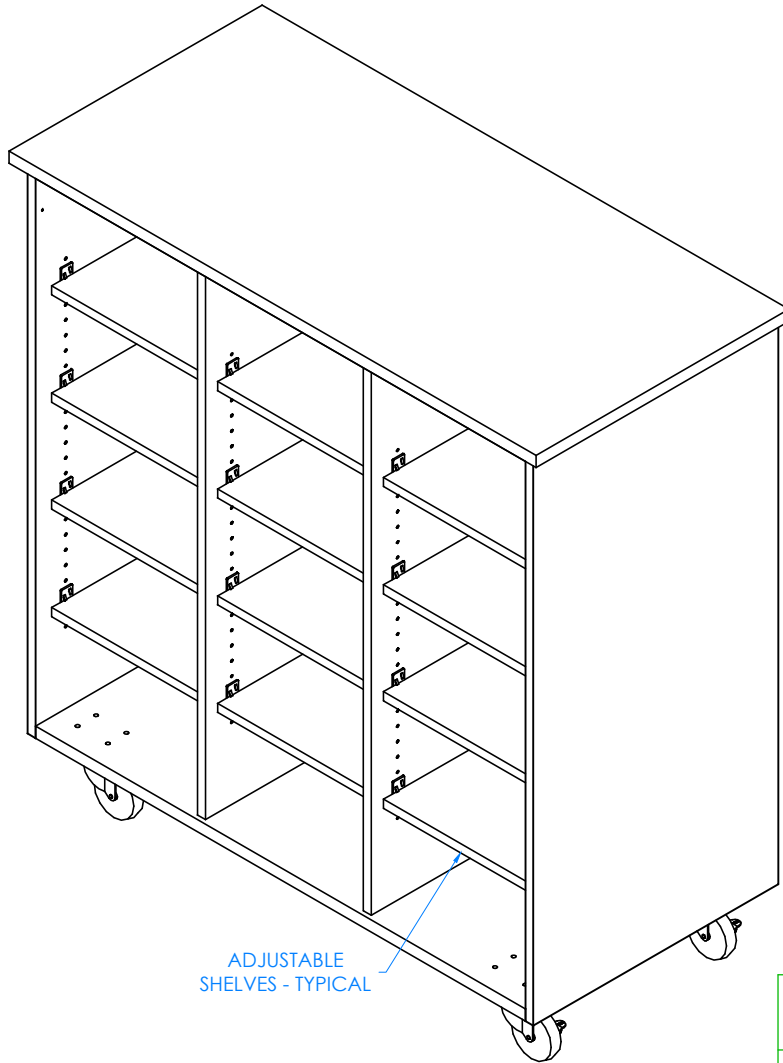

ADJUSTABLE SHELVES - TYPICAL

DOORS AND HARDWARE REMOVED TO SHOW CLARITY

NOTE:

1.

STEP 2:

- TIP CABINET UP.
- INSERT SHELF CLIPS IN DESIRED LOCATION.
- PLACE SHELVES ON CLIPS, MAKING SURE THEY ARE LEVEL.
- PLACE TOTE TRAYS ON ADJUSTABLE SHELVES (NOT SHOWN).

ALL DIMENSIONS ARE IN INCHES UNLESS NOTED OTHERWISE	DWN BY:	EMR	DATE DWN:	11/15/16
DECIMALS: X = ± .000	APR BY:		DATE APR:	
XX = ± .020	APR BY:		DATE APR:	
XXX = ± .010	APR BY:		DATE APR:	
ANGLES: = ± 1°	APR BY:		DATE APR:	
CABINET SQUARENESS: = ± .0625	APR BY:		DATE APR:	

CONFIDENTIAL:
ALL DESIGN RIGHTS RESERVED
THE INFORMATION, DATA, DESIGN, AND DRAWINGS EMBODIED IN THIS DOCUMENT AND ALL REPRODUCTIONS THEREOF ARE THE EXCLUSIVE PROPERTY OF DIVERSIFIED WOODCRAFTS, INC.

THESE DOCUMENTS ARE SUPPLIED WITH THE UNDERSTANDING THAT THEY WILL NOT BE DISCLOSED TO THIRD PARTIES WITHOUT WRITTEN CONSENT OF DIVERSIFIED WOODCRAFTS, INC. ANY REPRODUCTION IN PART OR WHOLE WITHOUT WRITTEN CONSENT IS SUBJECT TO LEGAL ACTION.



300 South Krueger Street
Suring, WI 54174
diversifiedwoodcrafts.com

TITLE:
**ROBOT TOTE TRAY CABINET
ASSEMBLY INSTRUCTIONS**

REV.	DESCRIPTION	DATE	NAME	ECN NO.
A	CREATED DRAWING	11/15/16	EMR	-
REVISION LEVEL				

DRAWING NUMBER:	SCALE:	SHEET:	REVISION:
VXT & XT-3624, VXT & XT-5024	NTS	4 OF 5	REV A

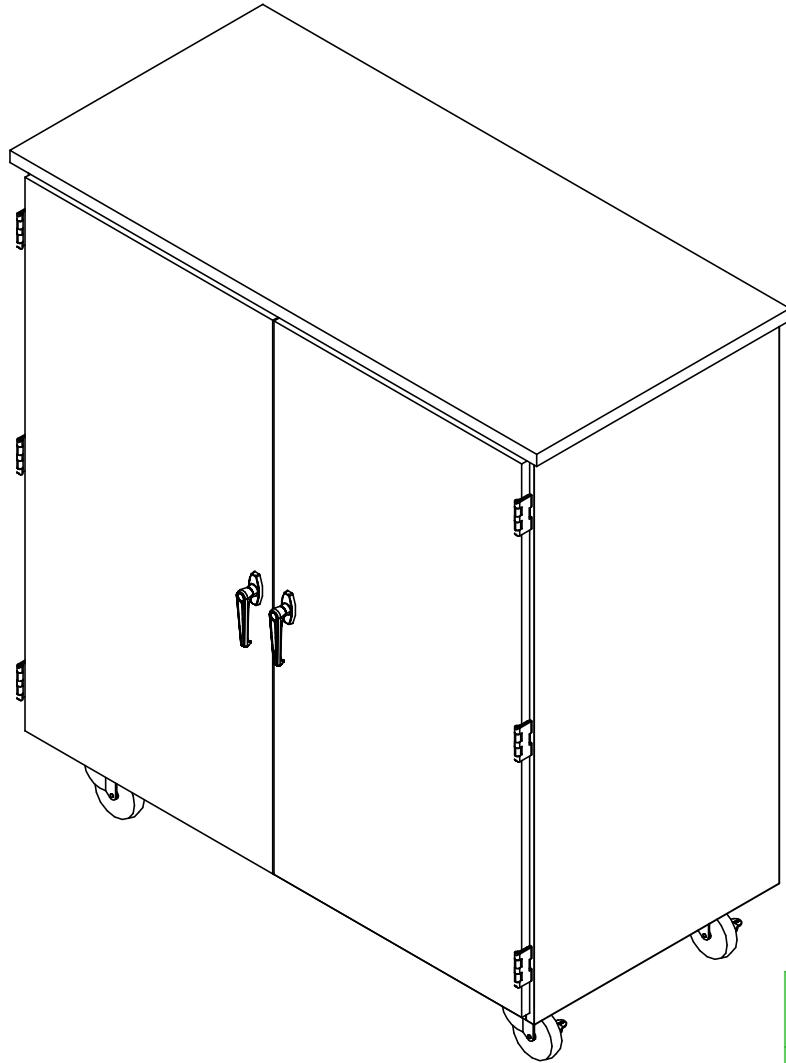

NOTE:

1.

COMPLETE UNIT SHOWN

REV.	DESCRIPTION	DATE	NAME	ECN NO.
A	CREATED DRAWING	11/15/16	EMR	-
REVISION LEVEL				

ALL DIMENSIONS ARE IN INCHES UNLESS NOTED OTHERWISE	DWN BY:	EMR	DATE DWN:	11/15/16
DECIMALS: $X = \pm .000$	APR BY:		DATE APR:	
$XX = \pm .020$	APR BY:		DATE APR:	
$XXX = \pm .010$	APR BY:		DATE APR:	
ANGLES: $= \pm 1^{\circ}0'$	APR BY:		DATE APR:	
CABINET SQUARENESS: $= \pm .0625$	APR BY:		DATE APR:	

CONFIDENTIAL:
 ALL DESIGN RIGHTS RESERVED
 THE INFORMATION, DATA, DESIGN, AND DRAWINGS EMBODIED IN THIS DOCUMENT AND ALL REPRODUCTIONS THEREOF ARE THE EXCLUSIVE PROPERTY OF DIVERSIFIED WOODCRAFTS, INC.

THESE DOCUMENTS ARE SUPPLIED WITH THE UNDERSTANDING THAT THEY WILL NOT BE DISCLOSED TO THIRD PARTIES WITHOUT WRITTEN CONSENT OF DIVERSIFIED WOODCRAFTS, INC. ANY REPRODUCTION IN PART OR WHOLE WITHOUT WRITTEN CONSENT IS SUBJECT TO LEGAL ACTION.

STEP 3:

- PLACE MOBILE CABINET IN DESIRED LOCATION.

	300 South Krueger Street Suring, WI 54174 diversifiedwoodcrafts.com	
	TITLE: ROBOT TOTE TRAY CABINET ASSEMBLY INSTRUCTIONS	
DRAWING NUMBER:	SCALE:	REVISION:
VXT & XT-3624, VXT & XT-5024	NTS	5 OF 5 REV A