

# MOBILE HAND WASH STATION

WSP1-30, WSP1-36, WSP2-30 & WSP2-36 SERIES (OAK OR MAPLE)  
 ASSEMBLY INSTRUCTIONS

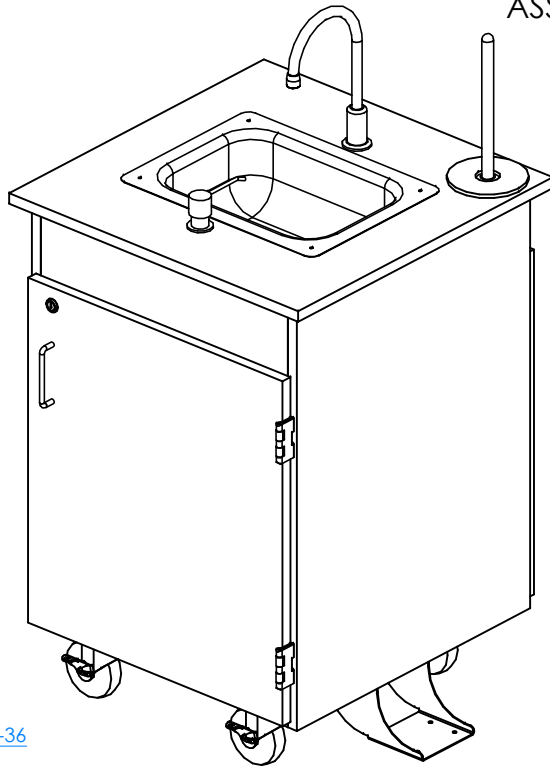

WSP1-36

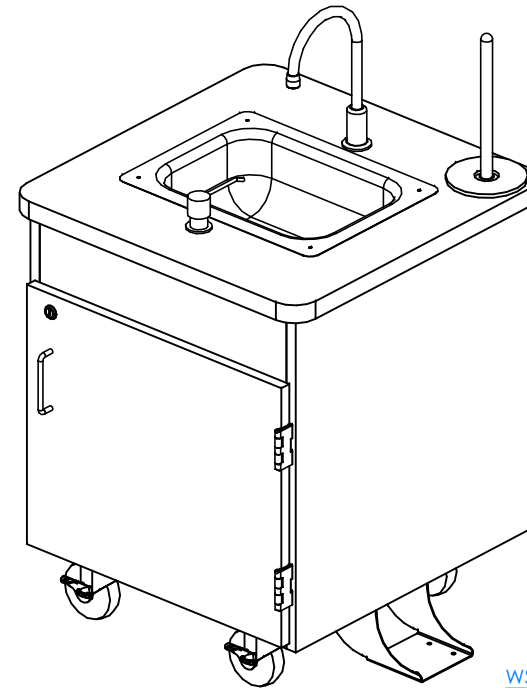

WSP1-30

**NOTE:**

1. MODEL VIEWS MAY NOT REPRESENT EXACT MODEL PURCHASED

ALL DIMENSIONS ARE IN INCHES UNLESS NOTED OTHERWISE	DWN BY:	EMR	DATE DWN:	4/15/21
DECIMALS: X = ± .000	APR BY:		DATE APR:	
XX = ± .020	APR BY:		DATE APR:	
XXX = ± .010	APR BY:		DATE APR:	
ANGLES: = ± 1°0'	APR BY:		DATE APR:	
CABINET SQUARENESS: = ± .0625	APR BY:		DATE APR:	

CONFIDENTIAL:  
 ALL DESIGN RIGHTS RESERVED  
 THE INFORMATION, DATA, DESIGN, AND DRAWINGS EMBODIED IN THIS DOCUMENT AND ALL REPRODUCTIONS THEREOF ARE THE EXCLUSIVE PROPERTY OF DIVERSIFIED WOODCRAFTS, INC.

THESE DOCUMENTS ARE SUPPLIED WITH THE UNDERSTANDING THAT THEY WILL NOT BE DISCLOSED TO THIRD PARTIES WITHOUT WRITTEN CONSENT OF DIVERSIFIED WOODCRAFTS, INC. ANY REPRODUCTION IN PART OR WHOLE WITHOUT WRITTEN CONSENT IS SUBJECT TO LEGAL ACTION.



300 South Krueger Street  
 Suring, WI 54174  
 diversifiedwoodcrafts.com

TITLE:  
 MOBILE HAND WASH STATION W/ FOOT PUMP  
 ASSEMBLY INSTRUCTIONS

REV.	DESCRIPTION	DATE	NAME	ECN No.
A	CREATED DRAWING	4/15/21	EMR	N/A
	REVISION LEVEL			

DRAWING NUMBER:	SCALE:	SHEET:	REVISION:
WSP1-30/36 & WSP2-30/36 SERIES	NTS	1 OF 6	REV A

ASSEMBLY COMPONENTS			
ITEMS INCLUDED	PART #	PART DESCRIPTION	QTY
FRESH AND WASTE WATER CONTAINER	VARIES	WATER JUG, (EITHER 2.50 OR 5 GAL) RECTANGULAR	4
UPRIGHTS	256327	ROD, UPRIGHT 3/4 DIA.X10 L	VARIES
ROD SOCKET ASSEMBLY	206505	ROD SOCKET ASSY, SOCKET, WASHER, NUT	VARIES
SPACER	256736	SPACER, HDPE, 5.13 DIA, BLK	VARIES

**NOTE:**

1. COMPONENTS VARY WITH STYLE OF STATION PURCHASED.
  - 1.1. WSP1-30 & WSP1-36 WILL RECEIVE (1) ROD SOCKET ASSEMBLY, UPRIGHT, AND SPACER.
  - 1.2. WSP2-30 & WSP2-36 WILL RECEIVE (2) ROD SOCKET ASSEMBLIES, UPRIGHTS, AND SPACERS.

ALL DIMENSIONS ARE IN INCHES UNLESS NOTED OTHERWISE DECIMALS: X = ± .000 XX = ± .020 XXX = ± .010 ANGLES: = ± 1° CABINET SQUARENESS: = ± .0625	DWN BY: EMR	DATE DWN: 4/15/21
	APR BY:	DATE APR:
	APR BY:	DATE APR:

CONFIDENTIAL:  
ALL DESIGN RIGHTS RESERVED  
THE INFORMATION, DATA, DESIGN, AND DRAWINGS EMBODIED IN THIS DOCUMENT AND ALL REPRODUCTIONS THEREOF ARE THE EXCLUSIVE PROPERTY OF DIVERSIFIED WOODCRAFTS, INC.

THESE DOCUMENTS ARE SUPPLIED WITH THE UNDERSTANDING THAT THEY WILL NOT BE DISCLOSED TO THIRD PARTIES WITHOUT WRITTEN CONSENT OF DIVERSIFIED WOODCRAFTS, INC. ANY REPRODUCTION IN PART OR WHOLE WITHOUT WRITTEN CONSENT IS SUBJECT TO LEGAL ACTION.

A	CREATED DRAWING	4/15/21	EMR	N/A
REV.	DESCRIPTION	DATE	NAME	ECN No.
	REVISION LEVEL			



300 South Krueger Street  
Suring, WI 54174  
diversifiedwoodcrafts.com

TITLE:  
MOBILE HAND WASH STATION W/ FOOT PUMP TOOLS AND ASSEMBLY COMPONENTS

DRAWING NUMBER: WSP1-30/36 & WSP2-30/36 SERIES	SCALE: NTS	SHEET: 2 OF 6	REVISION: REV A
---	---------------	------------------	--------------------

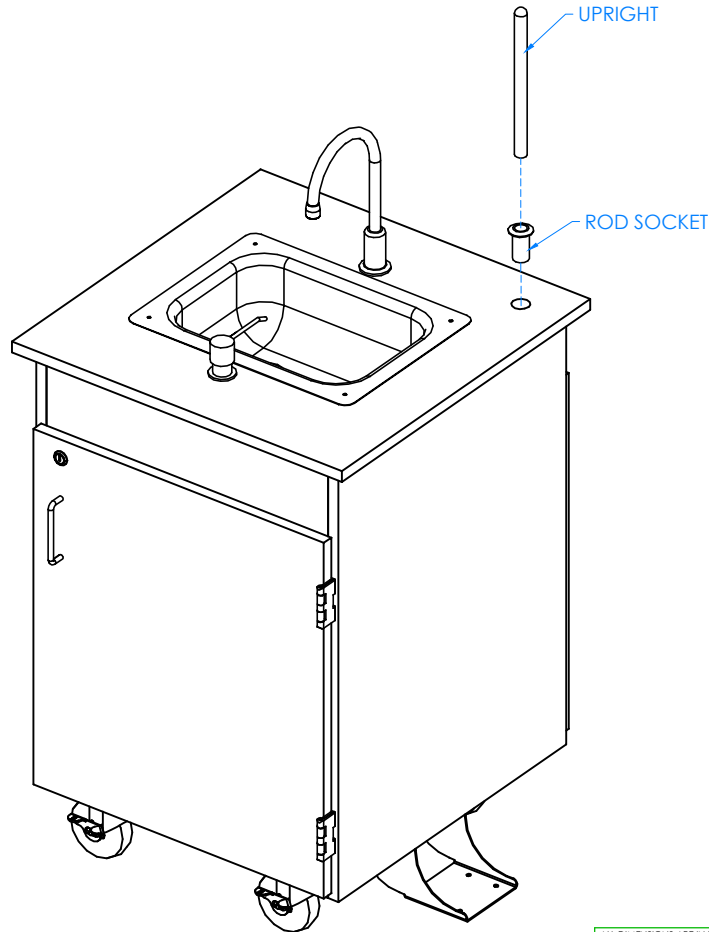

STEP 1:

- INSERT ROD SOCKET INTO PRE-DRILLED HOLE ON TOP.
- INSERT UPRIGHT INTO ROD SOCKET.

NOTE:

1. BE SURE CASTERS ARE LOCKED WHEN IN USE AND WHEN FILLING AND EXCHANGING WATER JUGS.

ALL DIMENSIONS ARE IN INCHES UNLESS NOTED OTHERWISE	DWN BY:	EMR	DATE DWN:	4/15/21
DECIMALS: $X = \pm .000$	APR BY:		DATE APR:	
$XX = \pm .020$	APR BY:		DATE APR:	
$XXX = \pm .010$	APR BY:		DATE APR:	
ANGLES: $= \pm 1^{\circ}0'$	APR BY:		DATE APR:	
CABINET SQUARENESS: $= \pm .0625$	APR BY:		DATE APR:	

CONFIDENTIAL:  
 ALL DESIGN RIGHTS RESERVED  
 THE INFORMATION, DATA, DESIGN, AND DRAWINGS EMBODIED IN THIS DOCUMENT AND ALL REPRODUCTIONS THEREOF ARE THE EXCLUSIVE PROPERTY OF DIVERSIFIED WOODCRAFTS, INC.

THESE DOCUMENTS ARE SUPPLIED WITH THE UNDERSTANDING THAT THEY WILL NOT BE DISCLOSED TO THIRD PARTIES WITHOUT WRITTEN CONSENT OF DIVERSIFIED WOODCRAFTS, INC. ANY REPRODUCTION IN PART OR WHOLE WITHOUT WRITTEN CONSENT IS SUBJECT TO LEGAL ACTION.



300 South Krueger Street  
 Suring, WI 54174  
 diversifiedwoodcrafts.com

TITLE:  
**MOBILE HAND WASH STATION W/ FOOT PUMP ASSEMBLY INSTRUCTIONS**

REV.	DESCRIPTION	DATE	NAME	ECN No.
A	CREATED DRAWING	4/15/21	EMR	N/A
REVISION LEVEL				

DRAWING NUMBER:	SCALE:	SHEET:	REVISION:
WSP1-30/36 & WSP2-30/36 SERIES	NTS	3 OF 6	REV A

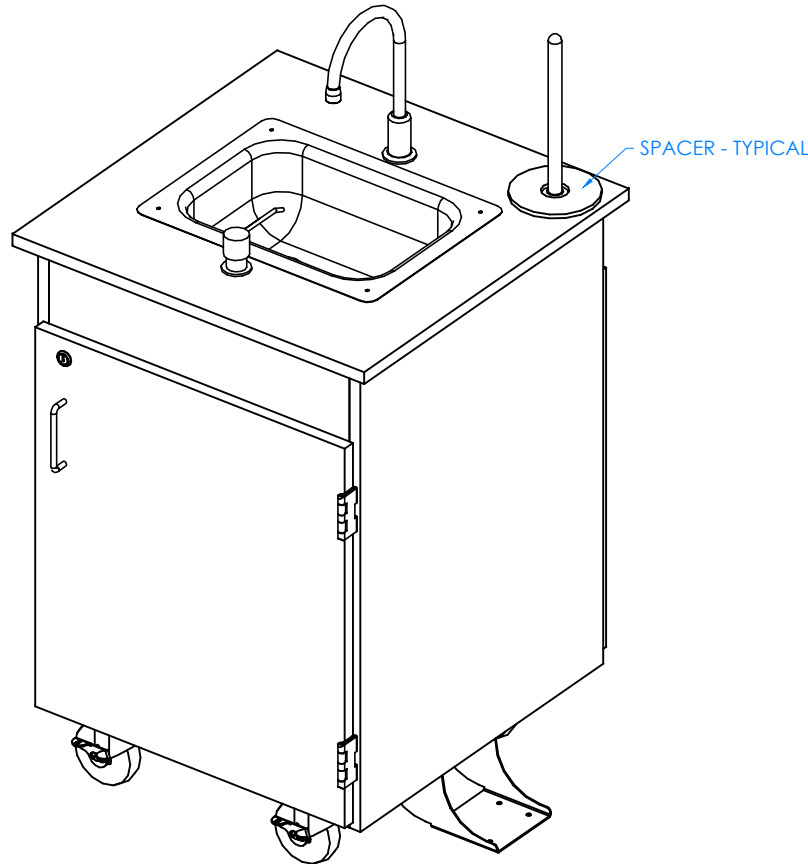

STEP 2:

- PLACE SPACER ON UPRIGHT.

NOTE:

1. BE SURE CASTERS ARE LOCKED WHEN IN USE AND WHEN FILLING AND EXCHANGING WATER JUGS.

ALL DIMENSIONS ARE IN INCHES UNLESS NOTED OTHERWISE	DWN BY:	EMR	DATE DWN:	4/15/21
DECIMALS: X = ± .000	APR BY:		DATE APR:	
XX = ± .020	APR BY:		DATE APR:	
XXX = ± .010	APR BY:		DATE APR:	
ANGLES: = ± 1°0'	APR BY:		DATE APR:	
CABINET SQUARENESS: = ± .0625	APR BY:		DATE APR:	

CONFIDENTIAL:  
 ALL DESIGN RIGHTS RESERVED  
 THE INFORMATION, DATA, DESIGN, AND DRAWINGS EMBODIED IN THIS DOCUMENT AND ALL REPRODUCTIONS THEREOF ARE THE EXCLUSIVE PROPERTY OF DIVERSIFIED WOODCRAFTS, INC.

THESE DOCUMENTS ARE SUPPLIED WITH THE UNDERSTANDING THAT THEY WILL NOT BE DISCLOSED TO THIRD PARTIES WITHOUT WRITTEN CONSENT OF DIVERSIFIED WOODCRAFTS, INC. ANY REPRODUCTION IN PART OR WHOLE WITHOUT WRITTEN CONSENT IS SUBJECT TO LEGAL ACTION.



300 South Krueger Street  
 Suring, WI 54174  
 diversifiedwoodcrafts.com

TITLE:  
 MOBILE HAND WASH STATION W/ FOOT PUMP  
 ASSEMBLY INSTRUCTIONS

REV.	DESCRIPTION	DATE	NAME	ECN No.
A	CREATED DRAWING	4/15/21	EMR	N/A
REVISION LEVEL				

DRAWING NUMBER:	SCALE:	SHEET:	REVISION:
WSP1-30/36 & WSP2-30/36 SERIES	NTS	4 OF 6	REV A



FLEX SINK DRAIN -  
ADJUSTMENTS MAY BE  
REQUIRED!

QUICK -DISCONNECT TUBE

STEP 3:

- FILL UP FRESH WATER JUGS WITH WATER.
- PLACE FRESH AND WASTE WATER JUGS INTO CABINET.
- HOOK UP QUICK-DISCONNECT TUBING TO ONE FRESH WATER JUG.
- PLACE FLEX SINK DRAIN INTO WASTE WATER JUG.

**\*\*NOTE\*\***  
MAKE SURE ONE FRESH JUG AND ONE WASTE  
JUG IS ON THE SAME SIDE BEHIND DOOR!  
THIS ENSURES EASY ACCESS WHEN REMOVING  
AND REPLACING JUGS.

NOTE:

1. BE SURE CASTERS ARE LOCKED WHEN IN USE AND WHEN FILLING AND EXCHANGING WATER JUGS.

ALL DIMENSIONS ARE IN INCHES UNLESS NOTED OTHERWISE	DWN BY:	EMR	DATE DWN:	4/15/21
DECIMALS: .X = ± .000 .XX = ± .020 .XXX = ± .010	APR BY:		DATE APR:	
ANGLES: = ± 1°	APR BY:		DATE APR:	
CABINET SQUARENESS: = ± .0625				

CONFIDENTIAL:  
ALL DESIGN RIGHTS RESERVED  
THE INFORMATION, DATA, DESIGN, AND DRAWINGS EMBODIED IN THIS DOCUMENT AND ALL REPRODUCTIONS THEREOF ARE THE EXCLUSIVE PROPERTY OF DIVERSIFIED WOODCRAFTS, INC.

THESE DOCUMENTS ARE SUPPLIED WITH THE UNDERSTANDING THAT THEY WILL NOT BE DISCLOSED TO THIRD PARTIES WITHOUT WRITTEN CONSENT OF DIVERSIFIED WOODCRAFTS, INC. ANY REPRODUCTION IN PART OR WHOLE WITHOUT WRITTEN CONSENT IS SUBJECT TO LEGAL ACTION.



300 South Krueger Street  
Suring, WI 54174  
diversifiedwoodcrafts.com

TITLE:  
MOBILE HAND WASH STATION W/ FOOT PUMP  
ASSEMBLY INSTRUCTIONS

A	CREATED DRAWING	4/15/21	EMR	N/A
REV.	DESCRIPTION	DATE	NAME	ECN No.
	REVISION LEVEL			

DRAWING NUMBER:	SCALE:	SHEET:	REVISION:
WSP1-30/36 & WSP2-30/36 SERIES	NTS	5 OF 6	REV A

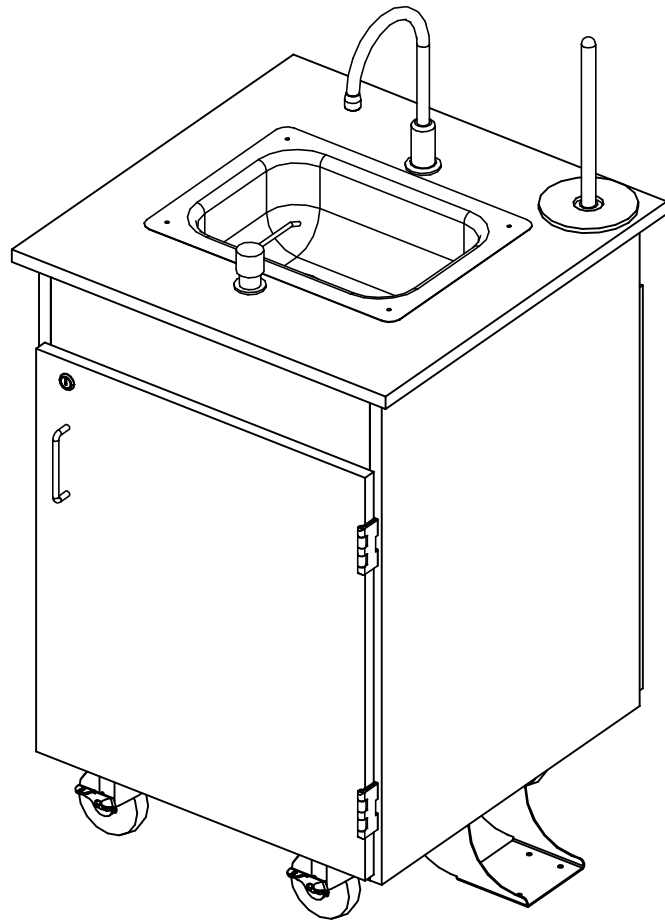

STEP 4:

- ONCE CABINET IS READY TO USE, SET IN DESIRED LOCATION.
- PLACE PAPER TOWELING ON UPRIGHTS (NOT PROVIDED).

NOTE:

1. BE SURE CASTERS ARE LOCKED WHEN IN USE AND WHEN FILLING AND EXCHANGING WATER JUGS.

COMPLETE UNIT SHOWN

ALL DIMENSIONS ARE IN INCHES UNLESS NOTED OTHERWISE	DWN BY:	EMR	DATE DWN:	4/15/21
DECIMALS: $\times = \pm .000$	APR BY:		DATE APR:	
$_{XX} = \pm .020$	APR BY:		DATE APR:	
$_{XXX} = \pm .010$	APR BY:		DATE APR:	
ANGLES: $= \pm 1^{\circ}0'$	APR BY:		DATE APR:	
CABINET SQUARENESS: $= \pm .0625$	APR BY:		DATE APR:	

CONFIDENTIAL:  
 ALL DESIGN RIGHTS RESERVED  
 THE INFORMATION, DATA, DESIGN, AND DRAWINGS EMBODIED IN THIS DOCUMENT AND ALL REPRODUCTIONS THEREOF ARE THE EXCLUSIVE PROPERTY OF DIVERSIFIED WOODCRAFTS, INC.

THESE DOCUMENTS ARE SUPPLIED WITH THE UNDERSTANDING THAT THEY WILL NOT BE DISCLOSED TO THIRD PARTIES WITHOUT WRITTEN CONSENT OF DIVERSIFIED WOODCRAFTS, INC. ANY REPRODUCTION IN PART OR WHOLE WITHOUT WRITTEN CONSENT IS SUBJECT TO LEGAL ACTION.



300 South Krueger Street  
 Suring, WI 54174  
 diversifiedwoodcrafts.com

TITLE:  
 MOBILE HAND WASH STATION W/ FOOT PUMP  
 ASSEMBLY INSTRUCTIONS

REV.	DESCRIPTION	DATE	EMR	NAME	ECN No.
A	CREATED DRAWING	4/15/21	EMR	N/A	
REVISION LEVEL					

DRAWING NUMBER:	SCALE:	SHEET:	REVISION:
WSP1-30/36 & WSP2-30/36 SERIES	NTS	6 OF 6	REV A